

- Tentative Specification
- Preliminary Specification
- Approval Specification

**MODEL NO.: V500HK1**  
**SUFFIX: LD1**

<b>Customer:</b>	
<b>APPROVED BY</b>	<b>SIGNATURE</b>
Name / Title _____	_____
<b>Note</b>	
Please return 1 copy for your confirmation with your signature and comments.	

Approved By	Checked By	Prepared By
Chao-Chun Chung	Ken Wu	HT Hung

## CONTENTS

1. GENERAL DESCRIPTION .....	5
1.1 OVERVIEW .....	5
1.2 FEATURES .....	5
1.3 APPLICATION .....	5
1.4 GENERAL SPECIFICATIONS .....	5
1.5 MECHANICAL SPECIFICATIONS .....	6
2. ABSOLUTE MAXIMUM RATINGS .....	7
2.1 ABSOLUTE RATINGS OF ENVIRONMENT .....	7
2.2 PACKAGE STORAGE .....	8
2.3 ELECTRICAL ABSOLUTE RATINGS .....	8
2.3.1 TFT LCD MODULE .....	8
2.3.2 BACKLIGHT UNIT .....	8
3. ELECTRICAL CHARACTERISTICS .....	9
3.1 TFT LCD MODULE .....	9
3.2 BACKLIGHT UNIT .....	12
3.2.1 LED LIGHT BAR CHARACTERISTICS (Ta= 25 ±2 °C) .....	12
4. BLOCK DIAGRAM OF INTERFACE .....	13
4.1 TFT LCD MODULE .....	13
5. INPUT TERMINAL PIN ASSIGNMENT .....	14
5.1 TFT LCD INTERFACE .....	14
5.2 BLU UNIT .....	17
5.3 BLOCK DIAGRAM OF INTERFACE .....	18
5.4 LVDS INTERFACE .....	19
5.5 COLOR DATA INPUT ASSIGNMENT .....	21
6. INTERFACE TIMING .....	22
6.1 INPUT SIGNAL TIMING SPECIFICATIONS .....	22
6.2 POWER ON/OFF SEQUENCE .....	25
7. OPTICAL CHARACTERISTICS .....	26
7.1 TEST CONDITIONS .....	26
7.2 OPTICAL SPECIFICATIONS .....	27

8 PRECAUTIONS.....	32
8.1 ASSEMBLY AND HANDLING PRECAUTIONS .....	32
8.2 SAFETY PRECAUTIONS .....	32
8.3 SAFETY REVIEW .....	32
8.3.1 SAFETY STANDARDS .....	32
9. DEFINITION OF LABELS.....	33
9.1 CMI MODULE LABEL .....	33
10. PACKAGING.....	34
10.1 PACKAGING SPECIFICATIONS .....	34
10.2 PACKAGING METHOD.....	34
11. MECHANICAL CHARACTERISTIC.....	36

## REVISION HISTORY

Version	Date	Page(New)	Section	Description
Ver. 0.0	Oct. 11,11	All	All	The Tentative specification was first issued.
Ver. 1.0	Jan.19, 12	All	All	The Preliminary specification was first issued.
Ver. 2.0	Feb.27,12	All	All	The Approval Specification was first issued.

## 1. GENERAL DESCRIPTION

### 1.1 OVERVIEW

V500HK1-LD1 is a 50" TFT Liquid Crystal Display module with Direct LED Backlight unit and 2ch-LVDS interface. This module supports 1920 x 1080 Full HDTV format and can display 16.7M colors (8-bit). The Converter module for backlight isn't built-in.

### 1.2 FEATURES

- High brightness (350 nits)
- High contrast ratio (5000:1)
- High color saturation (NTSC 72%)
- Full HDTV (1920 x 1080 pixels) resolution, true HDTV format
- DE (Data Enable) only mode
- LVDS (Low Voltage Differential Signaling) interface
- Optimized response time for 60 Hz frame rate
- Ultra wide viewing angle : Super MVA technology
- RoHs compliance

### 1.3 APPLICATION

- Standard Living Room TVs
- Public Display Application
- Home Theater Application
- MFM Application

### 1.4 GENERAL SPECIFICATIONS

Item	Specification	Unit	Note
Active Area	1095.84(H) x (V) 616.41 (50" diagonal)	mm	(1)
Bezel Opening Area	1102.84(H) x 623.41(V)	mm	
Driver Element	a-si TFT active matrix	-	-
Pixel Number	1920 x R.G.B. x 1080	pixel	-
Pixel Pitch(Sub Pixel)	0.1903(H) x 0.5708(V)	mm	-
Pixel Arrangement	RGB vertical stripe	-	-
Display Colors	16.7M	color	-
Display Operation Mode	Transmissive mode / Normally Black	-	-
Surface Treatment	Anti-Glare coating (Haze 3.5%) Hardness 3H	-	(3)

Note (1) Please refer to the attached drawings in chapter 9 for more information about the front and back outlines.

Note (2) Please refer sec 3.1 and 3.2 for more information of Power consumption

Note (3) The spec. of the surface treatment is temporarily for this phase. CMI reserves the rights to change this feature.

## 1.5 MECHANICAL SPECIFICATIONS

Item		Min.	Typ.	Max.	Unit	Note
Module Size	Horizontal (H)	1141.54	1142.84	1144.14	mm	(1)
	Vertical (V)	662.11	663.41	664.71	mm	(1)
	Depth (D)		NA		mm	(2)
	Depth (D)	50.5	51.8	53.1	mm	(3)
Weight			12480		g	-

Note (1) Please refer to the attached drawings for more information of front and back outline dimensions.

Note (2) Module Depth is between bezel to T-CON cover.

Note (3) Module Depth is between bezel to rear.

## 2. ABSOLUTE MAXIMUM RATINGS

### 2.1 ABSOLUTE RATINGS OF ENVIRONMENT

Item	Symbol	Value		Unit	Note
		Min.	Max.		
Storage Temperature	TST	-20	+60	°C	(1)
Operating Ambient Temperature	TOP	0	50	°C	(1), (2)
Shock (Non-Operating)	S <sub>NOP</sub>	-	35	G	(3), (5)
Vibration (Non-Operating)	VNOP	-	1.0	G	(4), (5)

Note (1) Temperature and relative humidity range is shown in the figure below.

(a) 90 %RH Max. ( $T_a \leq 40$  °C).

(b) Wet-bulb temperature should be 39 °C Max. ( $T_a > 40$  °C).

(c) No condensation.

Note (2) The maximum operating temperature is based on the test condition that the surface temperature of display area is less than or equal to 65 °C with LCD module alone in a temperature controlled chamber. Thermal management should be considered in final product design to prevent the surface temperature of display area from being over 65 °C. The range of operating temperature may degrade in case of improper thermal management in final product design.

Note (3) 11 ms, half sine wave, 1 time for  $\pm X$ ,  $\pm Y$ ,  $\pm Z$ .

Note (4) 10 ~ 200 Hz, 30 min, 1 time each X, Y, Z.

Note (5) At testing Vibration and Shock, the fixture in holding the module has to be hard and rigid enough so that the module would not be twisted or bent by the fixture.

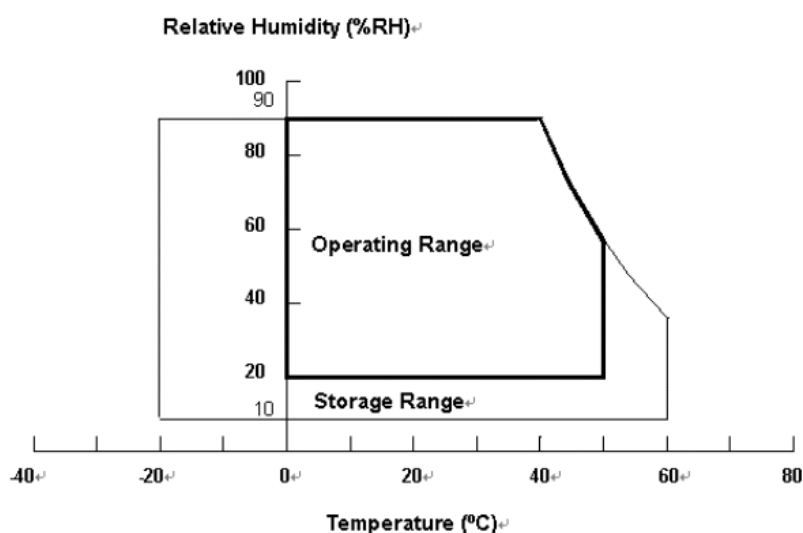

## 2.2 PACKAGE STORAGE

When storing modules as spares for a long time, the following precaution is necessary.

- (a) Do not leave the module in high temperature, and high humidity for a long time, It is highly recommended to store the module with temperature from 0 to 35 °C at normal humidity without condensation.
- (b) The module shall be stored in dark place. Do not store the TFT-LCD module in direct sunlight or fluorescent light.

## 2.3 ELECTRICAL ABSOLUTE RATINGS

### 2.3.1 TFT LCD MODULE

Item	Symbol	Value		Unit	Note
		Min.	Max.		
Power Supply Voltage	VCC	-0.3	13.5	V	(1)
Logic Input Voltage	VIN	-0.3	3.6	V	

### 2.3.2 BACKLIGHT UNIT

Item	Symbol	Value		Unit	Note
		Min.	Max.		
Light bar Voltage	VW	—	193	V <sub>DC</sub>	(1)

Note (1) Permanent damage to the device may occur if maximum values are exceeded. Function operation should be restricted to the conditions described under Normal Operating Conditions



## 3. ELECTRICAL CHARACTERISTICS

### 3.1 TFT LCD MODULE

(Ta = 25 ± 2 °C)

Parameter		Symbol	Value			Unit	Note
			Min.	Typ.	Max.		
Power Supply Voltage		V <sub>CC</sub>	10.8	12	13.2	V	(1)
Rush Current		I <sub>RUSH</sub>	—	—	3.4	A	(2)
Power consumption	White Pattern	—	—	4.4	4.8	W	(3)
	Horizontal Stripe	—	—	8.9	10.3	W	
	Black Pattern	—	—	4.4	4.8	W	
Power Supply Current	White Pattern	—	—	0.37	0.44	A	
	Horizontal Stripe	—	—	0.74	0.91	A	
	Black Pattern	—	—	0.37	0.44	A	
LVDS interface	Differential Input High Threshold Voltage	V <sub>LVTH</sub>	+100	—	—	mV	(4)
	Differential Input Low Threshold Voltage	V <sub>LVTL</sub>	—	—	-100	mV	
	Common Input Voltage	V <sub>CM</sub>	1.0	1.2	1.4	V	
	Differential input voltage (single-end)	V <sub>ID</sub>	200	—	600	mV	
	Terminating Resistor	R <sub>T</sub>	—	100	—	ohm	
CMIS interface	Input High Threshold Voltage	V <sub>IH</sub>	2.7	—	3.3	V	
	Input Low Threshold Voltage	V <sub>IL</sub>	0	—	0.7	V	

Note (1) The module should be always operated within the above ranges.

Note (2) Measurement condition:

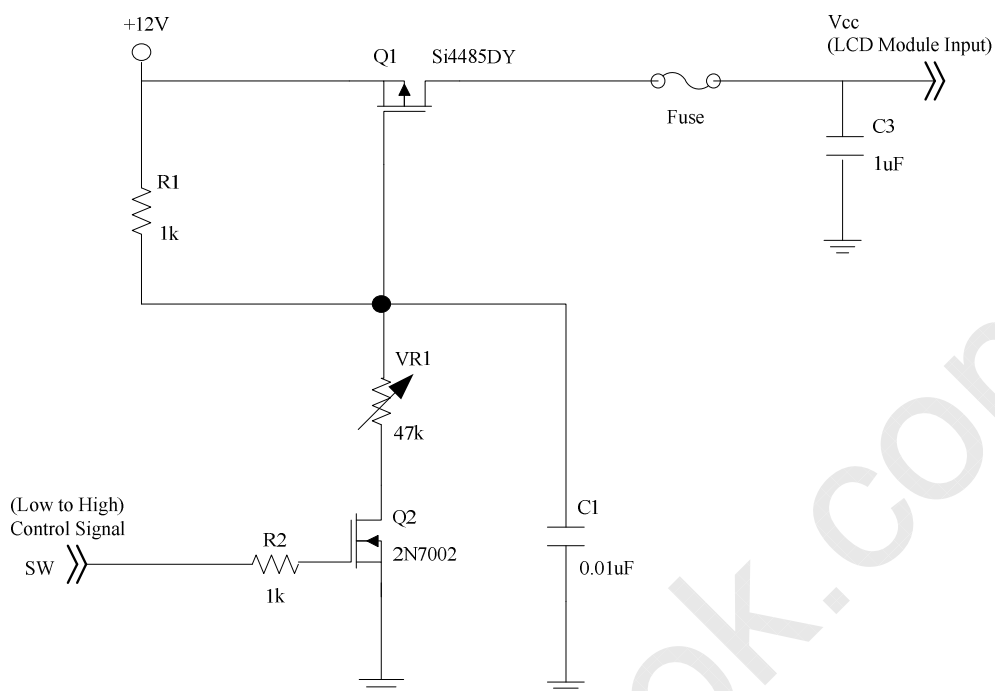

**Vcc rising time is 470us**

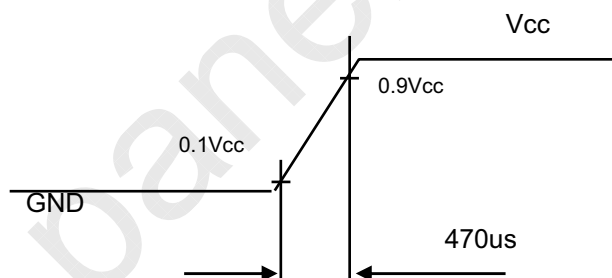

Note (3) The specified power supply current is under the conditions at  $V_{CC} = 12\text{ V}$ ,  $T_a = 25 \pm 2\text{ }^\circ\text{C}$ ,  $f_v = 60\text{ Hz}$ , whereas a power dissipation check pattern below is displayed.

a. White Pattern

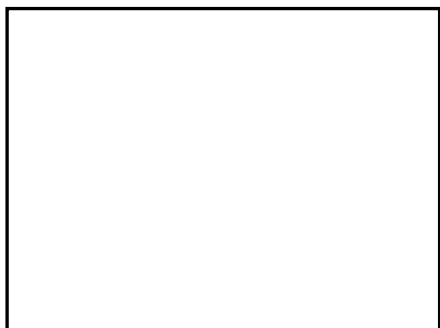

Active Area

b. Black Pattern



Active Area

c. Horizontal Pattern

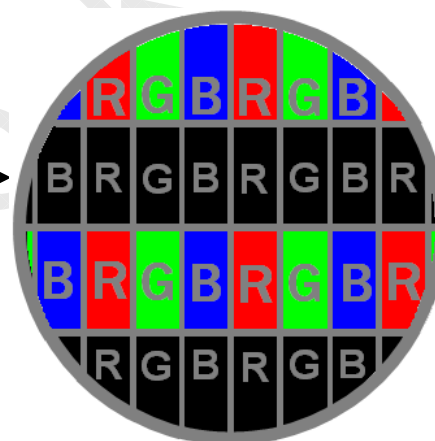
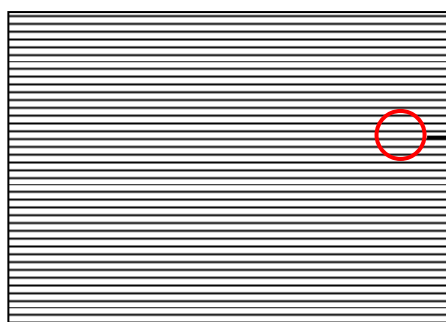

Note (4) The LVDS input characteristics are as follows :

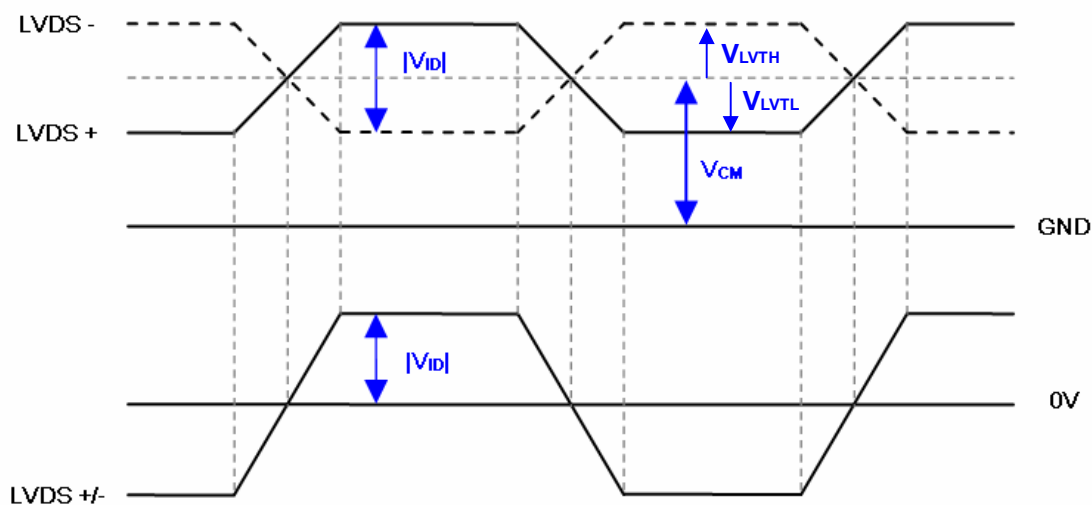

## 3.2 BACKLIGHT UNIT

### 3.2.1 LED LIGHT BAR CHARACTERISTICS (Ta= 25 ±2 °C)

Parameter	Symbol	Value			Unit	Note
		Min.	Typ.	Max.		
One Light Bar Current	$I_{L(2D)}$	159.8	170	180.2	mA	
One Light Bar Voltage	$V_{W(2D)}$	126.72	141.57	156.42	V <sub>DC</sub>	$I_L = 170\text{mA}$
	$\Delta V_W$	-	-	2.95	V	For 1 BLU $I_L = 170\text{mA}$
Power consumption	$P_{BL}$	90.49	96.27	102.04	W	only LEDs Duty=100% $I_{PIN} = 170\text{mA}$
Life time	-	30,000	-	-	Hrs	(1)

Note (1) The lifetime is defined as the time which luminance of the LED decays to 50% compared to the initial value, Operating condition: Continuous operating at Ta = 25±2°C,  $I_L = 170\text{mA}$ .

## 4. BLOCK DIAGRAM OF INTERFACE

### 4.1 TFT LCD MODULE

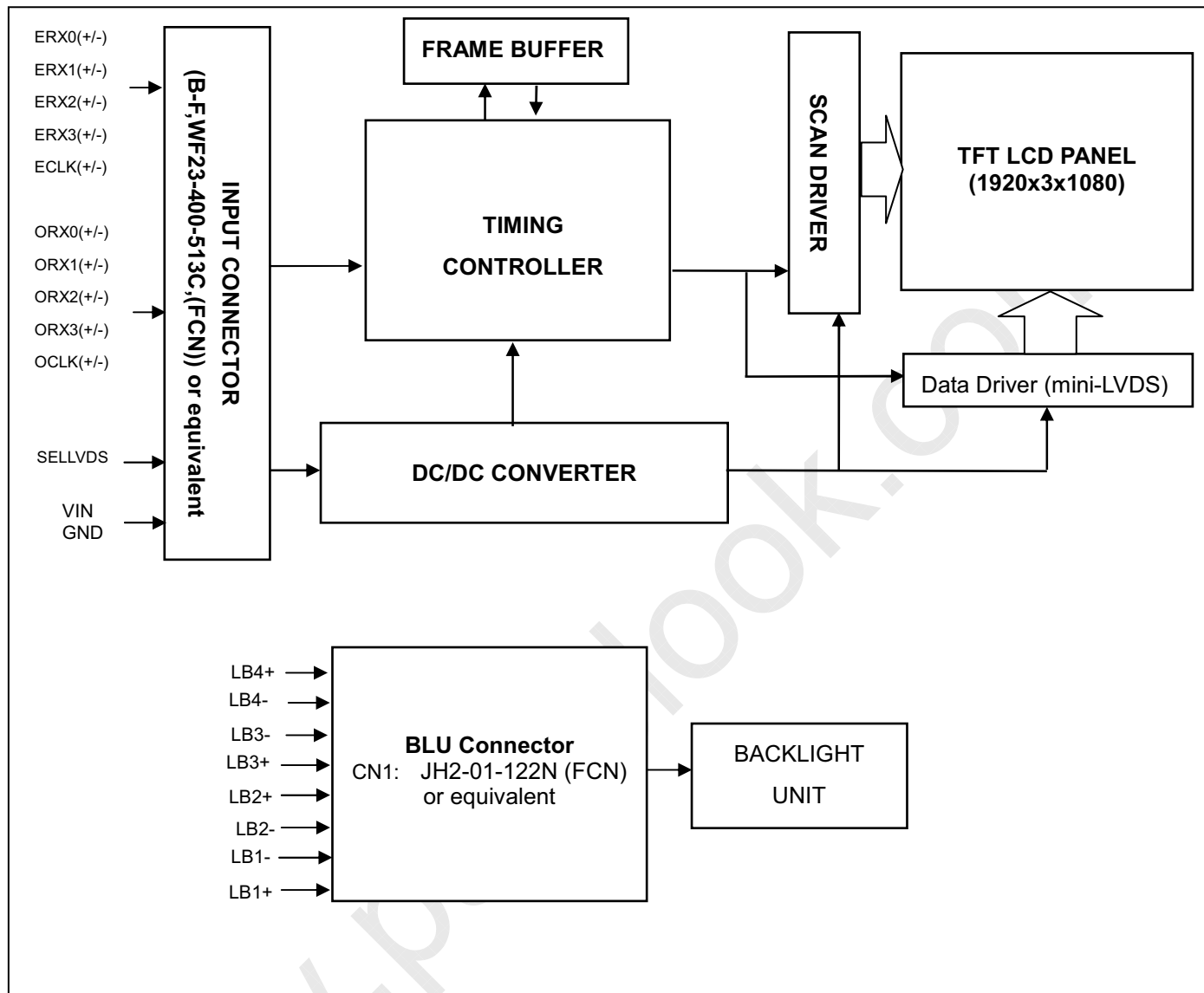

## 5. INPUT TERMINAL PIN ASSIGNMENT

### 5.1 TFT LCD INTERFACE

CNF1 Connector Part No.: B-F,WF23-400-513C,(全康-FCN) or equivalent.

Pin	Name	Description	Note
1	GND	Ground	
2	N.C.	No Connection	
3	N.C.	No Connection	
4	N.C.	No Connection	(2)
5	N.C.	No Connection	
6	N.C.	No Connection	
7	SELLVDS	LVDS data format Selection	(3)(4)
8	N.C.	No Connection	(2)
9	N.C.	No Connection	(2)
10	N.C.	No Connection	(2)
11	GND	Ground	
12	ERX0-	Even pixel Negative LVDS differential data input. Channel 0	
13	ERX0+	Even pixel Positive LVDS differential data input. Channel 0	
14	ERX1-	Even pixel Negative LVDS differential data input. Channel 1	
15	ERX1+	Even pixel Positive LVDS differential data input. Channel 1	(5)
16	ERX2-	Even pixel Negative LVDS differential data input. Channel 2	
17	ERX2+	Even pixel Positive LVDS differential data input. Channel 2	
18	GND	Ground	
19	ECLK-	Even pixel Negative LVDS differential clock input.	
20	ECLK+	Even pixel Positive LVDS differential clock input.	(5)
21	GND	Ground	
22	ERX3-	Even pixel Negative LVDS differential data input. Channel 3	
23	ERX3+	Even pixel Positive LVDS differential data input. Channel 3	(5)
24	N.C.	No Connection	
25	N.C.	No Connection	(2)
26	GND	Ground	
27	GND	Ground	
28	ORX0-	Odd pixel Negative LVDS differential data input. Channel 0	
29	ORX0+	Odd pixel Positive LVDS differential data input. Channel 0	
30	ORX1-	Odd pixel Negative LVDS differential data input. Channel 1	
31	ORX1+	Odd pixel Positive LVDS differential data input. Channel 1	(5)
32	ORX2-	Odd pixel Negative LVDS differential data input. Channel 2	
33	ORX2+	Odd pixel Positive LVDS differential data input. Channel 2	
34	GND	Ground	
35	OCLK-	Odd pixel Negative LVDS differential clock input	
36	OCLK+	Odd pixel Positive LVDS differential clock input	(5)
37	GND	Ground	
38	ORX3-	Odd pixel Negative LVDS differential data input. Channel 3	
39	ORX3+	Odd pixel Positive LVDS differential data input. Channel 3	(5)
40	N.C.	No Connection	
41	N.C.	No Connection	(2)
42	GND	Ground	
43	GND	Ground	
44	GND	Ground	
45	GND	Ground	
46	GND	Ground	
47	N.C.	No Connection	(2)
48	VCC	Power input (+12V)	
49	VCC	Power input (+12V)	
50	VCC	Power input (+12V)	
51	VCC	Power input (+12V)	

Note (1) LVDS connector pin order defined as follows

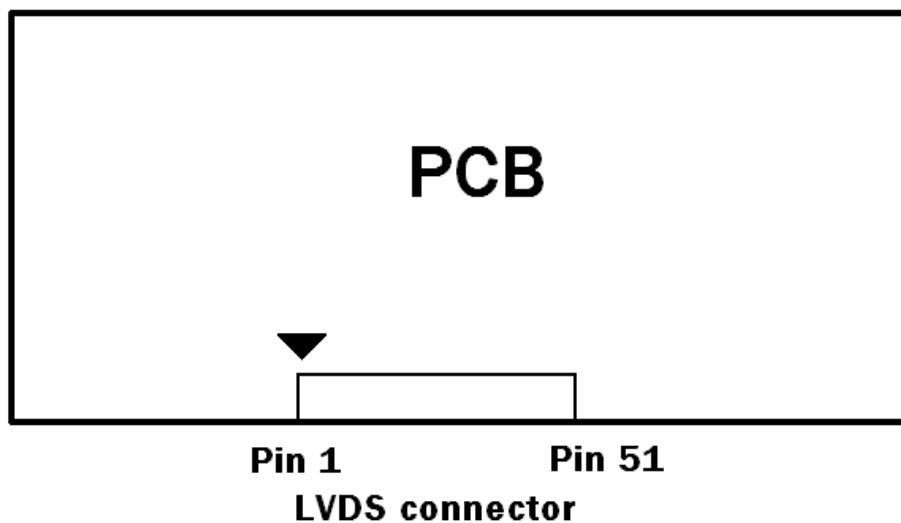

Note (2) Reserved for internal use. Please leave it open.

Note (3) LVDS format selection.

L= Connect to GND, H=Connect to +3.3V or Open

SELLVDS	Note
L	JEIDA Format
H or Open	VESA Format

Note (4) SELLVDS signal pin connected to the LCM side has the following diagram.

R1 in the system side should be less than 1K Ohm. ( $R1 < 1K \text{ Ohm}$ )

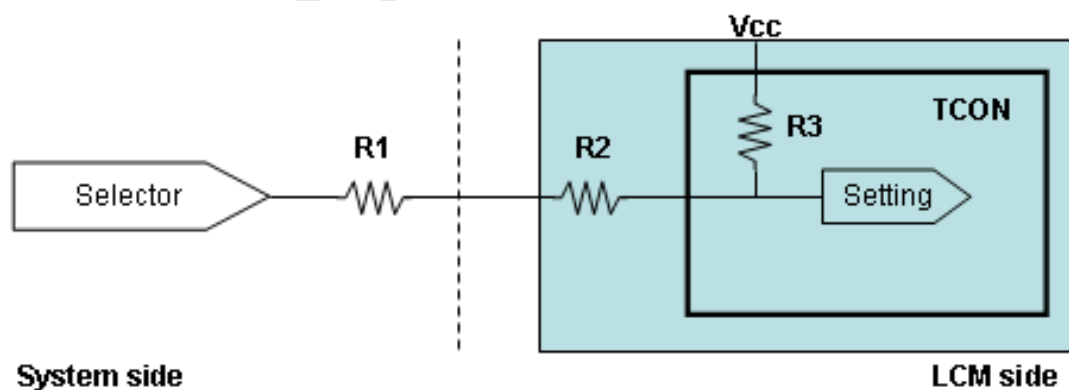

System side  
 $R1 < 1K$

Note (5) Two pixel data send into the module for every clock cycle. The first pixel of the frame is odd pixel and the second pixel is even pixel



**5.2 BLU UNIT**
**CN : W-B,JH2-01-122N(全康-FCN)or equivalent.**

Pin □	Symbol	Feature
1	LB4-	Negative of Light Bar 4
2	NC	No Connection
3	LB4+	Positive of Light Bar 4
4	LB3+	Positive of Light Bar 3
5	NC	No Connection
6	LB3-	Negative of Light Bar 3
7	LB2-	Negative of Light Bar 2
8	NC	No Connection
9	LB2+	Positive of Light Bar 2
10	LB1+	Positive of Light Bar 1
11	NC	No Connection
12	LB1-	Negative of Light Bar 1

## 5.3 BLOCK DIAGRAM OF INTERFACE

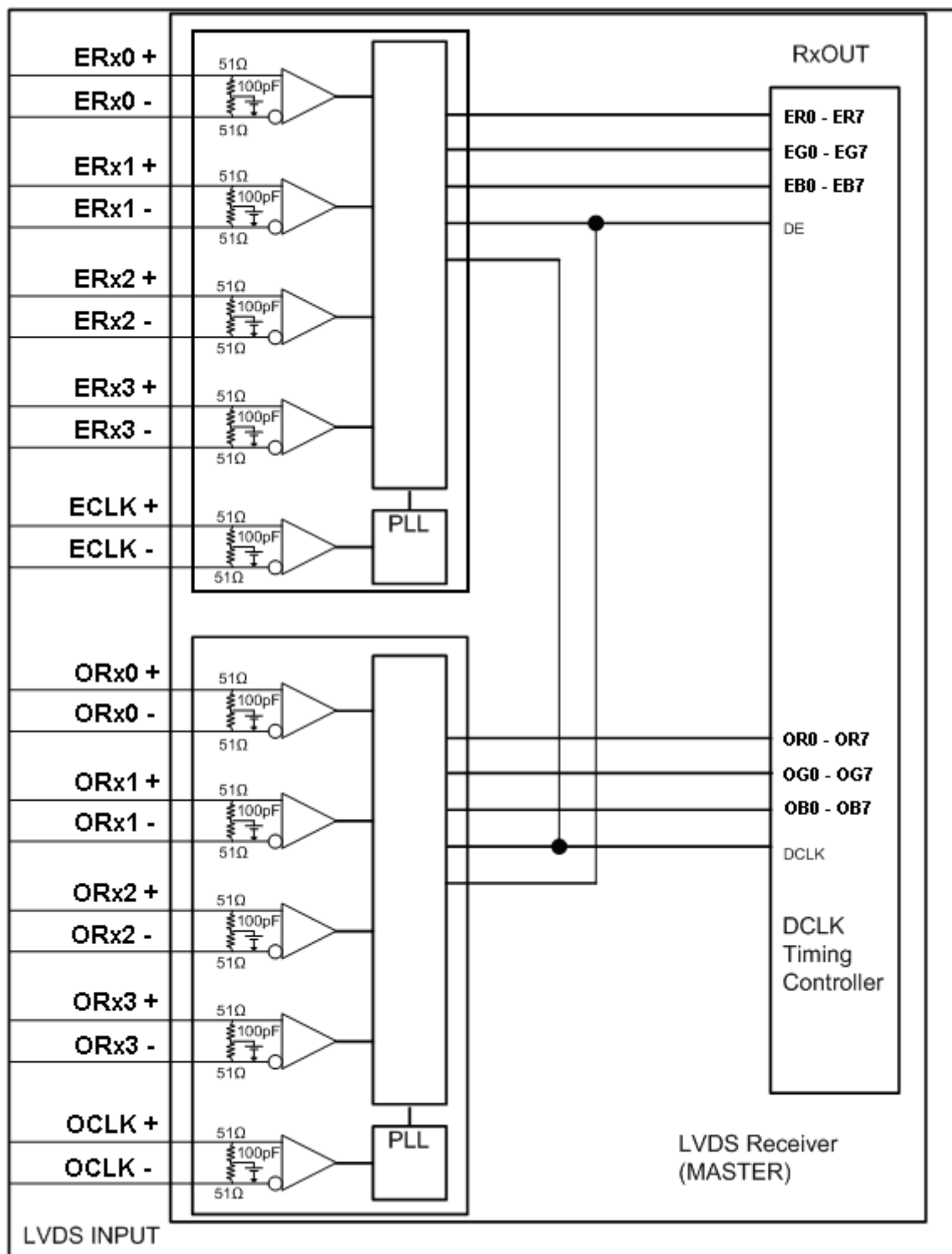

ER0~ER7	Even pixel R data	OR0~OR7	Odd pixel R data
EG0~EG7	Even pixel G data	OG0~OG7	Odd pixel G data
EB0~EB7	Even pixel B data	OB0~OB7	Odd pixel B data
		DE	Data enable signal
		DCLK	Data clock signal

Note (1) The system must have the transmitter to drive the module.

Note (2) LVDS cable impedance shall be 50 ohms per signal line or about 100 ohms per twist-pair line when it is used differentially.

Note (3) Two pixel data send into the module for every clock cycle. The first pixel of the frame is odd pixel and the second pixel is even pixel.

## 5.4 LVDS INTERFACE

VESA Format : SELLVDS = H or Open

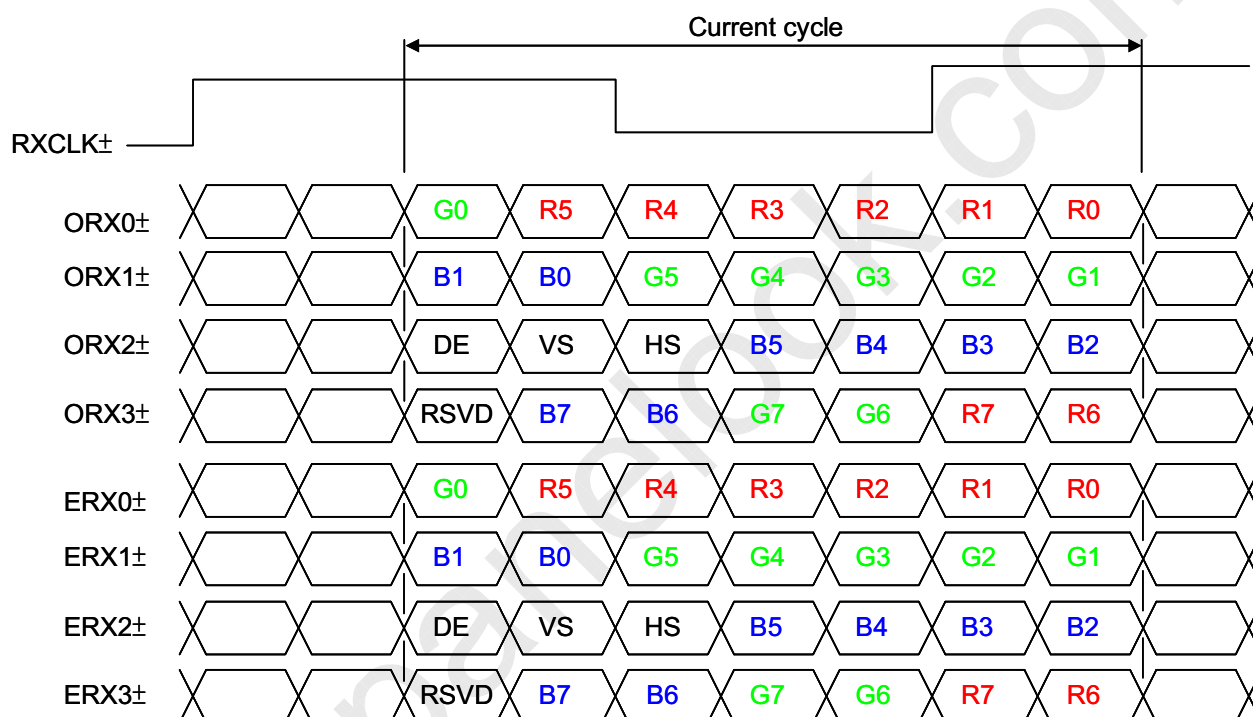

JEIDA Format : SELLVDS = L

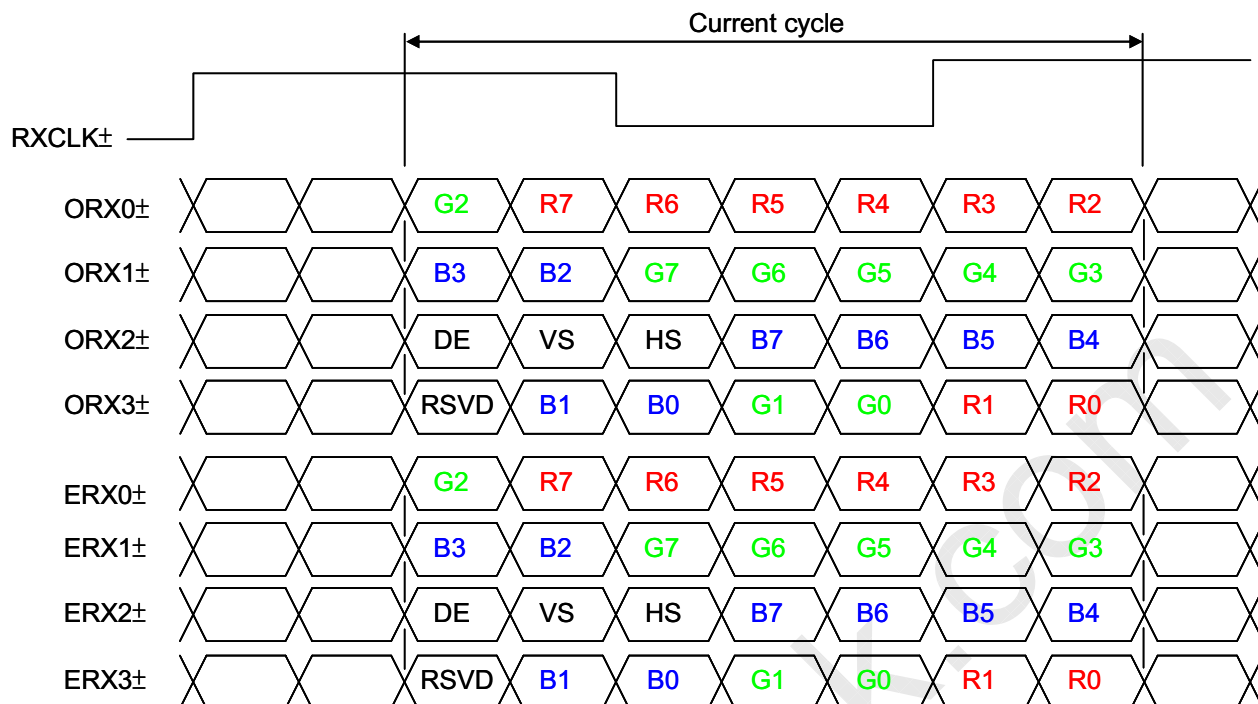

R0~R7: Pixel R Data (7; MSB, 0; LSB)

G0~G7: Pixel G Data (7; MSB, 0; LSB)

B0~B7: Pixel B Data (7; MSB, 0; LSB)

DE : Data enable signal

DCLK : Data clock signal

Notes: (1) RSVD (reserved) pins on the transmitter shall be "H" or "L".

## 5.5 COLOR DATA INPUT ASSIGNMENT

The brightness of each primary color (red, green and blue) is based on the 8-bit gray scale data input for the color. The higher the binary input, the brighter the color. The table below provides the assignment of the color versus data input.

Color		Data Signal																							
		Red								Green								Blue							
		R7	R6	R5	R4	R3	R2	R1	R0	G7	G6	G5	G4	G3	G2	G1	G0	B7	B6	B5	B4	B3	B2	B1	B0
Basic Colors	Black	0	0	0	0	0	0	0	0	0	0	0	0	0	0	0	0	0	0	0	0	0	0	0	
	Red	1	1	1	1	1	1	1	1	0	0	0	0	0	0	0	0	0	0	0	0	0	0	0	
	Green	0	0	0	0	0	0	0	0	1	1	1	1	1	1	1	1	0	0	0	0	0	0	0	
	Blue	0	0	0	0	0	0	0	0	0	0	0	0	0	0	0	0	1	1	1	1	1	1	1	
	Cyan	0	0	0	0	0	0	0	0	1	1	1	1	1	1	1	1	1	1	1	1	1	1	1	
	Magenta	1	1	1	1	1	1	1	1	0	0	0	0	0	0	0	0	1	1	1	1	1	1	1	
	Yellow	1	1	1	1	1	1	1	1	1	1	1	1	1	1	1	1	0	0	0	0	0	0	0	
	White	1	1	1	1	1	1	1	1	1	1	1	1	1	1	1	1	1	1	1	1	1	1	1	
Gray Scale Of Red	Red (0) / Dark	0	0	0	0	0	0	0	0	0	0	0	0	0	0	0	0	0	0	0	0	0	0		
	Red (1)	0	0	0	0	0	0	0	1	0	0	0	0	0	0	0	0	0	0	0	0	0	0		
	Red (2)	0	0	0	0	0	0	1	0	0	0	0	0	0	0	0	0	0	0	0	0	0	0		
	⋮	⋮	⋮	⋮	⋮	⋮	⋮	⋮	⋮	⋮	⋮	⋮	⋮	⋮	⋮	⋮	⋮	⋮	⋮	⋮	⋮	⋮	⋮		
	⋮	⋮	⋮	⋮	⋮	⋮	⋮	⋮	⋮	⋮	⋮	⋮	⋮	⋮	⋮	⋮	⋮	⋮	⋮	⋮	⋮	⋮	⋮		
	Red (253)	1	1	1	1	1	1	0	1	0	0	0	0	0	0	0	0	0	0	0	0	0	0		
	Red (254)	1	1	1	1	1	1	1	0	0	0	0	0	0	0	0	0	0	0	0	0	0	0		
	Red (255)	1	1	1	1	1	1	1	1	0	0	0	0	0	0	0	0	0	0	0	0	0	0		
Gray Scale Of Green	Green (0) / Dark	0	0	0	0	0	0	0	0	0	0	0	0	0	0	0	0	0	0	0	0	0	0		
	Green (1)	0	0	0	0	0	0	0	0	0	0	0	0	0	0	0	1	0	0	0	0	0	0		
	Green (2)	0	0	0	0	0	0	0	0	0	0	0	0	0	0	1	0	0	0	0	0	0	0		
	⋮	⋮	⋮	⋮	⋮	⋮	⋮	⋮	⋮	⋮	⋮	⋮	⋮	⋮	⋮	⋮	⋮	⋮	⋮	⋮	⋮	⋮	⋮		
	⋮	⋮	⋮	⋮	⋮	⋮	⋮	⋮	⋮	⋮	⋮	⋮	⋮	⋮	⋮	⋮	⋮	⋮	⋮	⋮	⋮	⋮	⋮		
	Green (253)	0	0	0	0	0	0	0	0	1	1	1	1	1	1	0	1	0	0	0	0	0	0		
	Green (254)	0	0	0	0	0	0	0	0	1	1	1	1	1	1	1	0	0	0	0	0	0	0		
	Green (255)	0	0	0	0	0	0	0	0	1	1	1	1	1	1	1	0	0	0	0	0	0	0		
Gray Scale Of Blue	Blue (0) / Dark	0	0	0	0	0	0	0	0	0	0	0	0	0	0	0	0	0	0	0	0	0	0		
	Blue (1)	0	0	0	0	0	0	0	0	0	0	0	0	0	0	0	0	0	0	0	0	0	1		
	Blue (2)	0	0	0	0	0	0	0	0	0	0	0	0	0	0	0	0	0	0	0	0	0	1		
	⋮	⋮	⋮	⋮	⋮	⋮	⋮	⋮	⋮	⋮	⋮	⋮	⋮	⋮	⋮	⋮	⋮	⋮	⋮	⋮	⋮	⋮	⋮		
	⋮	⋮	⋮	⋮	⋮	⋮	⋮	⋮	⋮	⋮	⋮	⋮	⋮	⋮	⋮	⋮	⋮	⋮	⋮	⋮	⋮	⋮	⋮		
	Blue (253)	0	0	0	0	0	0	0	0	0	0	0	0	0	0	0	1	1	1	1	1	1	0	1	
	Blue (254)	0	0	0	0	0	0	0	0	0	0	0	0	0	0	0	1	1	1	1	1	1	1	0	
	Blue (255)	0	0	0	0	0	0	0	0	0	0	0	0	0	0	0	1	1	1	1	1	1	1	1	

Note (1) 0: Low Level Voltage, 1: High Level Voltage

## 6. INTERFACE TIMING

### 6.1 INPUT SIGNAL TIMING SPECIFICATIONS

(Ta = 25 ± 2 °C)

The input signal timing specifications are shown as the following table and timing diagram.

Signal	Item	Symbol	Min.	Typ.	Max.	Unit	Note
LVDS Receiver Clock	Frequency	$F_{clk_{in}}$ (=1/TC)	60	74.25	80	MHz	
	Input cycle to cycle jitter	$T_{rcj}$	—	—	350	ps	(3)
	Spread spectrum modulation range	$F_{clk_{in\_mod}}$	$F_{clk_{in}}-2\%$	—	$F_{clk_{in}}+2\%$	MHz	(4)
	Spread spectrum modulation frequency	$F_{SSM}$	—	—	200	KHz	
LVDS Receiver Data	Receiver Skew Margin	$T_{RSKM}$	-400	—	400	ps	(5)
Vertical Active Display Term	Frame Rate	$F_{r5}$	47	50	53	Hz	(6)
		$F_{r6}$	57	60	63	Hz	
	Total	$T_v$	1115	1125	1135	Th	$T_v=T_{vd}+T_{vb}$
	Display	$T_{vd}$	1080	1080	1080	Th	
	Blank	$T_{vb}$	35	45	55	Th	
Horizontal Active Display Term	Total	$T_h$	1050	1100	1150	Tc	$T_h=T_{hd}+T_{hb}$
	Display	$T_{hd}$	960	960	960	Tc	
	Blank	$T_{hb}$	90	140	190	Tc	

Note (1) Please make sure the range of pixel clock has follow the below equation :

$$F_{clk_{in}(max)} \geq F_{r6} \times T_v \times T_h$$

$$F_{r5} \times T_v \times T_h \geq F_{clk_{in}(min)}$$

Note (2) This module is operated in DE only mode and please follow the input signal timing diagram below :

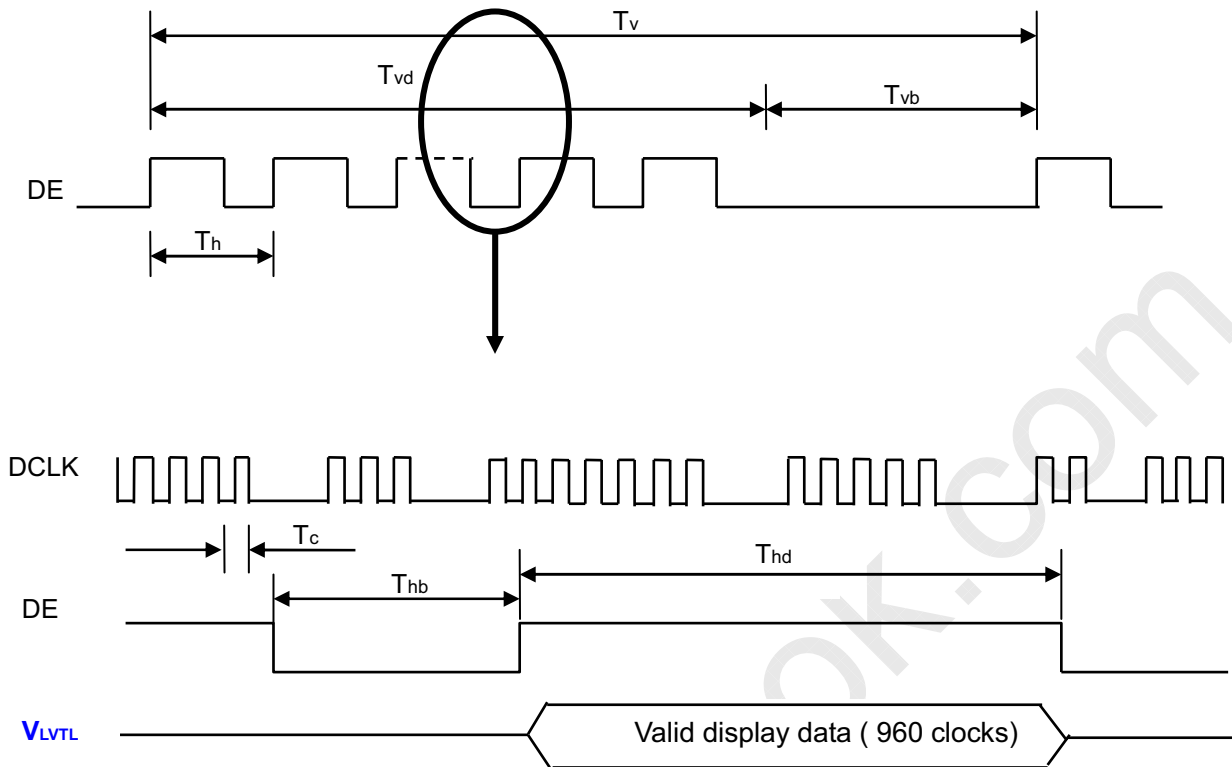

Note (3) The input clock cycle-to-cycle jitter is defined as below figures.  $Trcl = |T_1 - T_1|$

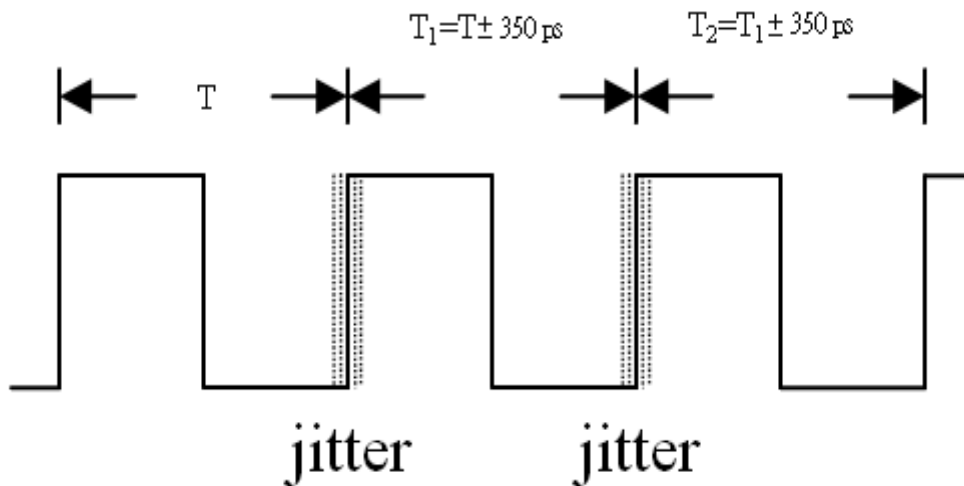

Note (4) The SSCG (Spread spectrum clock generator) is defined as below figures.

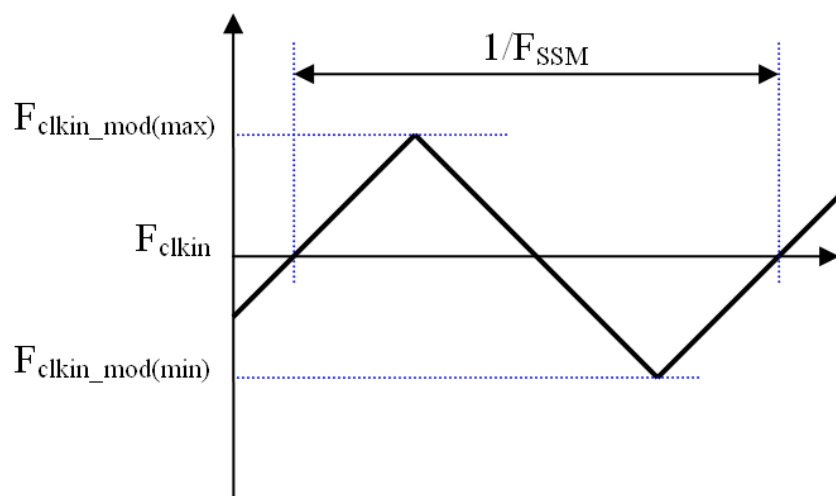

Note (5) LVDS receiver skew margin is defined and shown as below.

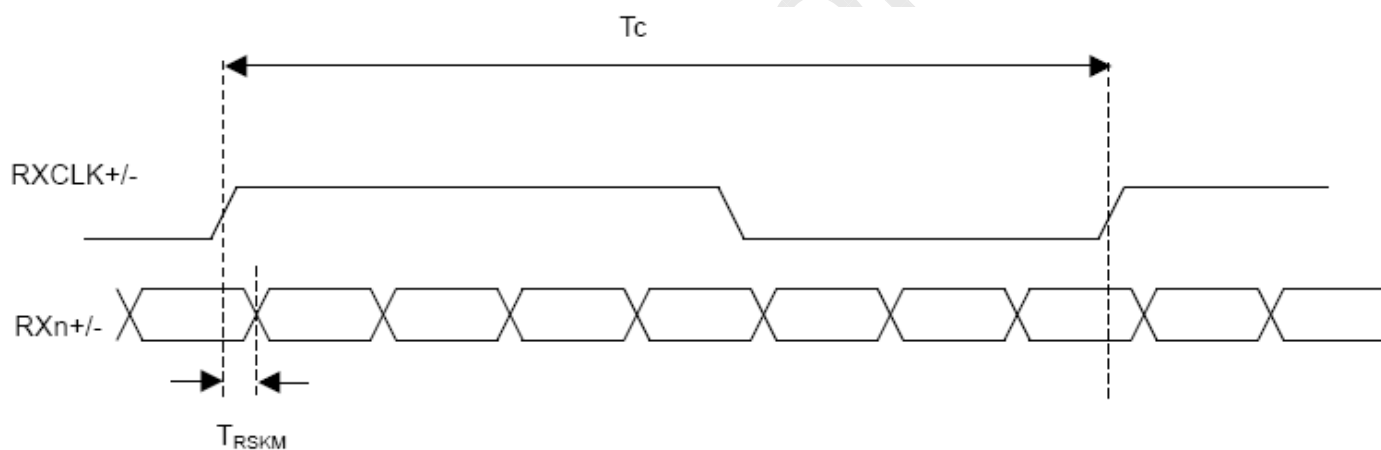



## 6.2 POWER ON/OFF SEQUENCE

( $T_a = 25 \pm 2 \text{ }^\circ\text{C}$ )

To prevent a latch-up or DC operation of LCD module, the power on/off sequence should be as the diagram below.

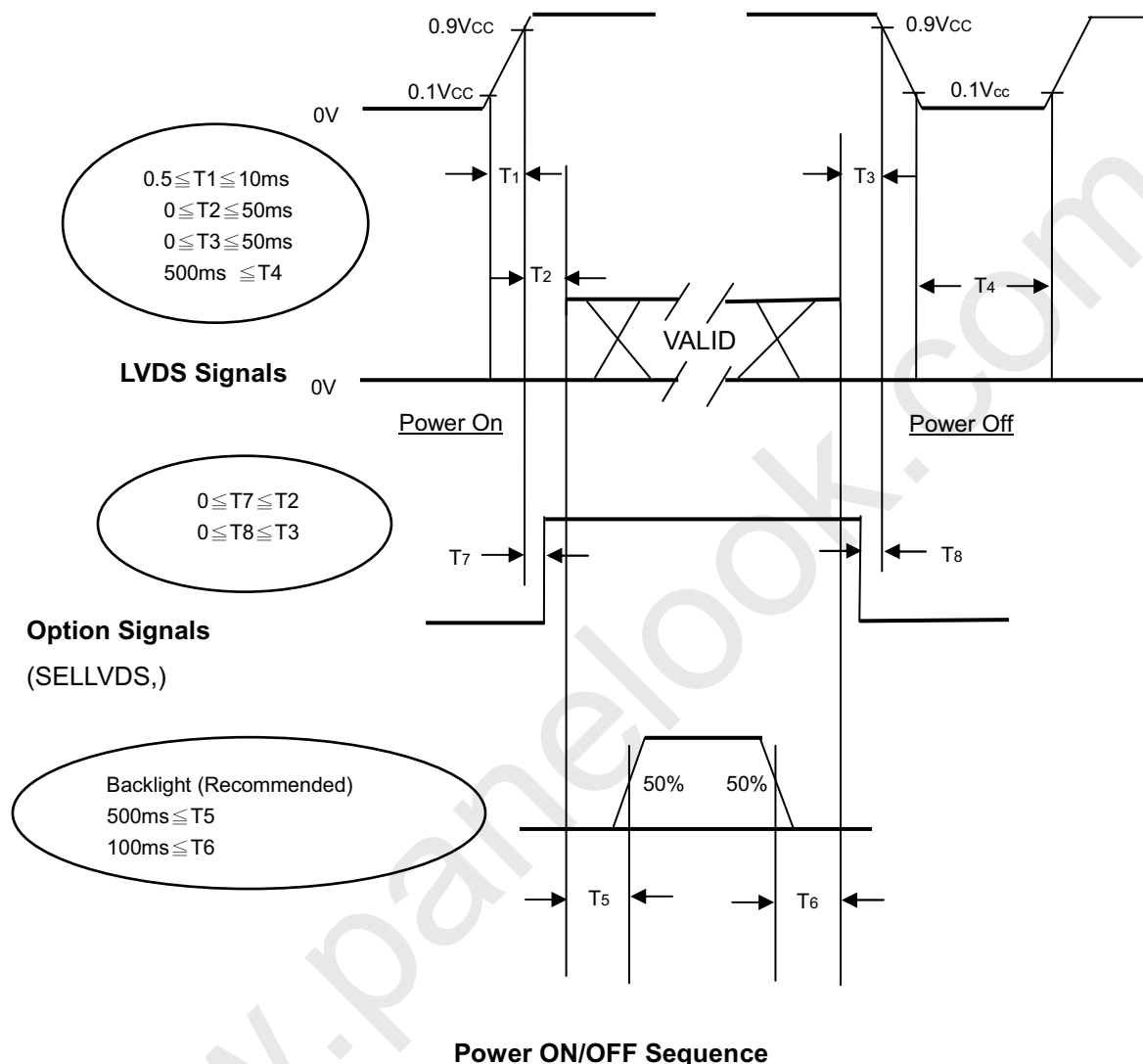

Note (1) The supply voltage of the external system for the module input should follow the definition of  $V_{cc}$ .

Note (2) Apply the lamp voltage within the LCD operation range. When the backlight turns on before the LCD operation or the LCD turns off before the backlight turns off, the display may momentarily become abnormal screen.

Note (3) In case of  $V_{CC}$  is in off level, please keep the level of input signals on the low or high impedance.  
If  $T2 < 0$ , that maybe cause electrical overstress failure.

Note (4)  $T4$  should be measured after the module has been fully discharged between power off and on period.

Note (5) Interface signal shall not be kept at high impedance when the power is on.

### OPTICAL CHARACTERISTICS

**7. OPTICAL CHARACTERISTICS**
**7.1 TEST CONDITIONS**

Item	Symbol	Value	Unit
Ambient Temperature	Ta	25±2	°C
Ambient Humidity	Ha	50±10	%RH
Supply Voltage	V <sub>CC</sub>	12V	V
Input Signal	According to typical value in "3. ELECTRICAL CHARACTERISTICS"		
LED Current	I <sub>L</sub>	170±5.1	mA

The LCD module should be stabilized at given temperature for 1 hour to avoid abrupt temperature change during measuring in a windless room.

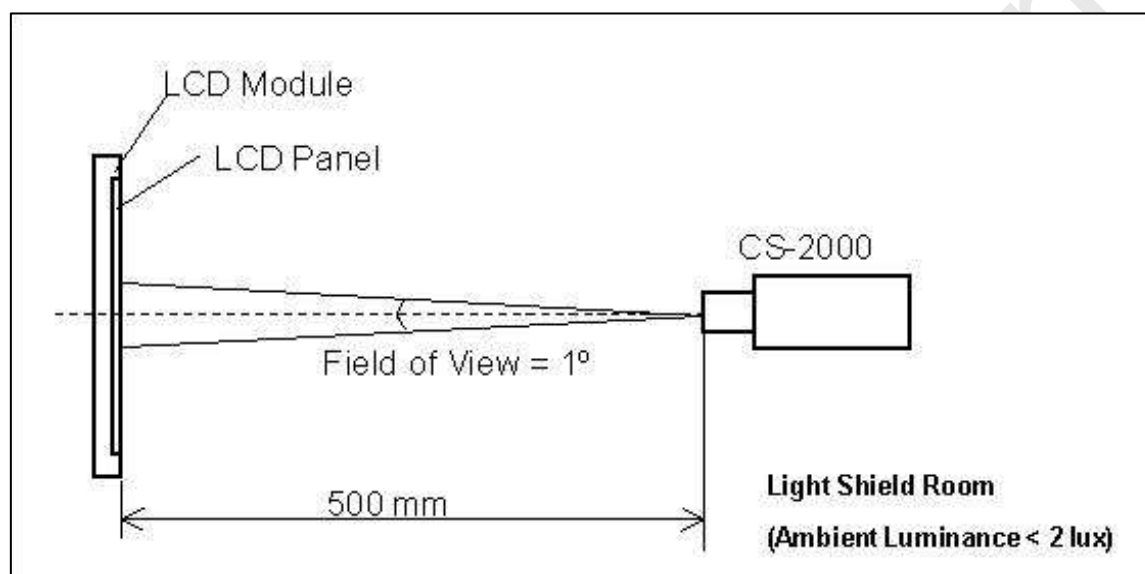

## 7.2 OPTICAL SPECIFICATIONS

The relative measurement methods of optical characteristics are shown in 7.2. The following items should be measured under the test conditions described in 7.1 and stable environment shown in 7.1.

Item		Symbol	Condition	Min.	Typ.	Max.	Unit	Note		
Contrast Ratio		CR	$\theta_x=0^\circ, \theta_y=0^\circ$ Viewing angle at normal direction	3500	5000	-	-	(2)		
Response Time (VA)		Gray to gray		-	8	16	ms	(3)		
Center Luminance of White		$L_c$		280	350	-	$\text{cd/m}^2$	(4)		
White Variation		$\delta W$		-	-	1.3	-	(6)		
Cross Talk		CT		-	-	4	%	(5)		
Color Chromaticity	Red	Rx		Typ. -0.03	0.645	0.330	Typ. +0.03	-	-	
		Ry								
	Green	Gx								0.298
		Gy								0.600
	Blue	Bx								0.148
		By	0.056							
	White	Wx	0.280							
		Wy	0.290							
Color Gamut		C.G	-	72	-	%	NTSC			
Viewing Angle	Horizontal	$\theta_{x+}$	CR $\geq$ 20	80	88	-	Deg.	(1)		
		$\theta_{x-}$								
	Vertical	$\theta_{Y+}$								
		$\theta_{Y-}$								

Note (1) Definition of Viewing Angle ( $\theta_x$ ,  $\theta_y$ ) :

Viewing angles are measured by Conoscope Cono-80 ( or Eldim EZ-Contrast 160R)

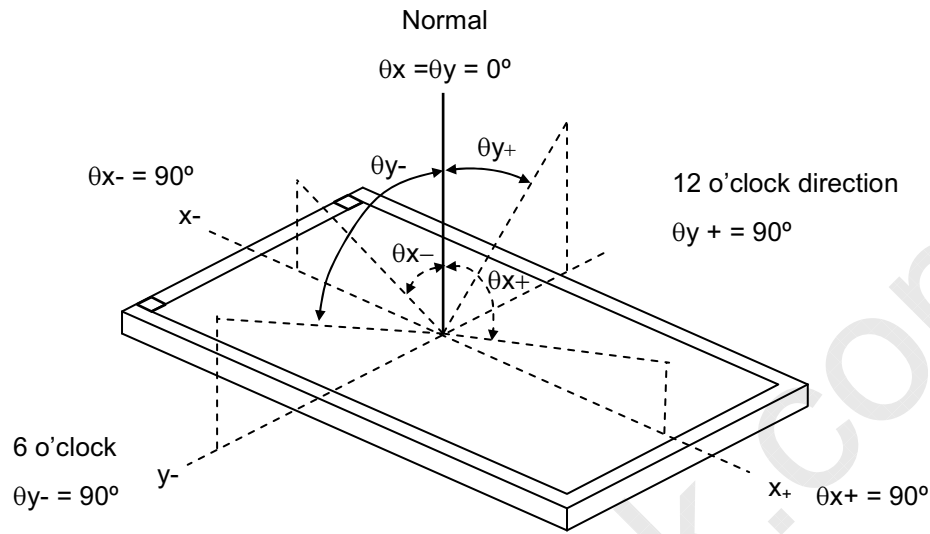

Note (2) Definition of Contrast Ratio (CR) :

The contrast ratio can be calculated by the following expression.

$$\text{Contrast Ratio (CR)} = \frac{\text{Surface Luminance of L255}}{\text{Surface Luminance of L0}}$$

L255: Luminance of gray level 255

L 0: Luminance of gray level 0

CR = CR (5), where CR (X) is corresponding to the Contrast Ratio of the point X at the figure in Note (6).

Note (3) Definition of Gray-to-Gray Switching Time:

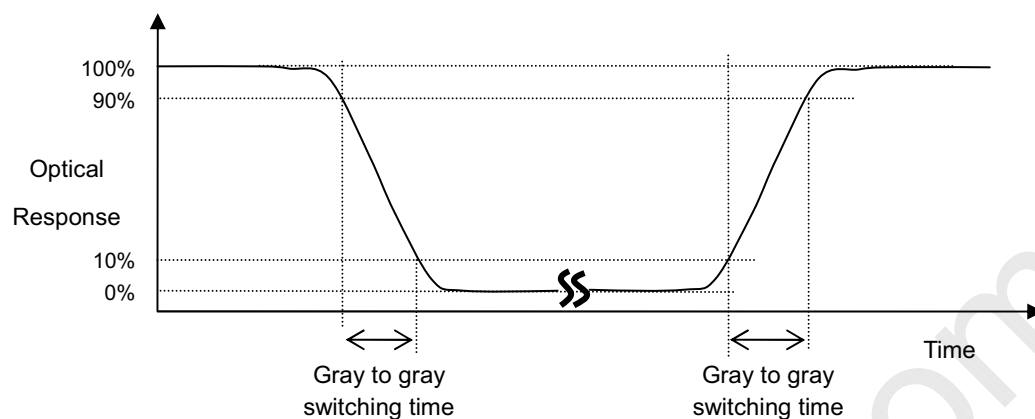

The driving signal means the signal of gray level 0, 124, 252, 380, 508, 636, 764, 892 and 1023.

Gray to gray average time means the average switching time of gray level 0, 124, 252, 380, 508, 636, 764, 892 and 1023 to each other.

Note (3) Definition of Response Time ( $T_R$ ,  $T_F$ ):

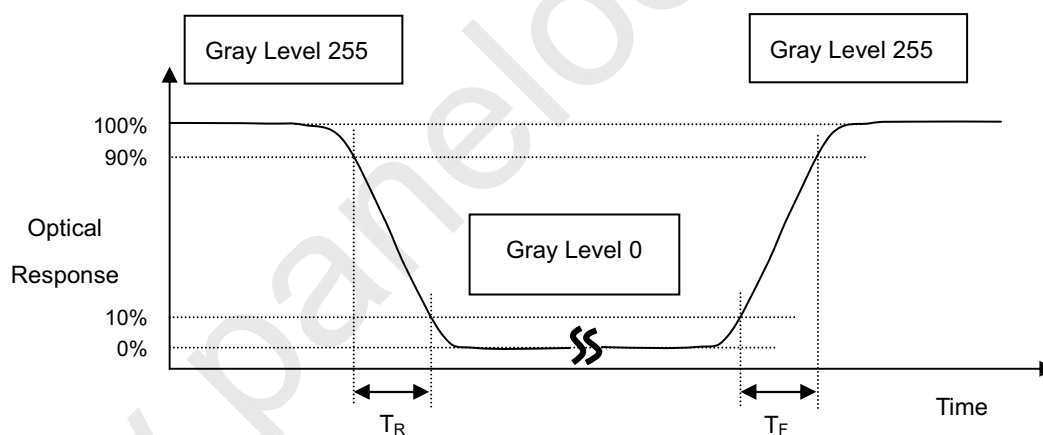

Note (4) Definition of Luminance of White ( $L_C$ ):

Measure the luminance of gray level 255 at center point and 5 points

$L_C = L(5)$ , where  $L(X)$  is corresponding to the luminance of the point  $X$  at the figure in Note (6).

Note (5) Definition of Cross Talk (CT):

$$CT = |Y_B - Y_A| / Y_A \times 100 (\%)$$

Where:

$Y_A$  = Luminance of measured location without gray level 0 pattern (cd/m<sup>2</sup>)

$Y_B$  = Luminance of measured location with gray level 0 pattern (cd/m<sup>2</sup>)

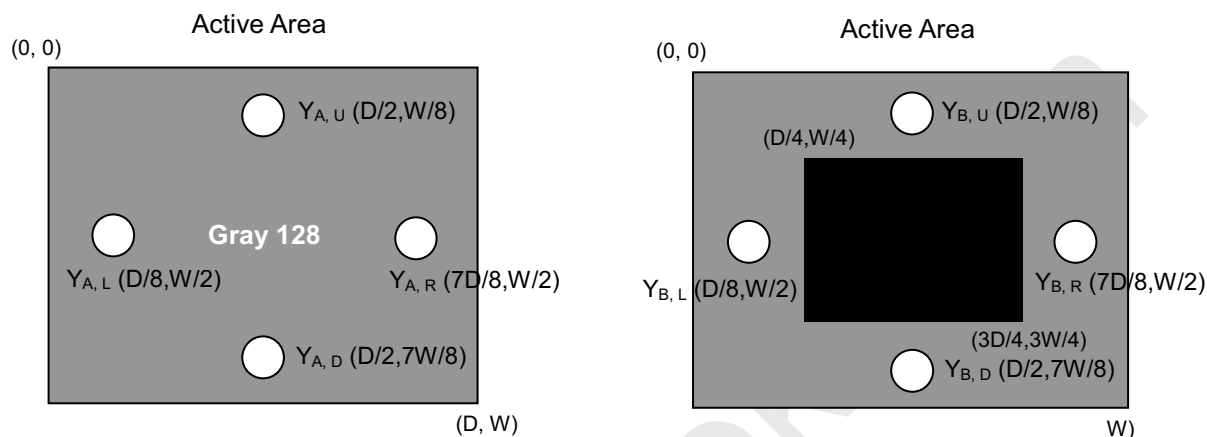

$Y_A$  = Luminance of measured location without gray level 255 pattern (cd/m<sup>2</sup>)

$Y_B$  = Luminance of measured location with gray level 255 pattern (cd/m<sup>2</sup>)

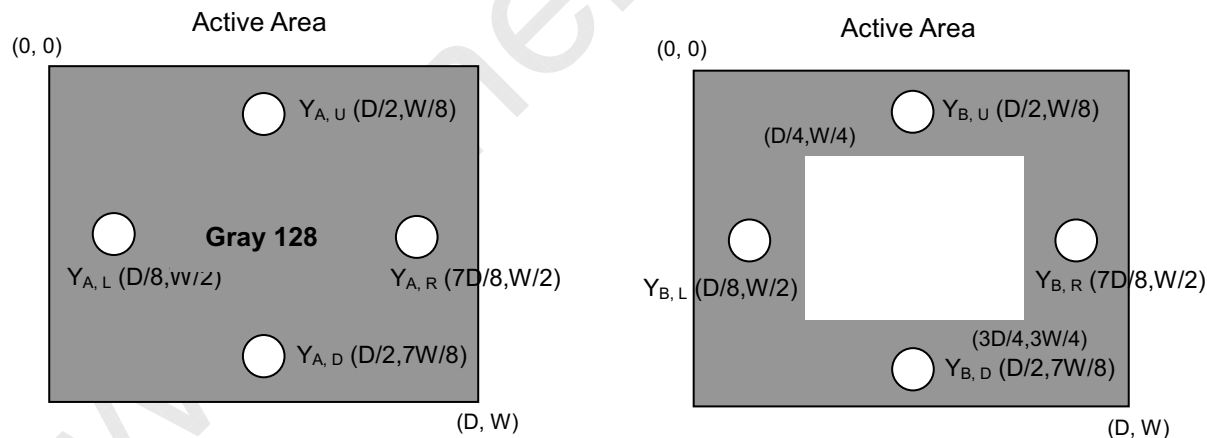

Note (6) Definition of White Variation ( $\delta W$ ):

Measure the luminance of gray level 255 at 5 points

$$\delta W = \text{Maximum [L (1), L (2), L (3), L (4), L (5)]} / \text{Minimum [L (1), L (2), L (3), L (4), L (5)]}$$

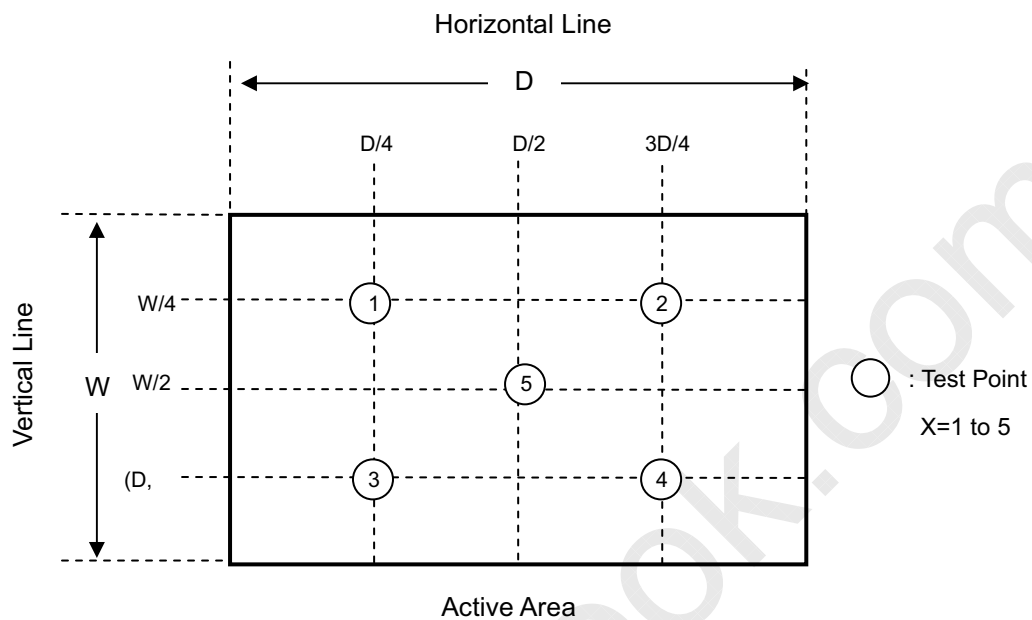

## 8 PRECAUTIONS

### 8.1 ASSEMBLY AND HANDLING PRECAUTIONS

- [ 1 ] Do not apply rough force such as bending or twisting to the module during assembly.
- [ 2 ] It is recommended to assemble or to install a module into the user's system in clean working areas. The dust and oil may cause electrical short or worsen the polarizer.
- [ 3 ] Do not apply pressure or impulse to the module to prevent the damage of LCD panel and Backlight.
- [ 4 ] Always follow the correct power-on sequence when the LCD module is turned on. This can prevent the damage and latch-up of the CMIS LSI chips.
- [ 5 ] Bezel of Set can not press or touch the panel surface. It will make light leakage or scrape.
- [ 6 ] Do not plug in or pull out the I/F connector while the module is in operation.
- [ 7 ] Do not disassemble the module.
- [ 8 ] Use a soft dry cloth without chemicals for cleaning, because the surface of polarizer is very soft and easily scratched.
- [ 9 ] Moisture can easily penetrate into LCD module and may cause the damage during operation.
- [ 10 ] When storing modules as spares for a long time, the following precaution is necessary.
  - [ 10.1 ] Do not leave the module in high temperature, and high humidity for a long time. It is highly recommended to store the module with temperature from 0 to 35°C at normal humidity without condensation.
  - [ 10.2 ] The module shall be stored in dark place. Do not store the TFT-LCD module in direct sunlight or fluorescent light.
- [ 11 ] When ambient temperature is lower than 10°C, the display quality might be reduced. For example, the response time will become slow, and the starting voltage of CCFL will be higher than that of room temperature.

### 8.2 SAFETY PRECAUTIONS

- [ 1 ] The startup voltage of a Backlight is approximately 1000 Volts. It may cause an electrical shock while assembling with the inverter. Do not disassemble the module or insert anything into the Backlight unit.
- [ 2 ] If the liquid crystal material leaks from the panel, it should be kept away from the eyes or mouth. In case of contact with hands, skin or clothes, it has to be washed away thoroughly with soap.
- [ 3 ] After the module's end of life, it is not harmful in case of normal operation and storage.

### 8.3 SAFETY REVIEW

#### 8.3.1 SAFETY STANDARDS

The LCD module should be certified with safety regulations as follows:

Requirement	Standard	Remark
UL	UL60950-1:2006 or Ed.2:2007	
	UL60065 Ed.7:2007	
cUL/CSA	CAN/CSA C22.2 No.60950-1-03 or 60950-1-07	
	CAN/CSA C22.2 No.60065-03:2006 + A1:2006	
CB	IEC60950-1:2005 / EN60950-1:2006+ A11:2009	
	IEC60065:2001+ A1:2005 / EN60065:2002 + A1:2006 + A11:2008	



## 9. DEFINITION OF LABELS

### 9.1 CMI MODULE LABEL

The barcode nameplate is pasted on each module as illustration, and its definitions are as following explanation.

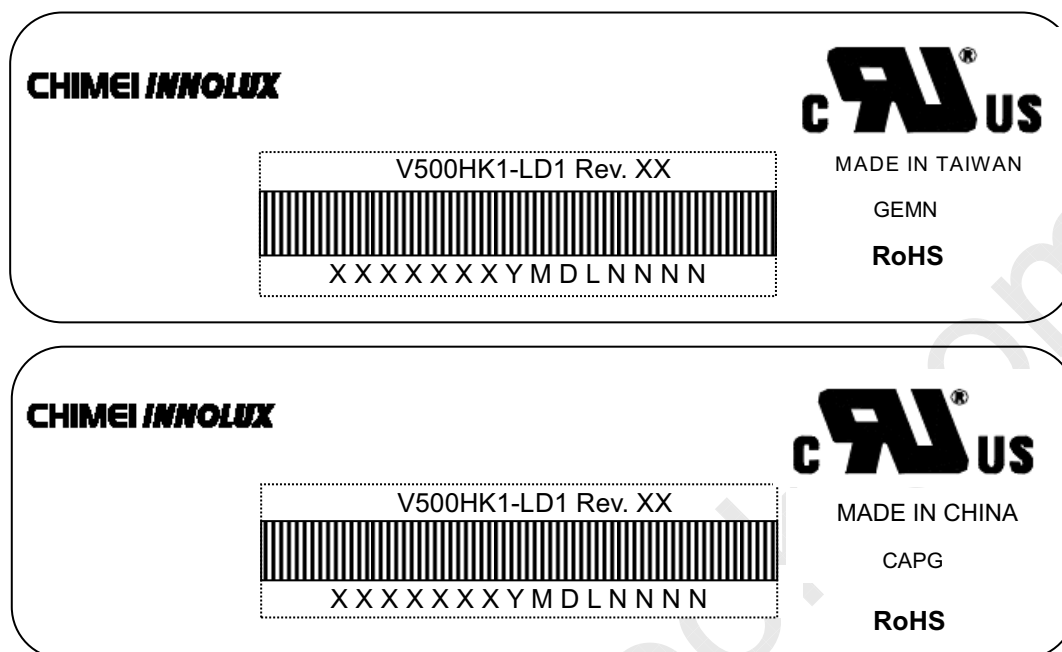

Model Name: V500HK1-LD1

Revision: Rev. XX, for example: A0, A1... B1, B2... or C1, C2...etc.

Serial ID: X X X X X X Y M D L N N N

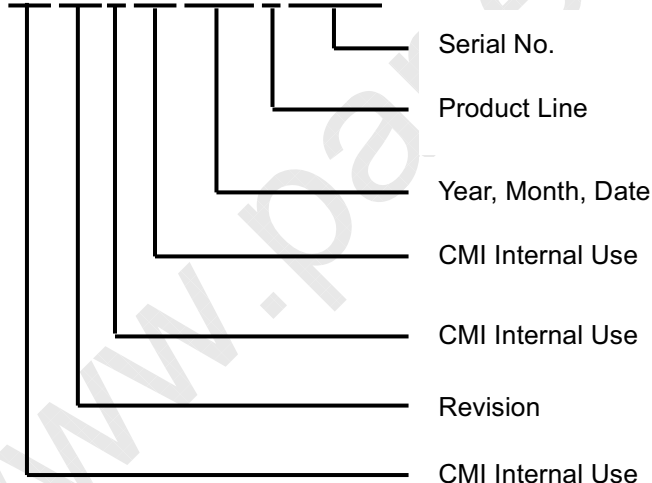

Serial ID includes the information as below:

Manufactured Date:

Year : 2001=1, 2002=2, 2003=3, 2004=4...2010=0, 2011=1, 2012=2...

Month: 1~9, A~C, for Jan. ~ Dec.

Day: 1~9, A~Y, for 1st to 31st, exclude I ,O, and U.

Revision Code : Cover all the change

Serial No. : Manufacturing sequence of product

Product Line : 1 → Line1, 2 → Line 2, ...etc.

## 10. PACKAGING

### 10.1 PACKAGING SPECIFICATIONS

- (1) 4 LCD TV modules / 1 Box
- (2) Box dimensions : 1235(L)x345(W)x751(H)mm
- (3) Weight : Approx. 56.6Kg(4 modules per carton)

### 10.2 PACKAGING METHOD

Figures 10-1 and 10-2 are the packing method

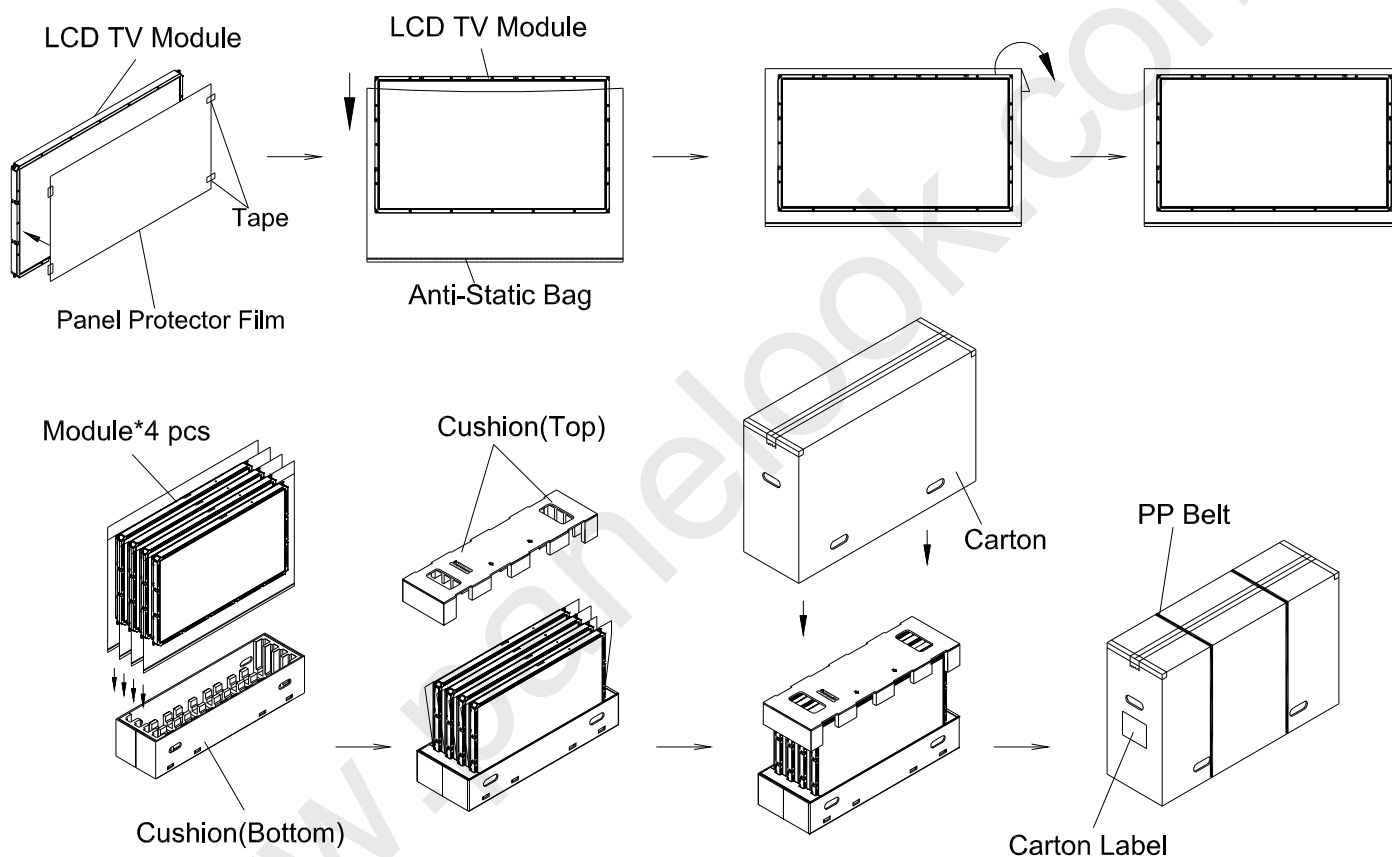
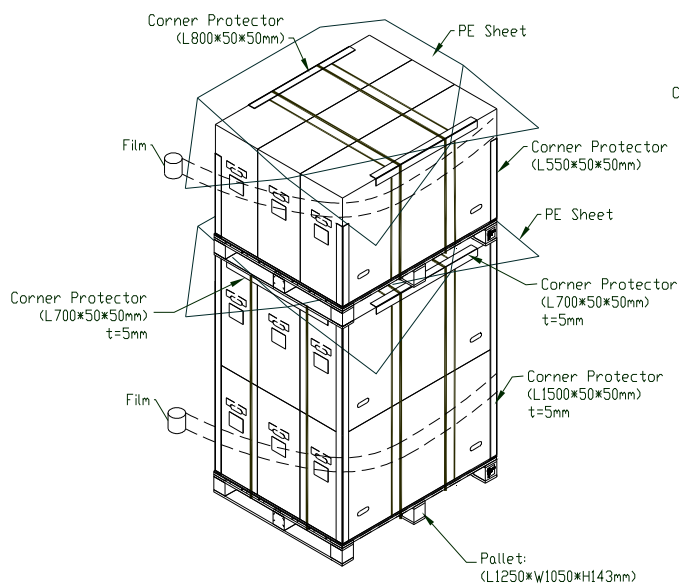
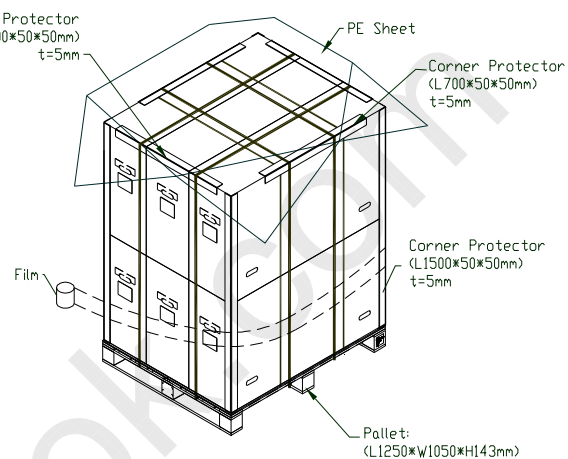

Figure 10-1 packing method

## Sea / Land Transportation (40ft HQ Container)



## Sea / Land Transportation (40ft/20ft Container)



## Air Transportation

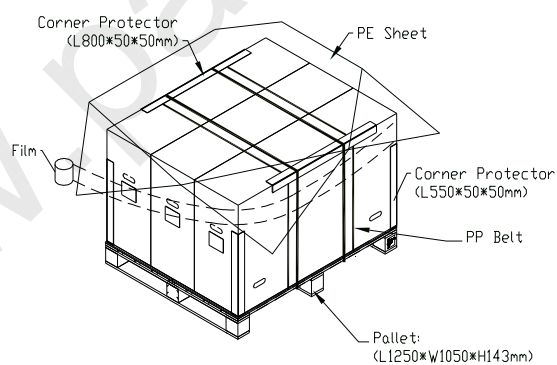
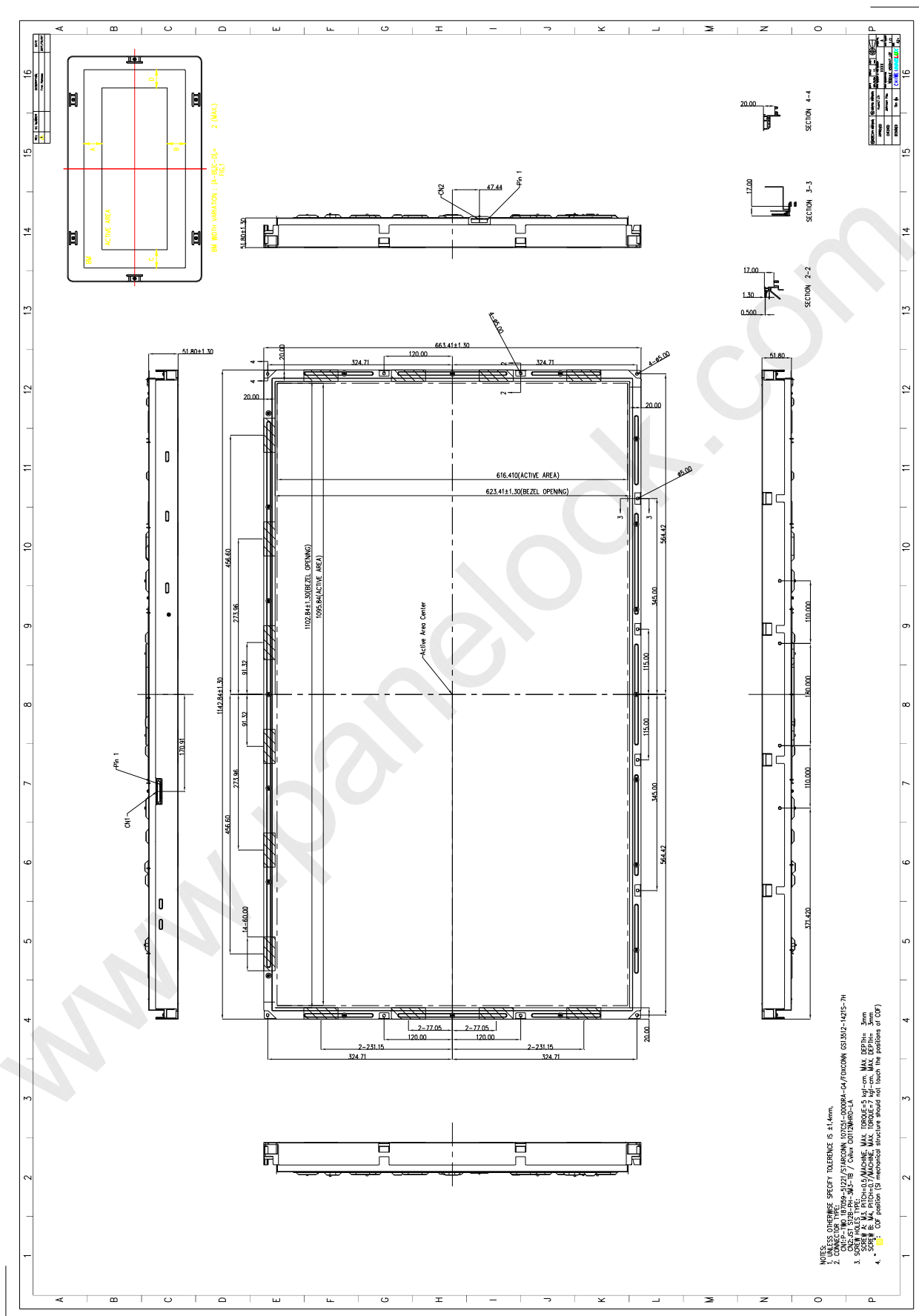
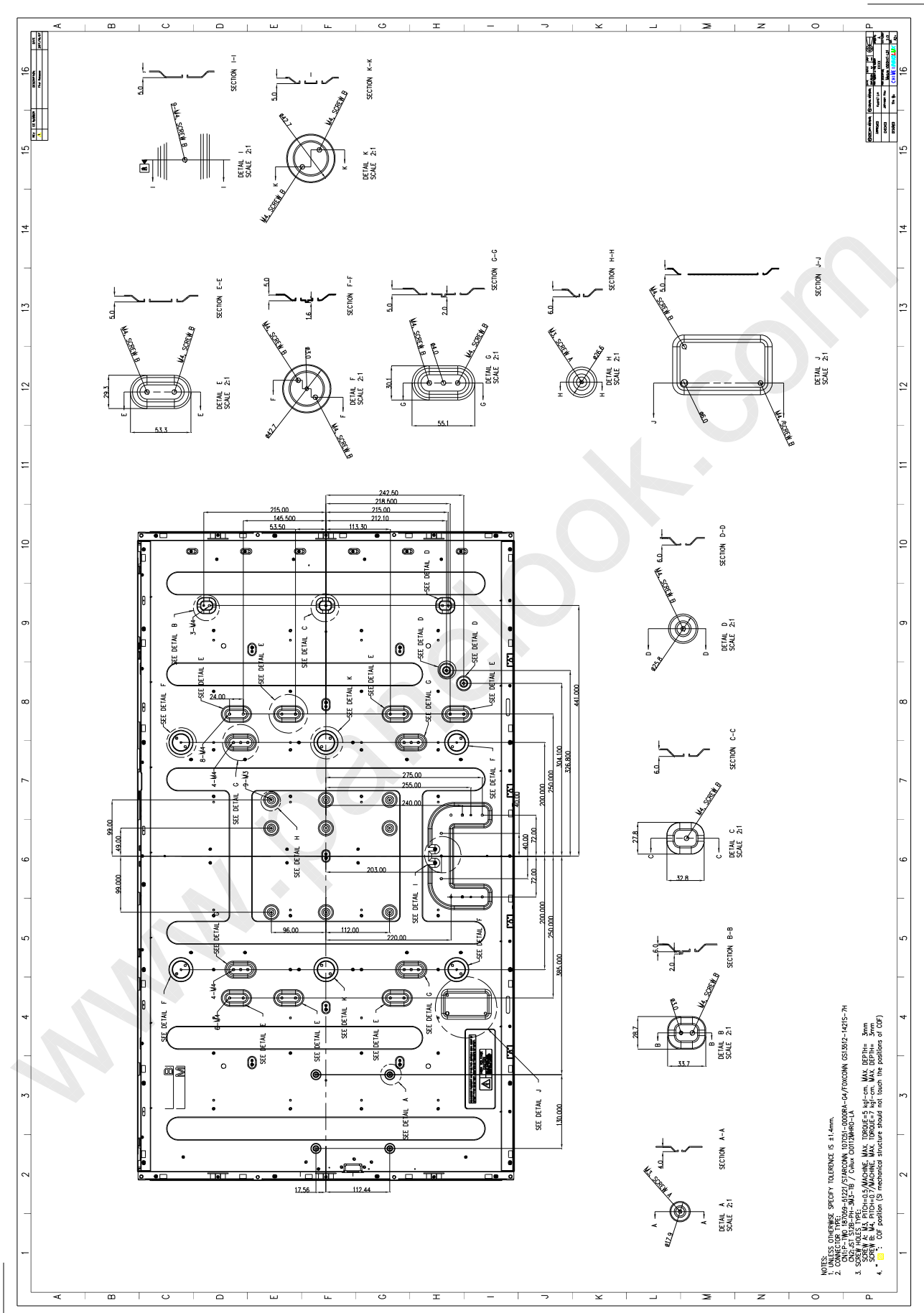

Figure 10-2 packing method

## 11. MECHANICAL CHARACTERISTIC





NOTES:  
 1. SURFACE SPECIFY TOLERANCE IS ±1.4mm.  
 2. CONNECTION TYPE:  
 CONTOUR: NO. 10/2009-0122/57ARCOWA, 10703-0000A-66/70CONN, GS1502-14215-7H  
 CONTOUR: NO. 10/2009-0122/57ARCOWA, 10703-0000A-66/70CONN, GS1502-14215-7H  
 3. SCREW MOUNT TYPE: MAX. TORQUE: 7.0gf-cm. MAX. DEPTH: 3mm  
 SCREW B: MAX. TORQUE: 7.0gf-cm. MAX. DEPTH: 3mm  
 4. \* COP position (Si mechanical structure should not touch the positions of COP)