

- Tentative Specification
- Preliminary Specification
- Approval Specification

MODEL NO.: V500HK1

SUFFIX: PD1

Customer:	
APPROVED BY	SIGNATURE
<u>Name / Title</u> _____	
Note	

Please return 1 copy for your confirmation with your signature and comments.	

Approved By	Checked By	Prepared By
Chao-Chun Chung	Ken Wu	HT Hung

CONTENTS

REVISION HISTORY.....	4
1. GENERAL DESCRIPTION.....	5
1.1 OVERVIEW.....	5
1.2 FEATURES.....	5
1.3 MECHANICAL SPECIFICATIONS.....	5
2. ABSOLUTE MAXIMUM RATINGS.....	6
2.1 ABSOLUTE RATINGS OF ENVIRONMENT.....	6
2.2 PACKAGE STORAGE.....	7
3. ELECTRICAL CHARACTERISTICS.....	8
3.1 TFT LCD Module.....	8
4. BLOCK DIAGRAM OF INTERFACE.....	11
4.1 TFT LCD MODULE.....	11
5. INPUT TERMINAL PIN ASSIGNMENT.....	12
5.1 TFT LCD OPEN CELL.....	12
5.2 BLOCK DIAGRAM OF INTERFACE.....	16
5.3 LVDS INTERFACE.....	17
5.4 COLOR DATA INPUT ASSIGNMENT.....	18
6. INTERFACE TIMING.....	21
6.1 INPUT SIGNAL TIMING SPECIFICATIONS.....	21
6.2 POWER ON/OFF SEQUENCE (Ta = 25 ± 2 °C).....	26
7. OPTICAL CHARACTERISTICS.....	29
7.1 TEST CONDITIONS.....	29
7.2 OPTICAL SPECIFICATIONS.....	30
8. PRECAUTIONS.....	34
8.1 ASSEMBLY AND HANDLING PRECAUTIONS.....	34
8.2 SAFETY PRECAUTIONS.....	34
9. DEFINITION OF LABELS.....	35

9.1 OPEN CELL LABEL	35
9.2 CARTON LABEL	37
10. Packaging	38
10.1 PACKING SPECIFICATIONS.....	38
10.2 PACKING METHOD	38
11. MECHANICAL CHARACTERISTIC.....	40

REVISION HISTORY

Version	Date	Page (New)	Section	Description
Ver. 0.0	Nov. 18,2011	All	All	The Tentative specification was first issued.

1. GENERAL DESCRIPTION

1.1 OVERVIEW

V500HK1-PD1 is a 50" TFT Liquid Crystal Display product with driver ICs and 2ch-LVDS interface. This product supports 1920 x 1080 HDTV format and can display true 16.7M colors (8-bit /color). The backlight unit is not built in.

1.2 FEATURES

CHARACTERISTICS ITEMS	SPECIFICATIONS
Pixels [lines]	1920 x 1080
Active Area [mm]	1095.84(H) x (V) 616.41
Sub-Pixel Pitch [mm]	0.21(H) x 0.63(V)
Pixel Arrangement	RGB vertical stripe
Weight [g]	2910
Physical Size [mm]	1110.44 (W) x 631.61(H) x 1.705(D) Typ
Display Mode	Transmissive mode / Normally black
Contrast Ratio	5000:1 Typ.(Typical value measured at CMI's module)
Glass thickness (Array / CF) [mm]	0.7 / 0.7
Viewing Angle (CR>20)	+88/-88(H),+88/-88(V) Typ. (Typical value measured at CMI's module)
Color Chromaticity	R=0.661, 0.322 G=0.261, 0.579 B=0.135, 0.095 W=0.293, 0.339 * Please refer to "color chromaticity" on 7.2
Cell Transparency [%]	(TBD)% Typ. (Typical value measured at CMI's module)
Polarizer Surface Treatment	Anti-Glare coating (Haze 3.5%)Hardness 3H

1.3 MECHANICAL SPECIFICATIONS

Item	Min.	Typ.	Max.	Unit	Note
Weight	-	3450	-	g	-
I/F connector mounting position	The mounting inclination of the connector makes the screen center within $\pm 0.5\text{mm}$ as the horizontal.				(2)

Note (1) Please refer to the attached drawings for more information of front and back outline dimensions.

Note (2) Connector mounting position

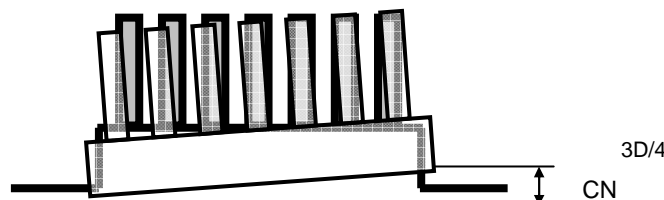

2. ABSOLUTE MAXIMUM RATINGS

2.1 ABSOLUTE RATINGS OF ENVIRONMENT

Item	Symbol	Value		Unit	Note
		Min.	Max.		
Storage Temperature	T _{ST}	-20	+60	°C	(1), (3)
Operating Ambient Temperature	T _{OP}	0	50	°C	(1), (2), (3)

Note (1) Temperature and relative humidity range is shown in the figure below.

- (a) 90 %RH Max. (Ta ≤ 40 °C).
- (b) Wet-bulb temperature should be 39 °C Max. (Ta > 40 °C).
- (c) No condensation.

Note (2) The maximum operating temperature is based on the test condition that the surface temperature of display area is less than or equal to 65 °C with LCD module alone in a temperature controlled chamber. Thermal management should be considered in final product design to prevent the surface temperature of display area from being over 65 °C. The range of operating temperature may degrade in case of improper thermal management in final product design.

Note (3) The rating of environment is base on LCD module. Leave LCD cell alone, this environment condition can't be guaranteed. Except LCD cell, the customer has to consider the ability of other parts of LCD module and LCD module process.

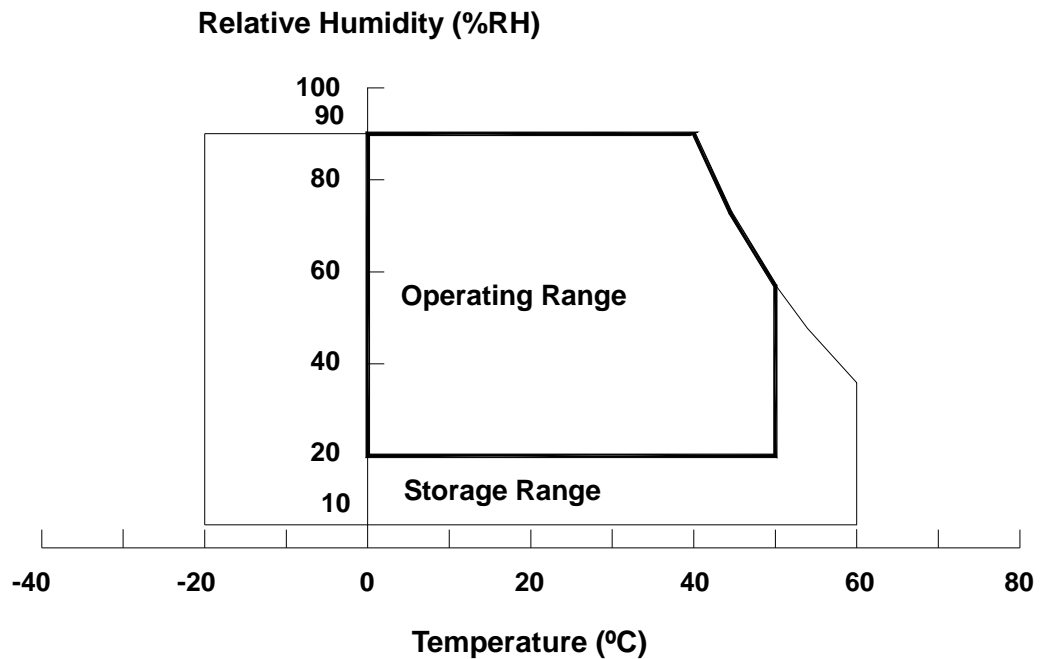

2.2 PACKAGE STORAGE

When storing modules as spares for a long time, the following precaution is necessary.

- (a) Do not leave the module in high temperature, and high humidity for a long time, It is highly recommended to store the module with temperature from 0 to 35 °C at normal humidity without condensation.
- (b) The module shall be stored in dark place. Do not store the TFT-LCD module in direct sunlight or fluorescent light.

3. ELECTRICAL CHARACTERISTICS

3.1 TFT LCD Module

(Ta = 25 ± 2 °C)

Parameter		Symbol	Value			Unit	Note
			Min.	Typ.	Max.		
Power Supply Voltage		V _{CC}	10.8	12	13.2	V	(1)
Rush Current		I _{RUSH}	—	—	(4.8)	A	(2)
Power Consumption	White Pattern	—	—	(7.32)		W	(3)
	Horizontal Stripe	—	—	(15.84)	(19.68)	W	
	Black Pattern	—	—	(7.44)		W	
Power Supply Current	White Pattern	—	—	(0.61)	—	A	
	Horizontal Stripe	—	—	(1.32)	(1.64)	A	
	Black Pattern	—	—	(0.62)	—	A	
LVDS interface	Differential Input High Threshold Voltage	V _{LVTH}	+100	—	—	mV	(4)
	Differential Input Low Threshold Voltage	V _{LVTL}	—	—	-100	mV	
	Common Input Voltage	V _{CM}	1.0	1.2	1.4	V	
	Differential input voltage (single-end)	V _{ID}	200	—	600	mV	
	Terminating Resistor	R _T	—	100	—	ohm	
CMIS interface	Input High Threshold Voltage	V _{IH}	2.7	—	3.3	V	
	Input Low Threshold Voltage	V _{IL}	0	—	0.7	V	

Note (1) The module should be always operated within the above ranges.

Note (2) Measurement condition:

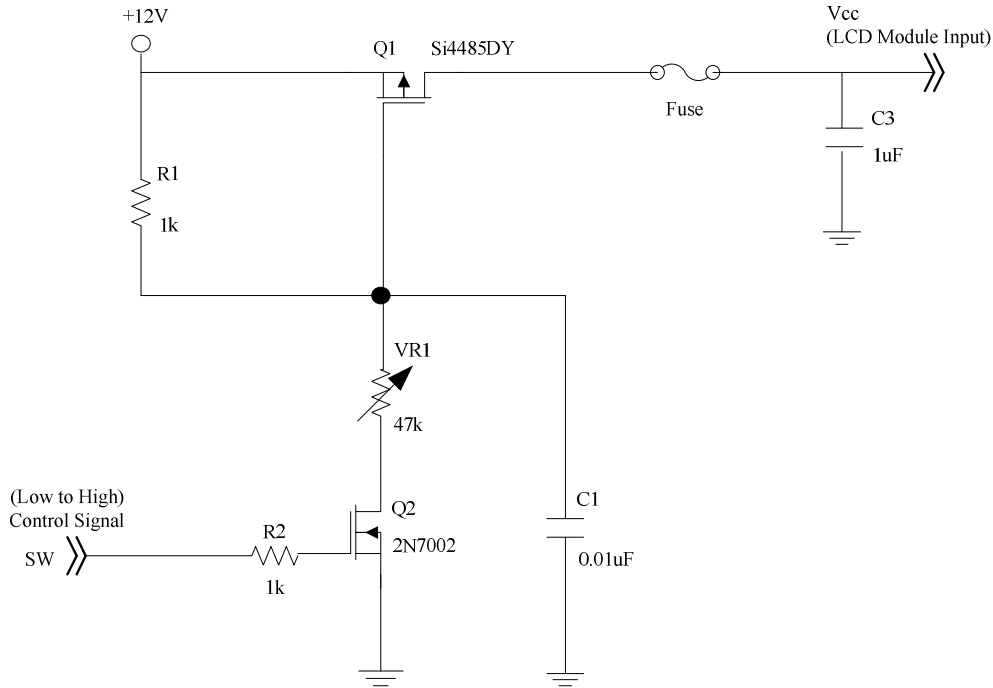

Vcc rising time is 470us

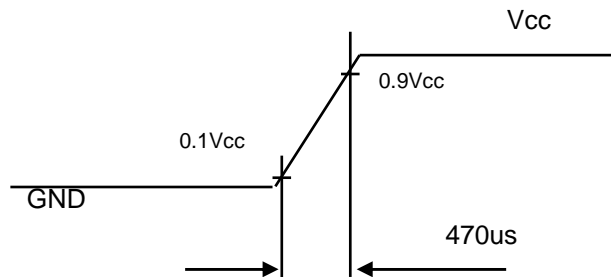

Note (3) The specified power consumption and power supply current is under the conditions at $V_{cc} = 12\text{ V}$, $T_a = 25 \pm 2\text{ }^\circ\text{C}$, $f_v = 60\text{ Hz}$, whereas a power dissipation check pattern below is displayed.

Note (4) The specified power supply current is under the conditions at $V_{cc} = 12\text{ V}$, $T_a = 25 \pm 2\text{ }^\circ\text{C}$, $f_v = 60\text{ Hz}$, whereas a power dissipation check pattern below is displayed.

a. White Pattern



Active Area

b. Black Pattern



Active Area

c. Horizontal Pattern

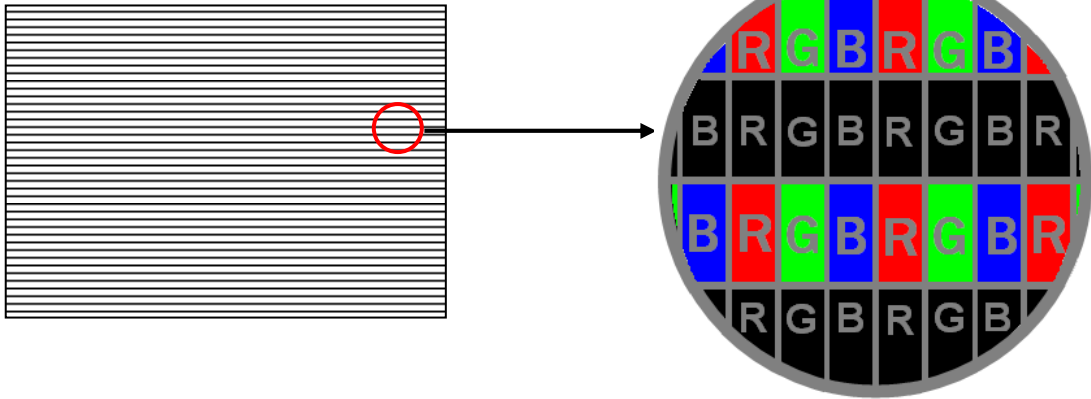

Note (4) The LVDS input characteristics are as follows:

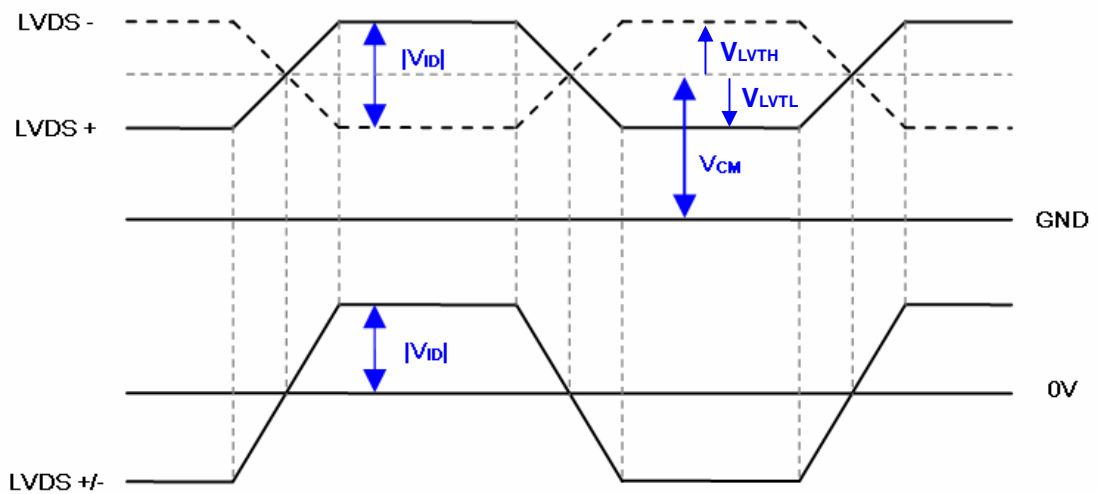

4. BLOCK DIAGRAM OF INTERFACE

4.1 TFT LCD MODULE

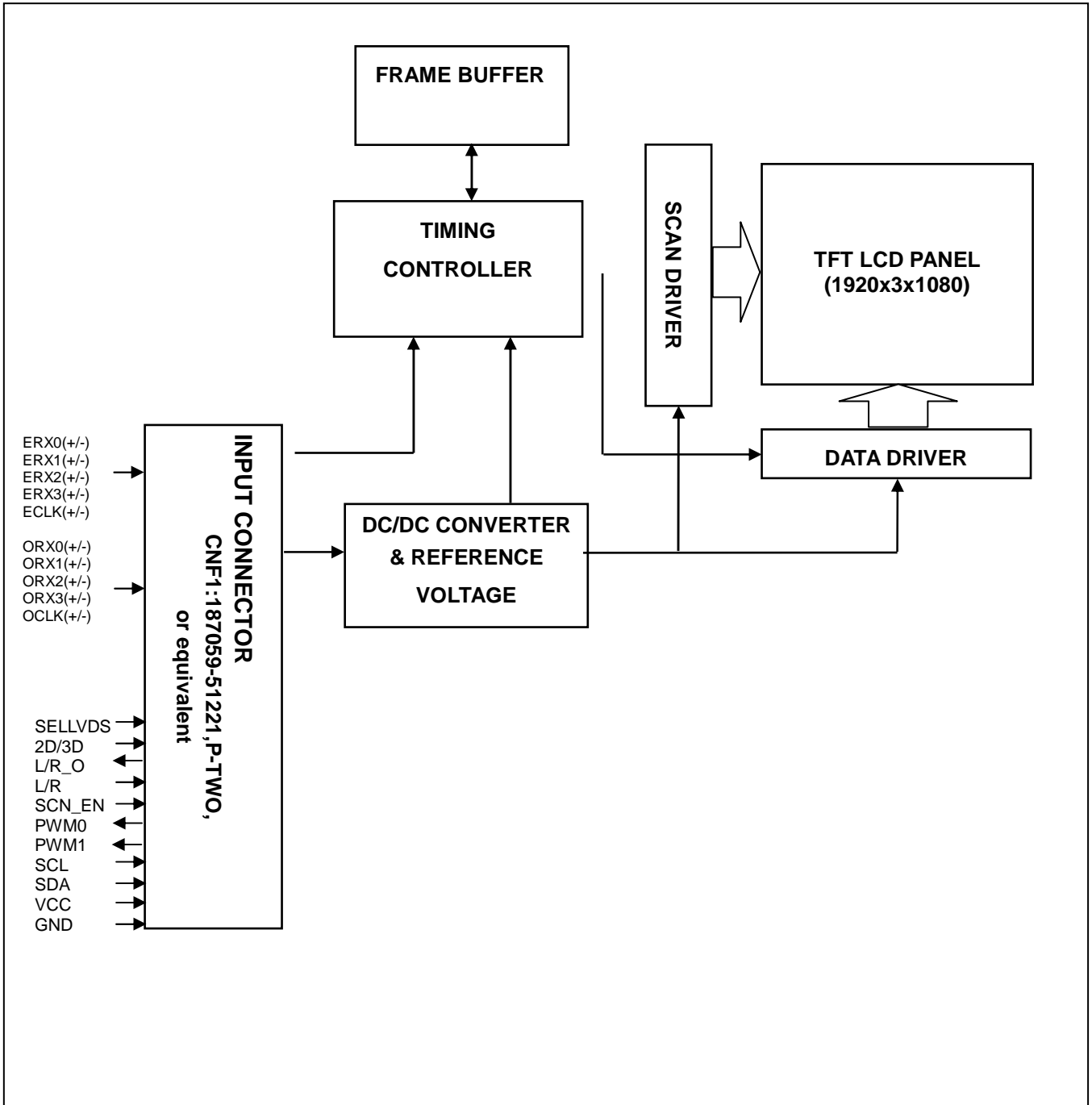

5 .INPUT TERMINAL PIN ASSIGNMENT

5.1 TFT LCD OPEN CELL

CNF1 Connector Part No.: B-F,WF23-400-513C,(全康-FCN) or equivalent.

Pin	Name	Description	Note
1	N.C.	No Connection	(1)
2	SCL	I2C Serial Clock (reserved for 3D format selection function)	(10)
3	SDA	I2C Serial Data (reserved for 3D format selection function)	
4	N.C.	No Connection	(1)
5	L/R_O	Output signal for Left Right Glasses control	(9)
6	N.C.	No Connection	(1)
7	SELLVDS	Input signal for LVDS Data Format Selection	(2)(6)
8	N.C.	No Connection	(1)
9	PWM0	Upper side scanning B/L signal in 3D mode (no reverse panel)	(11)
10	PWM1	Lower side scanning B/L signal in 3D mode (no reverse panel)	
11	GND	Ground	
12	ORX0-	Odd pixel Negative LVDS differential data input. Channel 0	(8)
13	ORX0+	Odd pixel Positive LVDS differential data input. Channel 0	
14	ORX1-	Odd pixel Negative LVDS differential data input. Channel 1	
15	ORX1+	Odd pixel Positive LVDS differential data input. Channel 1	
16	ORX2-	Odd pixel Negative LVDS differential data input. Channel 2	
17	ORX2+	Odd pixel Positive LVDS differential data input. Channel 2	
18	GND	Ground	
19	OCLK-	Odd pixel Negative LVDS differential clock input	(8)
20	OCLK+	Odd pixel Positive LVDS differential clock input	
21	GND	Ground	
22	ORX3-	Odd pixel Negative LVDS differential data input. Channel 3	(8)
23	ORX3+	Odd pixel Positive LVDS differential data input. Channel 3	
24	N.C.	No Connection	(1)
25	N.C.	No Connection	
26	2D/3D	Input signal for 2D/3D Mode Selection	(3)(5)(7)
27	L/R	Input signal for Left Right eye frame synchronous	(4)(7)
28	ERX0-	Even pixel Negative LVDS differential data input. Channel 0	(8)

29	ERX0+	Even pixel Positive LVDS differential data input. Channel 0	(8)
30	ERX1-	Even pixel Negative LVDS differential data input. Channel 1	
31	ERX1+	Even pixel Positive LVDS differential data input. Channel 1	
32	ERX2-	Even pixel Negative LVDS differential data input. Channel 2	
33	ERX2+	Even pixel Positive LVDS differential data input. Channel 2	
34	GND	Ground	
35	ECLK-	Even pixel Negative LVDS differential clock input.	(8)
36	ECLK+	Even pixel Positive LVDS differential clock input.	
37	GND	Ground	
38	ERX3-	Even pixel Negative LVDS differential data input. Channel 3	(8)
39	ERX3+	Even pixel Positive LVDS differential data input. Channel 3	
40	N.C.	No Connection	(1)
41	N.C.	No Connection	
42	N.C.	No Connection	
43	SCN_EN	Input signal for Scanning Enable	(5)(7)
44	GND	Ground	
45	GND	Ground	
46	GND	Ground	
47	N.C.	No Connection	(1)
48	VCC	+12V power supply	
49	VCC	+12V power supply	
50	VCC	+12V power supply	
51	VCC	+12V power supply	

Note (1) Reserved for internal use. Please leave it open.

Note (2) LVDS format selection.

L= Connect to GND, H=Connect to +3.3V or Open

SELLVDS	Note
L	JEIDA Format
H or Open	VESA Format

Note (3) 2D/3D mode selection.

L= Connect to GND or Open, H=Connect to +3.3V

2D/3D	Note
L or Open	2D Mode
H	3D Mode

Note (4) Input signal for Left Right eye frame synchronous

$V_{IL}=0\sim 0.8\text{ V}$, $V_{IH}=2.0\sim 3.3\text{ V}$

L/R	Note
L	Right synchronous signal
H	Left synchronous signal

Note (5) Scanning enable selection.

L= Connect to GND or Open, H=Connect to +3.3V

SCN_EN	Note
L or Open	Scanning Disable
H	Scanning Enable

Note (6) SELLVDS signal pin connected to the LCM side has the following diagram.

R1 in the system side should be less than 1K Ohm. ($R1 < 1K\text{ Ohm}$)

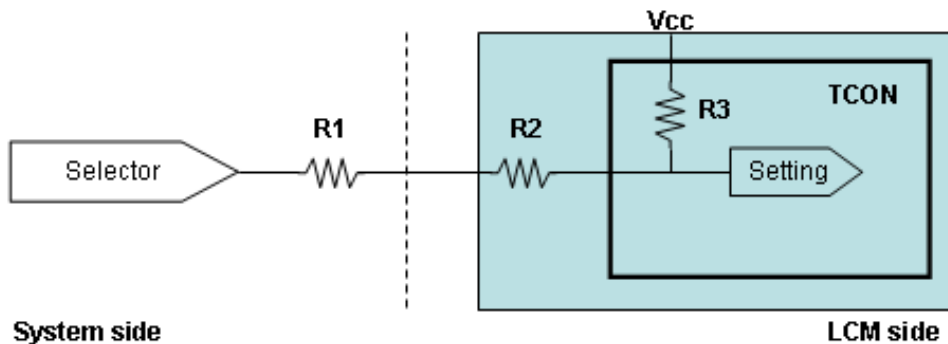

System side
 $R1 < 1K$

Note (7) 2D/3D, L/R, LD_EN and SCN_EN signal pin connected to the LCM side has the following diagram.

R1 in the system side should be less than 1K Ohm. ($R1 < 1K\text{ Ohm}$)

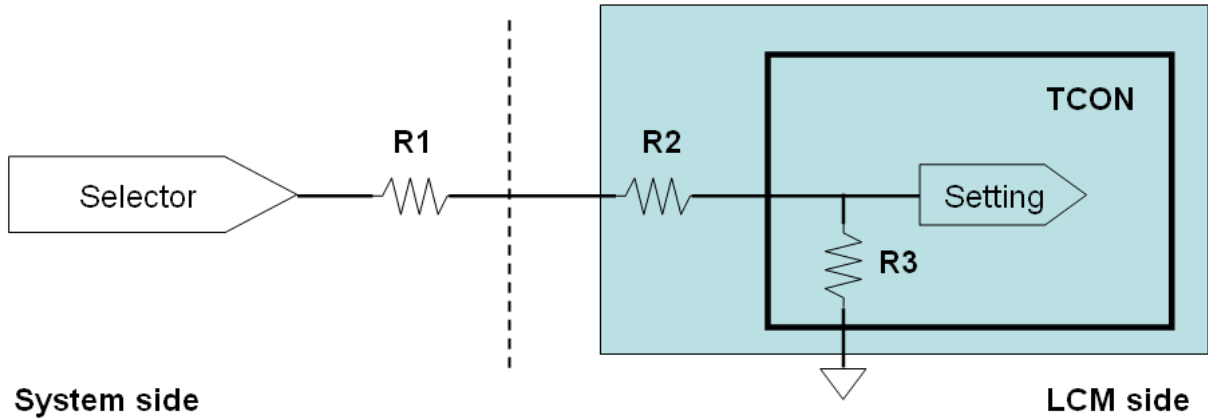

System side: $R1 < 1K$

Note (8) Two pixel data send into the module for every clock cycle. The first pixel of the frame is odd pixel and the second pixel is even pixel.

Note (9) The definition of L/R_O signal as follows

L= 0V , H= +3.3V

L/R_O	Note
L	Right glass turn on
H	Left glass turn on

Note (10) Please reference Appendix A

Line alternative format (1st line is left signal)

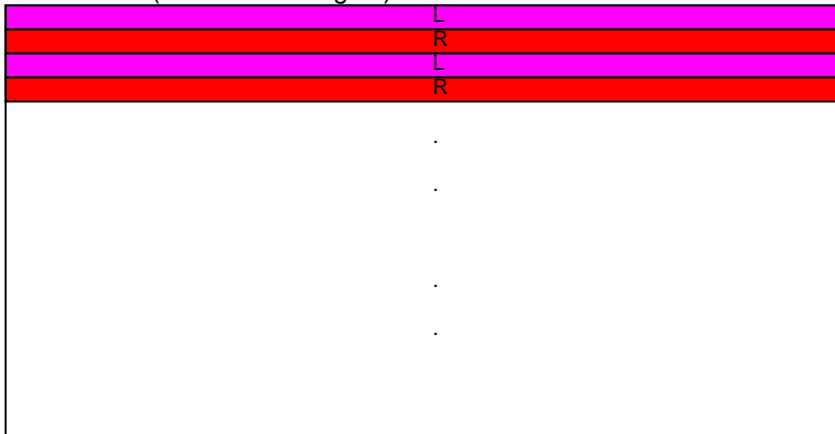

Note (11) The definition of PWM 0/1 signal as follows

L= 0V , H= +3.3V

PWM 0/1	Note
L	LED off
H	LED on

5.2 BLOCK DIAGRAM OF INTERFACE

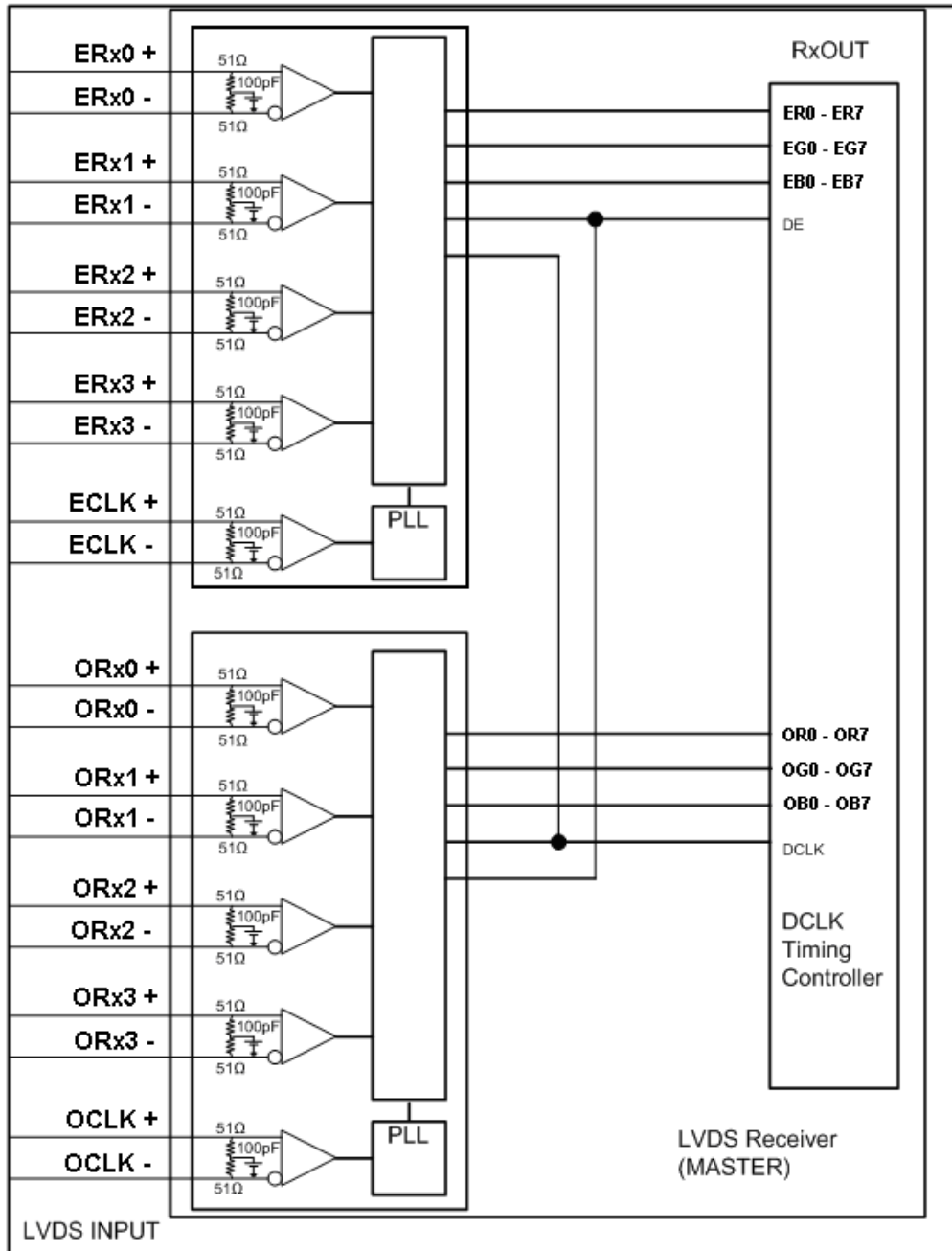

ER0~ER7	Even pixel R data	OR0~OR7	Odd pixel R data
EG0~EG7	Even pixel G data	OG0~OG7	Odd pixel G data
EB0~EB7	Even pixel B data	OB0~OB7	Odd pixel B data
		DE	Data enable signal
		DCLK	Data clock signal

5.3 LVDS INTERFACE

VESA Format : SELLVDS = H or Open

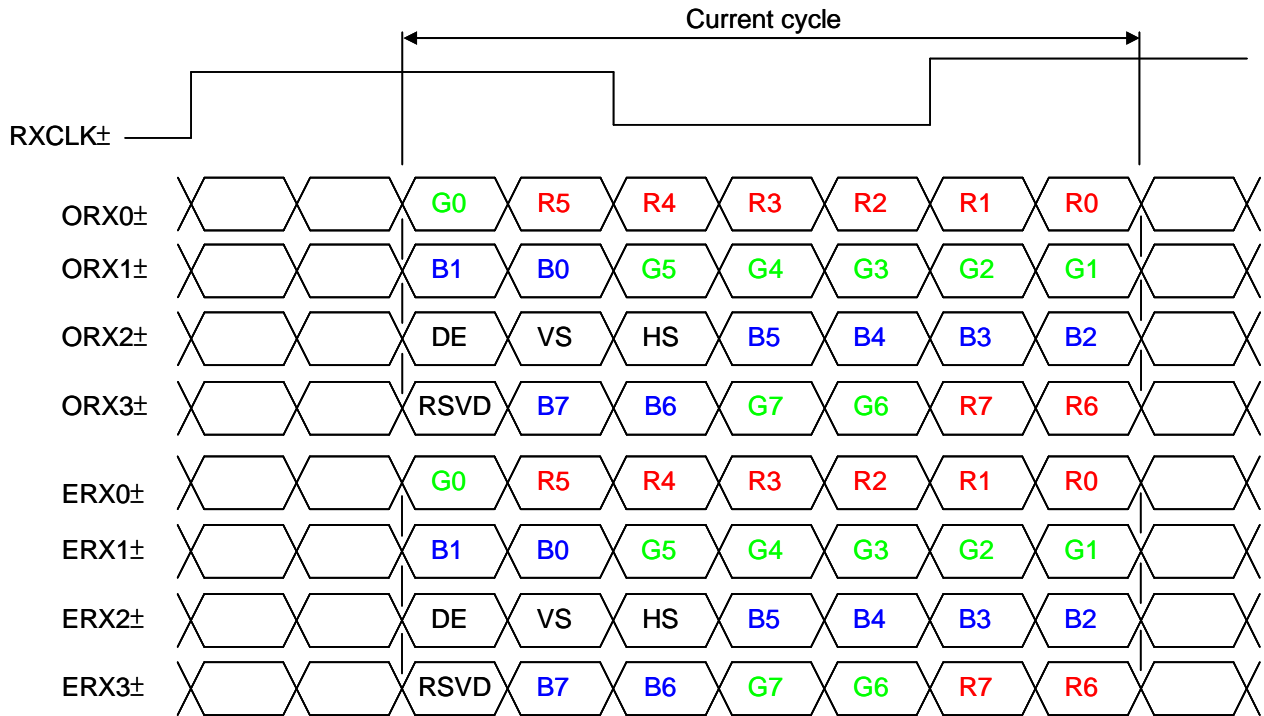

JEIDA Format : SELLVDS = L

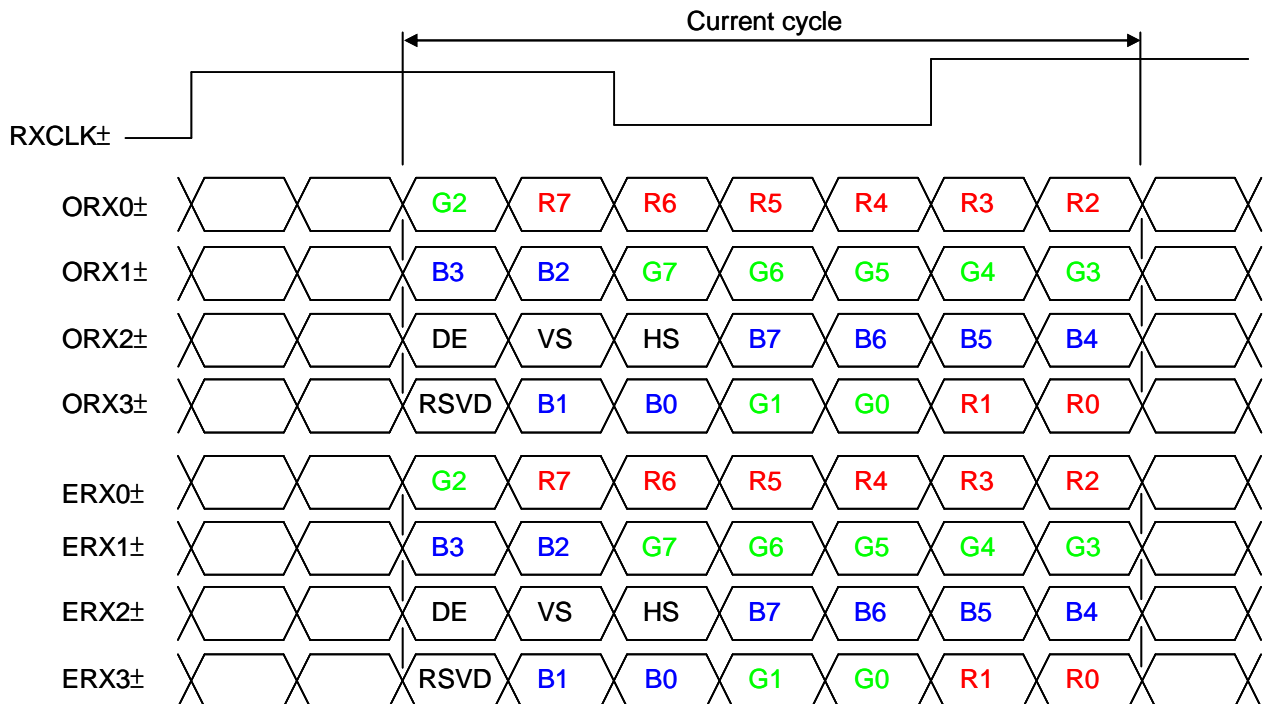

R0~R7: Pixel R Data (7; MSB, 0; LSB)

G0~G7: Pixel G Data (7; MSB, 0; LSB)

B0~B7: Pixel B Data (7; MSB, 0; LSB)

DE : Data enable signal

DCLK : Data clock signal

Notes (1) The system must have the transmitter to drive the module.

Notes (2) LVDS cable impedance shall be 50 ohms per signal line or about 100 ohms per twist-pair line when it is used differentially.

5.4 COLOR DATA INPUT ASSIGNMENT

The brightness of each primary color (red, green and blue) is based on the 8-bit gray scale data input for the color. The higher the binary input, the brighter the color. The table below provides the assignment of the color versus data input.

Color		Data Signal																							
		Red								Green								Blue							
		R7	R6	R5	R4	R3	R2	R1	R0	G7	G6	G5	G4	G3	G2	G1	G0	B7	B6	B5	B4	B3	B2	B1	B0
Basic Colors	Black	0	0	0	0	0	0	0	0	0	0	0	0	0	0	0	0	0	0	0	0	0	0	0	
	Red	1	1	1	1	1	1	1	1	0	0	0	0	0	0	0	0	0	0	0	0	0	0	0	
	Green	0	0	0	0	0	0	0	0	1	1	1	1	1	1	1	1	0	0	0	0	0	0	0	
	Blue	0	0	0	0	0	0	0	0	0	0	0	0	0	0	0	0	1	1	1	1	1	1	1	
	Cyan	0	0	0	0	0	0	0	0	1	1	1	1	1	1	1	1	1	1	1	1	1	1	1	
	Magenta	1	1	1	1	1	1	1	1	0	0	0	0	0	0	0	0	1	1	1	1	1	1	1	
	Yellow	1	1	1	1	1	1	1	1	1	1	1	1	1	1	1	1	0	0	0	0	0	0	0	
	White	1	1	1	1	1	1	1	1	1	1	1	1	1	1	1	1	1	1	1	1	1	1	1	
Gray Scale Of Red	Red (0) / Dark	0	0	0	0	0	0	0	0	0	0	0	0	0	0	0	0	0	0	0	0	0	0		
	Red (1)	0	0	0	0	0	0	0	1	0	0	0	0	0	0	0	0	0	0	0	0	0	0		
	Red (2)	0	0	0	0	0	0	1	0	0	0	0	0	0	0	0	0	0	0	0	0	0	0		
	:	:	:	:	:	:	:	:	:	:	:	:	:	:	:	:	:	:	:	:	:	:	:		
	:	:	:	:	:	:	:	:	:	:	:	:	:	:	:	:	:	:	:	:	:	:	:		
	Red (253)	1	1	1	1	1	1	0	1	0	0	0	0	0	0	0	0	0	0	0	0	0	0		
	Red (254)	1	1	1	1	1	1	1	0	0	0	0	0	0	0	0	0	0	0	0	0	0	0		
Red (255)	1	1	1	1	1	1	1	1	0	0	0	0	0	0	0	0	0	0	0	0	0	0			
Gray Scale Of Green	Green (0) / Dark	0	0	0	0	0	0	0	0	0	0	0	0	0	0	0	0	0	0	0	0	0	0		
	Green (1)	0	0	0	0	0	0	0	0	0	0	0	0	0	0	1	0	0	0	0	0	0	0		
	Green (2)	0	0	0	0	0	0	0	0	0	0	0	0	0	1	0	0	0	0	0	0	0	0		
	:	:	:	:	:	:	:	:	:	:	:	:	:	:	:	:	:	:	:	:	:	:	:		
	:	:	:	:	:	:	:	:	:	:	:	:	:	:	:	:	:	:	:	:	:	:	:		
	Green (253)	0	0	0	0	0	0	0	0	1	1	1	1	1	1	0	1	0	0	0	0	0	0		
	Green (254)	0	0	0	0	0	0	0	0	1	1	1	1	1	1	0	0	0	0	0	0	0	0		
Green (255)	0	0	0	0	0	0	0	0	1	1	1	1	1	1	1	0	0	0	0	0	0	0			

Gray Scale Of Blue	Blue (0) / Dark	0	0	0	0	0	0	0	0	0	0	0	0	0	0	0	0	0	0	0	0	0	0	0	0	0
	Blue (1)	0	0	0	0	0	0	0	0	0	0	0	0	0	0	0	0	0	0	0	0	0	0	0	0	1
	Blue (2)	0	0	0	0	0	0	0	0	0	0	0	0	0	0	0	0	0	0	0	0	0	0	1	0	0
	:	:	:	:	:	:	:	:	:	:	:	:	:	:	:	:	:	:	:	:	:	:	:	:	:	:
	:	:	:	:	:	:	:	:	:	:	:	:	:	:	:	:	:	:	:	:	:	:	:	:	:	:
	Blue (253)	0	0	0	0	0	0	0	0	0	0	0	0	0	0	0	0	1	1	1	1	1	1	1	0	1
	Blue (254)	0	0	0	0	0	0	0	0	0	0	0	0	0	0	0	0	1	1	1	1	1	1	1	1	0
Blue (255)	0	0	0	0	0	0	0	0	0	0	0	0	0	0	0	0	1	1	1	1	1	1	1	1	1	

Note (1) 0: Low Level Voltage, 1: High Level Voltage

5.5 FLICKER (Vcom) ADJUSTMENT

(1) Adjustment Pattern:

Column-inversion pattern was shown as below. If customer need below pattern, please directly contact with Account FAE.

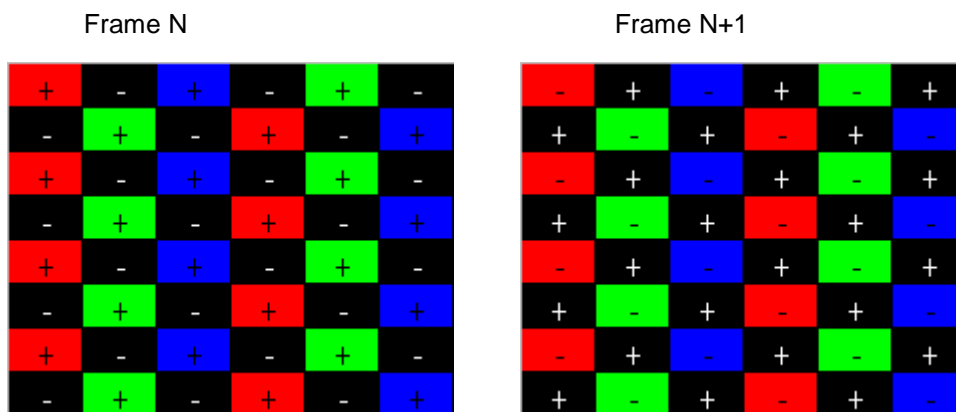

(2) Adjustment method: (VR)

Flicker should be adjusted by turning the volume for flicker adjustment by the ceramic driver. It is adjusted to the point with least flickering of the center screen. After making it surely overrun at once, it should be adjusted to the optimum point.

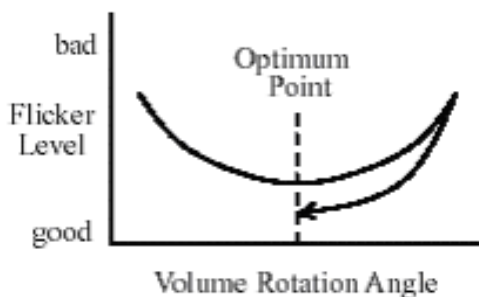

(3) Adjustment method: (Digital V-com)

Programmable memory IC is used for Digital V-com adjustment in this model. CMI provide Auto Vcom tools to adjust Digital V-com. The detail connection and setting instruction, please directly contact with Account FAE or refer CMI Auto V-com adjustment OI. Below items is suggested to be ready before Digital V-com adjustment in customer LCM line.

- a. USB Sensor Board.
- b. Programmable software.

6. INTERFACE TIMING

6.1 INPUT SIGNAL TIMING SPECIFICATIONS

(Ta = 25 ± 2 °C)

The input signal timing specifications are shown as the following table and timing diagram.

Signal	Item	Symbol	Min.	Typ.	Max.	Unit	Note
LVDS Receiver Clock	Frequency	$F_{clk_{in}}$ (=1/TC)	(60)	74.25	(77)	MHz	
	Input cycle to cycle jitter	T_{rcj}	-	-	200	ps	(3)
	Spread spectrum modulation range	$F_{clk_{in_mod}}$	$F_{clk_{in}}-2\%$	-	$F_{clk_{in}}+2\%$	MHz	(4)
	Spread spectrum modulation frequency	F_{SSM}	-	-	200	KHz	
LVDS Receiver Data	Setup Time	T_{lvsu}	600	-	-	ps	(5)
	Hold Time	T_{lvhd}	600	-	-	ps	

6.1.1 Timing spec for Frame Rate = 50Hz

Signal	Item	Symbol	Min.	Typ.	Max.	Unit	Note	
Frame rate	2D mode	F_{r5}	(47)	50	(53)	Hz		
	3D mode	F_{r5}	(50)	50	(50)	Hz	(7)	
Vertical Active Display Term	2D Mode	Total	T_v	(1115)	1125	(1380)	Th	$T_v=T_{vd}+T_{vb}$
		Display	T_{vd}	1080	1080	1080	Th	-
		Blank	T_{vb}	(35)	45	(300)	Th	-
	3D Mode	Total	T_v	(1350)				
		Display	T_{vd}	1080				
		Blank	T_{vb}	(270)				
Horizontal Active Display Term	2D Mode	Total	T_h	(1050)	1100	(1150)	T_c	$T_h=T_{hd}+T_{hb}$
		Display	T_{hd}	960	960	960	T_c	-
		Blank	T_{hb}	(90)	140	(190)	T_c	-
	3D Mode	Total	T_h	(1050)	1100	(1150)	T_c	$T_h=T_{hd}+T_{hb}$
		Display	T_{hd}	960	960	960	T_c	-
		Blank	T_{hb}	(90)	140	(190)	T_c	-

6.1.2 Timing spec for Frame Rate = 60Hz

Signal	Item	Symbol	Min.	Typ.	Max.	Unit	Note	
Frame rate	2D mode	F_{r6}	(57)	60	(62.5)	Hz		
	3D mode	F_{r6}	(60)	60	(60)	Hz	(7)	
Vertical Active Display Term	2D Mode	Total	T_v	(1115)	1125	(1380)	Th	$T_v = T_{vd} + T_{vb}$
		Display	T_{vd}	1080	1080	1080	Th	—
		Blank	T_{vb}	(35)	45	(300)	Th	—
	3D Mode	Total	T_v	(1125)			Th	(6)(8)
		Display	T_{vd}	1080			Th	
		Blank	T_{vb}	(45)			Th	
Horizontal Active Display Term	2D Mode	Total	T_h	(1050)	1100	(1150)	T_c	$T_h = T_{hd} + T_{hb}$
		Display	T_{hd}	960	960	960	T_c	—
		Blank	T_{hb}	(90)	140	(190)	T_c	—
	3D Mode	Total	T_h	(1050)	1100	(1150)	T_c	$T_h = T_{hd} + T_{hb}$
		Display	T_{hd}	960	960	960	T_c	—
		Blank	T_{hb}	(90)	140	(190)	T_c	—

Note (1) Please make sure the range of pixel clock has follow the below equation :

$$F_{clk(in)(max)} \geq F_{r6} \times T_v \times T_h$$

$$F_{r5} \times T_v \times T_h \geq F_{clk(in)(min)}$$

Note (2) This module is operated in DE only mode and please follow the input signal timing diagram below :

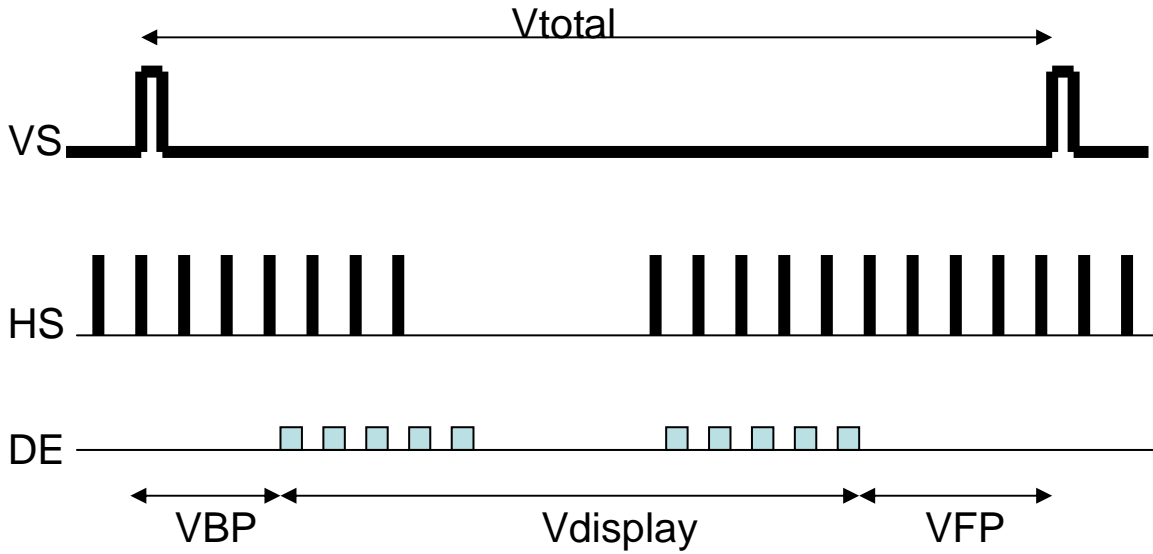

- VBP max : 150 line

Suggest $VBP = VFP = \frac{1}{2} * (V_{total} - V_{display})$

INPUT SIGNAL TIMING DIAGRAM

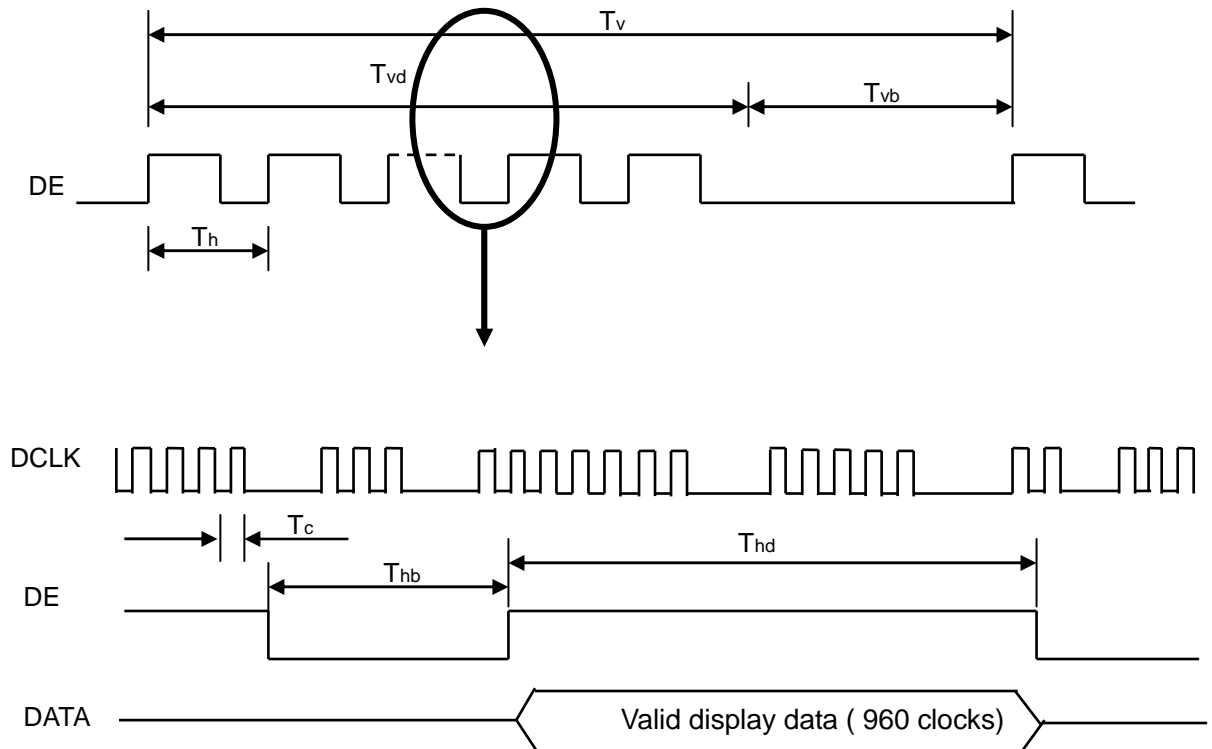

Note (3) The input clock cycle-to-cycle jitter is defined as below figures. $Trcl = |T_1 - T_1|$

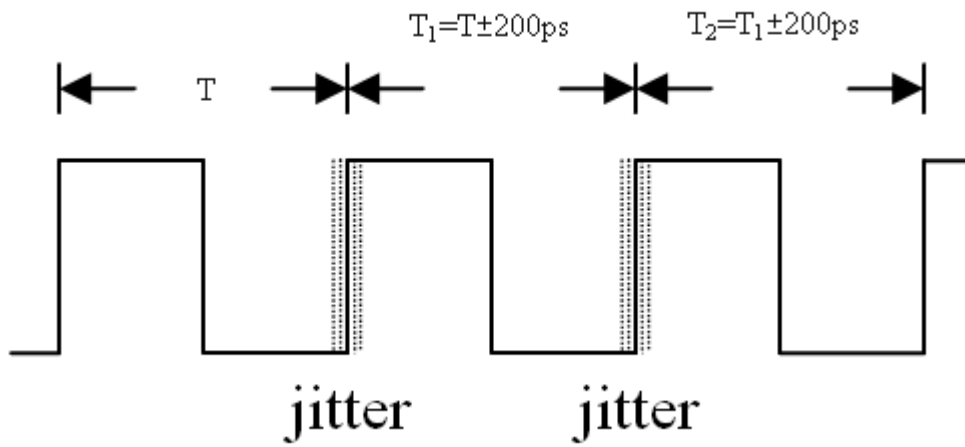

Note (4) The SSCG (Spread spectrum clock generator) is defined as below figures.

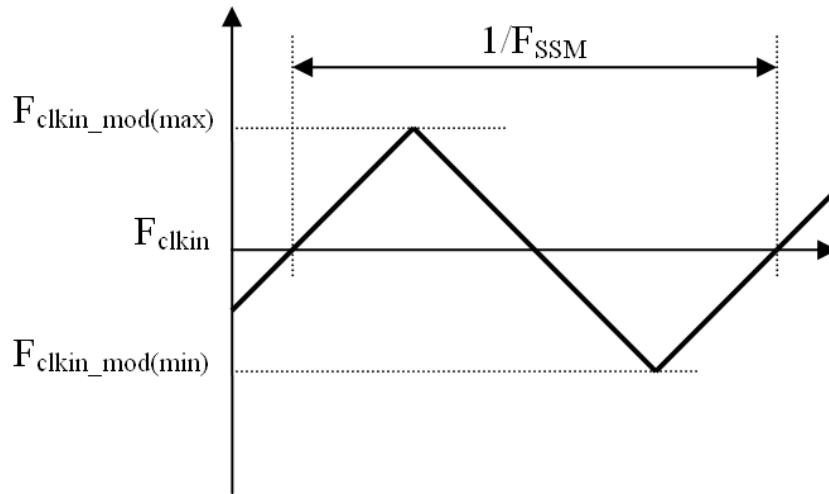

Note (5) The LVDS timing diagram and setup/hold time is defined and showing as the following figures.

LVDS RECEIVER INTERFACE TIMING DIAGRAM

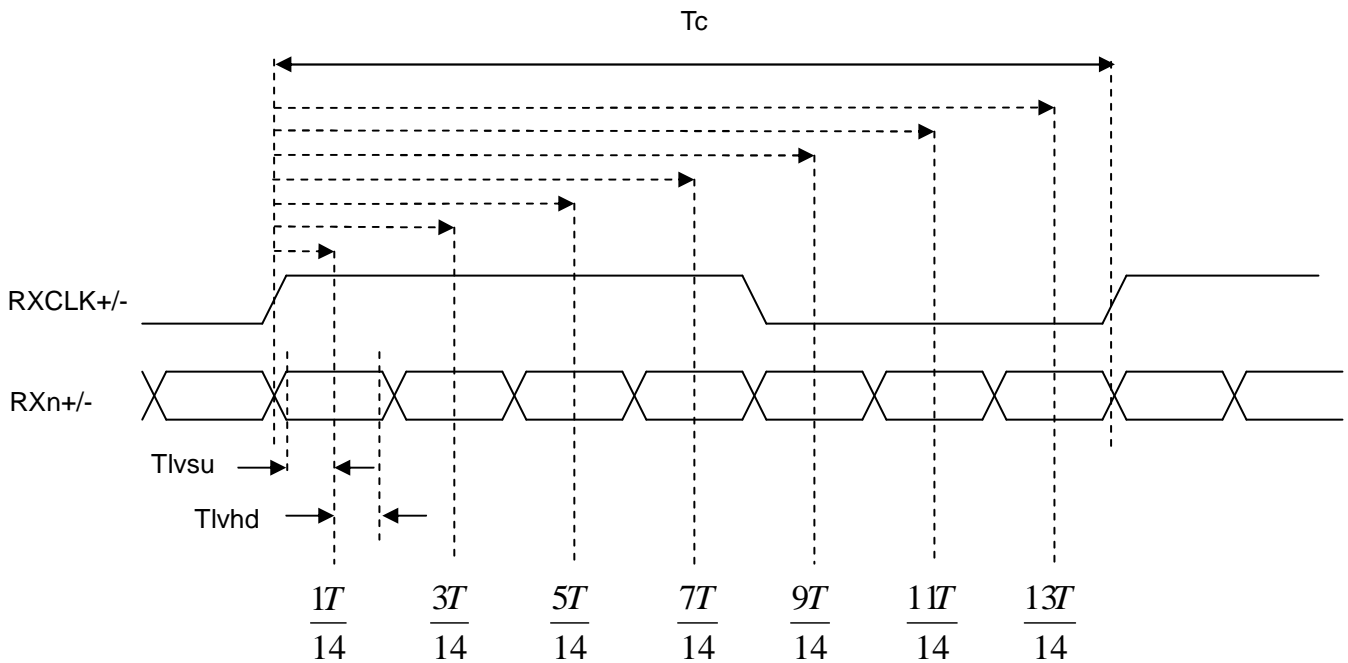

Note (6) Please fix the Vertical timing (Vertical Total =1350 / Display =1080 / Blank = 270) in 100Hz 3D mode and Vertical timing (Vertical Total =1125 / Display =1080 / Blank = 45) in 120Hz 3D mode

Note (7) In 3D mode, the set up Fr5 and Fr6 in Typ. ± 3 HZ .In order to ensure that the electric function performance to avoid no display symptom.(Except picture quality symptom.)

Note (8) In 3D mode, the set up Tv and Tvb in Typ. ± 30 .In order to ensure that the electric function performance to avoid no display symptom.(Except picture quality symptom.)

6.2 POWER ON/OFF SEQUENCE (Ta = 25 ± 2 °C)

6.2.1 POWER ON/OFF SEQUENCE

To prevent a latch-up or DC operation of LCD module, the power on/off sequence should be as the diagram below.

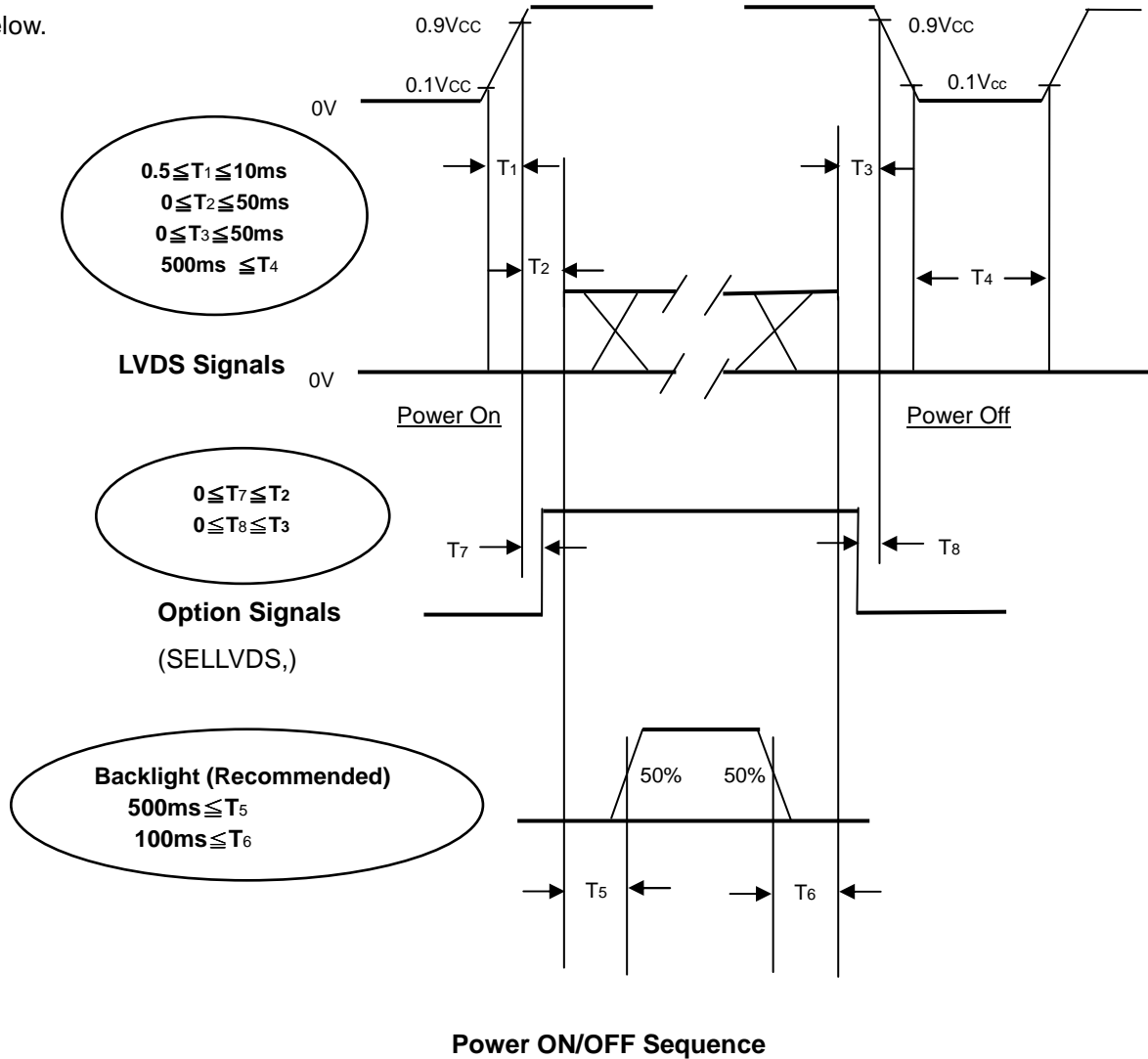

6.2.2 2D/3D MODE CHANGE SIGNAL SEQUENCE WITHOUT VCC TURN OFF AND TURN ON

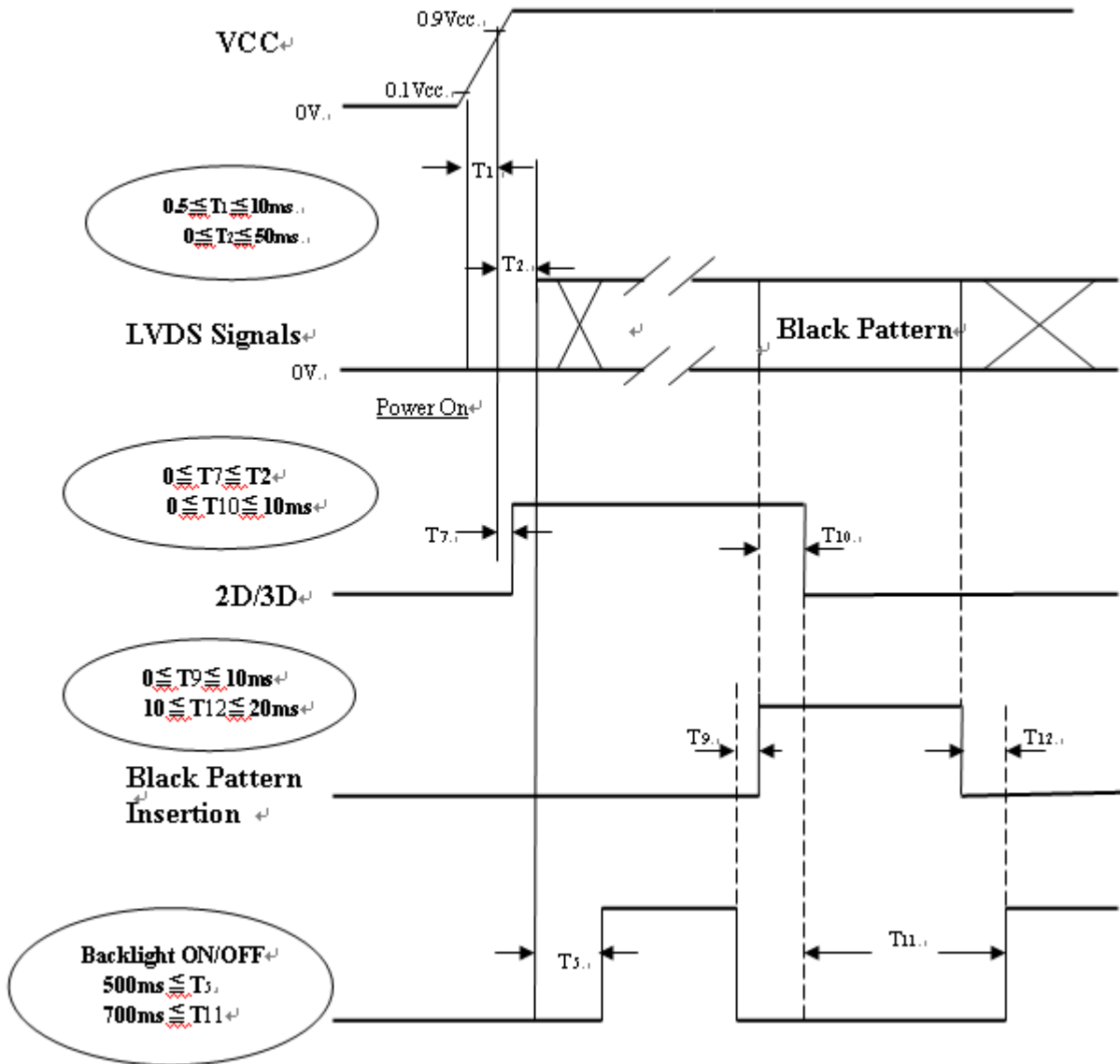

Note (1) The supply voltage of the external system for the module input should follow the definition of Vcc.

Note (2) Apply the lamp voltage within the LCD operation range. When the backlight turns on before the LCD operation or the LCD turns off before the backlight turns off, the display may momentarily become abnormal screen.

Note (3) In case of VCC is in off level, please keep the level of input signals on the low or high impedance.

If $T_2 < 0$, that maybe cause electrical overstress failure.

Note (4) T_4 should be measured after the module has been fully discharged between power off and on period.

Note (5) Interface signal shall not be kept at high impedance when the power is on.

Note (6) When 2D/3D mode is changed, TCON will insert black pattern internally. During black insertion, TCON

would load required optical table and TCON parameter setting. The black insertion time should be longer than 650ms because TCON must recognize 2D or 3D format and set the correct parameter.

Note (7) 2D/3D switching time should be larger than 500ms.

7. OPTICAL CHARACTERISTICS

7.1 TEST CONDITIONS

Item	Symbol	Value	Unit
Ambient Temperature	Ta	25±2	Oc
Ambient Humidity	Ha	50±10	%RH
Supply Voltage	VCC	12±1.2	V
Input Signal	According to typical value in "3. ELECTRICAL CHARACTERISTICS"		
LED Current	I _L	170	mA
Oscillating Frequency (Inverter)	F _w	40 ± 3	KHz
Vertical Frame Rate	Fr	60	Hz

Local Dimming Function should be Disable before testing to get the steady optical characteristics (According to 5.1 CNF1 Connector Pin Assignment)

The LCD module should be stabilized at given temperature for 1 hour to avoid abrupt temperature change during measuring in a windless room.

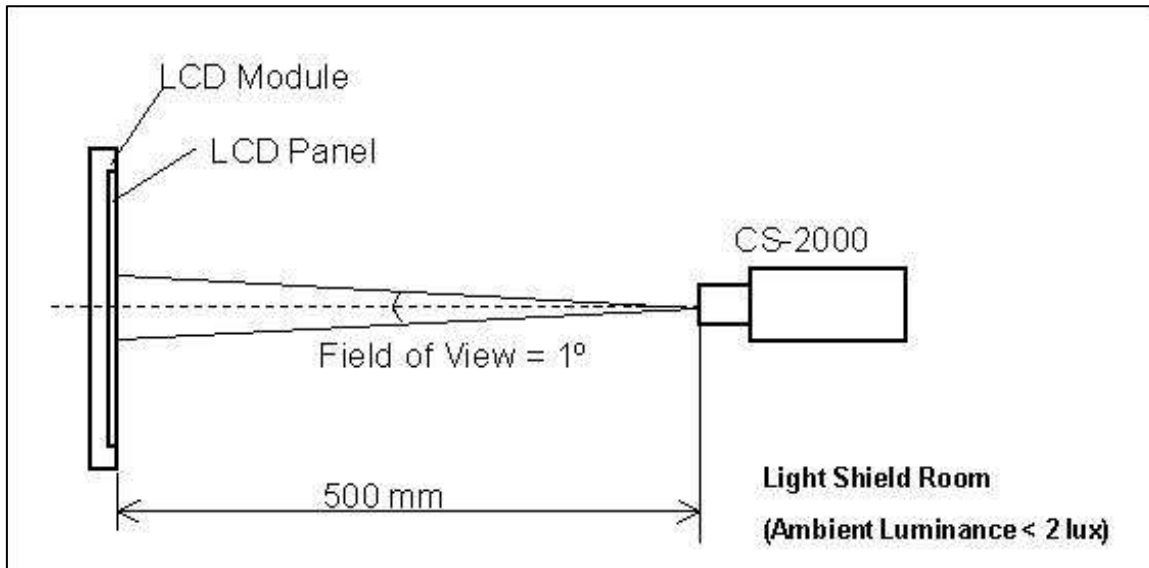

7.2 OPTICAL SPECIFICATIONS

The relative measurement methods of optical characteristics are shown as below. The following items should be measured under the test conditions described in 7.1 and stable environment shown in 7.1.

Item	Symbol	Condition	Min.	Typ.	Max.	Unit	Note
Color Chromaticity	Red	Rcx	Viewing Angle at Normal Direction Standard light source "C"	Typ. -0.03	0.661	Typ. +0.03	-
		Rcy			0.322		-
	Green	Gcx			0.261		-
		Gcy			0.579		-
	Blue	Bcx			0.135		-
		Bcy			0.095		-
	White	Wcx			0.293		-
		Wcy			0.339		-
Center Transmittance	T%	$\theta_x=0^\circ, \theta_y=0^\circ$	-	TBD		%	(1),(6)
Contrast Ratio	CR	with CMI module	3500	5000		-	(1),(3)
Response Time	Gray to gray	$\theta_x=0^\circ, \theta_y=0^\circ$ with CMI Module	-	6.5	13	ms	(1),(4)
White Variation	δW	$\theta_x=0^\circ, \theta_y=0^\circ$ with CMI module	-	-	1.3	-	(1),(5)
Viewing Angle	Horizontal	θ_{x+}	-	88	-	Deg.	(1),(2)
		θ_{x-}	-	88	-		
	Vertical	θ_{y+}	-	88	-		
		θ_{y-}	-	88	-		
Transmission direction of the up polarizer	Φ_{up-P}	-	-	135	-	Deg.	(7)

Note (0) Light source is the standard light source "C" which is defined by CIE and driving voltage are based on suitable gamma voltages. The calculating method is as following:

1. Measure Module's and BLU's spectrum at center point. White and R,G,B are with signal input. BLU (for V500HK1-LD1) is supplied by CMI.
2. Calculate cell's spectrum.
3. Calculate cell's chromaticity by using the spectrum of standard light source "C".

Note (1) Light source is the BLU which supplied by CMI and driving voltage are based on suitable gamma voltages.

Note (2) Definition of Viewing Angle (θ_x, θ_y):

Viewing angles are measured by Autronic Conoscope Cono-80 (or Eldim EZ-Contrast 160R)

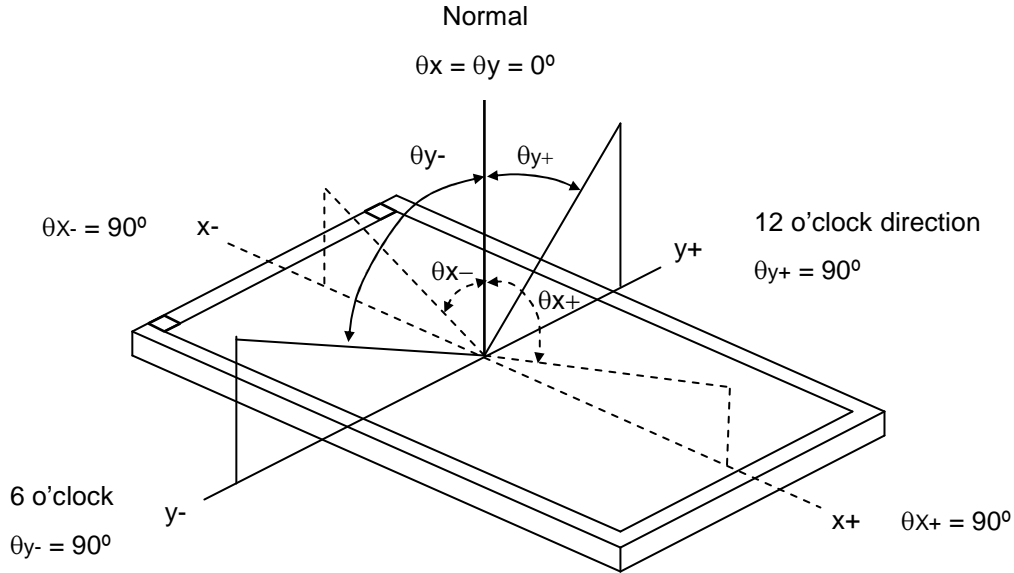

Note (3) Definition of Contrast Ratio (CR):

The contrast ratio can be calculated by the following expression.

$$\text{Contrast Ratio (CR)} = \frac{\text{Surface Luminance of L255}}{\text{Surface Luminance of L0}}$$

L255: Luminance of gray level 255

L 0: Luminance of gray level 0

CR = CR (X), where CR (X) is corresponding to the Contrast Ratio of the point X at the figure in Note (5).

Note (4) Definition of Gray-to-Gray Switching Time:

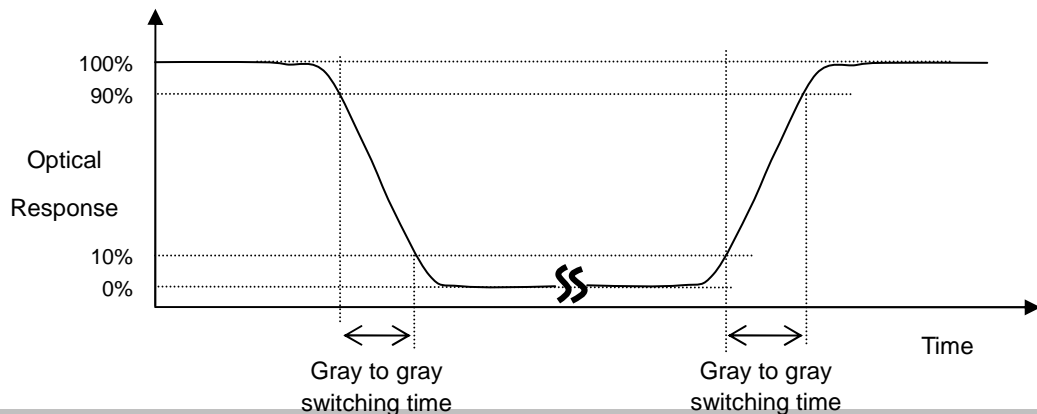

The driving signal means the signal of gray level 0, 124, 252, 380, 508, 636, 764, 892 and 1023.

Gray to gray average time means the average switching time of gray level 0, 124, 252, 380, 508, 636, 764, 892 and 1023 to each other.

Note (5) Definition of White Variation (δW):

Measure the luminance of gray level 255 at 5 points

$$\delta W = \text{Maximum [L (1), L (2), L (3), L (4), L (5)]} / \text{Minimum [L (1), L (2), L (3), L (4), L (5)]}$$

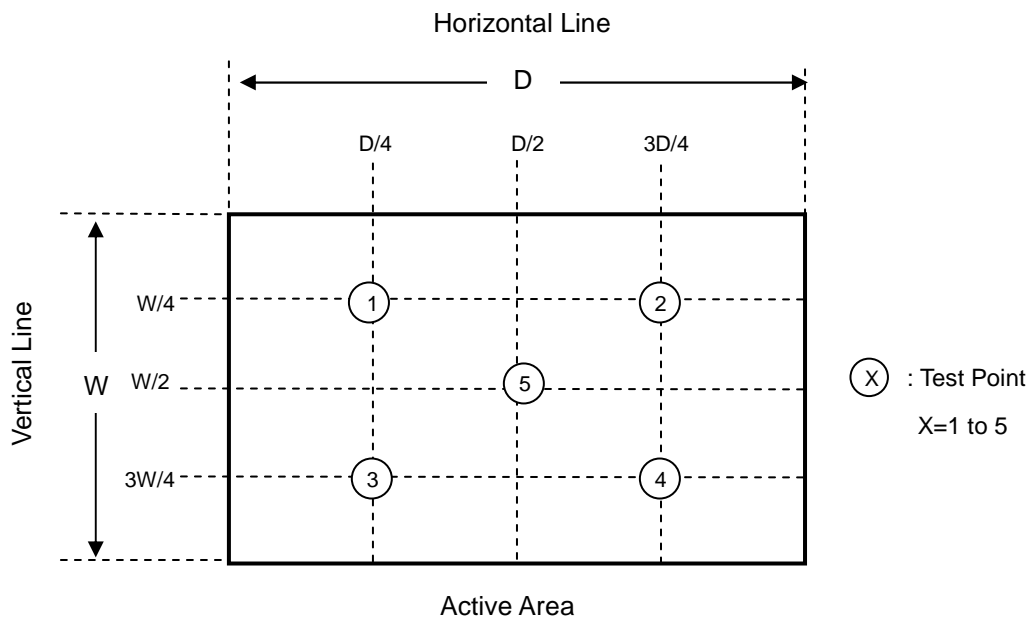

Note (6) Definition of Transmittance (T%) : (VA case)

Measure the luminance of gray level 255 at 5 points of LCD module.

$$\text{Transmittance (T\%)} = \frac{\text{average [L (1), L (2), L (3), L (4), L (5)] of LCD module}}{\text{average [L (1), L (2), L (3), L (4), L (5)] of backligh unit}} \times 100\%$$

The 5 point is corresponding of the point X at the figure in Note (5).

Note (7) This is a reference for designing the shutter glasses of 3D application. (VA case)

Definition of the transmission direction of the up polarizer(Φ_{up-P}) on LCD Module:

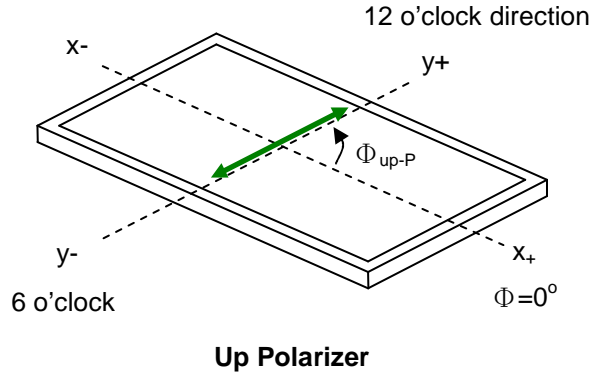

The transmission axis of the front polarizer of the shutter glasses should be parallel to this panel transmission direction to get a maximum 3D mode luminance.

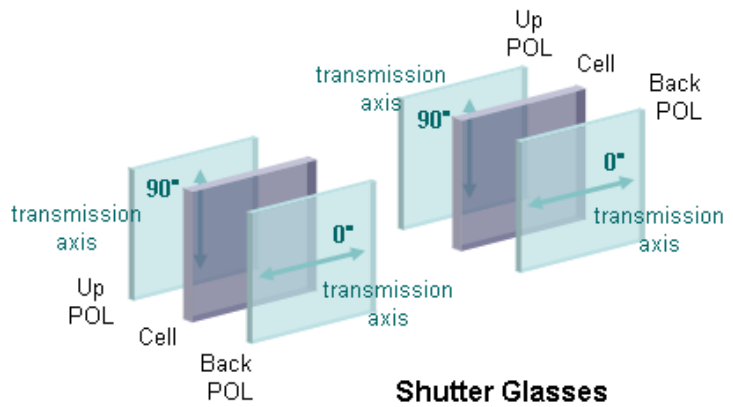
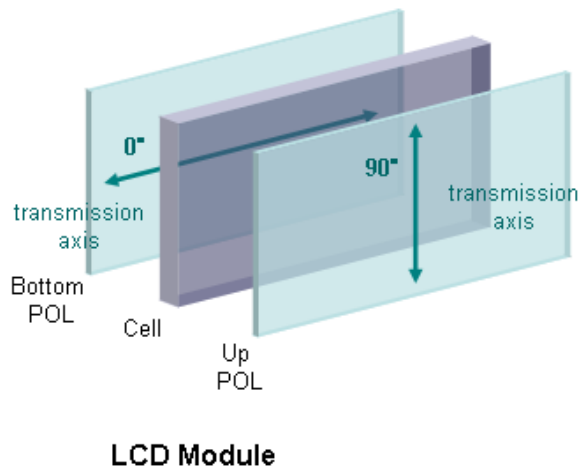

8. PRECAUTIONS

8.1 ASSEMBLY AND HANDLING PRECAUTIONS

- [1] Do not apply rough force such as bending or twisting to the module during assembly.
- [2] It is recommended to assemble or to install a module into the user's system in clean working areas. The dust and oil may cause electrical short or worsen the polarizer.
- [3] Do not apply pressure or impulse to the module to prevent the damage of LCD panel and Backlight.
- [4] Always follow the correct power-on sequence when the LCD module is turned on. This can prevent the damage and latch-up of the CMOS LSI chips.
- [5] Do not plug in or pull out the I/F connector while the module is in operation.
- [6] Do not disassemble the module.
- [7] Use a soft dry cloth without chemicals for cleaning, because the surface of polarizer is very soft and easily scratched.
- [8] Moisture can easily penetrate into LCD module and may cause the damage during operation.
- [9] When storing modules as spares for a long time, the following precaution is necessary.
 - [9.1] Do not leave the module in high temperature, and high humidity for a long time. It is highly recommended to store the module with temperature from 0 to 35°C at normal humidity without condensation.
 - [9.2] The module shall be stored in dark place. Do not store the TFT-LCD module in direct sunlight or fluorescent light.
- [10] When ambient temperature is lower than 10°C, the display quality might be reduced. For example, the response time will become slow, and the starting voltage of CCFL will be higher than that of room temperature.

8.2 SAFETY PRECAUTIONS

- [1] The startup voltage of a Backlight is approximately 1000 Volts. It may cause an electrical shock while assembling with the inverter. Do not disassemble the module or insert anything into the Backlight unit.
- [2] If the liquid crystal material leaks from the panel, it should be kept away from the eyes or mouth. In case of contact with hands, skin or clothes, it has to be washed away thoroughly with soap.
- [3] After the module's end of life, it is not harmful in case of normal operation and storage.

9. DEFINITION OF LABELS

9.1 OPEN CELL LABEL

The barcode nameplate is pasted on each open cell as illustration for CMI internal control.

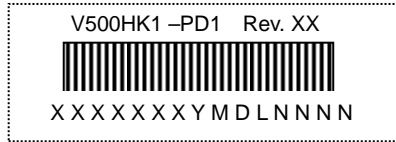
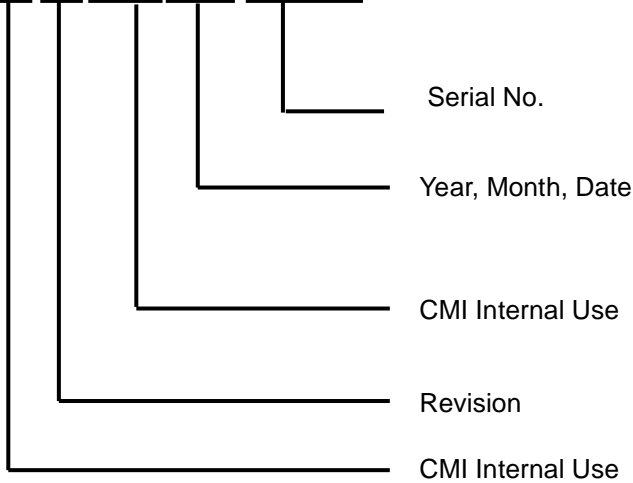

Figure.8-1 Serial No. Label on SPWB

Model Name: V500HK1-PD1

Revision: Rev. XX, for example: A0, A1... B1, B2... or C1, C2...etc.

Serial ID: XXXXXXXYMDLNNNN



Serial ID includes the information as below:

Manufactured Date:

Year: 2010=0, 2011=1,2012=2...etc.

Month: 1~9, A~C, for Jan. ~ Dec.

Day: 1~9, A~Y, for 1st to 31st, exclude I ,O, and U.

Revision Code: Cover all the change

Serial No.: Manufacturing sequence of product



Figure.9-2 Panel ID Label on Cell

Panel ID Label includes the information as below:

Panel ID: T X X X X X X X X X X

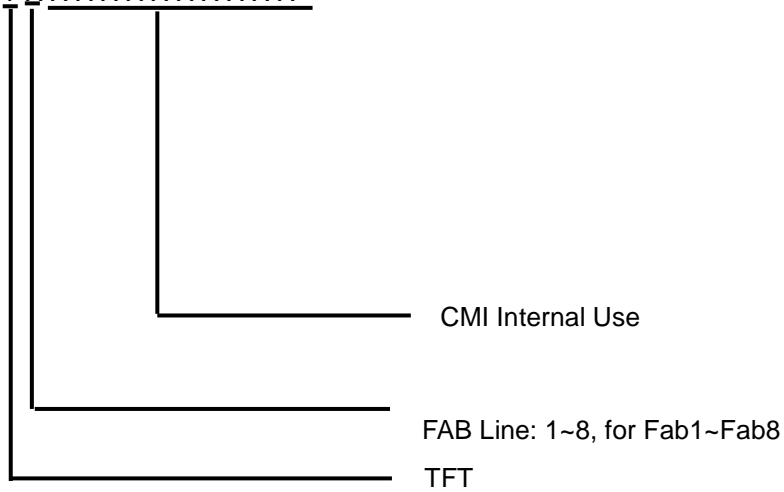

9.2 CARTON LABEL

The barcode nameplate is pasted on each box as illustration, and its definitions are as following explanation.

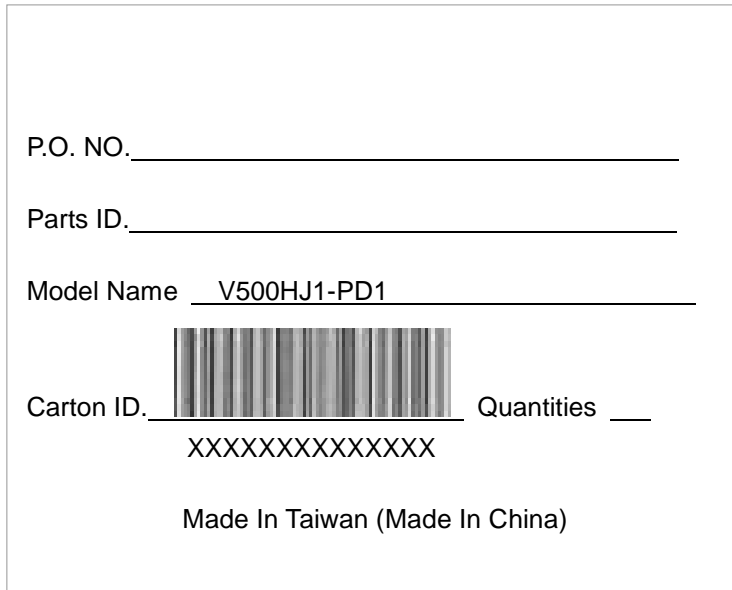

(a) Model Name: V500HK1- PD1

(b) Carton ID: X X X X X X Y M D X X X X

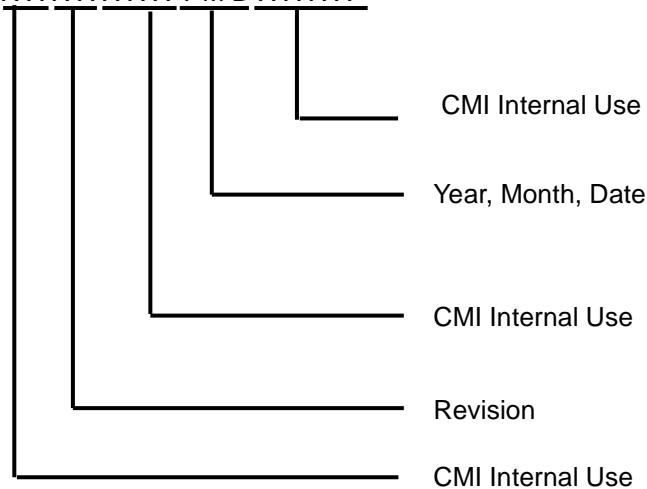

Serial ID includes the information as below:

Manufactured Date:

Year: 2010=0, 2011=1,2012=2...etc.

Month: 1~9, A~C, for Jan. ~ Dec.

Day: 1~9, A~Y, for 1st to 31st, exclude I ,O, and U.

Revision Code: Cover all the change

(c) Quantities: 8

10. Packaging

10.1 PACKING SPECIFICATIONS

- (1) 8 LCD TV Panels / 1 Box
- (2) Box dimensions : 1320 (L) X910 (W) X99 (H)mm
- (3) Weight : approximately 38 Kg (8 panels per box)
- (4) 80 LCD TV Panels / 1 Group

10.2 PACKING METHOD

Figures 9-1 and 9-2 are the packing method

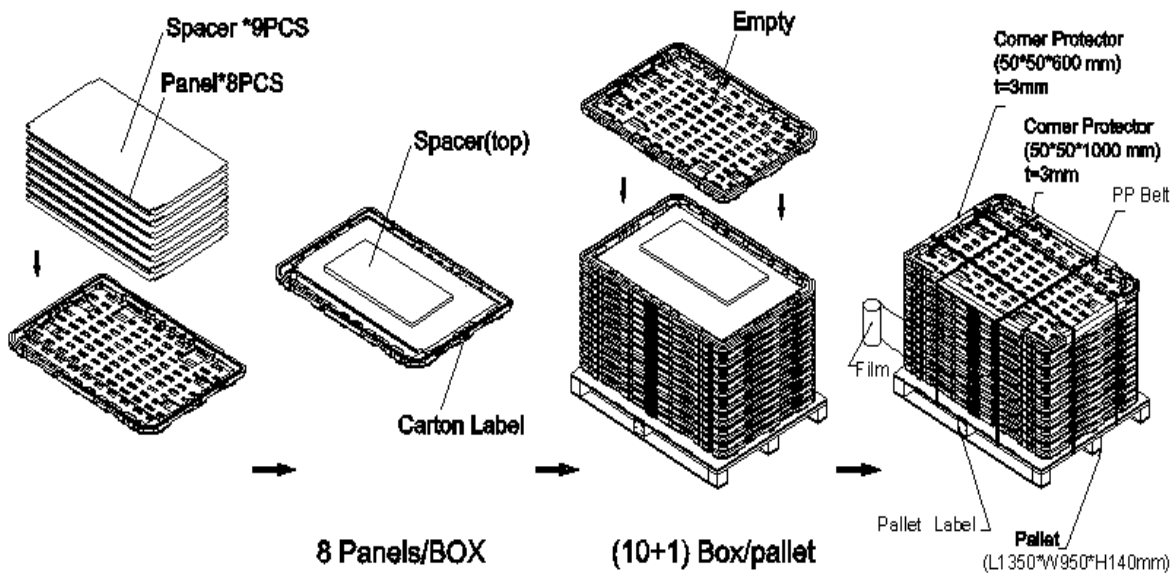
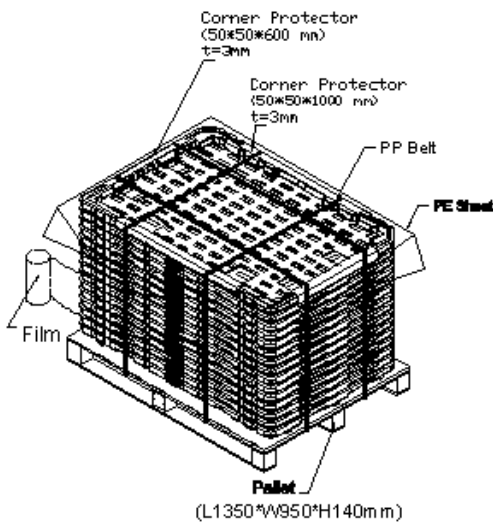

Figure.10-1 packing method

Sea / Land Transportation

Air Transportation



(10+1) Box/pallet

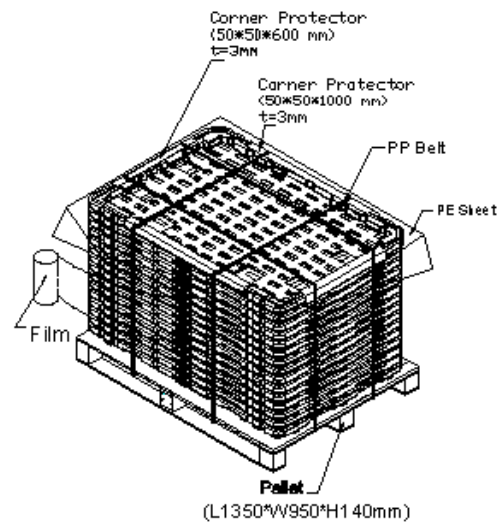

(10+1) Box/pallet

Figure.10-2 packing method

11. MECHANICAL CHARACTERISTIC

