

- Tentative Specification
 Preliminary Specification
 Approval Specification

MODEL NO.: V546H1
SUFFIX: PH5

Customer:	
APPROVED BY	SIGNATURE
Name / Title _____	_____
Note	
<hr/> Please return 1 copy for your confirmation with your signature and comments.	

Approved By	Checked By	Prepared By
Chao-Chun Chung	Ken Wu	Wei-ting Hsu

CONTENTS

1. GENERAL DESCRIPTION	4
1.1 OVERVIEW	4
1.2 FEATURES	4
1.3 MECHANICAL SPECIFICATIONS	4
2. ABSOLUTE MAXIMUM RATINGS	5
2.1 ABSOLUTE RATINGS OF ENVIRONMENT (BASE ON GMI MODULE V546H1-LH1)	5
2.2 PACKAGE STORAGE	6
3. ELECTRICAL CHARACTERISTICS	7
4. BLOCK DIAGRAM OF INTERFACE	9
4.1 TFT LCD MODULE	9
6. INTERFACE TIMING	14
6.1 INPUT SIGNAL TIMING SPECIFICATIONS	14
7. OPTICAL CHARACTERISTICS	18
7.1 TEST CONDITIONS	18
7.2 OPTICAL SPECIFICATIONS	18
8. PRECAUTIONS	21
8.1 ASSEMBLY AND HANDLING PRECAUTIONS	21
8.2 SAFETY PRECAUTIONS	21
9. DEFINITION OF LABELS	22
9.1 OPEN CELL LABEL	22
9.2 CARTON LABEL	22
10. PACKAGING	23
10.1 PACKAGING SPECIFICATIONS	23
10.2 PACKAGING METHOD	23
11. MECHANICAL CHARACTERISTICS	25

REVISION HISTORY

Version	Date	Page(New)	Section	Description

1. GENERAL DESCRIPTION

1.1 OVERVIEW

V546H1-PH5 is a 54.6" TFT Liquid Crystal Display cell with driver ICs and 2ch-LVDS interface. This product supports 1920 x 1080 Full HDTV format and can display 1.073G colors (10-bit/color). The backlight unit is not built-in.

1.2 FEATURES

CHARACTERISTICS ITEMS	SPECIFICATIONS
Screen Diagonal [in]	54.6
Pixels [lines]	1920 × 1080
Active Area [mm]	1209.6(H) x 680.4(V) (54.6" diagonal)
Sub-Pixel Pitch [mm]	0.21(H) x 0.63(V)
Pixel Arrangement	RGB vertical stripe
Weight [g]	3392
Physical Size [mm]	1251.4(W) x 737(H) x 1.75(D) Typ
Display Mode	Transmissive mode / Normally black
Contrast Ratio	4000:1 Typ. (Typical value measured at CMI's module)
Glass thickness (Array / CF) [mm]	0.7 / 0.7
Viewing Angle (CR>20)	+88/-88(H),+88/-88(V) Typ. (Typical value measured at CMI's module)
Color Chromaticity	R=(0.655, 0.326) G=(0.299, 0.599) B=(0.147, 0.099) W=(0.333, 0.372) (Light source is the standard light source "C" which is defined by CIE and driving voltages are based on suitable gamma voltages.)
Cell Transparency [%]	5.3%Typ. (Typical value measured at CMI's module)
Polarizer Surface Treatment	Super Clear Hardness (3H)

1.3 MECHANICAL SPECIFICATIONS

Item	Min.	Typ.	Max.	Unit	Note
Weight	-	3392	-	g	-
I/F connector mounting position	The mounting inclination of the connector makes the screen center within ± 0.5 mm as the horizontal.				(2)

Note (1) Please refer to the attached drawings for more information of front and back outline dimensions.

Note (2) Connector mounting position

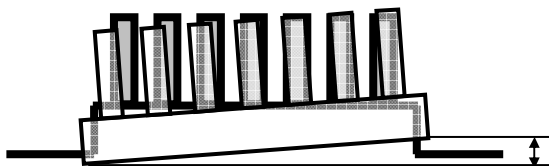

2. ABSOLUTE MAXIMUM RATINGS

2.1 ABSOLUTE RATINGS OF ENVIRONMENT (BASE ON CMI MODULE V546H1-LH1)

Item	Symbol	Value		Unit	Note
		Min.	Max.		
Storage Temperature	TST	-20	+60	°C	(1)
Operating Ambient Temperature	TOP	0	50	°C	(1), (2)
Shock (Non-Operating)	SNOP	-	30	G	(3), (5)
Vibration (Non-Operating)	VNOP	-	1.0	G	(4), (5)

Note (1) Temperature and relative humidity range is shown in the figure below.

(a) 90 %RH Max. ($T_a \leq 40$ °C).

(b) Wet-bulb temperature should be 39 °C Max. ($T_a > 40$ °C).

(c) No condensation.

Note (2) The maximum operating temperature is based on the test condition that the surface temperature of display area is less than or equal to 65 °C with LCD module alone in a temperature controlled chamber. Thermal management should be considered in final product design to prevent the surface temperature of display area from being over 65 °C. The range of operating temperature may degrade in case of improper thermal management in final product design.

Note (3) 11 ms, half sine wave, 1 time for $\pm X$, $\pm Y$, $\pm Z$.

Note (4) 10 ~ 200 Hz, 10 min, 1 time each X, Y, Z.

Note (5) At testing Vibration and Shock, the fixture in holding the module has to be hard and rigid enough so that the module would not be twisted or bent by the fixture.

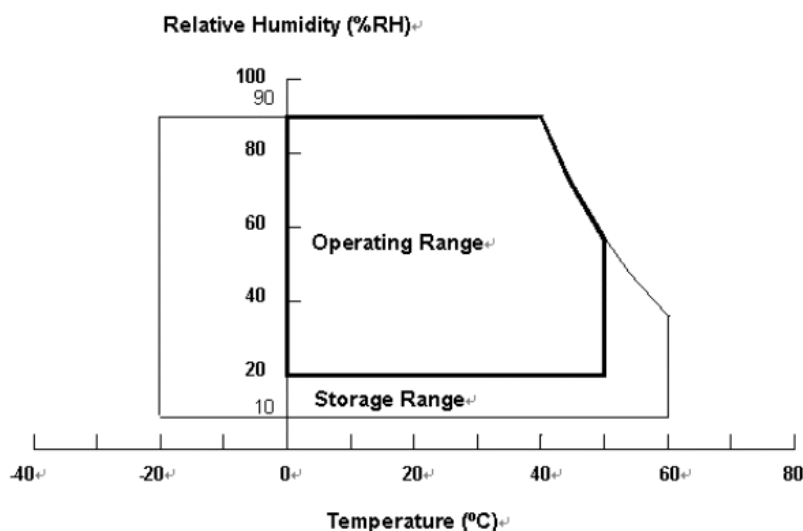

2.2 PACKAGE STORAGE

Storage condition: With shipping package.

Storage temperature rang: $25\pm 5^{\circ}\text{C}$

Storage humidity range: $50\pm 10\%\text{RH}$

Shelf life: a month

3. ELECTRICAL CHARACTERISTICS
3.1 TFT LCD MODULE (Ta = 25 ± 2 °C)

Parameter		Symbol	Value			Unit	Note
			Min.	Typ.	Max.		
Power Supply Voltage		V _{CC}	10.8	12	13.2	V	(1)
Rush Current		I _{RUSH}	-	-	5.2	A	(2)
Power Supply Current	White	I _{CC}	-	1.7	-	A	(3)
	Black		-	1.7	-	A	
	Vertical Stripe		-	2.6	3.1	A	
LVDS Interface	Common Input Voltage	V _{LVC}	1.125	1.25	1.375	V	
	Terminating Resistor	R _T	-	100	-	ohm	
CMIS interface	Input High Threshold Voltage	V _{IH}	2.7	-	3.3	V	
	Input Low Threshold Voltage	V _{IL}	0	-	0.7	V	

Note (1) The module should be always operated within the above ranges.

Note (2) Measurement condition:

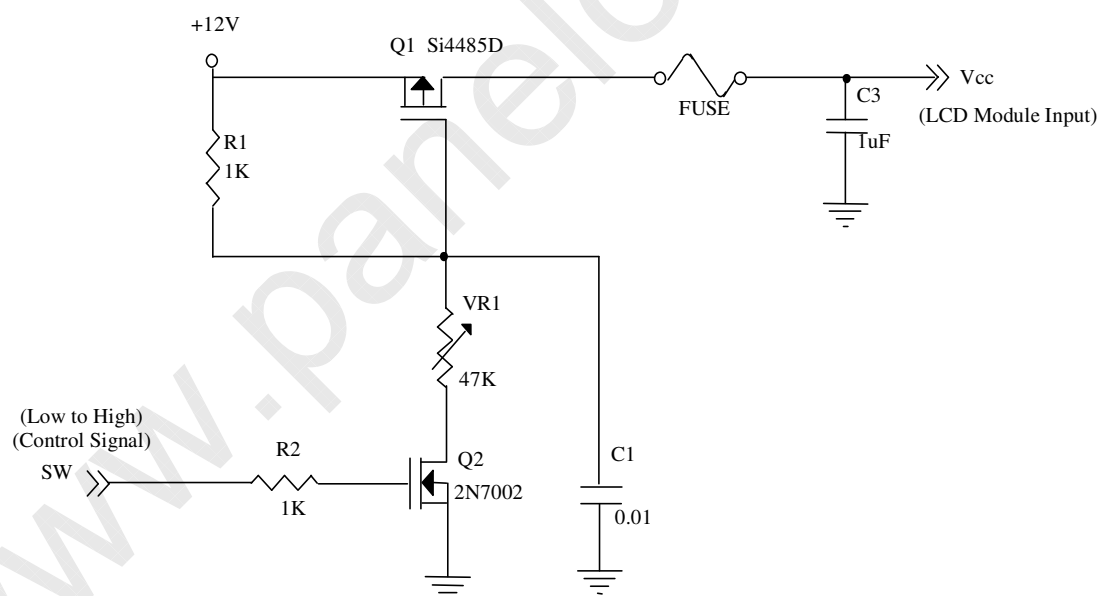

Vcc rising time is 470us

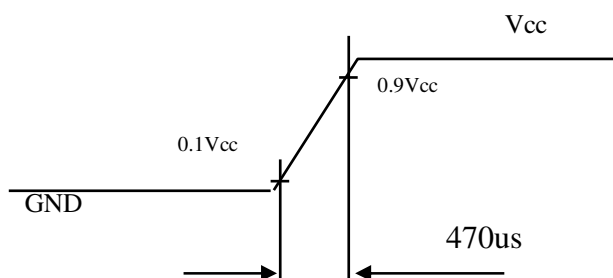

Note (3) The specified power supply current is under the conditions at $V_{cc} = 12V$, $T_a = 25 \pm 2^\circ C$, $f_v = 60Hz$, whereas a power dissipation check pattern below is displayed.

a. White Pattern



Active Area

b. Black Pattern



Active Area

c. Vertical Stripe Pattern

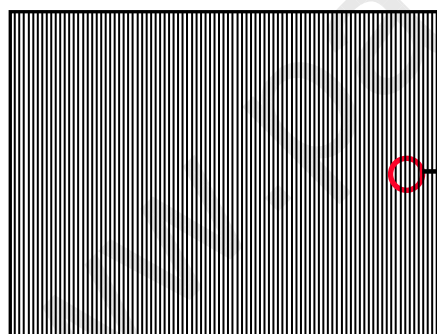

Active Area

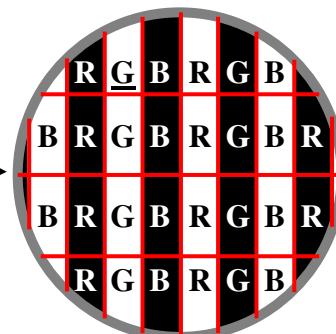

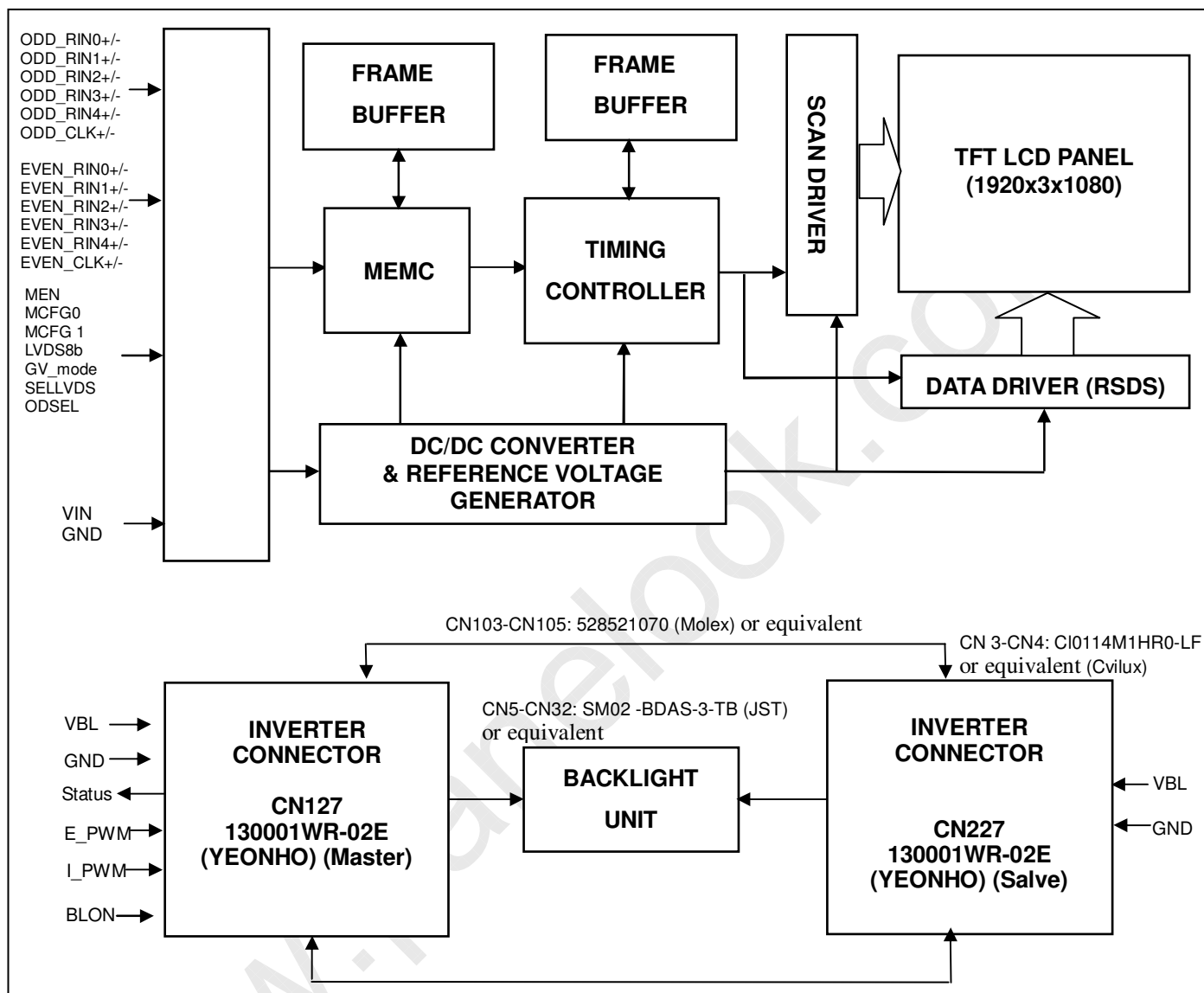
4. BLOCK DIAGRAM OF INTERFACE
4.1 TFT LCD MODULE

5 .INPUT TERMINAL PIN ASSIGNMENT

5.1 TFT LCD Module

CNF1 Connector Part No.: JAE Taiwan (台灣航空電子) FI-RE51S-HF or equivalent.

Pin	Name	Description	Note
1	GND	Ground	
2	MEN	MEMC function selection	4
3	MCFG0	MEMC function selection	4
4	MCFG1	MEMC function selection	4
5	LVDS8b	8bit/10bit LVDS input selection	5
6	GV_mode	Graphic / Video mode selection	6
7	SELLVDS	LVDS data format Selection	2
8	Res.	No Connection	
9	Res.	No Connection	
10	ODSEL	Overdrive Lookup Table Selection	3
11	GND	Ground	
12	ERX0-	2nd pixel Negative LVDS differential data input. Channel 0	
13	ERX0+	2nd pixel Positive LVDS differential data input. Channel 0	
14	ERX1-	2nd pixel Negative LVDS differential data input. Channel 1	
15	ERX1+	2nd pixel Positive LVDS differential data input. Channel 1	
16	ERX2-	2nd pixel Negative LVDS differential data input. Channel 2	
17	ERX2+	2nd pixel Positive LVDS differential data input. Channel 2	
18	GND	Ground	
19	ECLK-	2nd pixel Negative LVDS differential clock input.	
20	ECLK+	2nd pixel Positive LVDS differential clock input.	
21	GND	Ground	
22	ERX3-	2nd pixel Negative LVDS differential data input. Channel 3	
23	ERX3+	2nd pixel Positive LVDS differential data input. Channel 3	
24	ERX4-	2nd pixel Negative LVDS differential data input. Channel 4	
25	ERX4+	2nd pixel Positive LVDS differential data input. Channel 4	
26	N.C.	No Connection	1
27	N.C.	No Connection	1
28	ORX0-	1st pixel Negative LVDS differential data input. Channel 0	
29	ORX0+	1st pixel Positive LVDS differential data input. Channel 0	
30	ORX1-	1st pixel Negative LVDS differential data input. Channel 1	
31	ORX1+	1st pixel Positive LVDS differential data input. Channel 1	
32	ORX2-	1st pixel Negative LVDS differential data input. Channel 2	
33	ORX2+	1st pixel Positive LVDS differential data input. Channel 2	

34	GND	Ground	
35	OCLK-	1st pixel Negative LVDS differential clock input.	
36	OCLK+	1st pixel Positive LVDS differential clock input.	
37	GND	Ground	
38	ORX3-	1st pixel Negative LVDS differential data input. Channel 3	
39	ORX3+	1st pixel Positive LVDS differential data input. Channel 3	
40	ORX4-	1st pixel Negative LVDS differential data input. Channel 4	
41	ORX4+	1st pixel Positive LVDS differential data input. Channel 4	
42	N.C.	No Connection	1
43	N.C.	No Connection	1
44	GND	Ground	
45	GND	Ground	
46	GND	Ground	
47	N.C.	No Connection	
48	VCC	+12V power supply	
49	VCC	+12V power supply	
50	VCC	+12V power supply	
51	VCC	+12V power supply	

Note (1) Reserved for internal use. Please leave it open.

Note (2)

SELLVDS	Mode
L(default)	VESA
H	JEIDA

L: Connect to GND, H: Connect to +3.3V

Note (3) Overdrive lookup table selection. The overdrive lookup table should be selected in accordance with the frame rate to optimize image quality.

ODSEL	Description
L(default)	Lookup table was optimized for 60 Hz frame rate input.
H	Lookup table was optimized for 50 Hz frame rate input.

L: Connect to GND, H: Connect to +3.3V

Note (4) Motion Engine (ME) Level & Demo Function Table

Motion engine level must be adjusted after video mode is selected (or entered).

Adjusting the motion engine level in graphic mode has no effect

		MEN	MCFG1	MCFG0	Notes		
Blanking	Blanking disable	0	0	0	(a)		
	Auto blanking	0	0	1	(b)		
	Blanking enable	0	1	0	(c)		
Effect of ME →					De blur	De judder	Halo
Demo mode (d)		0	1	1	Demo Window		
ME Level	Strong	1	0	0	Enable	Strong	Strong
	Medium(Default)	1	0	1	Enable	Normal	Normal
	Weak	1	1	0	Enable	×	×
	OFF	1	1	1	×	×	×
		(e) (f) (g)					

- (a) Module re-starts processing video signals from Frontend scaler control board.
- (b) During sync unstable period such as format change, 60Hz <-> 50Hz .
MCFG0 can be used to insert blanking of 500ms. This signal is toggled.
- (c) Module continues to insert blanking until blanking disable signal is received from frontend scaler board.
- (d) Demo window mode: Demo Window appears to the left half of display area. Left side with frame is 120Hz with MEMC, and right side is 120Hz w/o motion compensation.
- (e) GPIO (General Purpose I/O) sequence of ME Level: (1) MEN; (2) MCFG1; (3) MCFG0.
GPIO sequence of Blanking Enable, Blanking Disable and Demo window: (1) MCFG1; (2) MCFG0; (3) MEN.
- (f) Each scaler command must be maintained the same voltage level at least 100ms.
- (g) 0 : Connect to GND, 1 : +3.3V

Note (5) 8bit/10bit LVDS input selection

LVDS8b	Bit depth
H(default)	8bit
L	10bit

L : Connect to GND, H : Connect to +3.3V

Note (6) Graphic / Video mode selection

There is no prohibited time period for switching between Graphic mode and Video mode.

When this switching signal is input, LCD will be reset and will re-start selected mode.

GV_mode	Mode select	MEMC ON/OFF
H(default)	Graphic mode	MEMC OFF
L	Video mode	MEMC ON

L : Connect to GND, H : Connect to +3.3V

6. INTERFACE TIMING

6.1 INPUT SIGNAL TIMING SPECIFICATIONS

The input signal timing specifications are shown as the following table and timing diagram.

Signal	Item	Symbol	Min.	Typ.	Max.	Unit	Note
LVDS Receiver Clock	Frequency	1/Tc	60	74.25	78	MHz	-
	Input cycle to cycle jitter	Trcl	-	-	200	ps	-
LVDS Receiver Data	Setup Time	Tlvsu	600	-	-	ps	-
	Hold Time	Tlvhd	600	-	-	ps	-
Vertical Active Display Term	Frame Rate		57	60	61	Hz	-
			47	50	53		
	Total	Tv	1115	1125	1135	Th	Tv=Tvd+Tvb
	Display	Tvd	1080	1080	1080	Th	-
	Blank	Tvb	35	45	55	Th	-
Horizontal Active Display Term	Total	Th	1050	1100	1150	Tc	Th=Thd+Thb
	Display	Thd	960	960	960	Tc	-
	Blank	Thb	90	140	190	Tc	-

6.2 INTERNAL SIGNAL TIMING SPECIFICATIONS (FRC→ T-CON)

The input signal timing specifications are shown as the following table and timing diagram.

Signal	Item	Symbol	Min.	Typ.	Max.	Unit	Note
LVDS Receiver Clock	Frequency	1/Tc	60	74.25	78	MHz	-
	Input cycle to cycle jitter	Trcl	-	-	200	ps	-
LVDS Receiver Data	Setup Time	Tlvsu	600	-	-	ps	-
	Hold Time	Tlvhd	600	-	-	ps	-
Vertical Active Display Term	Frame Rate		57	60	61	Hz	-
			47	50	53		
	Total	Tv	1115	1125	1135	Th	Tv=Tvd+Tvb
	Display	Tvd	1080	1080	1080	Th	-
	Blank	Tvb	35	45	55	Th	-
Horizontal Active Display Term	Total	Th	1050	1100	1150	Tc	Th=Thd+Thb
	Display	Thd	960	960	960	Tc	-
	Blank	Thb	90	140	190	Tc	-

Note : Since the module is operated in DE only mode, Hsync and Vsync input signals should be set to low logic level. Otherwise, this module would operate abnormally.

Note(1) : LVDS Clock should not over 80MHz even if H-total or V-total is in spec, and the frequency follows the equation below.

$$\text{LVDS CLK} = \text{Frame rate} * \text{H-total} * \text{V-total}$$

INPUT SIGNAL TIMING DIAGRAM

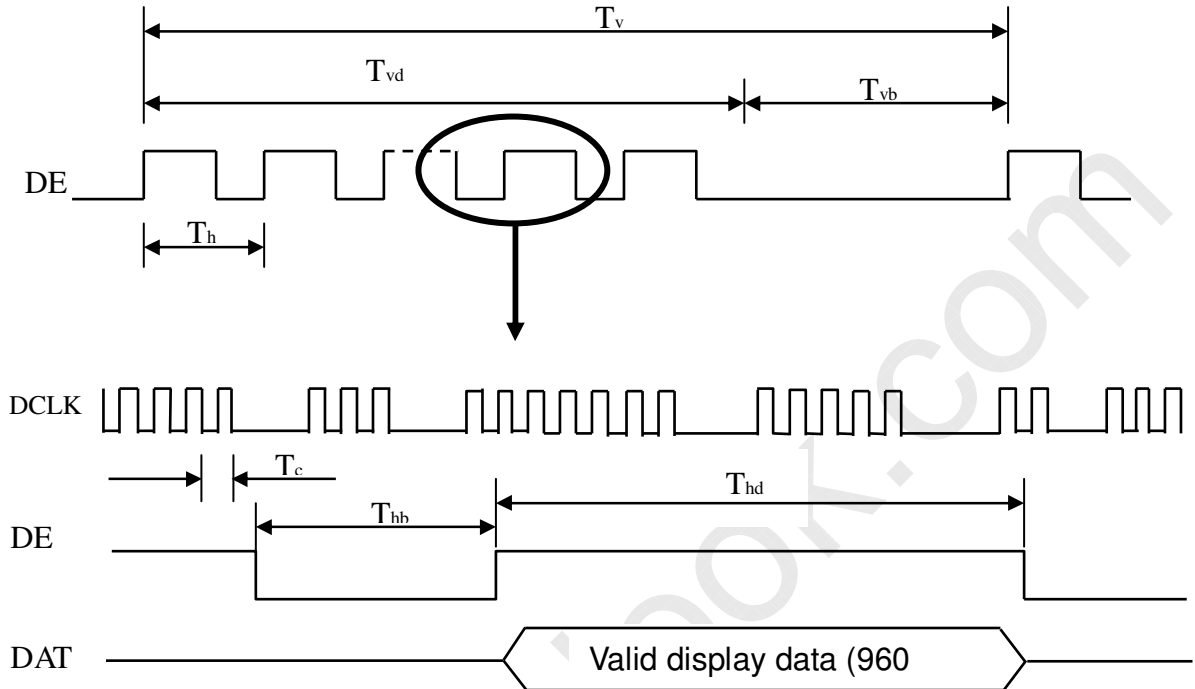

LVDS RECEIVER INTERFACE TIMING DIAGRAM

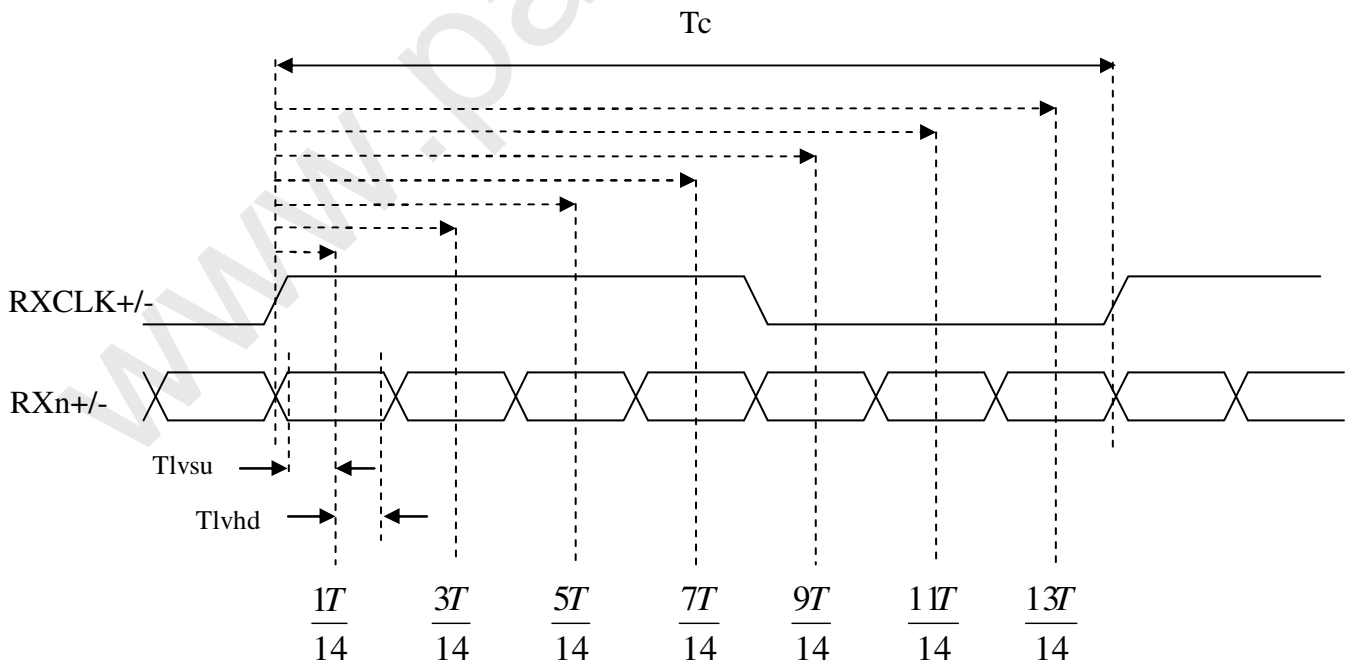

6.3 POWER ON/OFF SEQUENCE

To prevent a latch-up or DC operation of LCD module, the power on/off sequence should follow the diagram below.

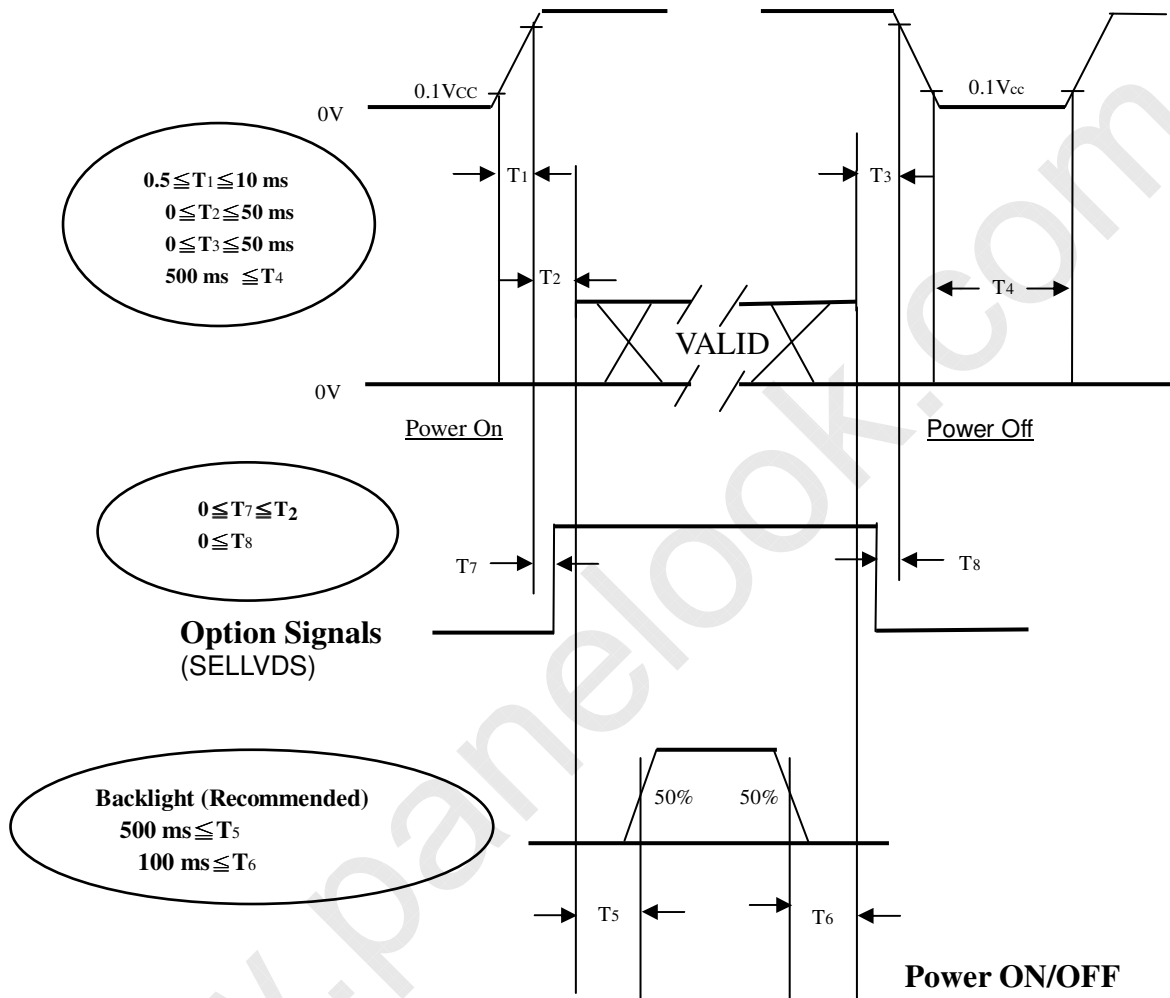

Note :

- (1) The supply voltage of the external system for the module input should follow the definition of Vcc.
- (2) Apply the lamp voltage within the LCD operation range. When the backlight turns on before the LCD operation or the LCD turns off before the backlight turns off, the display may momentarily become abnormal screen.
- (3) In case of VCC is in off level, please keep the level of input signals on the low or high impedance.
- (4) T4 should be measured after the module has been fully discharged between power off and on period.
- (5) Interface signal shall not be kept at high impedance when the power is on.

7. OPTICAL CHARACTERISTICS

7.1 TEST CONDITIONS

Item	Symbol	Value	Unit
Ambient Temperature	Ta	25±2	°C
Ambient Humidity	Ha	50±10	%RH
Supply Voltage	V _{CC}	12	V
Input Signal	According to typical value in "3. ELECTRICAL CHARACTERISTICS"		
Vertical Frame Rate	Fr	120	Hz

7.2 OPTICAL SPECIFICATIONS

The relative measurement methods of optical characteristics are shown in 7.2. The following items should be measured under the test conditions described in 7.1 and stable environment shown in Note (7).

Item	Symbol	Condition	Min.	Typ.	Max.	Unit	Note	
Contrast Ratio	CR		3000	4000	-	-	(2), (4)	
Response Time	Gray to gray	$\theta_x=0^\circ, \theta_Y=0^\circ$	-	4.5	9	ms	(5)	
Center Transmittance	T%	With CMO Module	-	5.3	-	%	(2), (8)	
White Variation	δW		-	-	1.3	-	(2), (7)	
Color Chromaticity	Red	Rcx	$\theta_x=0^\circ, \theta_Y=0^\circ$ CS-1000T Standard light source "C"	Typ - 0.03	Typ + 0.03	-	(1),(6)	
		Rcy				-		
	Green	Gcx				0.299		-
		Gcy				0.599		-
	Blue	Bcx				0.148		-
		Bcy				0.099		-
	White	Wcx				0.333		-
		Wcy				0.372		-
Viewing Angle	Horizontal	θ_{x+}	CR≥20 With CMO Module	80	88	-	Deg. (2), (3)	
		θ_{x-}				-		
	Vertical	θ_{Y+}				-		
		θ_{Y-}				-		

Note (1) Light source is the standard light source "C" which is defined by CIE and driving voltages are based on suitable gamma voltages. The calculating method is as following :

1. Measure Module's and BLU's spectrums. W, R, G, B are with signal input. BLU(for V546H1-LH1) is supplied by CMO.
2. Calculate cell's spectrum.
3. Calculate cell's chromaticity by using the spectrum of standard light source "C"

Note (2) Light source is the BLU which is supplied by CMO and driving voltages are based on suitable gamma voltages.

Note (3) Definition of Viewing Angle (θ_x, θ_y):

Viewing angles are measured by Conoscope

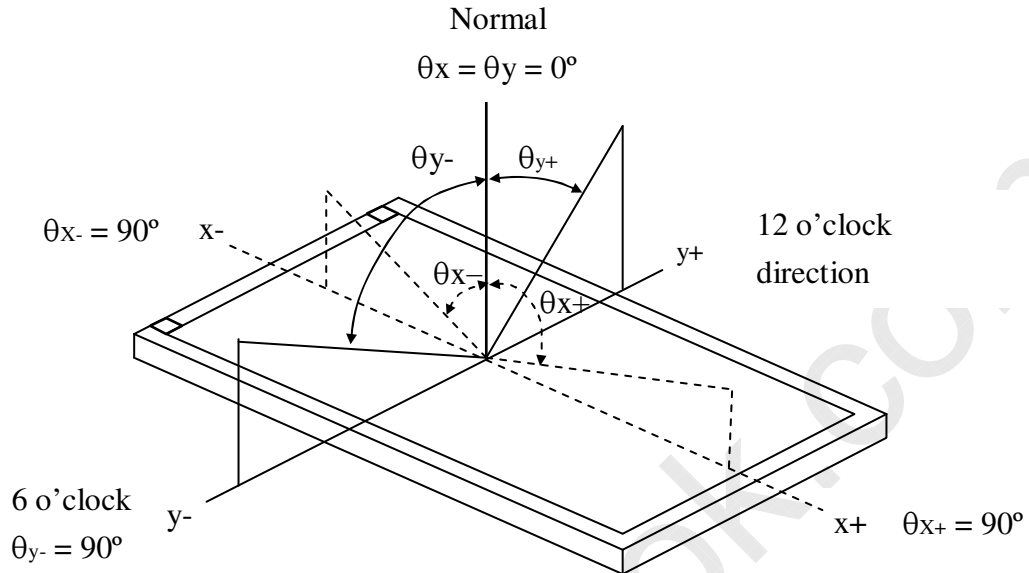

Note (4) Definition of Contrast Ratio (CR):

The contrast ratio can be calculated by the following expression.

$$\text{Contrast Ratio (CR)} = L_{1023} / L_0$$

L_{1023} : Luminance of gray level 1023

L_0 : Luminance of gray level 0

$CR = CR(X)$, where $CR(X)$ is corresponding to the Contrast Ratio of the point X at Figure in Note (8).

Note (5) Definition of Gray to Gray Switching Time:

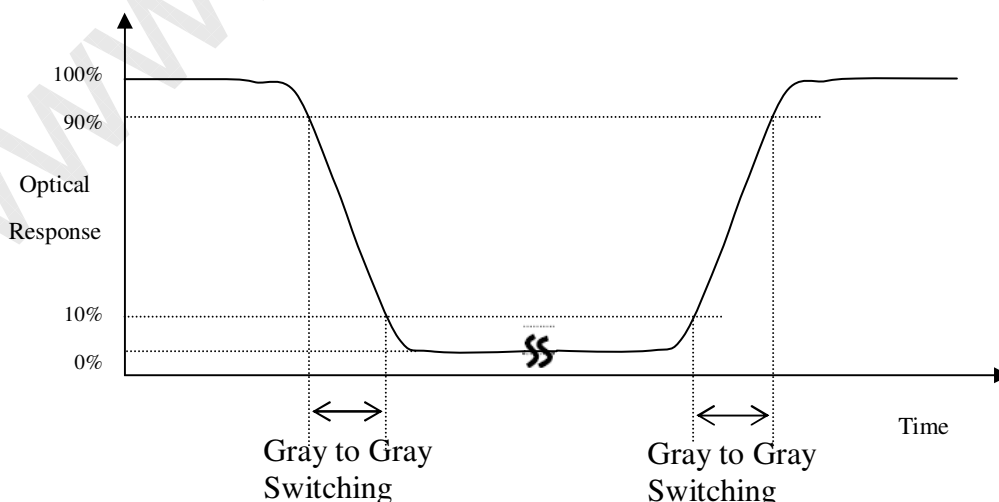

Note (6) Measurement Setup:

The LCD module should be stabilized at given temperature for 1 hour to avoid abrupt temperature change during measuring. In order to stabilize the luminance, the measurement should be executed after lighting backlight for 1 hour in a windless room.

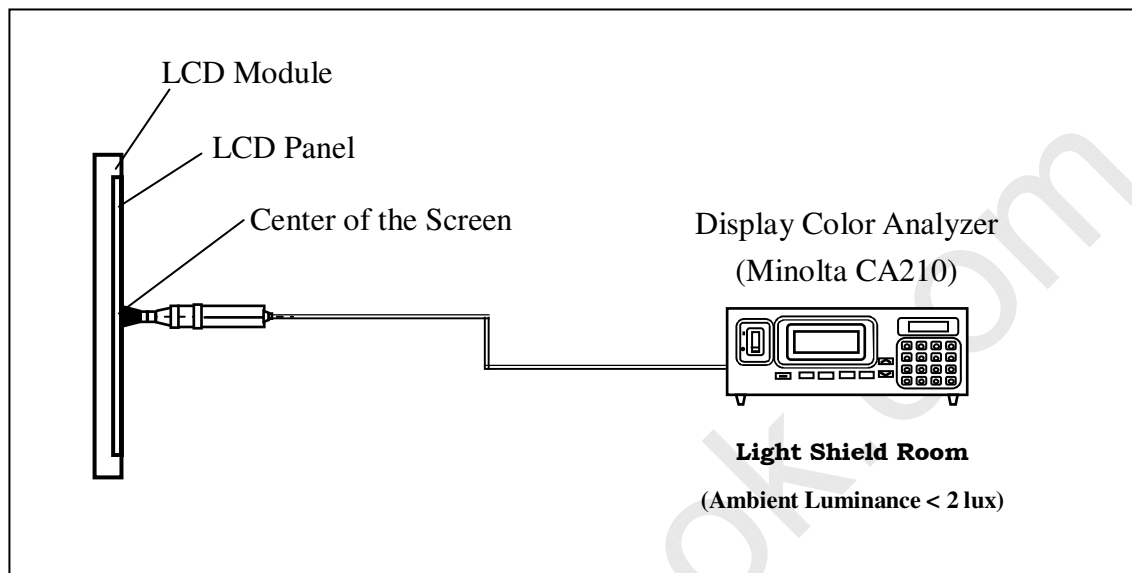

Note (7) Definition of White Variation (δW):

Measure the luminance of gray level 1023 at 5 points

$$\delta W = \text{Maximum} [L(1), L(2), L(3), L(4), L(5)] / \text{Minimum} [L(1), L(2), L(3), L(4), L(5)]$$

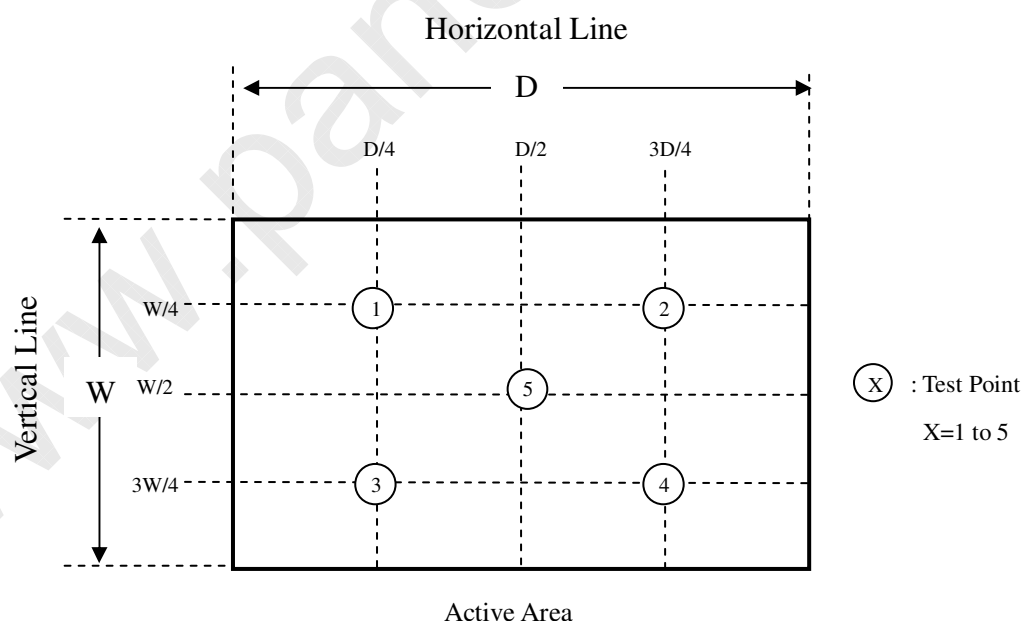

Note (8) Definition of Transmittance (T%):

Module is without signal input.

$$\text{Transmittance} = \frac{\text{Luminance of LCD module}}{\text{Luminance of backlight}} * 100\%$$

8. PRECAUTIONS

8.1 ASSEMBLY AND HANDLING PRECAUTIONS

- [1] Do not apply rough force such as bending or twisting to the module during assembly.
- [2] It is recommended to assemble or to install a module into the user's system in clean working areas. The dust and oil may cause electrical short or worsen the polarizer.
- [3] Do not apply pressure or impulse to the module to prevent the damage of LCD panel and Backlight.
- [4] Always follow the correct power-on sequence when the LCD module is turned on. This can prevent the damage and latch-up of the CMOS LSI chips.
- [5] Do not plug in or pull out the I/F connector while the module is in operation.
- [6] Do not disassemble the module.
- [7] Use a soft dry cloth without chemicals for cleaning, because the surface of polarizer is very soft and easily scratched.
- [8] Moisture can easily penetrate into LCD module and may cause the damage during operation.
- [9] When storing modules as spares for a long time, the following precaution is necessary.
 - [9.1] Do not leave the module in high temperature, and high humidity for a long time. It is highly recommended to store the module with temperature from 0 to 35°C at normal humidity without condensation.
 - [9.2] The module shall be stored in dark place. Do not store the TFT-LCD module in direct sunlight or fluorescent light.
- [10] When ambient temperature is lower than 10°C, the display quality might be reduced. For example, the response time will become slow, and the starting voltage of CCFL will be higher than that of room temperature.

8.2 SAFETY PRECAUTIONS

- [1] The startup voltage of a Backlight is approximately 1000 Volts. It may cause an electrical shock while assembling with the inverter. Do not disassemble the module or insert anything into the Backlight unit.
- [2] If the liquid crystal material leaks from the panel, it should be kept away from the eyes or mouth. In case of contact with hands, skin or clothes, it has to be washed away thoroughly with soap.
- [3] After the module's end of life, it is not harmful in case of normal operation and storage.

9. DEFINITION OF LABELS

9.1 OPEN CELL LABEL

The barcode nameplate is pasted on each open cell as illustration for CMO internal control.

V546H1-PH5



XXXXXXXXXXXXXXXXXX

9.2 CARTON LABEL

The barcode nameplate is pasted on each box as illustration, and its definitions are as following explanation.

 CHI MEI OPTOELECTRONICS	RoHS
PO.NO. _____	
Part ID. _____	
Model Name _____	
Carton ID. _____ Quantities _____	

- (a) Model Name: V546H1-PH5
- (b) Carton ID: CMO internal control
- (c) Quantities: 6 pcs

10. PACKAGING

10.1 PACKAGING SPECIFICATIONS

- (1) 6 LCD TV Panels / 1 Box
- (2) Box dimensions : 1454 (L) X 994 (W) X 210 (H)
- (3) Weight : approximately 42Kg (6 panels per box)

10.2 PACKAGING METHOD

Figures 10-1 and 10-2 are the packing method

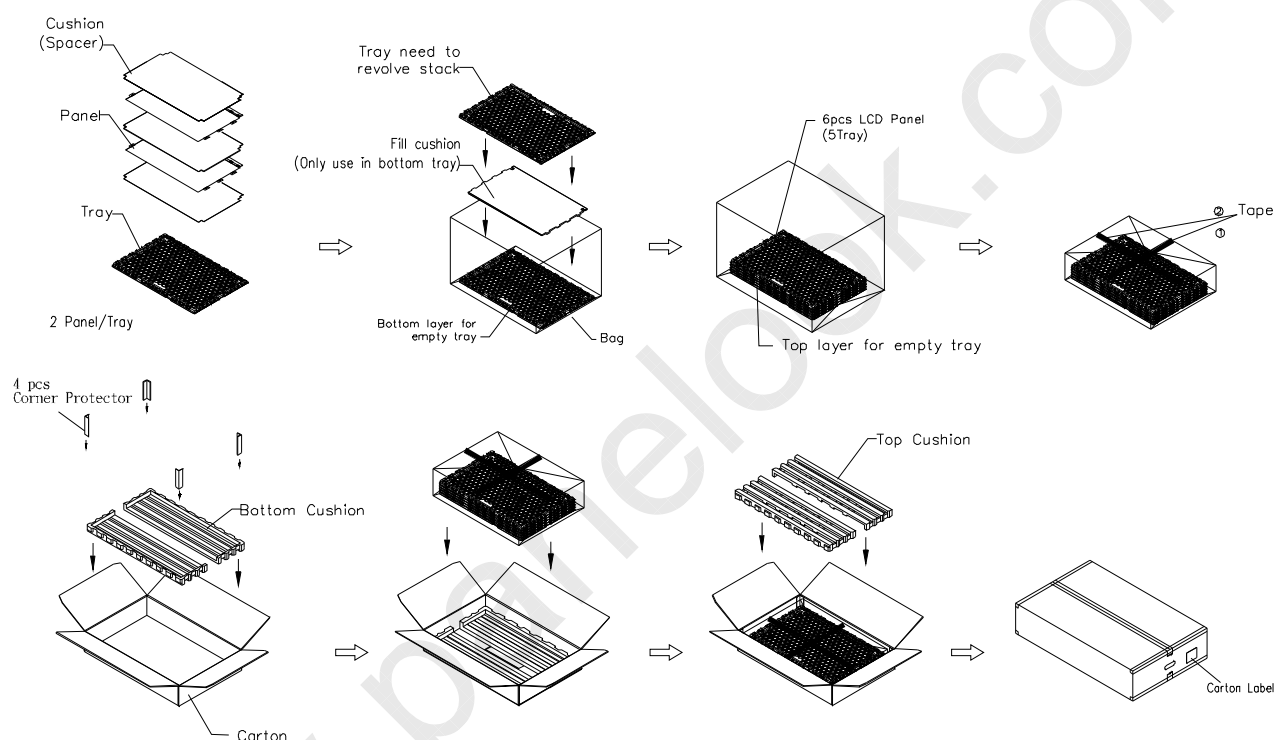
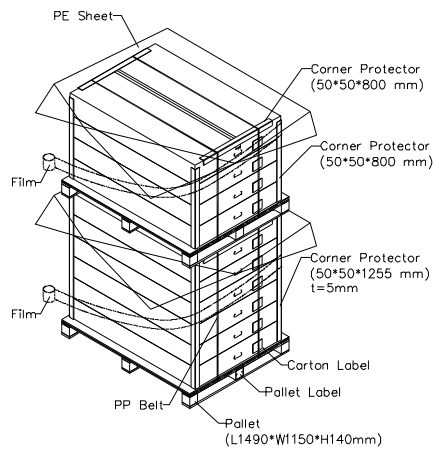

Figure.10-1 packing method

Sea / Land Transportation
(40ft HQ Container)

Gross: 450kg



Sea / Land Transportation
Gross: 408kg

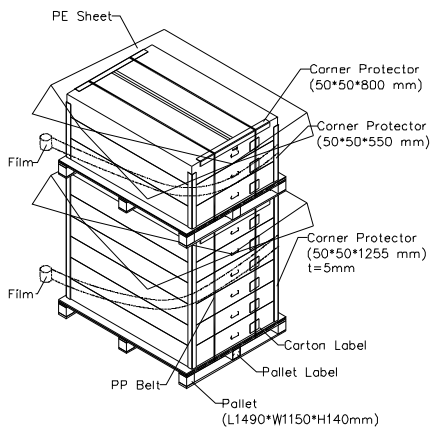

Air Transportation
Gross: 267kg

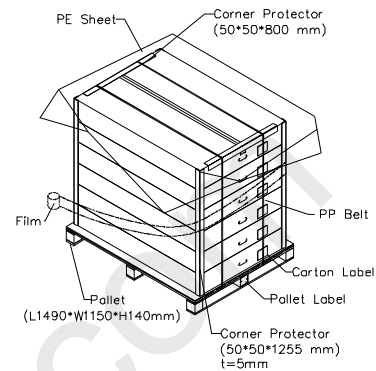

Figure.10-2 packing method



11. MECHANICAL CHARACTERISTICS

