

- Tentative Specification
- Preliminary Specification
- Approval Specification

MODEL NO.: V546HK2
SUFFIX: PE1

Customer:	
APPROVED BY	SIGNATURE
Name / Title _____	_____
Note	
<hr/> Please return 1 copy for your confirmation with your signature and comments.	

Approved By	Checked By	Prepared By
Chao-Chun Chung	Josh Chi	Andy Chen

CONTENTS

REVISION HISTORY	4
1. GENERAL DESCRIPTION	5
1.1 OVERVIEW	5
1.2 FEATURES	5
1.3 MECHANICAL SPECIFICATIONS	5
2. ABSOLUTE MAXIMUM RATINGS	6
2.1 ABSOLUTE RATINGS OF ENVIRONMENT	6
2.2 PACKAGE STORAGE	7
2.3 ELECTRICAL ABSOLUTE RATINGS	7
2.3.1 TFT LCD MODULE	7
3. ELECTRICAL CHARACTERISTICS	8
3.1 TFT LCD MODULE	8
4. BLOCK DIAGRAM OF INTERFACE	11
4.1 TFT LCD MODULE	11
INPUT CONNECTOR	11
5. INPUT TERMINAL PIN ASSIGNMENT	12
5.1 TFT LCD MODULE INPUT	12
5.2 LVDS INTERFACE	16
5.3 COLOR DATA INPUT ASSIGNMENT	17
5.4 FLICKER (Vcom) ADJUSTMENT	18
6. INTERFACE TIMING	19
6.1 INPUT SIGNAL TIMING SPECIFICATIONS	19
6.2 POWER ON/OFF SEQUENCE	22
7. OPTICAL CHARACTERISTICS	23
7.1 TEST CONDITIONS	23
7.2 OPTICAL SPECIFICATIONS	24
8. PRECAUTIONS	27
8.1 ASSEMBLY AND HANDLING PRECAUTIONS	27

8.2 SAFETY PRECAUTIONS.....	28
9. DEFINITION OF LABELS.....	29
9.1 OPEN CELL LABEL	29
9.2 CARTON LABEL	29
10 . PACKAGING.....	30
11. MECHANICAL CHARACTERISTIC.....	32

REVISION HISTORY

Version	Date	Page(New)	Section	Description
Ver. 2.0	Fab.25, 2011	All	All	The approval specification was first issued.

1. GENERAL DESCRIPTION

1.1 OVERVIEW

V546HK2-PE1 is a 54.6" TFT Liquid Crystal Display product with driver ICs and 4ch-LVDS interface. This product supports 1920 x 1080 Full HDTV format and can display 1.07G colors (8-bit+Hi-FRC/color). The backlight unit is not built in.

1.2 FEATURES

CHARACTERISTICS ITEMS	SPECIFICATIONS
Screen Diagonal [in]	54.6
Pixels [lines]	1920 × 1080
Active Area [mm]	1209.6(H) × 680.4(V) (54.6" diagonal)
Sub-Pixel Pitch [mm]	0.1615(H) × 0.4845(V)
Pixel Arrangement	RGB vertical stripe
Weight [g]	TYP. 3360
Physical Size [mm]	1243.68(W) × 737.55(H) × 1.75(D) Typ
Display Mode	Transmissive mode / Normally black
Contrast Ratio	6000:1 Typ. (Typical value measure at CMI's module)
Glass thickness (Array / CF) [mm]	0.7 / 0.7
Viewing Angle (CR>20)	+88/-88(H), +88/-88(V) Typ. (CR ≥ 20) (Typical value measure at CMI's module)
Color Chromaticity	R = (0.655, 0.328) G = (0.266, 0.583) B = (0.131, 0.116) W = (0.301, 0.358) * Please refer to "color chromaticity" on p.23
Cell Transparency [%]	5.5%
Polarizer Surface Treatment	Super clear coating , Hardness(3H)

1.3 MECHANICAL SPECIFICATIONS

Item	Min.	Typ.	Max.	Unit	Note
Weight	3310	3360	3410	g	-
I/F connector mounting position	The mounting inclination of the connector makes the screen center within ± 0.5mm as the horizontal.				(2)

Note (1) Please refer to the attached drawings for more information of front and back outline dimensions.

Note (2) Connector mounting position

2. ABSOLUTE MAXIMUM RATINGS

2.1 ABSOLUTE RATINGS OF ENVIRONMENT

Item	Symbol	Value		Unit	Note
		Min.	Max.		
Storage Temperature	TST	-20	+60	°C	(1)
Operating Ambient Temperature	TOP	0	50	°C	(1), (2)

Note (1) Temperature and relative humidity range is shown in the figure below.

(a) 90 %RH Max. ($T_a \leq 40$ °C).

(b) Wet-bulb temperature should be 39 °C Max. ($T_a > 40$ °C).

(c) No condensation.

Note (2) The maximum operating temperature is based on the test condition that the surface temperature of display area is less than or equal to 65 °C with LCD module alone in a temperature controlled chamber. Thermal management should be considered in final product design to prevent the surface temperature of display area from being over 65 °C. The range of operating temperature may degrade in case of improper thermal management in final product design.

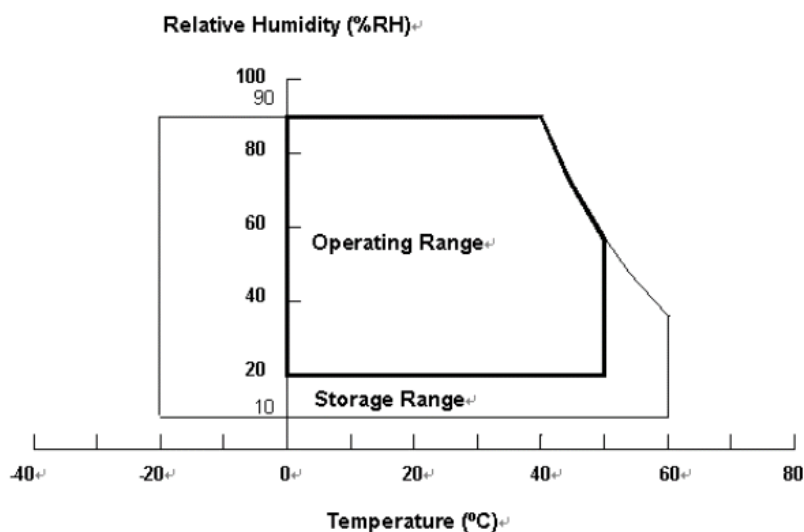

2.2 PACKAGE STORAGE

When storing modules as spares for a long time, the following precaution is necessary.

- (a) Do not leave the module in high temperature, and high humidity for a long time, It is highly recommended to store the module with temperature from 0 to 35 °C at normal humidity without condensation.
- (b) The module shall be stored in dark place. Do not store the TFT-LCD module in direct sunlight or fluorescent light.

2.3 ELECTRICAL ABSOLUTE RATINGS

2.3.1 TFT LCD MODULE

Item	Symbol	Value		Unit	Note
		Min.	Max.		
Power Supply Voltage	VCC	-0.3	13.5	V	(1)
Logic Input Voltage	VIN	-0.3	3.6	V	

3. ELECTRICAL CHARACTERISTICS

3.1 TFT LCD MODULE

(Ta = 25 ± 2 °C)

Parameter		Symbol	Value			Unit	Note
			Min.	Typ.	Max.		
Power Supply Voltage		V _{CC}	10.8	12	13.2	V	(1)
Rush Current		I _{RUSH}	—	—	4	A	(2)
Power Supply Current	White Pattern	—	—	0.63	—	A	(3)
	Horizontal Stripe	—	—	1.37	1.64	A	
	Black Pattern	—	—	0.63	—	A	
LVDS interface	Differential Input High Threshold Voltage	V _{LVTH}	+100	—	—	mV	(4)
	Differential Input Low Threshold Voltage	V _{LVTL}	—	—	-100	mV	
	Common Input Voltage	V _{CM}	1.0	1.2	1.4	V	
	Differential input voltage	V _{ID}	200	—	600	mV	
	Terminating Resistor	R _T	—	100	—	ohm	
CMOS interface	Input High Threshold Voltage	V _{IH}	2.7	—	3.3	V	
	Input Low Threshold Voltage	V _{IL}	0	—	0.7	V	

Note (1) The module should be always operated within the above ranges.

Note (2) Measurement condition:

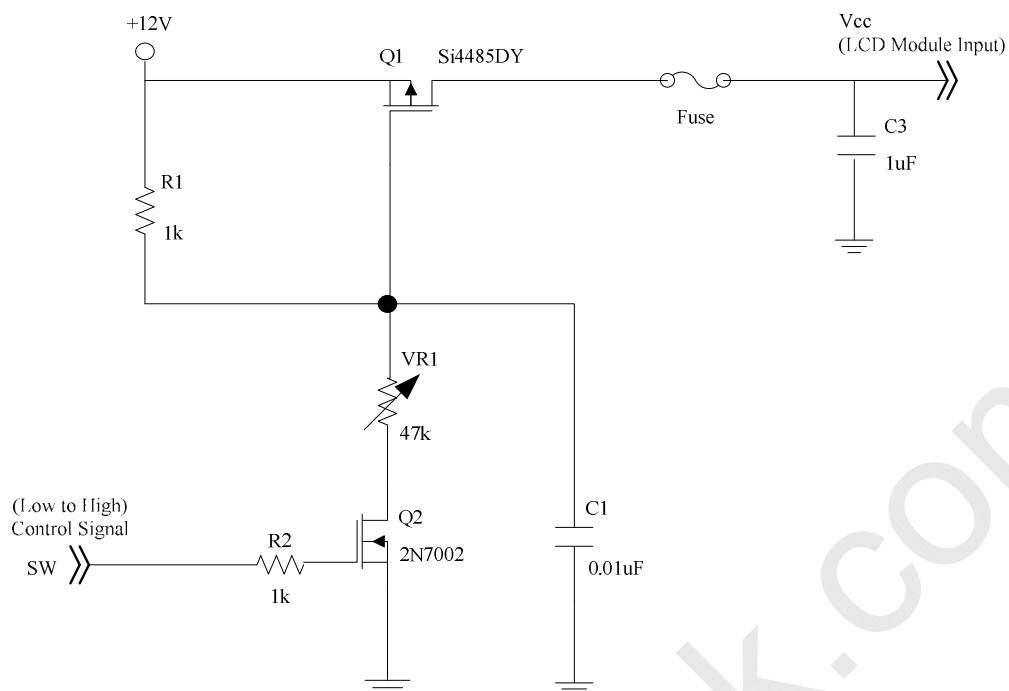

Vcc rising time is 470us

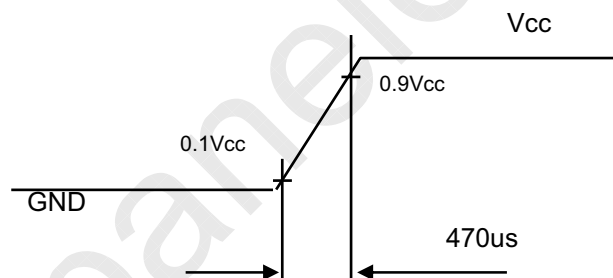

Note (3) The specified power supply current is under the conditions at $V_{cc} = 12\text{ V}$, $T_a = 25 \pm 2\text{ }^\circ\text{C}$, $f_v = 120\text{ Hz}$, whereas a power dissipation check pattern below is displayed.

a. White Pattern

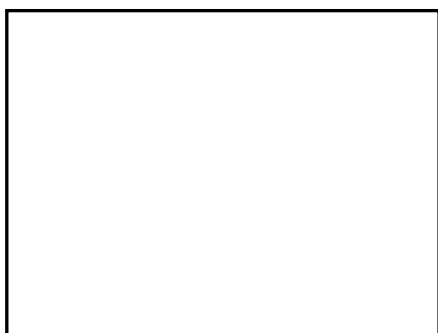

Active Area

b. Black Pattern

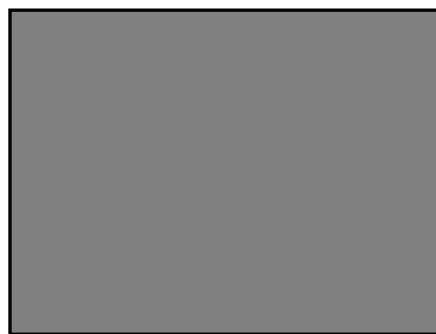

Active Area

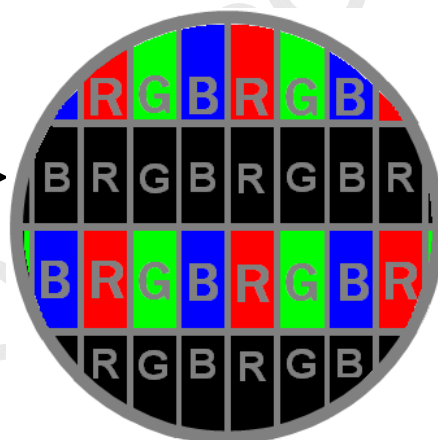
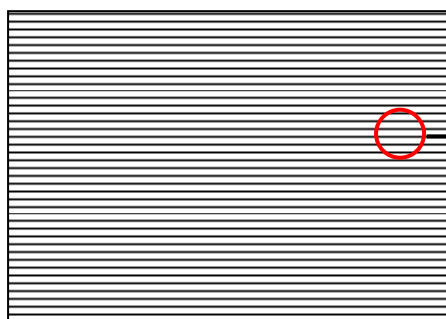

Note (4) The LVDS input characteristics are as follows:

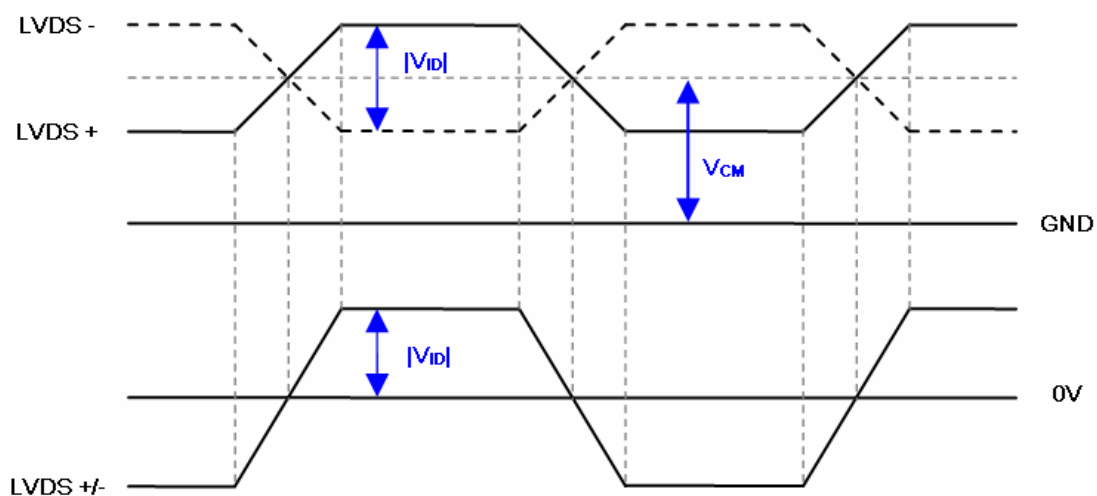

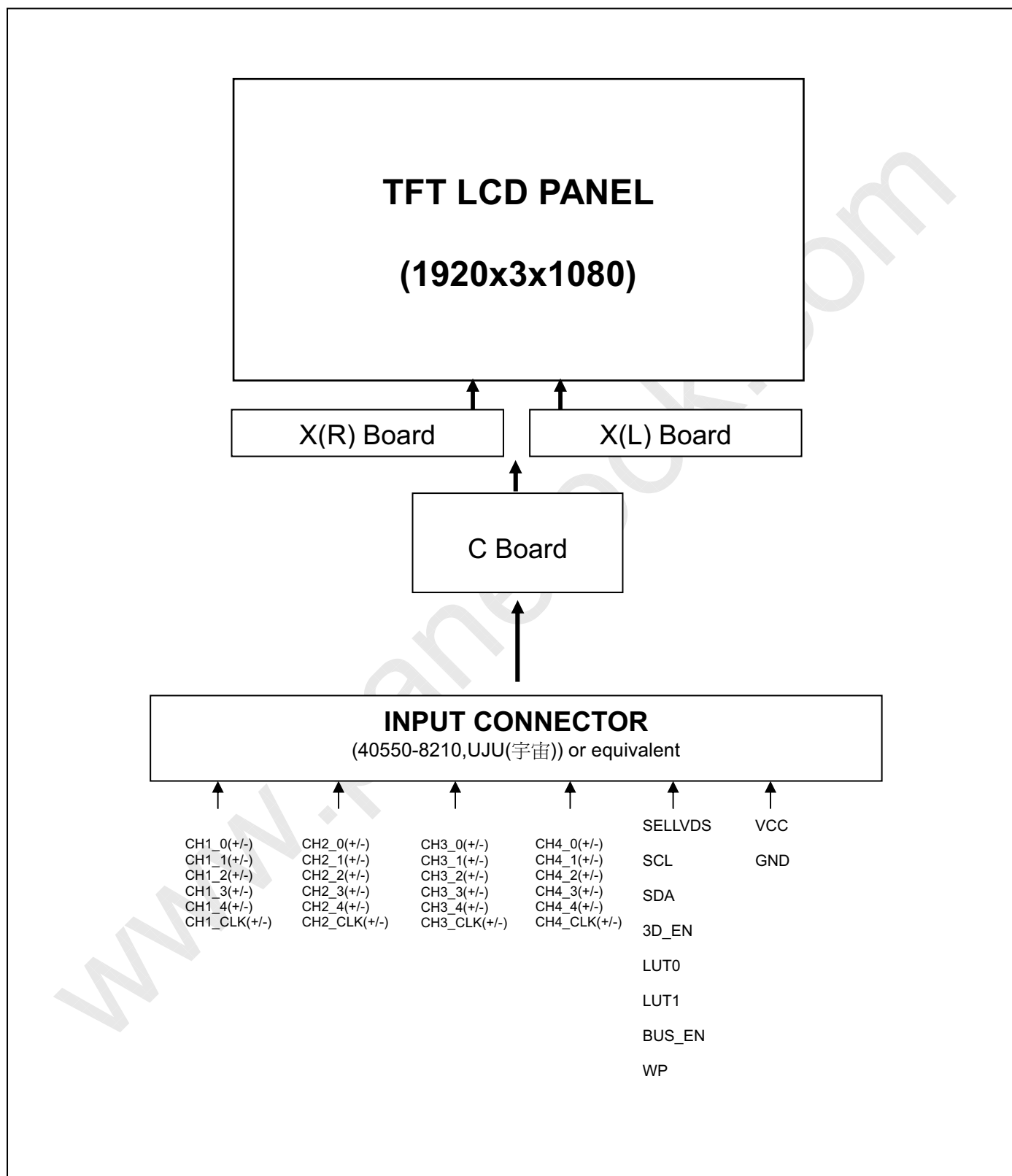
4. BLOCK DIAGRAM OF INTERFACE
4.1 TFT LCD MODULE

5. INPUT TERMINAL PIN ASSIGNMENT

5.1 TFT LCD MODULE INPUT

CNF1 Connector Pin Assignment (FP7S082HA1R1200, JAE Taiwan(台灣航空電子) or equivalent)

Pin	Name	Description	Note
1	VCC	+12V power supply	
2	VCC	+12V power supply	
3	VCC	+12V power supply	
4	VCC	+12V power supply	
5	VCC	+12V power supply	
6	N.C.	No Connection	(1)
7	GND	Ground	
8	GND	Ground	
9	GND	Ground	
10	CH1[0]-	First pixel Negative LVDS differential data input. Pair 0	
11	CH1[0]+	First pixel Positive LVDS differential data input. Pair 0	
12	CH1[1]-	First pixel Negative LVDS differential data input. Pair 1	
13	CH1[1]+	First pixel Positive LVDS differential data input. Pair 1	
14	CH1[2]-	First pixel Negative LVDS differential data input. Pair 2	
15	CH1[2]+	First pixel Positive LVDS differential data input. Pair 2	
16	GND	Ground	
17	CH1CLK-	First pixel Negative LVDS differential clock input.	
18	CH1CLK+	First pixel Positive LVDS differential clock input.	
19	GND	Ground	
20	CH1[3]-	First pixel Negative LVDS differential data input. Pair 3	
21	CH1[3]+	First pixel Positive LVDS differential data input. Pair 3	
22	CH1[4]-	First pixel Negative LVDS differential data input. Pair 4	
23	CH1[4]+	First pixel Positive LVDS differential data input. Pair 4	
24	GND	Ground	
25	CH3[0]-	Third pixel Negative LVDS differential data input. Pair 0	
26	CH3[0]+	Third pixel Positive LVDS differential data input. Pair 0	
27	CH3[1]-	Third pixel Negative LVDS differential data input. Pair 1	
28	CH3[1]+	Third pixel Positive LVDS differential data input. Pair 1	

29	CH3[2]-	Third pixel Negative LVDS differential data input. Pair 2	
30	CH3[2]+	Third pixel Positive LVDS differential data input. Pair 2	
31	GND	Ground	
32	CH3CLK-	Third pixel Negative LVDS differential clock input.	
33	CH3CLK+	Third pixel Positive LVDS differential clock input.	
34	GND	Ground	
35	CH3[3]-	Third pixel Negative LVDS differential data input. Pair 3	
36	CH3[3]+	Third pixel Positive LVDS differential data input. Pair 3	
37	CH3[4]-	Third pixel Negative LVDS differential data input. Pair 4	
38	CH3[4]+	Third pixel Positive LVDS differential data input. Pair 4	
39	GND	Ground	
40	SCL	I2C Bus	
41	3D_EN	3D Enable	(3)
42	LUT0	Look UP Table Select	(4)
43	Bus_EN	Bus Switch Enable	
44	SDA	I2C Bus	
45	LVDS_SEL	LVDS Data Format Selection	(2)
46	N.C.	No Connection	(1)
47	N.C.	No Connection	(1)
48	N.C.	No Connection	(1)
49	WP	Write Protection for EEPROM	
50	LUT1	Look UP Table Select	(4)
51	N.C.	No Connection	(1)
52	GND	Ground	
53	CH4[4]+	Fourth pixel Positive LVDS differential data input. Pair 4	
54	CH4[4]-	Fourth pixel Negative LVDS differential data input. Pair 4	
55	CH4[3]+	Fourth pixel Positive LVDS differential data input. Pair 3	
56	CH4[3]-	Fourth pixel Negative LVDS differential data input. Pair 3	
57	GND	Ground	
58	CH4CLK+	Fourth pixel Positive LVDS differential clock input.	
59	CH4CLK-	Fourth pixel Negative LVDS differential clock input.	
60	GND	Ground	

61	CH4[2]+	Fourth pixel Positive LVDS differential data input. Pair 2	
62	CH4[2]-	Fourth pixel Negative LVDS differential data input. Pair 2	
63	CH4[1]+	Fourth pixel Positive LVDS differential data input. Pair 1	
64	CH4[1]-	Fourth pixel Negative LVDS differential data input. Pair 1	
65	CH4[0]+	Fourth pixel Positive LVDS differential data input. Pair 0	
66	CH4[0]-	Fourth pixel Negative LVDS differential data input. Pair 0	
67	GND	Ground	
68	CH2[4]+	Second pixel Positive LVDS differential data input. Pair 4	
69	CH2[4]-	Second pixel Negative LVDS differential data input. Pair 4	
70	CH2[3]+	Second pixel Positive LVDS differential data input. Pair 3	
71	CH2[3]-	Second pixel Negative LVDS differential data input. Pair 3	
72	GND	Ground	
73	CH2CLK+	Second pixel Positive LVDS differential clock input.	
74	CH2CLK-	Second pixel Negative LVDS differential clock input.	
75	GND	Ground	
76	CH2[2]+	Second pixel Positive LVDS differential data input. Pair 2	
77	CH2[2]-	Second pixel Negative LVDS differential data input. Pair 2	
78	CH2[1]+	Second pixel Positive LVDS differential data input. Pair 1	
79	CH2[1]-	Second pixel Negative LVDS differential data input. Pair 1	
80	CH2[0]+	Second pixel Positive LVDS differential data input. Pair 0	
81	CH2[0]-	Second pixel Negative LVDS differential data input. Pair 0	
82	GND	Ground	

Note (1) Reserved for internal use. Please leave it open.

Note (2) High=connect to +3.3V : VESA Format ; Low= connect to GND or Open : JEIDA Format.

Note (3) High=connect to +3.3V : 3D mode ; Low= connect to GND or Open : 2D mode.

Note (4) Look up Table. Select

LUT1	LUT0	Table
0	0	2D OD
0	1	3D OD (High Temperature)
1	0	3D OD (Room Temperature)
1	1	3D OD (Low Temperature)

Note (5) Interface optional pin has internal scheme as following diagram. Customer should keep the interface voltage level requirement as below.

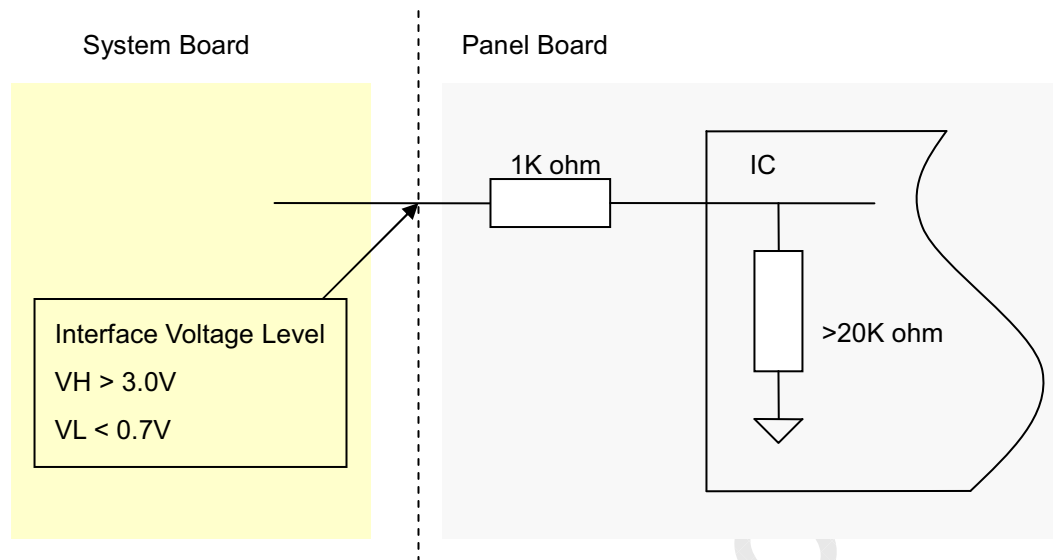

Note (6) LVDS 4-port Data Mapping

Port	Channel of LVDS	Data Stream
1st Port	First Pixel	1, 5, 9,1913, 1917
2nd Port	Second Pixel	2, 6, 10,1914, 1918
3rd Port	Third Pixel	3, 7, 11,1915, 1919
4th Port	Fourth Pixel	4, 8, 12,1916, 1920

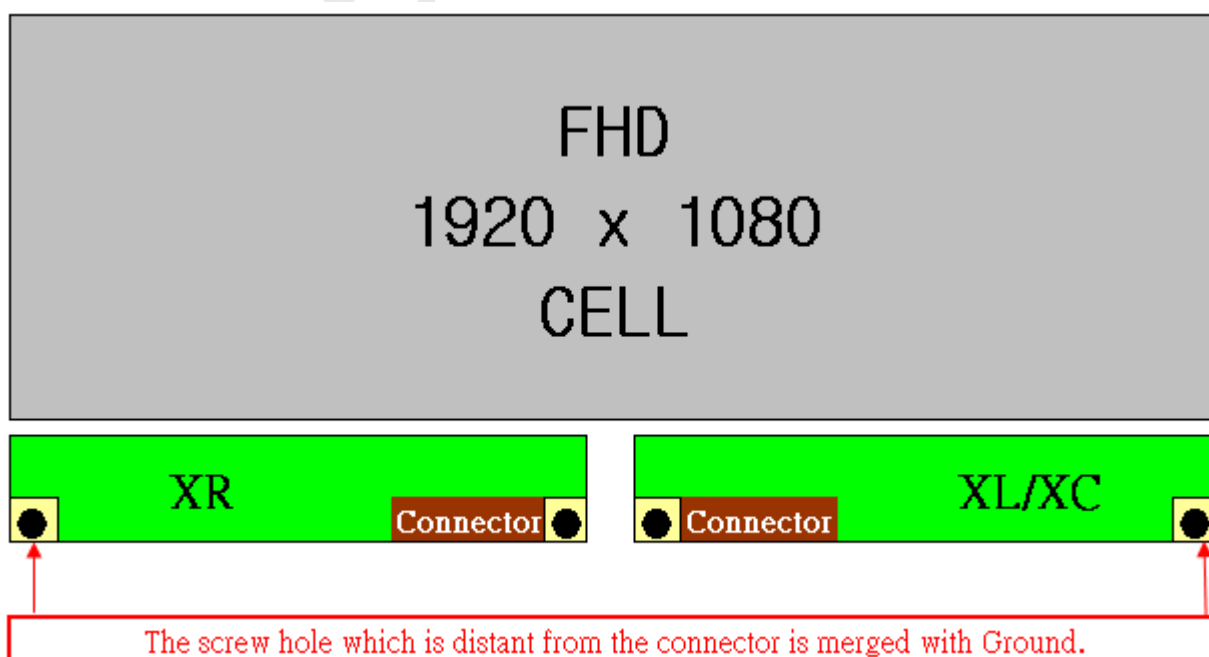

5.2 LVDS INTERFACE

VESA Format : SELLVDS = H

JEIDA Format : SELLVDS = L or Open

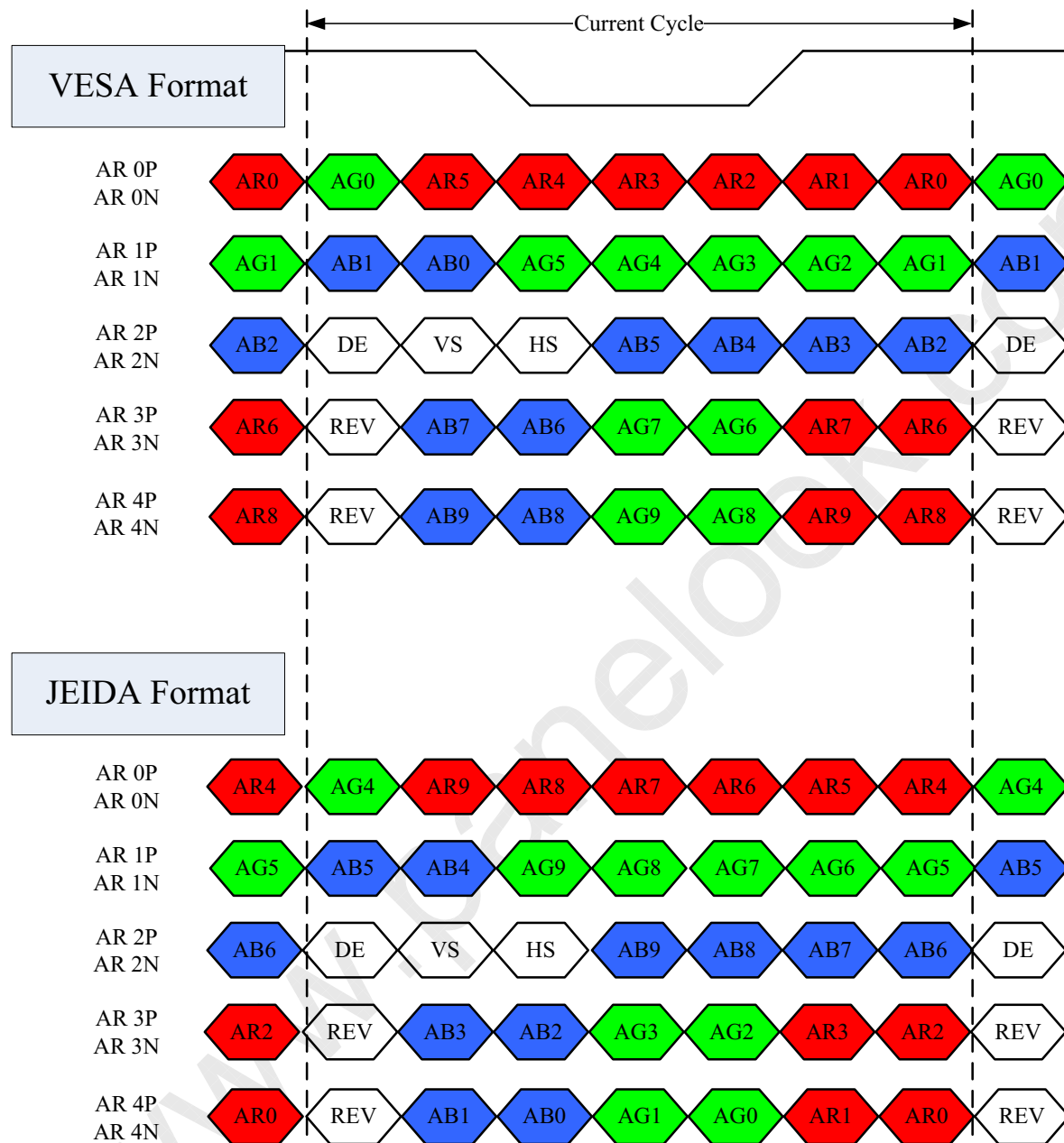

AR0~AR9: First Pixel R Data (9; MSB, 0; LSB)

AG0~AG9: First Pixel G Data (9; MSB, 0; LSB)

AB0~AB9: First Pixel B Data (9; MSB, 0; LSB)

DE : Data enable signal

DCLK : Data clock signal

RSV : Reserved

5.3 COLOR DATA INPUT ASSIGNMENT

The brightness of each primary color (red, green and blue) is based on the 10-bit gray scale data input for the color. The higher the binary input, the brighter the color. The table below provides the assignment of the color versus data input.

Color		Data Signal																											
		Red										Green										Blue							
		R9	R8	R7	R6	R5	R4	R3	R2	R1	R0	G9	G8	G7	G6	G5	G4	G3	G2	G1	G0	B9	B8	B7	B6	B5	B4	B3	B2
Basic Colors	Black	0	0	0	0	0	0	0	0	0	0	0	0	0	0	0	0	0	0	0	0	0	0	0	0	0	0	0	0
	Red	1	1	1	1	1	1	1	1	1	0	0	0	0	0	0	0	0	0	0	0	0	0	0	0	0	0	0	0
	Green	0	0	0	0	0	0	0	0	0	0	1	1	1	1	1	1	1	1	1	1	0	0	0	0	0	0	0	0
	Blue	0	0	0	0	0	0	0	0	0	0	0	0	0	0	0	0	0	0	0	1	1	1	1	1	1	1	1	1
	Cyan	0	0	0	0	0	0	0	0	0	0	1	1	1	1	1	1	1	1	1	1	1	1	1	1	1	1	1	1
	Magenta	1	1	1	1	1	1	1	1	1	0	0	0	0	0	0	0	0	0	0	1	1	1	1	1	1	1	1	1
	Yellow	1	1	1	1	1	1	1	1	1	1	1	1	1	1	1	1	1	1	1	0	0	0	0	0	0	0	0	0
	White	1	1	1	1	1	1	1	1	1	1	1	1	1	1	1	1	1	1	1	1	1	1	1	1	1	1	1	1
Gray Scale Of Red	Red (0) / Dark	0	0	0	0	0	0	0	0	0	0	0	0	0	0	0	0	0	0	0	0	0	0	0	0	0	0	0	
	Red (1)	0	0	0	0	0	0	0	0	1	0	0	0	0	0	0	0	0	0	0	0	0	0	0	0	0	0	0	
	Red (2)	0	0	0	0	0	0	0	1	0	0	0	0	0	0	0	0	0	0	0	0	0	0	0	0	0	0	0	
	:	:	:	:	:	:	:	:	:	:	:	:	:	:	:	:	:	:	:	:	:	:	:	:	:	:	:	:	
	:	:	:	:	:	:	:	:	:	:	:	:	:	:	:	:	:	:	:	:	:	:	:	:	:	:	:	:	
	Red (1021)	1	1	1	1	1	1	1	0	1	0	0	0	0	0	0	0	0	0	0	0	0	0	0	0	0	0	0	
	Red (1022)	1	1	1	1	1	1	1	1	0	0	0	0	0	0	0	0	0	0	0	0	0	0	0	0	0	0	0	
	Red (1023)	1	1	1	1	1	1	1	1	1	0	0	0	0	0	0	0	0	0	0	0	0	0	0	0	0	0	0	
Gray Scale Of Green	Green (0) / Dark	0	0	0	0	0	0	0	0	0	0	0	0	0	0	0	0	0	0	0	0	0	0	0	0	0	0	0	
	Green (1)	0	0	0	0	0	0	0	0	0	0	0	0	0	0	0	0	0	0	1	0	0	0	0	0	0	0	0	
	Green (2)	0	0	0	0	0	0	0	0	0	0	0	0	0	0	0	0	0	1	0	0	0	0	0	0	0	0	0	
	:	:	:	:	:	:	:	:	:	:	:	:	:	:	:	:	:	:	:	:	:	:	:	:	:	:	:	:	
	:	:	:	:	:	:	:	:	:	:	:	:	:	:	:	:	:	:	:	:	:	:	:	:	:	:	:	:	
	Green (1021)	0	0	0	0	0	0	0	0	0	1	1	1	1	1	1	1	1	0	1	0	0	0	0	0	0	0	0	
	Green (1022)	0	0	0	0	0	0	0	0	0	1	1	1	1	1	1	1	1	0	0	0	0	0	0	0	0	0	0	
	Green (1023)	0	0	0	0	0	0	0	0	0	1	1	1	1	1	1	1	1	1	0	0	0	0	0	0	0	0	0	
Gray Scale Of Blue	Blue (0) / Dark	0	0	0	0	0	0	0	0	0	0	0	0	0	0	0	0	0	0	0	0	0	0	0	0	0	0	0	
	Blue (1)	0	0	0	0	0	0	0	0	0	0	0	0	0	0	0	0	0	0	0	0	0	0	0	0	0	0	1	
	Blue (2)	0	0	0	0	0	0	0	0	0	0	0	0	0	0	0	0	0	0	0	0	0	0	0	0	0	1	0	
	:	:	:	:	:	:	:	:	:	:	:	:	:	:	:	:	:	:	:	:	:	:	:	:	:	:	:	:	
	:	:	:	:	:	:	:	:	:	:	:	:	:	:	:	:	:	:	:	:	:	:	:	:	:	:	:	:	

Blue (1021)	0	0	0	0	0	0	0	0	0	0	0	0	0	0	0	0	0	0	0	0	1	1	1	1	1	1	1	1	0	1
Blue (1022)	0	0	0	0	0	0	0	0	0	0	0	0	0	0	0	0	0	0	0	0	1	1	1	1	1	1	1	1	1	0
Blue (1023)	0	0	0	0	0	0	0	0	0	0	0	0	0	0	0	0	0	0	0	0	1	1	1	1	1	1	1	1	1	1

Note (1) 0: Low Level Voltage, 1: High Level Voltage

5.4 FLICKER (Vcom) ADJUSTMENT

(1) Adjustment Pattern:

Column inversion pattern was shown as below. If customer need below pattern, please directly contact with Account FAE.

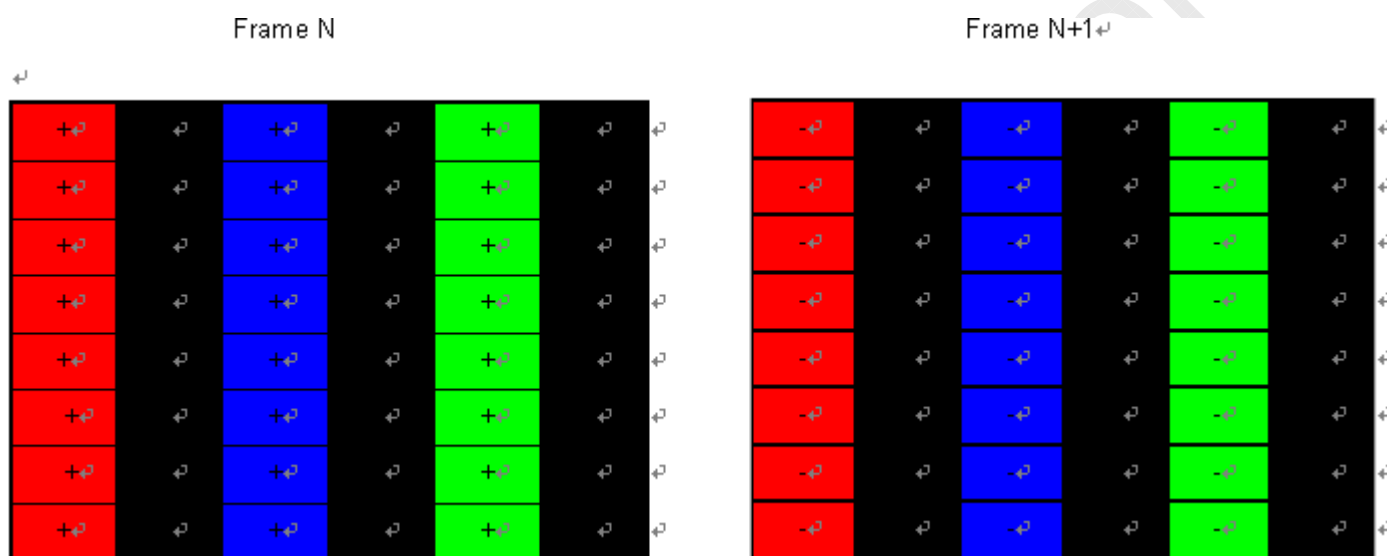

(2) Adjustment method: (Digital V-com)

Programmable memory IC is used for Digital V-com adjustment in this model. CMI provide Auto Vcom tools to adjust Digital V-com. The detail connection and setting instruction, please directly contact with Account FAE or refer CMI Auto V-com adjustment OI. Below items is suggested to be ready before Digital V-com adjustment in customer LCM line.

6. INTERFACE TIMING

6.1 INPUT SIGNAL TIMING SPECIFICATIONS

($T_a = 25 \pm 2 \text{ }^\circ\text{C}$)

The input signal timing specifications are shown as the following table and timing diagram.

Signal	Item	Symbol	Min.	Typ.	Max.	Unit	Note
LVDS Receiver Clock	Frequency	F_{clkin} ($=1/TC$)	60	74.25	80	MHz	
	Input cycle to cycle jitter	T_{rcj}	—	—	200	ps	(3)
	Spread spectrum modulation range	$F_{\text{clkin_mod}}$	$F_{\text{clkin}}-2\%$	—	$F_{\text{clkin}}+2\%$	MHz	(4)
	Spread spectrum modulation frequency	F_{SSM}			200	KHz	
LVDS Receiver Data	Setup Time	T_{lvsu}	600	—	—	ps	(5)
	Hold Time	T_{lvhd}	600	—	—	ps	
Vertical Active Display Term	Frame Rate	F_{r5}	—	100	—	Hz	(6)
		F_{r6}	—	120	—	Hz	
	Total	T_{v}	1115	1125	1135	Th	$T_{\text{v}}=T_{\text{vd}}+T_{\text{vb}}$
	Display	T_{vd}	1080	1080	1080	Th	—
	Blank	T_{vb}	35	45	55	Th	—
'Horizontal Active Display Term	Total	T_{h}	540	550	575	T_{c}	$T_{\text{h}}=T_{\text{hd}}+T_{\text{hb}}$
	Display	T_{hd}	480	480	480	T_{c}	—
	Blank	T_{hb}	60	70	95	T_{c}	—

Note (1) Since the module is operated in DE only mode, Hsync and Vsync input signals should be set to low logic level. Otherwise, this module would operate abnormally.

Note (2) Please make sure the range of pixel clock has follow the below equation:

$$F_{\text{clkin(max)}} \geq F_{\text{r6}} \times T_{\text{v}} \times T_{\text{h}}$$

$$F_{\text{r5}} \times T_{\text{v}} \times T_{\text{h}} \geq F_{\text{clkin(min)}}$$

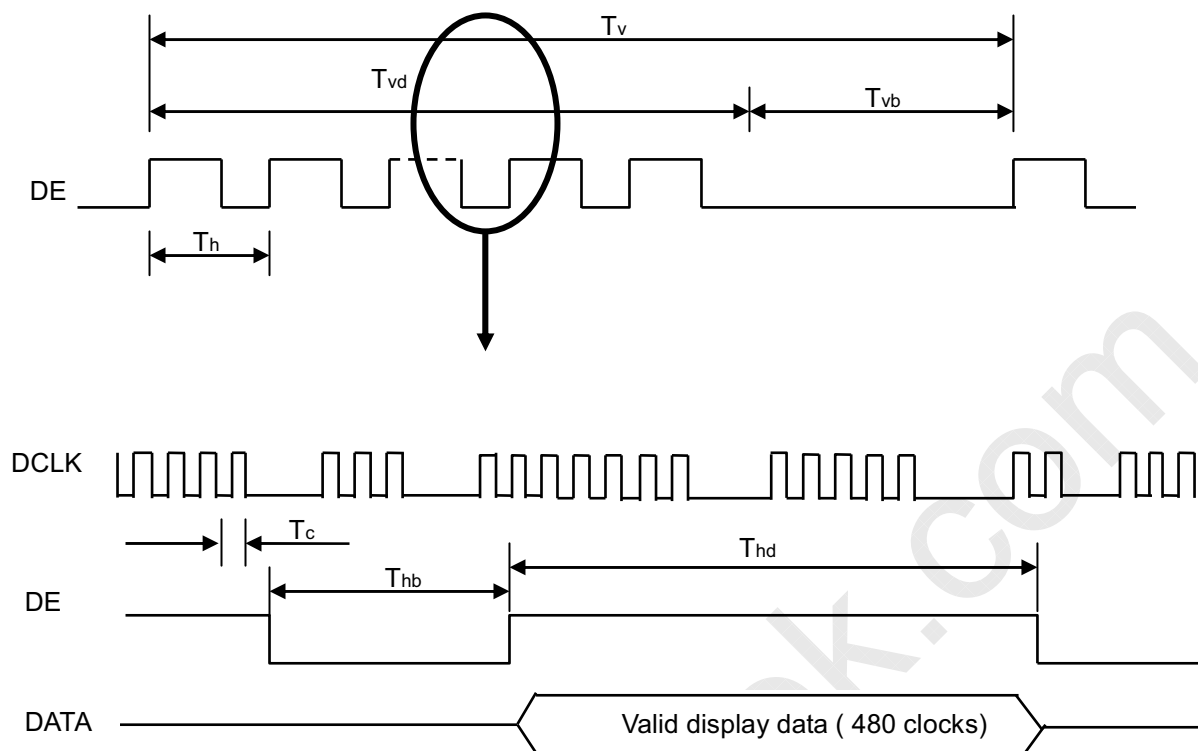

Note (3) The input clock cycle-to-cycle jitter is defined as below figures. $Trcl = |T_1 - T_2|$

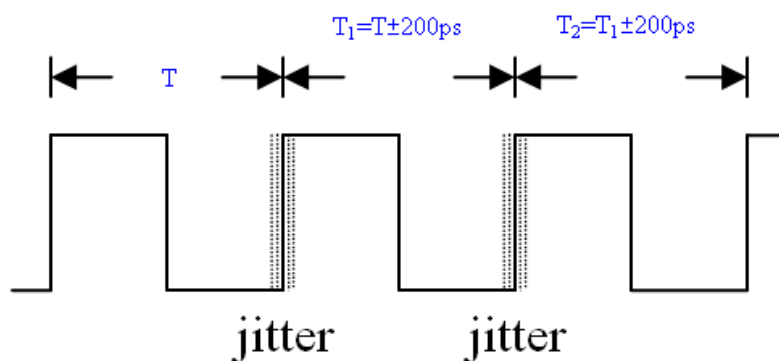

Note (4) The SSCG (Spread spectrum clock generator) is defined as below figures.

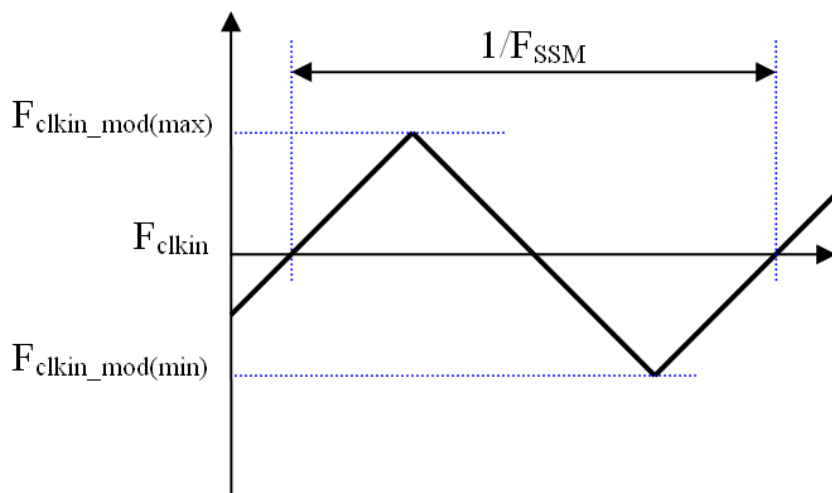

Note (5) The LVDS timing diagram and setup/hold time is defined and showing as the following figures.

LVDS RECEIVER INTERFACE TIMING DIAGRAM

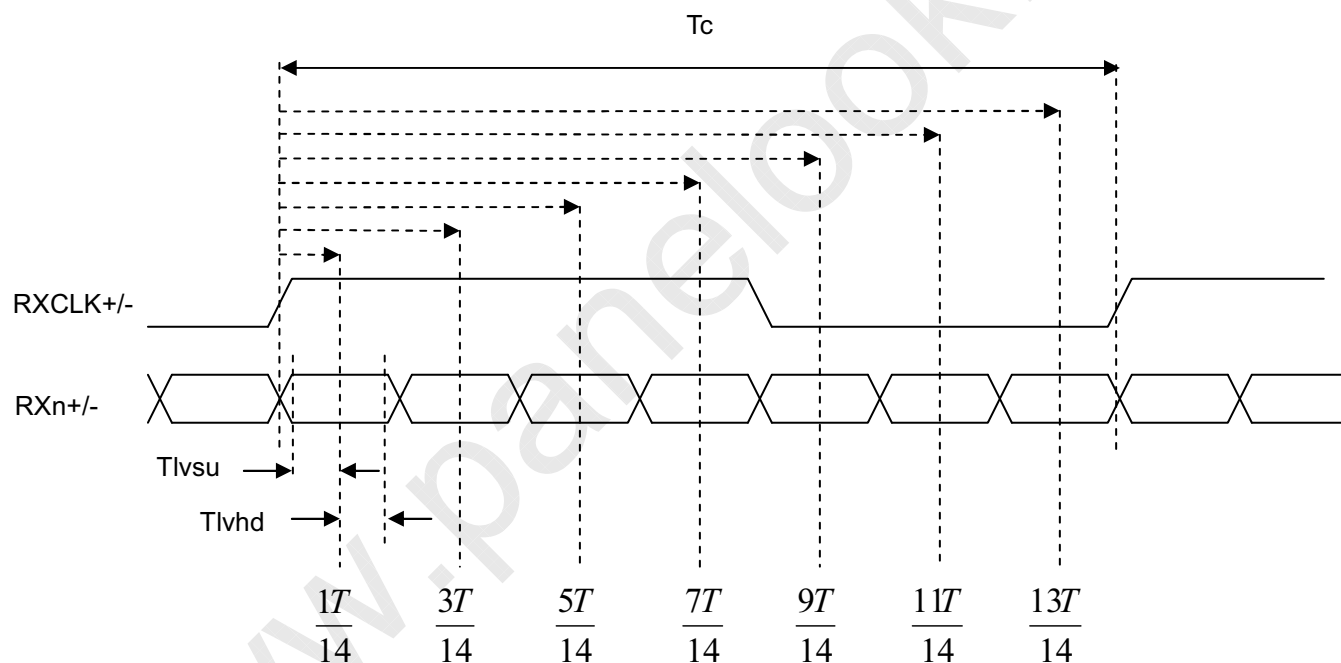

6.2 POWER ON/OFF SEQUENCE

($T_a = 25 \pm 2 \text{ }^\circ\text{C}$)

To prevent a latch-up or DC operation of LCD module, the power on/off sequence should be as the diagram below.

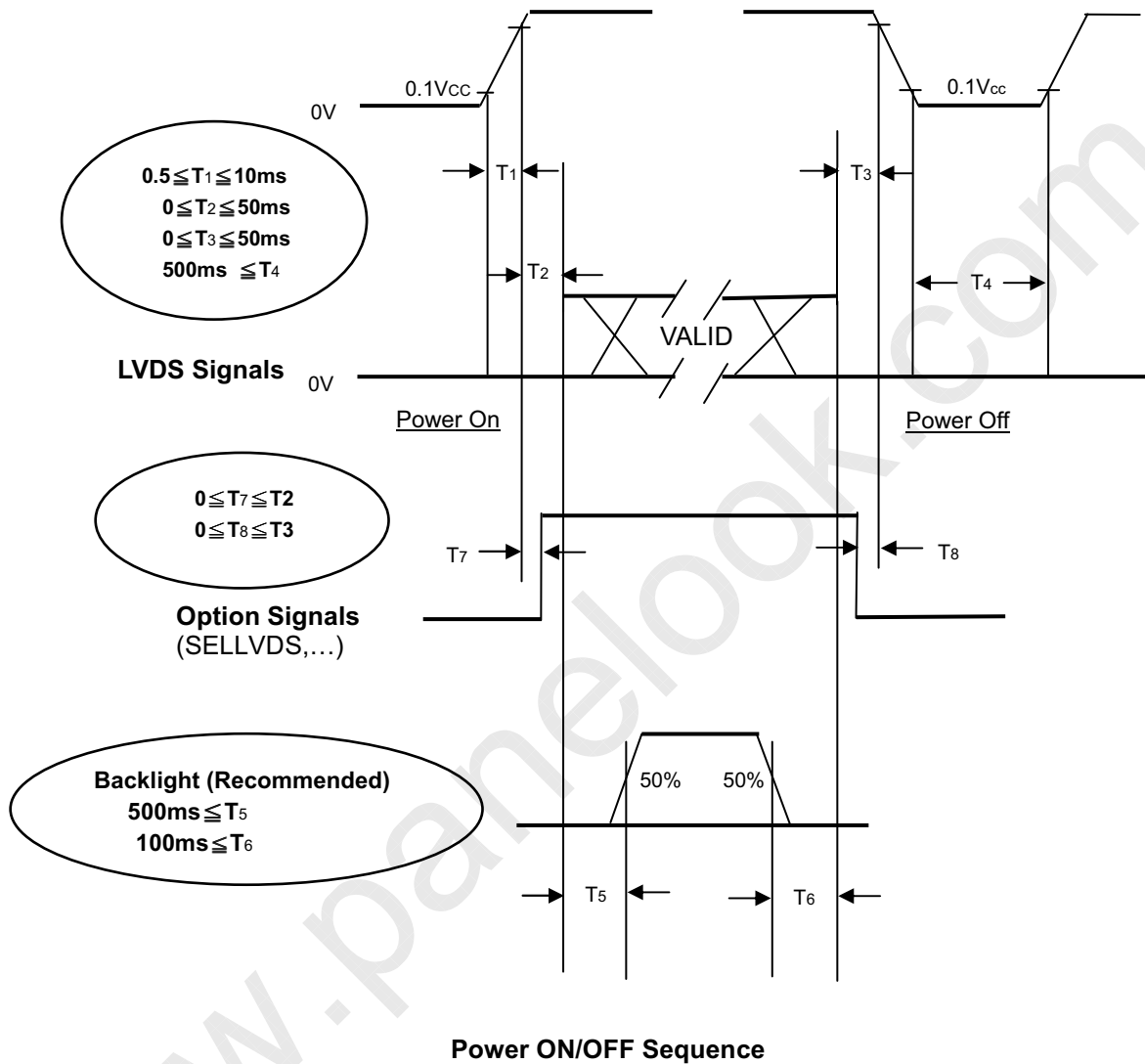

Note (1) The supply voltage of the external system for the module input should follow the definition of Vcc.

Note (2) Apply the lamp voltage within the LCD operation range. When the backlight turns on before the LCD operation or the LCD turns off before the backlight turns off, the display may momentarily become abnormal screen.

Note (3) In case of Vcc is in off level, please keep the level of input signals on the low or high impedance. If $T_2 < 0$, that maybe cause electrical overstress failure.

Note (4) T4 should be measured after the module has been fully discharged between power off and on period.

Note (5) Interface signal shall not be kept at high impedance when the power is on.

7. OPTICAL CHARACTERISTICS

7.1 TEST CONDITIONS

Item	Symbol	Value	Unit
Ambient Temperature	Ta	25±2	°C
Ambient Humidity	Ha	50±10	%RH
Supply Voltage	V _{CC}	12.0	V
Input Signal	According to typical value in "3. ELECTRICAL CHARACTERISTICS"		
Vertical Frame Rate	Fr	120	Hz

The LCD module should be stabilized at given temperature for 1 hour to avoid abrupt temperature change during measuring in a windless room.

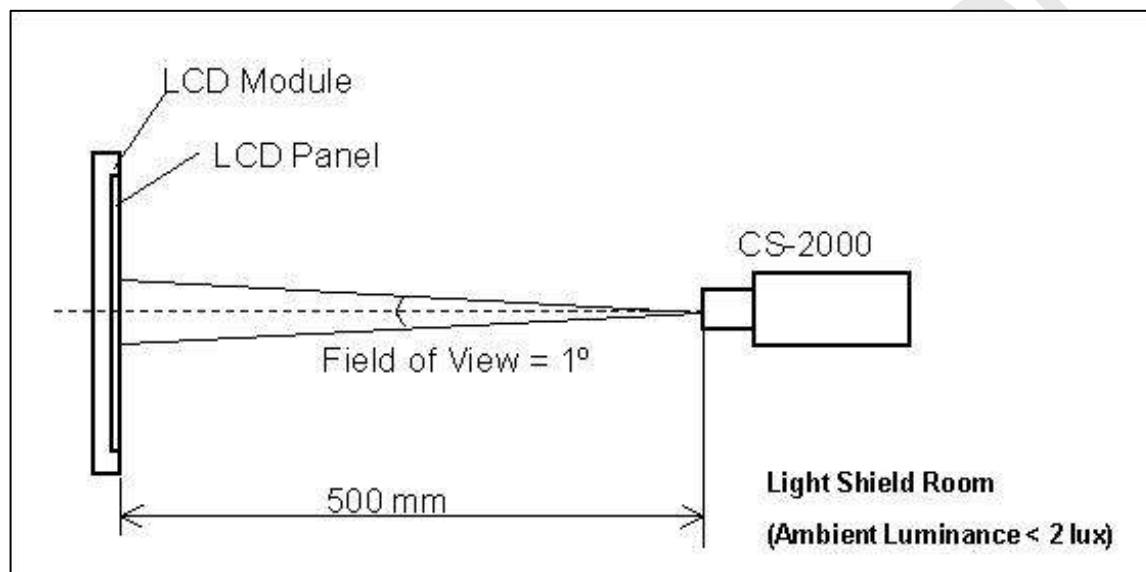

7.2 OPTICAL SPECIFICATIONS

The relative measurement methods of optical characteristics are shown as below. The following items should be measured under the test conditions described in 7.1 and stable environment shown in 7.1.

Item	Symbol	Condition	Min.	Typ.	Max.	Unit	Note
Color Chromaticity	Red	Rcx	Typ-0.03	0.655	Typ+0.03	-	(0)
		Rcy		0.328		-	
	Green	Gcx		0.266		-	
		Gcy		0.583		-	
	Blue	Bcx		0.131		-	
		Bcy		0.116		-	
	White	Wcx		0.301		-	
		Wcy		0.358		-	
Center Transmittance	T%	$\theta_x=0^\circ, \theta_y=0^\circ$	-	5.5	-	%	(1),(6)
Contrast Ratio	CR	with CMI module	4000	6000	-	-	(1),(3)
Response Time	Gray to gray	$\theta_x=0^\circ, \theta_y=0^\circ$ with CMI Module	-	6.5	13	ms	(1),(4)
White Variation	δW	$\theta_x=0^\circ, \theta_y=0^\circ$ with CMI module	-	-	1.3	-	(1),(5)
Viewing Angle	Horizontal	θ_{x+}	-	88	-	Deg.	(1),(2)
		θ_{x-}	-	88	-		
	Vertical	θ_{y+}	-	88	-		
		θ_{y-}	-	88	-		

Note (0) Light source is the standard light source “C” which is defined by CIE and driving voltages are based on suitable gamma voltages. The calculating method is as following :

Measure Module' s and BLU' s spectrums. W, R, G, B are with signal input. BLU(for V546H1-LH1) is supplied by CMO.

Calculate cell' s spectrum.

Calculate cell' s chromaticity by using the spectrum of standard light source “C”

Note (1) Light source is the BLU which is supplied by CMO and driving voltages are based on suitable gamma voltages.

Note (2) Definition of Viewing Angle (x, y):

Viewing angles are measured by Autronic Conoscope Cono-80

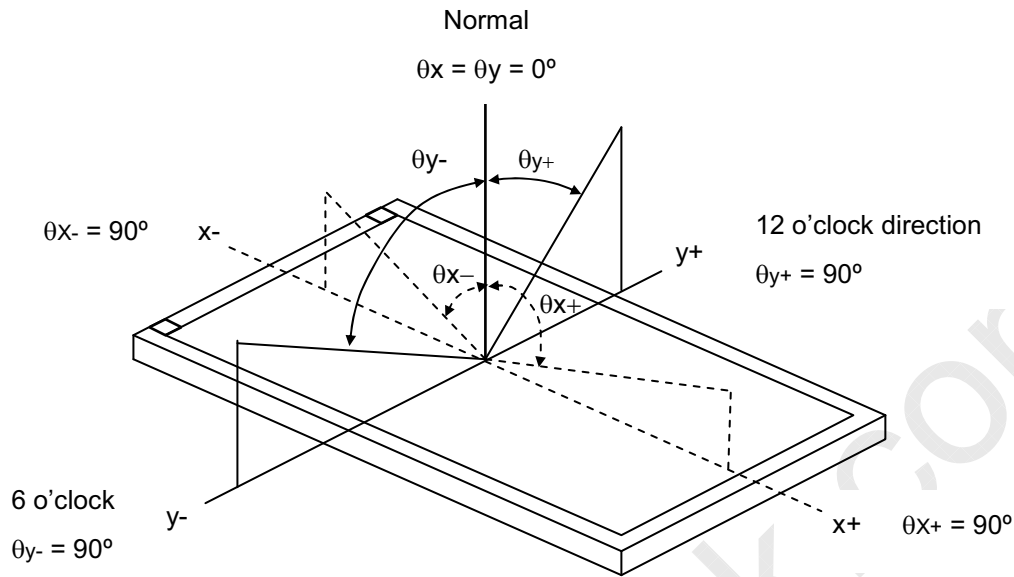

Note (3) Definition of Contrast Ratio (CR):

The contrast ratio can be calculated by the following expression.

$$\text{Contrast Ratio (CR)} = \frac{\text{Surface Luminance of L255}}{\text{Surface Luminance of L0}}$$

L255: Luminance of gray level 255

L 0: Luminance of gray level 0

CR = CR (5), where CR (X) is corresponding to the Contrast Ratio of the point X at the figure in Note (6).

Note (4) Definition of Gray-to-Gray Switching Time:

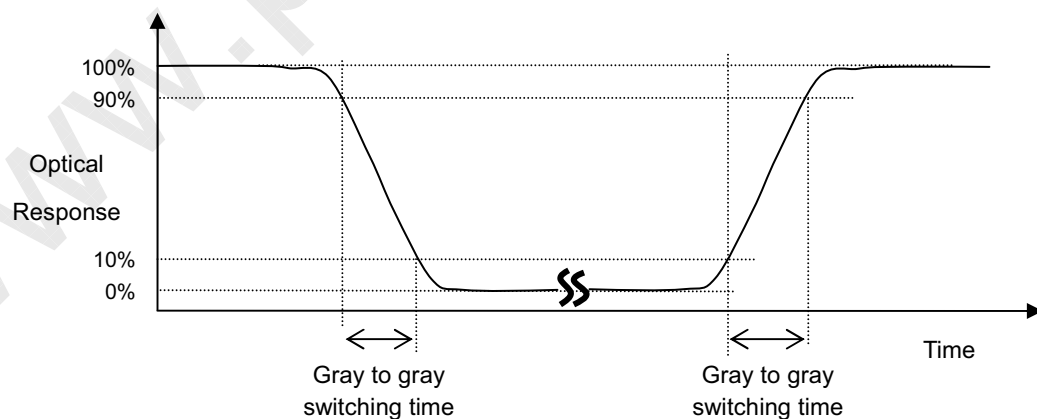

The driving signal means the signal of gray level 0, 124, 252, 380, 508, 636, 764, 892 and 1023.

Gray to gray average time means the average switching time of gray level 0, 124, 252, 380, 508, 636, 764, 892 and 1023 to each other.

Note (5) Definition of White Variation (δW):

Measure the luminance of gray level 255 at 5 points

$$\delta W = \text{Maximum [L (1), L (2), L (3), L (4), L (5)]} / \text{Minimum [L (1), L (2), L (3), L (4), L (5)]}$$

Note (6) Definition of White Variation (δW):

Measure the luminance of gray level 255 at 5 points

$$\delta W = \text{Maximum [L (1), L (2), L (3), L (4), L (5)]} / \text{Minimum [L (1), L (2), L (3), L (4), L (5)]}$$

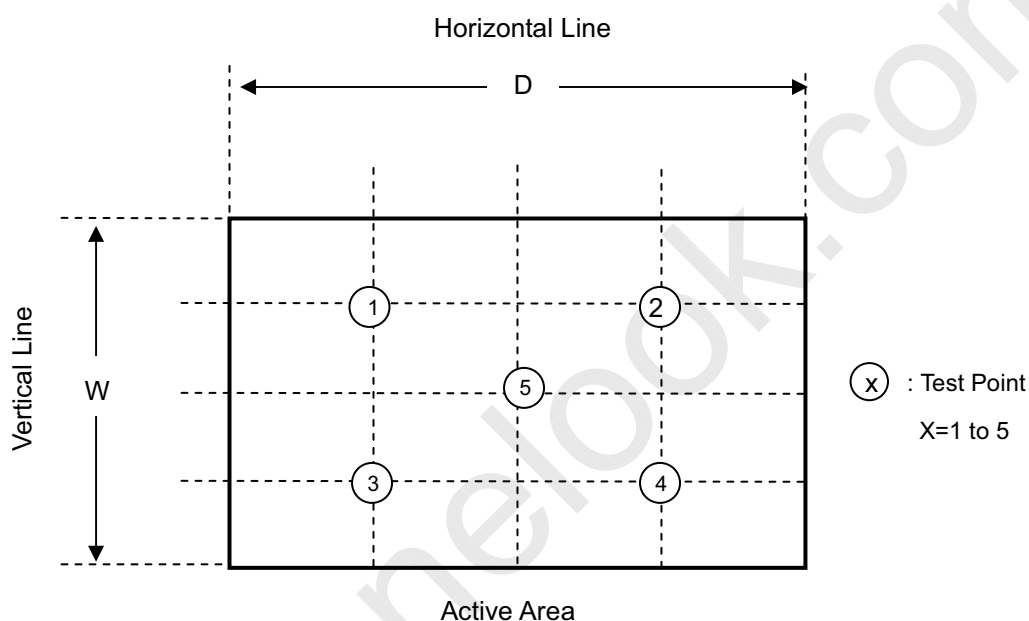

Note (7) Definition of Transmittance (T%) :

Measure the luminance of gray level 255 at center point of LCD module.

$$\text{Transmittance (T\%)} = \frac{\text{Luminance of LCD module}}{\text{Luminance of backligh unit}} \times 100\% \text{ PRECAUTIONS}$$

8. PRECAUTIONS**8.1 ASSEMBLY AND HANDLING PRECAUTIONS**

- [1] Do not apply rough force such as bending or twisting to the module during assembly.
- [2] It is recommended to assemble or to install a module into the user's system in clean working areas. The dust and oil may cause electrical short or worsen the polarizer.
- [3] Do not apply pressure or impulse to the module to prevent the damage of LCD panel and Backlight.
- [4] Always follow the correct power-on sequence when the LCD module is turned on. This can prevent the damage and latch-up of the CMOS LSI chips.
- [5] The distance between COF edge and rib of BLU must bigger than 5mm. This can prevent the damage of COF when assemble the module.
- [6] Do not design sharp-pointed structure / parting line / tooling gate on the COF position of plastic parts, because the burr will scrape the COF.
- [7] If COF would bended to assemble in the module. Do not put the IC location on the bending corner of COF.
- [8] The gap between COF IC and any structure of BLU must bigger than 2mm. This can prevent the damage of COF IC
- [9] Bezel opening must have no burr. Burr will scrape the panel surface.
- [10] Bezel of module and bezel of set can not press or touch the panel surface. It will make light leakage or scrape.
- [11] When module used FFC / FPC, but no FFC / FPC to be attached in the open cell. Customer can refer the FFC / FPC drawing and buy it by self.
- [12] The gap between Panel and any structure of Bezel must bigger than 2mm. This can prevent the damage of Panel.
- [13] Do not plug in or pull out the I/F connector while the module is in operation.
- [14] Do not disassemble the module.
- [15] Use a soft dry cloth without chemicals for cleaning, because the surface of polarizer is very soft and easily scratched.
- [16] Moisture can easily penetrate into LCD module and may cause the damage during operation.
- [17] When storing modules as spares for a long time, the following precaution is necessary.
 - [17.1] Do not leave the module in high temperature, and high humidity for a long time. It is highly recommended to store the module with temperature from 0 to 35°C at normal humidity without condensation.
 - [17.2] The module shall be stored in dark place. Do not store the TFT-LCD module in direct sunlight or fluorescent light.
- [18] When ambient temperature is lower than 10°C, the display quality might be reduced.

8.2 SAFETY PRECAUTIONS

- [1] The startup voltage of a Backlight is approximately 1000 Volts. It may cause an electrical shock while assembling with the inverter. Do not disassemble the module or insert anything into the Backlight unit.
- [2] If the liquid crystal material leaks from the panel, it should be kept away from the eyes or mouth. In case of contact with hands, skin or clothes, it has to be washed away thoroughly with soap.
- [3] After the module's end of life, it is not harmful in case of normal operation and storage.

9. DEFINITION OF LABELS

9.1 OPEN CELL LABEL

The barcode nameplate is pasted on each open cell as illustration for CMI internal control.

V546HK2-PE1 Rev.XX



XXXXXXXXXXXXXXXXXX

Made in China

9.2 CARTON LABEL

The barcode nameplate is pasted on each box as illustration, and its definitions are as following explanation.



- (a) Model Name: V546HK2-PE1
- (b) Carton ID: CMI internal control
- (c) Quantities: 6 pcs

10 . PACKAGING

10.1 packing specifications

- (1) 6 LCD TV Panels / 1 Box
- (2) Box dimensions : 1454 (L) X 994 (W) X 210 (H)
- (3) Weight : approximately 42Kg (6 panels per box)

9.2 packing Method

Figures 9-1 and 9-2 are the packing method

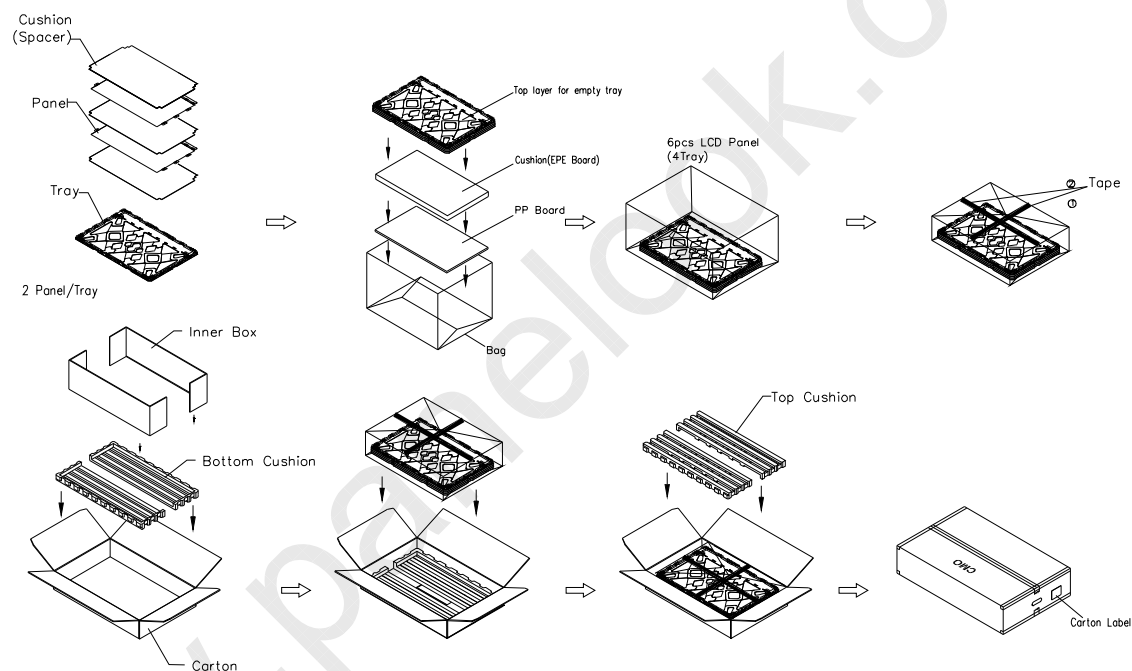
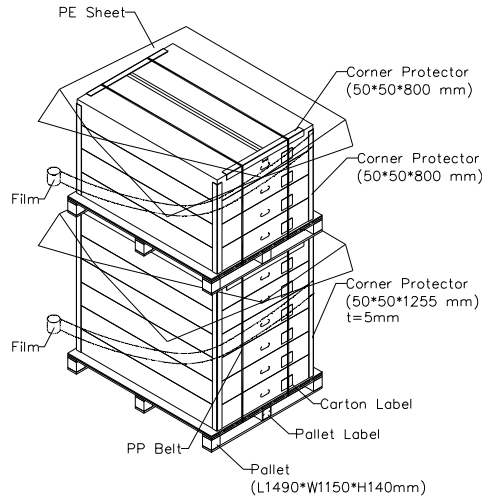
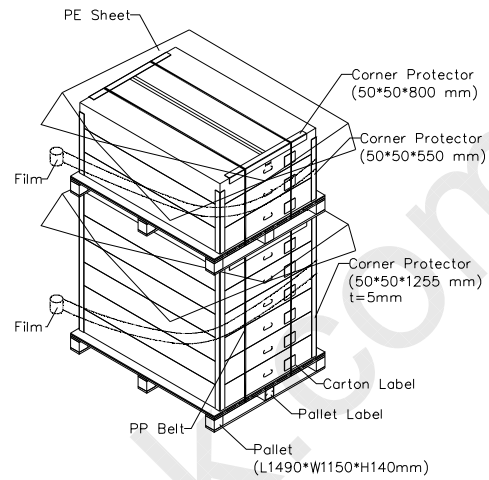

Figure.9-1 packing method

Sea / Land Transportation
(40ft HQ Container)



Sea / Land Transportation



Air Transportation

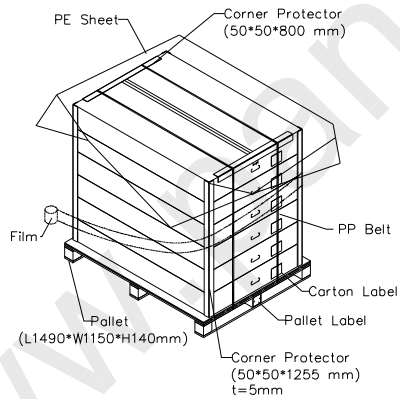
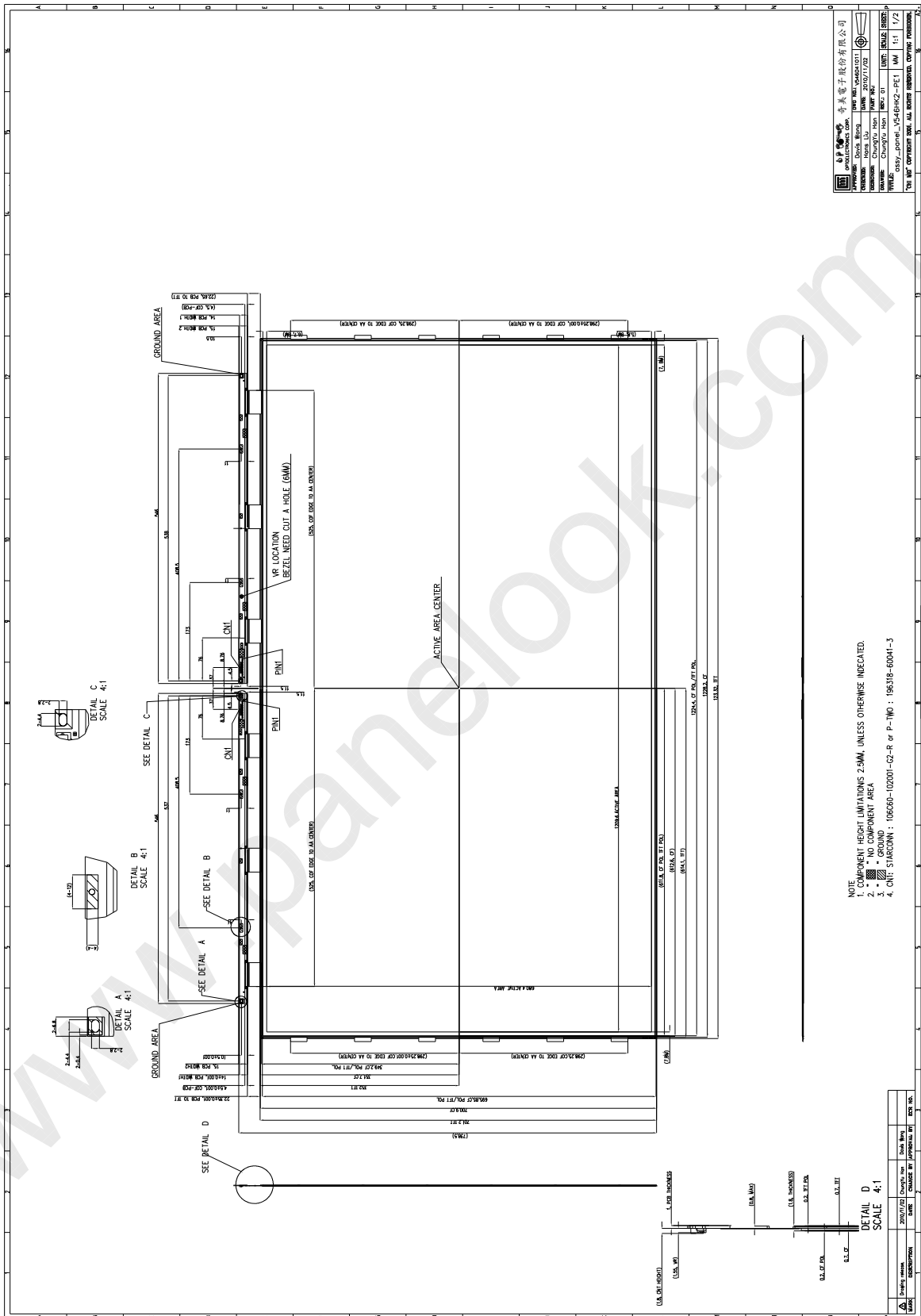

Figure.9-2 packing method

11. MECHANICAL CHARACTERISTIC



PRODUCT SPECIFICATION

