

- Tentative Specification
- Preliminary Specification
- Approval Specification

MODEL NO.: V546HK3

SUFFIX: PS5

Ver.C7

Customer:	
APPROVED BY	SIGNATURE
<u>Name / Title</u> _____	
Note	

Please return 1 copy for your confirmation with your signature and comments.	

Approved By	Checked By	Prepared By
Chao-Chun Chung	Ken Wu	YI-CHEN Chiang

CONTENTS

REVISION HISTORY.....	4
1. GENERAL DESCRIPTION	5
1.1 OVERVIEW	5
1.2 FEATURES.....	5
1.3 MECHANICAL SPECIFICATIONS	5
2. ABSOLUTE MAXIMUM RATINGS	6
2.1 ABSOLUTE RATINGS OF ENVIRONMENT	6
2.2 ELECTRICAL ABSOLUTE RATINGS(OPEN CELL).....	7
3. ELECTRICAL CHARACTERISTICS	8
3.1 TFT LCD Module.....	8
4. BLOCK DIAGRAM OF INTERFACE	11
4.1 TFT LCD MODULE	11
5. INPUT TERMINAL PIN ASSIGNMENT	12
5.1 TFT LCD OPEN CELL	12
5.2 LVDS INTERFACE	18
5.3 COLOR DATA INPUT ASSIGNMENT	20
6. INTERFACE TIMING	22
6.1 INPUT SIGNAL TIMING SPECIFICATIONS	22
6.1.1 Timing spec for Frame Rate = 50Hz	22
6.1.2 Timing spec for Frame Rate = 60Hz	23
6.2 POWER ON/OFF SEQUENCE (Ta = 25 ± 2 °C).....	27
6.2.1 POWER ON/OFF SEQUENCE	27
6.2.2 2D/3D MODE CHANGE 2D to 3D SIGNAL SEQUENCE WITHOUT VCC TURN OFF AND TURN ON	28
7. OPTICAL CHARACTERISTICS	29
7.1 TEST CONDITIONS.....	29
7.2 OPTICAL SPECIFICATIONS	30
8. PRECAUTIONS.....	34
8.1 ASSEMBLY AND HANDLING PRECAUTIONS	34

8.2 SAFETY PRECAUTIONS	34
9. DEFINITION OF LABELS.....	35
9.1 OPEN CELL LABEL	35
9.2 CARTON LABEL	37
10. Packaging	38
10.1 PACKING SPECIFICATIONS.....	38
10.2 PACKING METHOD.....	38
11. MECHANICAL CHARACTERISTIC.....	40
Appendix A.....	42

REVISION HISTORY

Version	Date	Page (New)	Section	Description
C7(2.0)	Mar. 05,12	all	all	Approval Specification Ver 2.0 was first issued.

1. GENERAL DESCRIPTION

1.1 OVERVIEW

V546HK3-PS5 is a 54.6" TFT Liquid Crystal Display product with driver ICs and 2ch-LVDS interface. This product supports 1920 x 1080 HDTV format and can display true 16.7M colors (8-bit). The backlight unit is not built in.

1.2 FEATURES

CHARACTERISTICS ITEMS	SPECIFICATIONS
Screen Diagonal [in]	54.6
Pixels [lines]	1920 x 1080
Active Area [mm]	1209.6(H) x 680.4(V) (54.6" diagonal)
Sub-Pixel Pitch [mm]	0.21(H) x 0.63(V)
Pixel Arrangement	RGB vertical stripe
Weight [g]	3450
Physical Size [mm]	1233.2(W) x 701.2(H) x 1.80(D) Typ
Display Mode	Transmissive mode / Normally black
Contrast Ratio	5000:1 Typ. (Typical value measured at CMI's module)
Glass thickness (Array / CF) [mm]	0.7 / 0.7
Viewing Angle (CR>20)	+88/-88(H),+88/-88(V) Typ. (Typical value measured at CMI's module)
Color Chromaticity	R=(0.658, 0.322) G=(0.266, 0.583) B=(0.134, 0.103) W=(0.300, 0.349) * Please refer to "color chromaticity" on 7.2
Cell Transparency [%]	6.4%Typ. (Typical value measured at CMI's module)
Polarizer Surface Treatment	Anti-Glare coating (Haze 3.5%),Hardness 3H

1.3 MECHANICAL SPECIFICATIONS

Item	Min.	Typ.	Max.	Unit	Note
Weight	-	3450	-	g	-
I/F connector mounting position	The mounting inclination of the connector makes the screen center within $\pm 0.5\text{mm}$ as the horizontal.				(2)

Note (1) Please refer to the attached drawings for more information of front and back outline dimensions.

Note (2) Connector mounting position

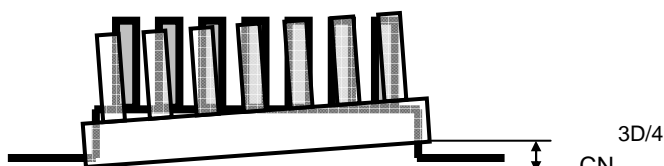

2. ABSOLUTE MAXIMUM RATINGS

2.1 ABSOLUTE RATINGS OF ENVIRONMENT

Item	Symbol	Value		Unit	Note
		Min.	Max.		
Storage Temperature	TST	-20	+60	°C	(1) With CMI Module
Operating Ambient Temperature	TOP	0	50	°C	(1), (2) With CMI Module

Note (1) Temperature and relative humidity range is shown in the figure below.

- (a) 90 %RH Max. ($T_a \leq 40\text{ }^\circ\text{C}$).
- (b) Wet-bulb temperature should be 39 °C Max. ($T_a > 40\text{ }^\circ\text{C}$).
- (c) No condensation.

Note (2) The maximum operating temperature is based on the test condition that the surface temperature of display area is less than or equal to 65 °C with LCD module alone in a temperature controlled chamber. Thermal management should be considered in final product design to prevent the surface temperature of display area from being over 65 °C. The range of operating temperature may degrade in case of improper thermal management in final product design.

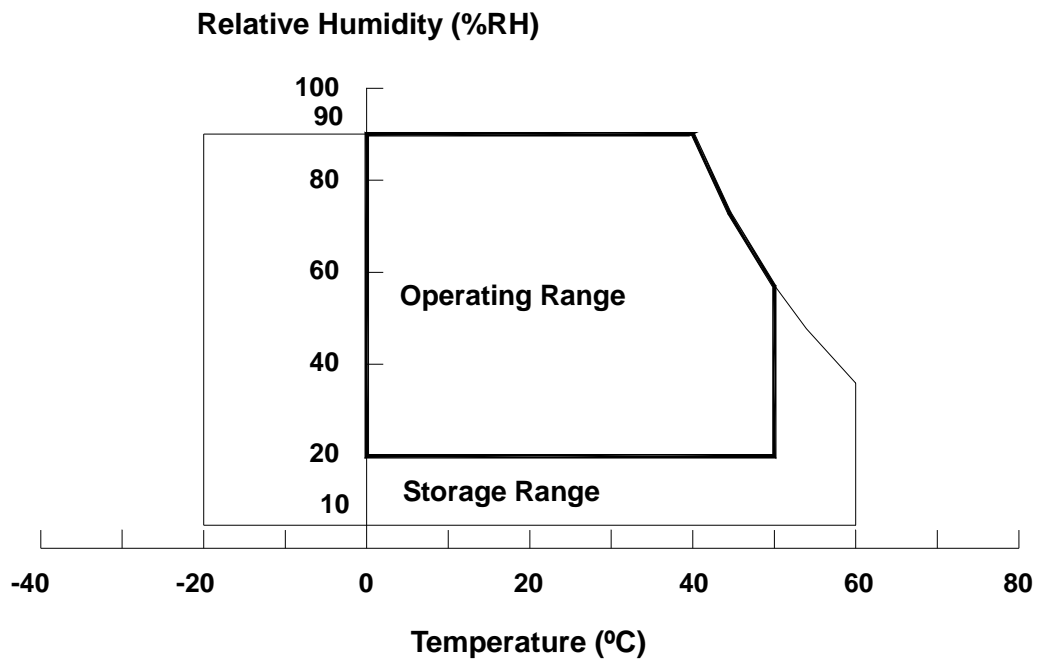

2.2 ELECTRICAL ABSOLUTE RATINGS(OPEN CELL)

Storage Condition: With shipping package.

Storage temperature range: 25 ± 5 °C

Storage humidity range: $50\pm 10\%$ RH

Shelf life: a month

3. ELECTRICAL CHARACTERISTICS

3.1 TFT LCD Module

(Ta = 25 ± 2 °C)

Parameter		Symbol	Value			Unit	Note
			Min.	Typ.	Max.		
Power Supply Voltage		V _{CC}	10.8	12	13.2	V	(1)
Rush Current		I _{RUSH}	—	—	2.67	A	(2)
Power Consumption	White Pattern	—	—	9.36	11.52	W	(3)
	Horizontal Stripe	—	—	19.92	24	W	
	Black Pattern	—	—	8.88	10.8	W	
Power Supply Current	White Pattern	—	—	0.78	0.96	A	
	Horizontal Stripe	—	—	1.66	2	A	
	Black Pattern	—	—	0.74	0.9	A	
LVDS interface	Differential Input High Threshold Voltage	V _{LVTH}	+100	—	—	mV	(4)
	Differential Input Low Threshold Voltage	V _{LVTL}	—	—	-100	mV	
	Common Input Voltage	V _{CM}	1.0	1.2	1.4	V	
	Differential input voltage (single-end)	V _{ID}	200	—	600	mV	
	Terminating Resistor	R _T	—	100	—	ohm	
CMIS interface	Input High Threshold Voltage	V _{IH}	2.7	—	3.3	V	
	Input Low Threshold Voltage	V _{IL}	0	—	0.7	V	

Note (1) The module should be always operated within the above ranges.

Note (2) Measurement condition:

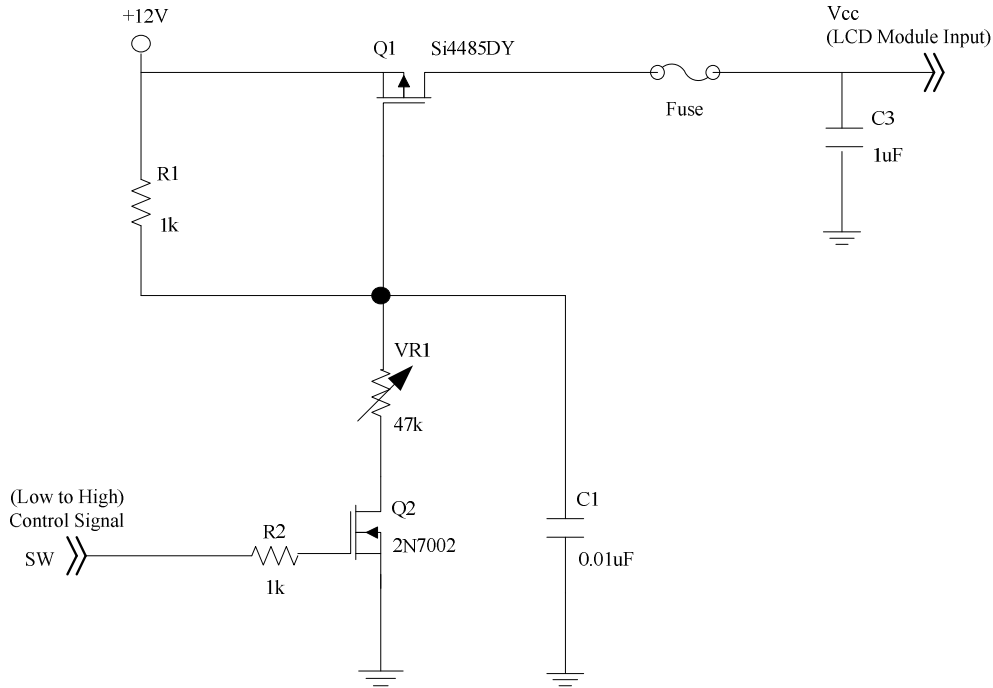

Vcc rising time is 470us

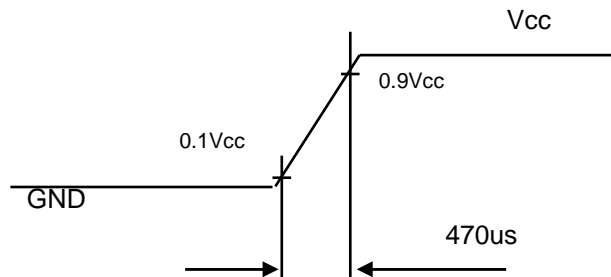

Note (3) The specified power consumption and power supply current is under the conditions at $V_{cc} = 12\text{ V}$, $T_a = 25 \pm 2\text{ }^\circ\text{C}$, $f_v = 60\text{ Hz}$, whereas a power dissipation check pattern below is displayed.

a. White Pattern

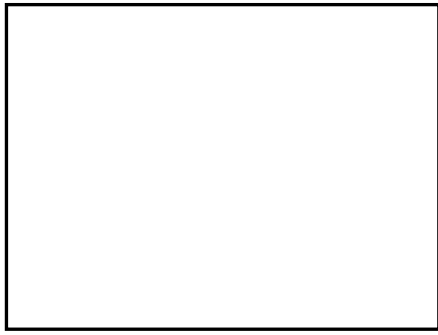

Active Area

b. Black Pattern



Active Area

c. Horizontal Pattern

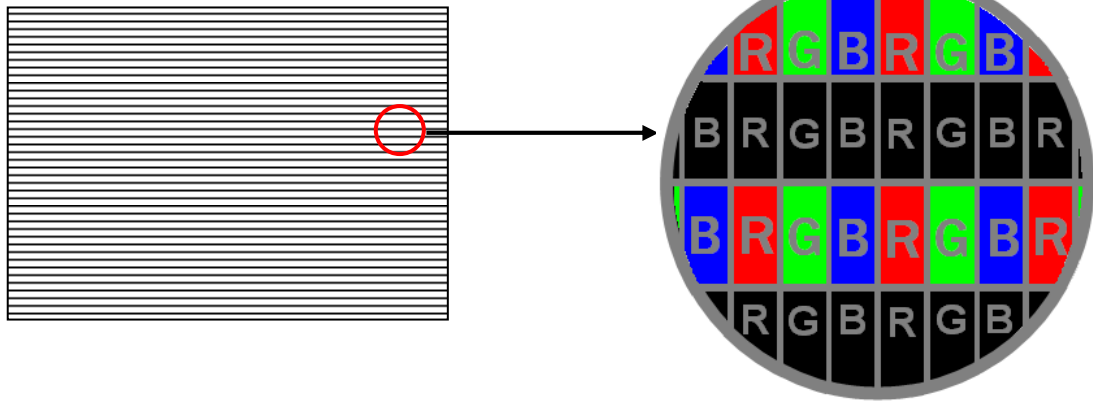

Note (4) The LVDS input characteristics are as follows:

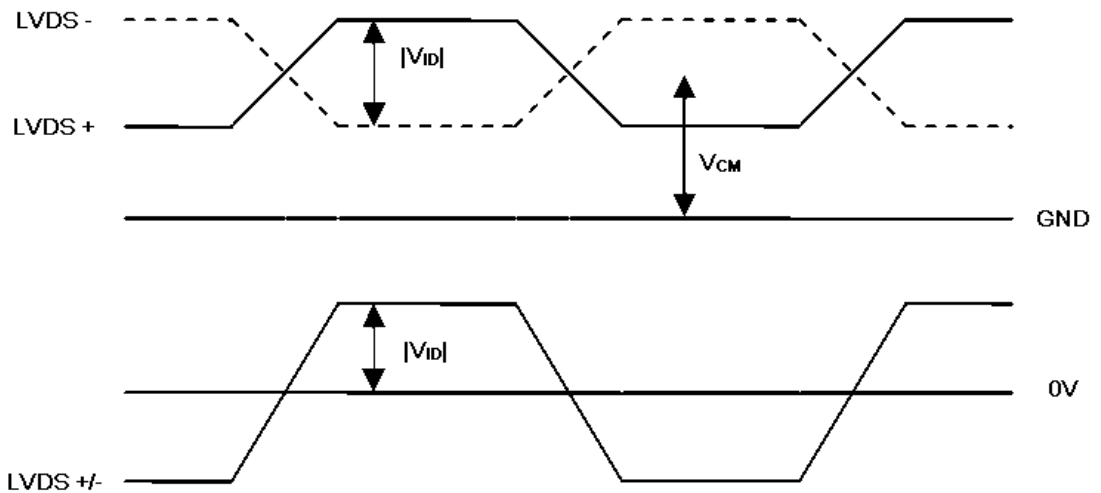

4. BLOCK DIAGRAM OF INTERFACE

4.1 TFT LCD MODULE

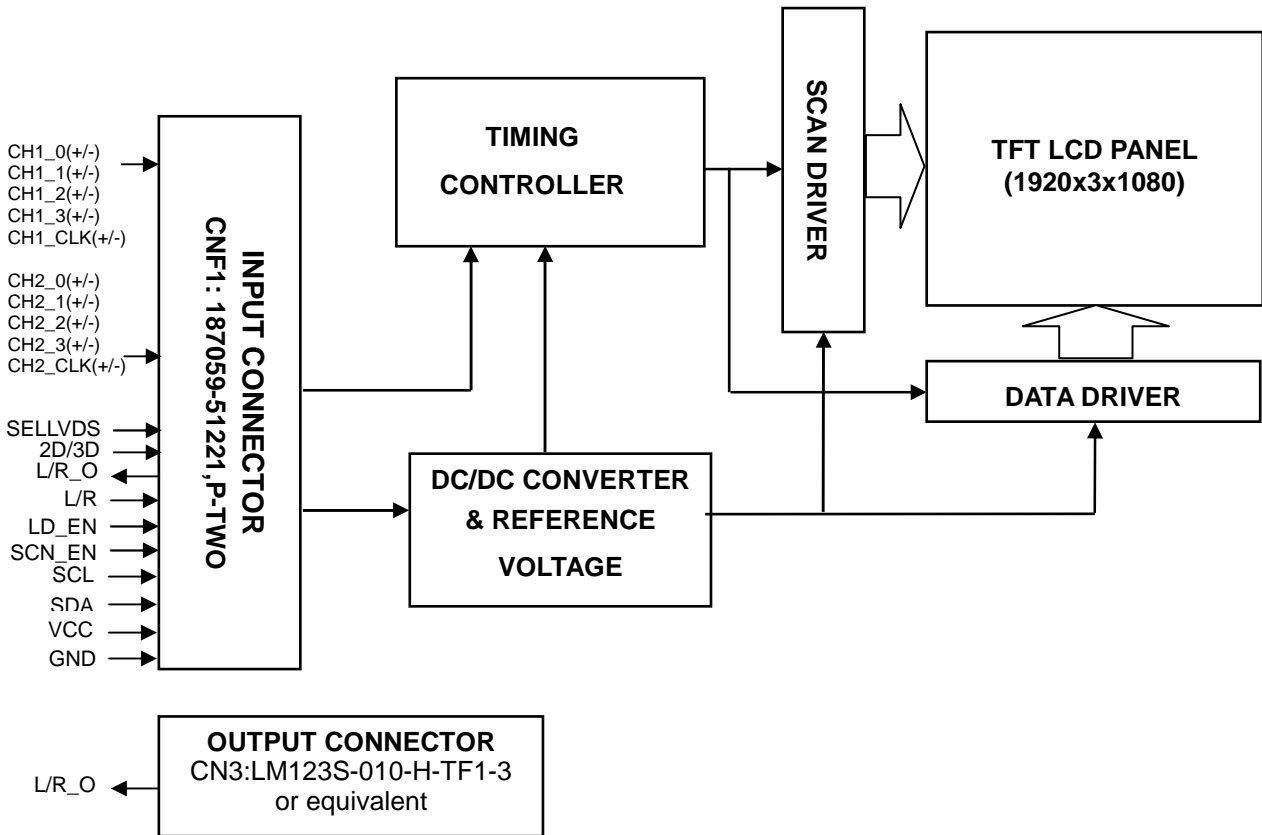

5 .INPUT TERMINAL PIN ASSIGNMENT

5.1 TFT LCD OPEN CELL

CNF1 Connector Pin Assignment: (187059-51221 (P-TWO) or equivalent)

Pin	Name	Description	Note
1	N.C.	No Connection	(1)
2	SCL	EEPROM Serial Clock (for local dimming demo function)	(11)
3	SDA	EEPROM Serial Data (for local dimming demo function)	
4	NC	No Connection	(1)
5	L/R_O	Output signal for Left Right Glasses control	(10)
6	N.C.	No Connection	(1)
7	SELLVDS	LVDS Data Format Selection	(2)(7)
8	N.C.	No Connection	(1)
9	N.C.	No Connection	
10	N.C.	No Connection	
11	GND	Ground	
12	ORX0-	Odd pixel Negative LVDS differential data input. Channel 0	(9)
13	ORX0+	Odd pixel Positive LVDS differential data input. Channel 0	
14	ORX1-	Odd pixel Negative LVDS differential data input. Channel 1	
15	ORX1+	Odd pixel Positive LVDS differential data input. Channel 1	
16	ORX2-	Odd pixel Negative LVDS differential data input. Channel 2	
17	ORX2+	Odd pixel Positive LVDS differential data input. Channel 2	
18	GND	Ground	
19	OCLK-	Odd pixel Negative LVDS differential clock input	(9)
20	OCLK+	Odd pixel Positive LVDS differential clock input	
21	GND	Ground	
22	ORX3-	Odd pixel Negative LVDS differential data input. Channel 3	(9)
23	ORX3+	Odd pixel Positive LVDS differential data input. Channel 3	
24	N.C.	No Connection	(1)
25	N.C.	No Connection	
26	2D/3D	Input signal for 2D/3D Mode Selection	(3)(6)(8)
27	L/R	Input signal for Left Right eye frame synchronous	(4)(8)
28	ERX0-	Even pixel Negative LVDS differential data input. Channel 0	(9)

29	ERX0+	Even pixel Positive LVDS differential data input. Channel 0	(9)
30	ERX1-	Even pixel Negative LVDS differential data input. Channel 1	
31	ERX1+	Even pixel Positive LVDS differential data input. Channel 1	
32	ERX2-	Even pixel Negative LVDS differential data input. Channel 2	
33	ERX2+	Even pixel Positive LVDS differential data input. Channel 2	
34	GND	Ground	
35	ECLK-	Even pixel Negative LVDS differential clock input.	(9)
36	ECLK+	Even pixel Positive LVDS differential clock input.	
37	GND	Ground	
38	ERX3-	Even pixel Negative LVDS differential data input. Channel 3	(9)
39	ERX3+	Even pixel Positive LVDS differential data input. Channel 3	
40	N.C.	No Connection	(1)
41	N.C.	No Connection	
42	LD_EN	Input signal for Local Dimming Enable	(5)(7)
43	SCN_EN	Input signal for Scanning Enable	(6)(8)
44	GND	Ground	
45	GND	Ground	
46	GND	Ground	
47	N.C.	No Connection	(1)
48	VCC	+12V power supply	
49	VCC	+12V power supply	
50	VCC	+12V power supply	
51	VCC	+12V power supply	

CN3 Connector Pin Assignment (LM123S-010-H-TF1-3 (UNE) or equivalent)

1	N.C.	No Connection	(1)
2	N.C.	No Connection	
3	N.C.	No Connection	
4	GND	Ground	
5	N.C.	No Connection	(1)
6	L/R_O	Output signal for Left Right Glasses control	(10))
7	N.C.	No Connection	(1)
8	N.C.	No Connection	
9	N.C.	No Connection	
10	N.C.	No Connection	

Note (1) Reserved for internal use. Please leave it open.

Note (2) LVDS format selection.

L= Connect to GND, H=Connect to +3.3V or open

SELLVDS	Note
L	JEIDA Format
H or Open	VESA Format

Note (3) 2D/3D mode selection.

L= Connect to GND or Open, H=Connect to +3.3V

2D/3D	Note
L or Open	2D Mode
H	3D Mode

Note (4) Input signal for Left Right eye frame synchronous

$V_{IL}=0\sim 0.8\text{ V}$, $V_{IH}=2.0\sim 3.3\text{ V}$

L/R	Note
L	Right synchronous signal
H	Left synchronous signal

Note (5) Local dimming enable selection.

L= Connect to GND H=Connect to +3.3V or Open

LD_EN	Note
L	Local Dimming Disable
H or Open	Local Dimming Enable

Note (6) Scanning enable selection.

L= Connect to GND or Open, H=Connect to +3.3V

SCN_EN	Note
L or Open	Scanning Disable
H	Scanning Enable

Note (7) SELLVDS · LD_EN signal pin connected to the LCM side has the following diagram.

R1 in the system side should be less than 1K Ohm. ($R1 < 1K \text{ Ohm}$)

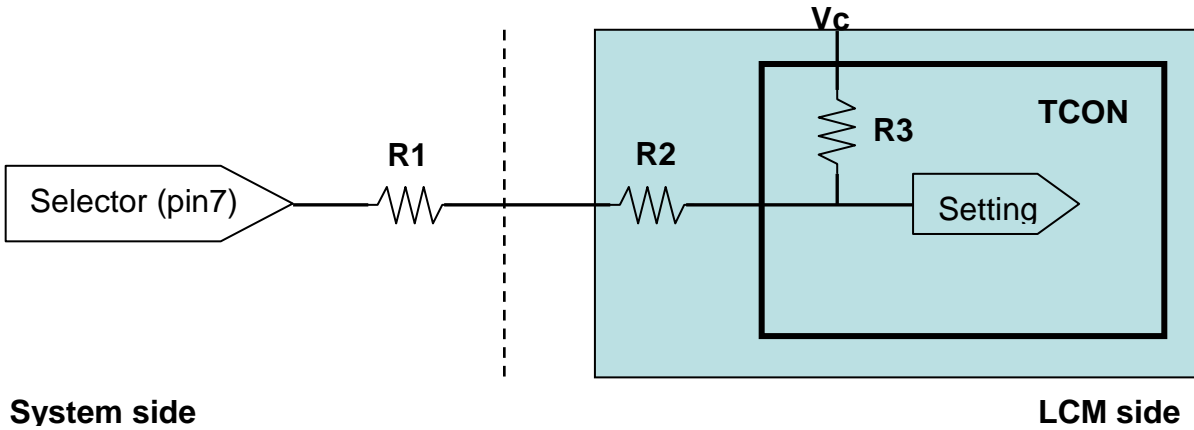

System side

LCM side

System side

$R1 < 1K$

Note (8) 2D/3D, L/R and SCN_EN signal pin connected to the LCM side has the following diagram.

R1 in the system side should be less than 1K Ohm. ($R1 < 1K \text{ Ohm}$)

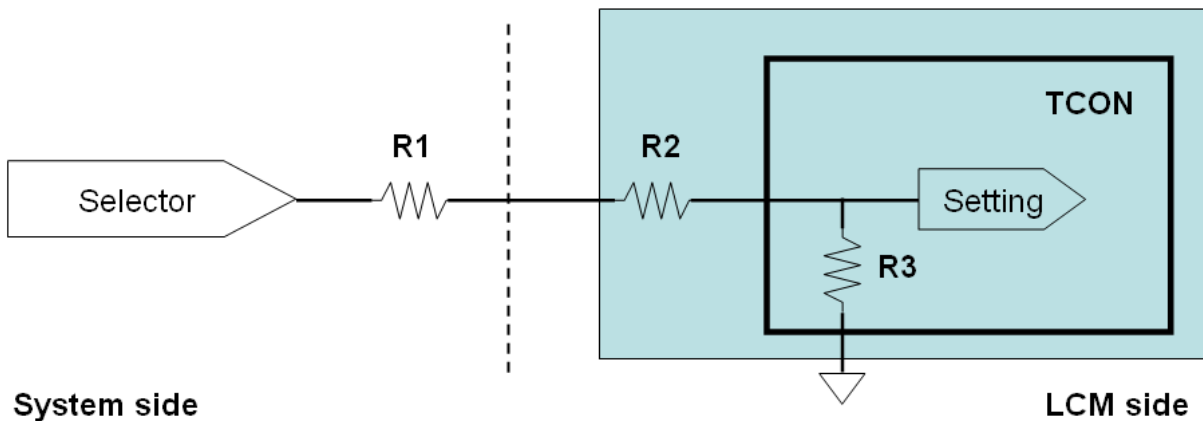

System side

LCM side

System side: $R1 < 1K$

Note (9) Two pixel data send into the module for every clock cycle. The first pixel of the frame is odd pixel and the second pixel is even pixel.

Note (10) The definition of L/R_O signal as follows

L= 0V , H= +3.3V

L/R_O	Note
L	Right glass turn on
H	Left glass turn on

Note (11) Please reference Appendix A.

Note (12) The screw hole which is distant from the connector is merged with Ground

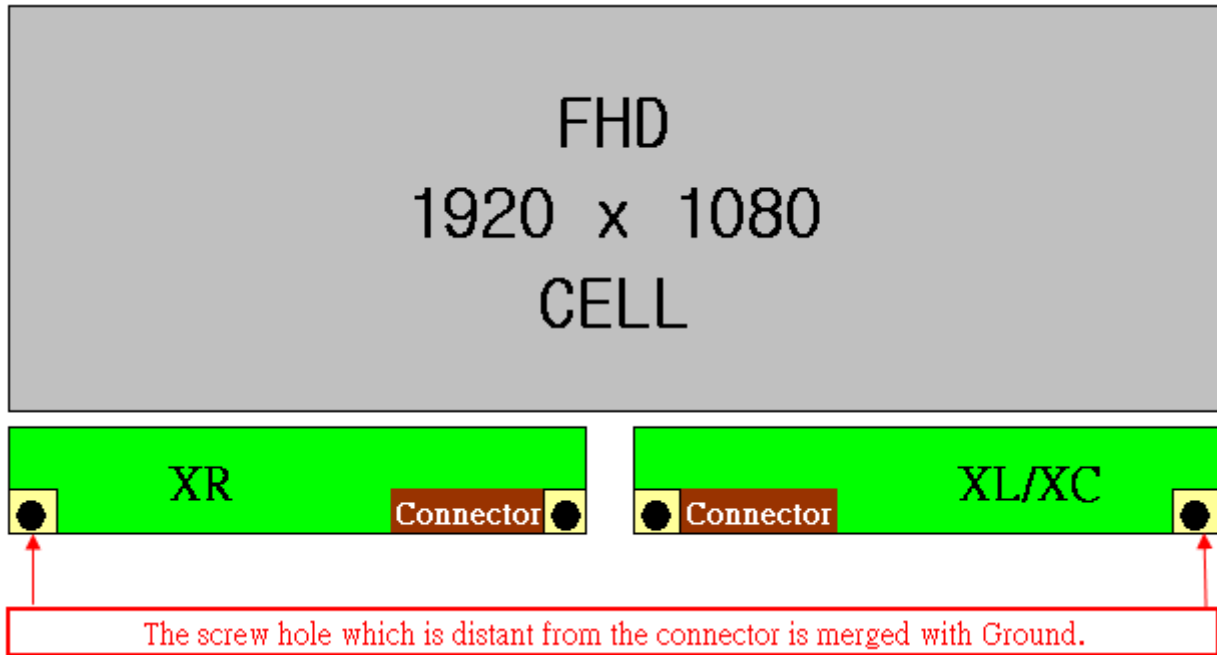

5.2 BLOCK DIAGRAM OF INTERFACE

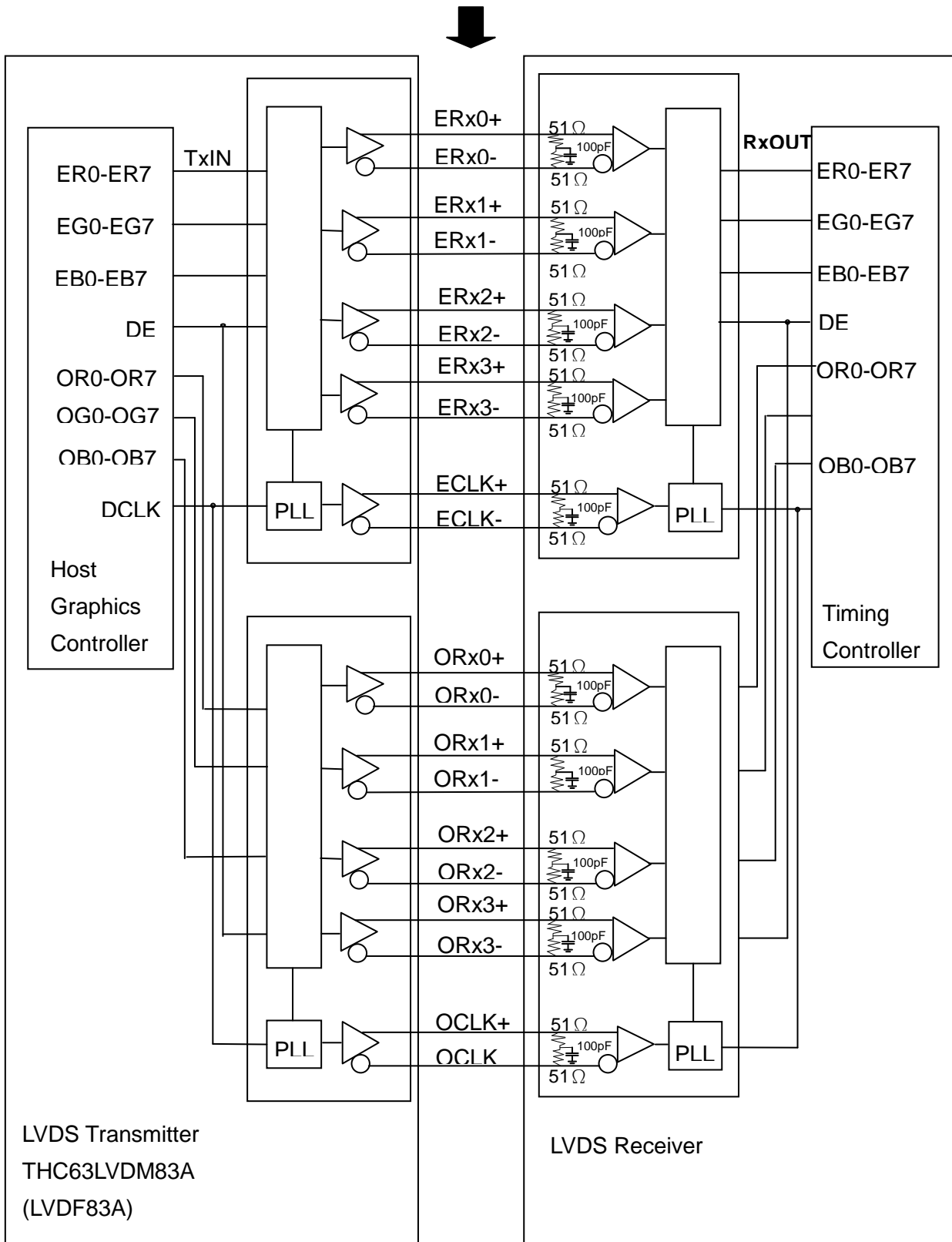

- ER0~ER7: Even pixel R data
- EG0~EG7: Even pixel G data
- EB0~EB7: Even pixel B data
- OR0~OR7: Odd pixel R data
- OG0~OG7: Odd pixel G data
- OB0~OB7: Odd pixel B data
- DE: Data enable signal
- DCLK: Data clock signal

Note (1) The system must have the transmitter to drive the module.

Note (2) LVDS cable impedance shall be 50 ohms per signal line or about 100 ohms per twist-pair line when it is used differentially.

5.2 LVDS INTERFACE

- JEIDA Format : SELLVDS = L
- VESA Format : SELLVDS = H or Open
- VESA LVDS format

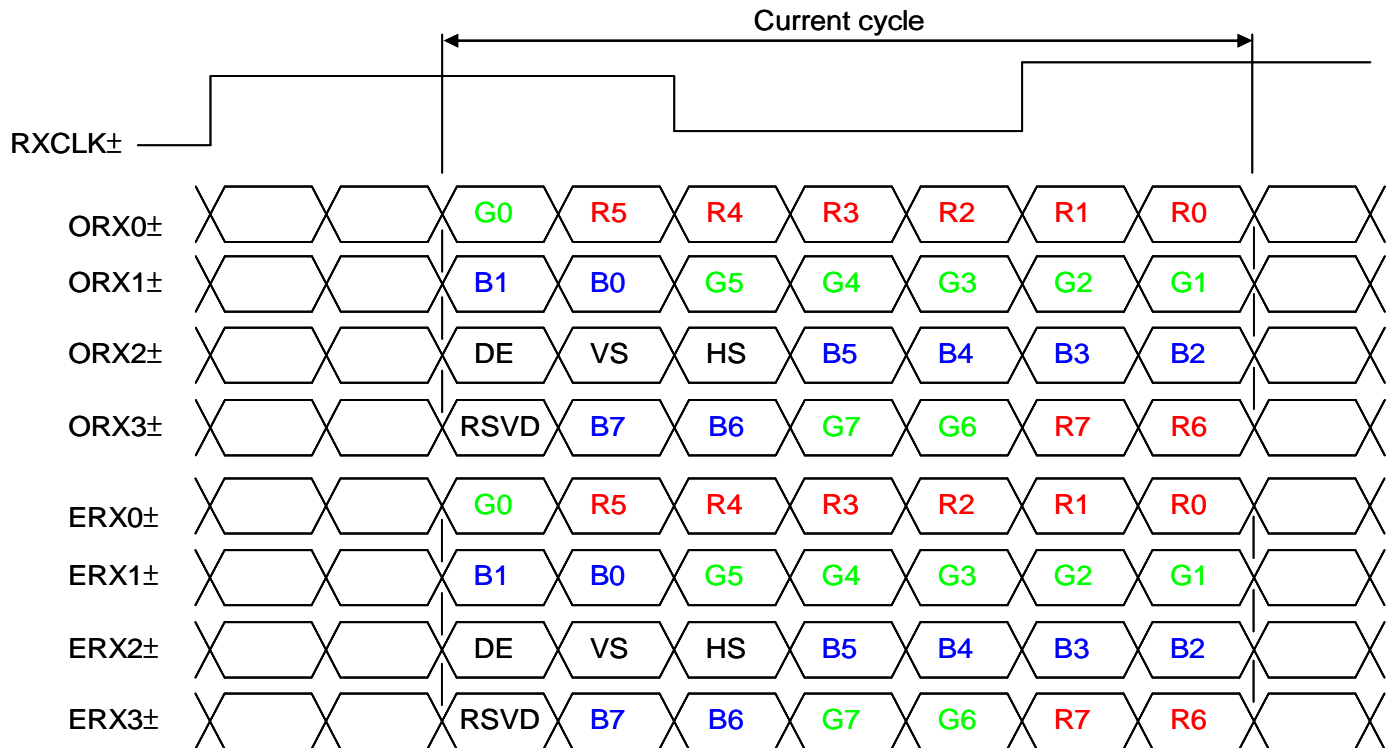

JEDIA LVDS format

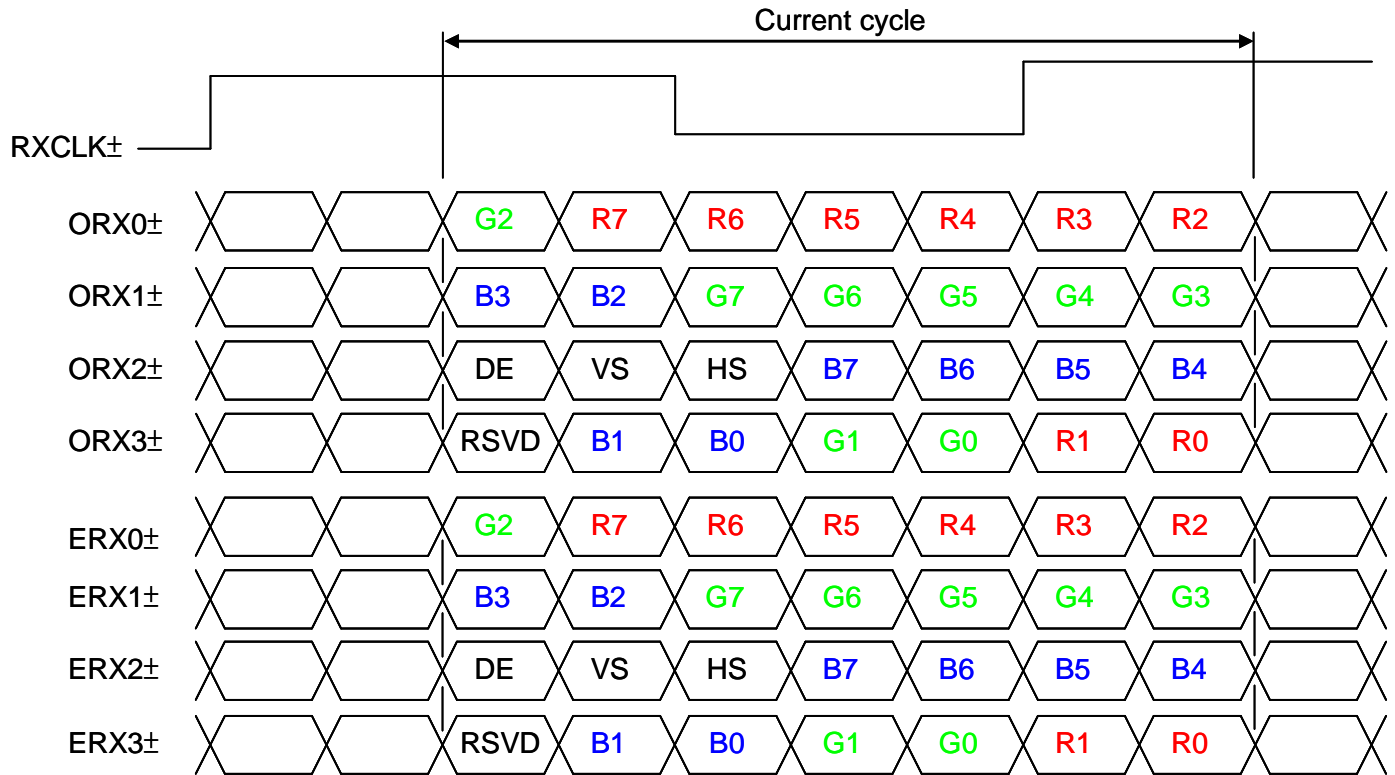

5.3 COLOR DATA INPUT ASSIGNMENT

The brightness of each primary color (red, green and blue) is based on the 8-bit gray scale data input for the color. The higher the binary input, the brighter the color. The table below provides the assignment of the color versus data input.

Color		Data Signal																							
		Red								Green								Blue							
		R7	R6	R5	R4	R3	R2	R1	R0	G7	G6	G5	G4	G3	G2	G1	G0	B7	B6	B5	B4	B3	B2	B1	B0
Basic Colors	Black	0	0	0	0	0	0	0	0	0	0	0	0	0	0	0	0	0	0	0	0	0	0	0	0
	Red	1	1	1	1	1	1	1	1	0	0	0	0	0	0	0	0	0	0	0	0	0	0	0	0
	Green	0	0	0	0	0	0	0	0	1	1	1	1	1	1	1	1	0	0	0	0	0	0	0	0
	Blue	0	0	0	0	0	0	0	0	0	0	0	0	0	0	0	0	1	1	1	1	1	1	1	1
	Cyan	0	0	0	0	0	0	0	0	1	1	1	1	1	1	1	1	1	1	1	1	1	1	1	1
	Magenta	1	1	1	1	1	1	1	1	0	0	0	0	0	0	0	0	1	1	1	1	1	1	1	1
	Yellow	1	1	1	1	1	1	1	1	1	1	1	1	1	1	1	1	0	0	0	0	0	0	0	0
White	1	1	1	1	1	1	1	1	1	1	1	1	1	1	1	1	1	1	1	1	1	1	1	1	
Gray Scale Of Red	Red (0) / Dark	0	0	0	0	0	0	0	0	0	0	0	0	0	0	0	0	0	0	0	0	0	0	0	0
	Red (1)	0	0	0	0	0	0	0	1	0	0	0	0	0	0	0	0	0	0	0	0	0	0	0	0
	Red (2)	0	0	0	0	0	0	1	0	0	0	0	0	0	0	0	0	0	0	0	0	0	0	0	0
	⋮	⋮	⋮	⋮	⋮	⋮	⋮	⋮	⋮	⋮	⋮	⋮	⋮	⋮	⋮	⋮	⋮	⋮	⋮	⋮	⋮	⋮	⋮	⋮	⋮
	Red (253)	1	1	1	1	1	1	0	1	0	0	0	0	0	0	0	0	0	0	0	0	0	0	0	0
	Red (254)	1	1	1	1	1	1	1	0	0	0	0	0	0	0	0	0	0	0	0	0	0	0	0	0
	Red (255)	1	1	1	1	1	1	1	1	0	0	0	0	0	0	0	0	0	0	0	0	0	0	0	0
Gray Scale Of Green	Green (0) / Dark	0	0	0	0	0	0	0	0	0	0	0	0	0	0	0	0	0	0	0	0	0	0	0	0
	Green (1)	0	0	0	0	0	0	0	0	0	0	0	0	0	0	1	0	0	0	0	0	0	0	0	
	Green (2)	0	0	0	0	0	0	0	0	0	0	0	0	0	0	1	0	0	0	0	0	0	0	0	
	⋮	⋮	⋮	⋮	⋮	⋮	⋮	⋮	⋮	⋮	⋮	⋮	⋮	⋮	⋮	⋮	⋮	⋮	⋮	⋮	⋮	⋮	⋮	⋮	
	Green (253)	0	0	0	0	0	0	0	0	1	1	1	1	1	1	0	1	0	0	0	0	0	0	0	
	Green (254)	0	0	0	0	0	0	0	0	1	1	1	1	1	1	1	0	0	0	0	0	0	0	0	
	Green (255)	0	0	0	0	0	0	0	0	1	1	1	1	1	1	1	0	0	0	0	0	0	0	0	
Gray Scale Of Blue	Blue (0) / Dark	0	0	0	0	0	0	0	0	0	0	0	0	0	0	0	0	0	0	0	0	0	0	0	0
	Blue (1)	0	0	0	0	0	0	0	0	0	0	0	0	0	0	0	0	0	0	0	0	0	0	0	1
	Blue (2)	0	0	0	0	0	0	0	0	0	0	0	0	0	0	0	0	0	0	0	0	0	0	1	0
	⋮	⋮	⋮	⋮	⋮	⋮	⋮	⋮	⋮	⋮	⋮	⋮	⋮	⋮	⋮	⋮	⋮	⋮	⋮	⋮	⋮	⋮	⋮	⋮	⋮
	Blue (253)	0	0	0	0	0	0	0	0	0	0	0	0	0	0	0	0	0	1	1	1	1	1	1	0
	Blue (254)	0	0	0	0	0	0	0	0	0	0	0	0	0	0	0	0	0	1	1	1	1	1	1	1
	Blue (255)	0	0	0	0	0	0	0	0	0	0	0	0	0	0	0	0	1	1	1	1	1	1	1	1

Note (1) 0: Low Level Voltage, 1: High Level Voltage

5.4 FLICKER (Vcom) ADJUSTMENT

(1) Adjustment Pattern:

Flick pattern was shown as below. If customer need below pattern, please directly contact with Account FAE.

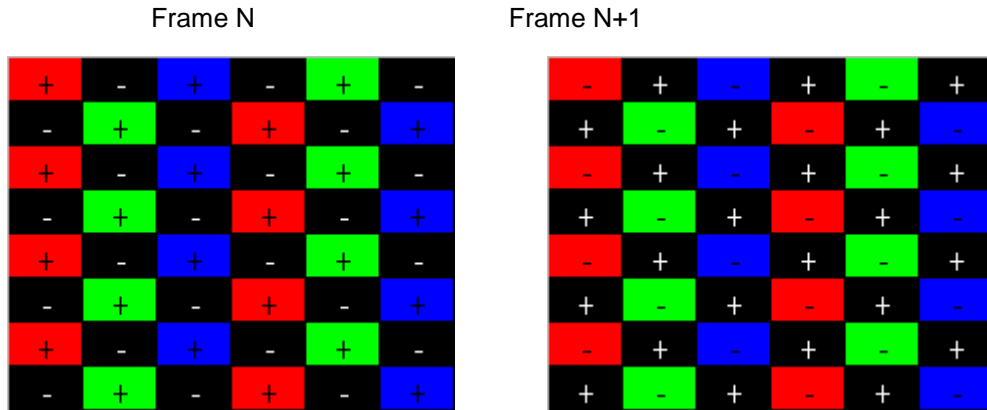

(2) Adjustment method: (Auto-Gamma)

Programmable memory IC is used for Auto-Gamma adjustment in this model. CMI provide Auto Gamma tools to adjust Auto-Gamma. The detail connection and setting instruction, please directly contact with Account FAE or refer CMI Auto-Gamma adjustment OI. Below items is suggested to be ready before Auto-Gamma adjustment in customer LCM line.

- a. USB Sensor Board.
- b. Programmable software.

6. INTERFACE TIMING

6.1 INPUT SIGNAL TIMING SPECIFICATIONS

(Ta = 25 ± 2 °C)

The input signal timing specifications are shown as the following table and timing diagram.

Signal	Item	Symbol	Min.	Typ.	Max.	Unit	Note
LVDS Receiver Clock	Frequency	$F_{clk_{in}}$ (=1/TC)	60	74.25	77	MHz	
	Input cycle to cycle jitter	T_{rcj}	-	-	200	ps	(2)
	Spread spectrum modulation range	$F_{clk_{in_mod}}$	$F_{clk_{in}}-2\%$	-	$F_{clk_{in}}+2\%$	MHz	(3)
	Spread spectrum modulation frequency	F_{SSM}	-	-	200	KHz	
LVDS Receiver Data	Receiver Skew margin	TRSKM	-400	-	400	ps	(4)

6.1.1 Timing spec for Frame Rate = 50Hz

Signal	Item	Symbol	Min.	Typ.	Max.	Unit	Note	
Frame rate	2D mode	F_{r5}	47	50	53	Hz		
	3D mode	F_{r5}	50	50	50	Hz	(6)	
Vertical Active Display Term	2D Mode	Total	T_v	1115	1125	1380	Th	$T_v=T_{vd}+T_{vb}$
		Display	T_{vd}	1080	1080	1080	Th	—
		Blank	T_{vb}	35	45	300	Th	—
	3D Mdoe	Total	T_v	1350			Th	(5),(7)
		Display	T_{vd}	1080			Th	
		Blank	T_{vb}	270			Th	
Horizontal Active Display Term	2D Mode	Total	T_h	1050	1100	1150	Tc	$T_h=T_{hd}+T_{hb}$
		Display	T_{hd}	960	960	960	Tc	—
		Blank	T_{hb}	90	140	190	Tc	—
	3D Mdoe	Total	T_h	1050	1100	1150	Tc	$T_h=T_{hd}+T_{hb}$

	Display	Thd	960	960	960	Tc	—
	Blank	Thb	90	140	190	Tc	—

6.1.2 Timing spec for Frame Rate = 60Hz

Signal	Item	Symbol	Min.	Typ.	Max.	Unit	Note	
Frame rate	2D mode	F_{r6}	57	60	62.5	Hz		
	3D mode	F_{r6}	60	60	60	Hz	(6)	
Vertical Active Display Term	2D Mode	Total	T_v	1115	1125	1380	Th	$T_v = T_{vd} + T_{vb}$
		Display	T_{vd}	1080	1080	1080	Th	—
		Blank	T_{vb}	35	45	300	Th	—
	3D Mdoe	Total	T_v	1125			Th	(5), (7)
		Display	T_{vd}	1080			Th	
		Blank	T_{vb}	45			Th	
Horizontal Active Display Term	2D Mode	Total	T_h	1050	1100	1150	Tc	$T_h = T_{hd} + T_{hb}$
		Display	T_{hd}	960	960	960	Tc	—
		Blank	T_{hb}	90	140	190	Tc	—
	3D Mdoe	Total	T_h	1050	1100	1150	Tc	$T_h = T_{hd} + T_{hb}$
		Display	T_{hd}	960	960	960	Tc	—
		Blank	T_{hb}	90	140	190	Tc	—

Note (1) Please make sure the range of pixel clock has follow the below equation:

$$F_{clk}(max) \geq F_{r6} \times T_v \times T_h$$

$$F_{r5} \times T_v \times T_h \geq F_{clk}(min)$$

INPUT SIGNAL TIMING DIAGRAM

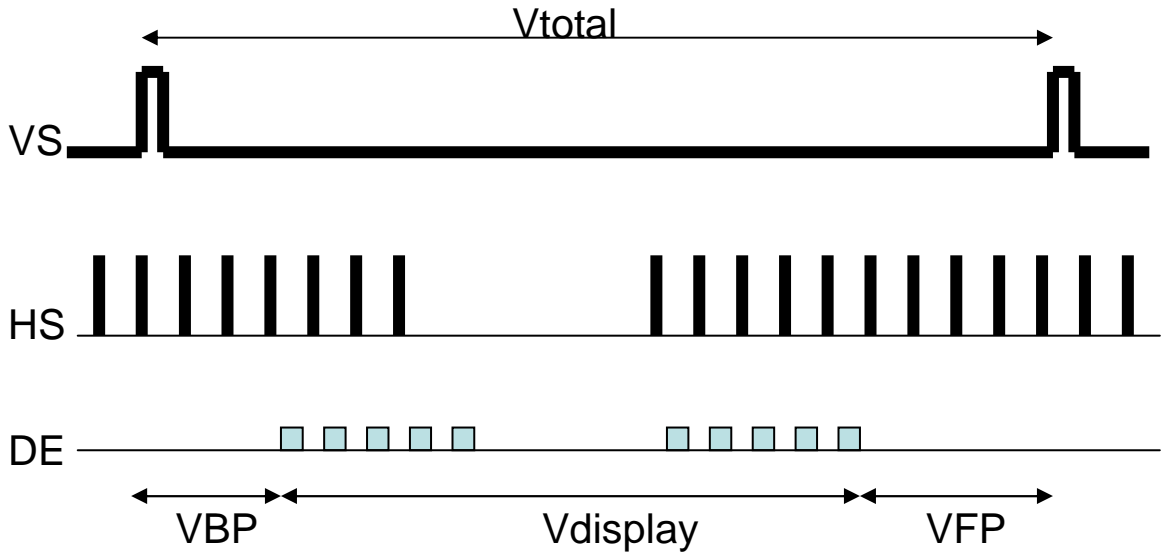

- VBP max : 150 line

Suggest $VBP = VFP = \frac{1}{2} * (Vtotal - Vdisplay)$

DE timing

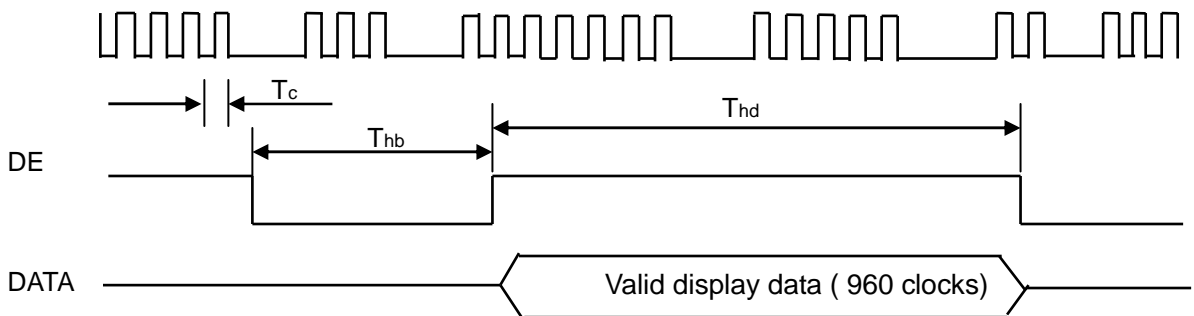
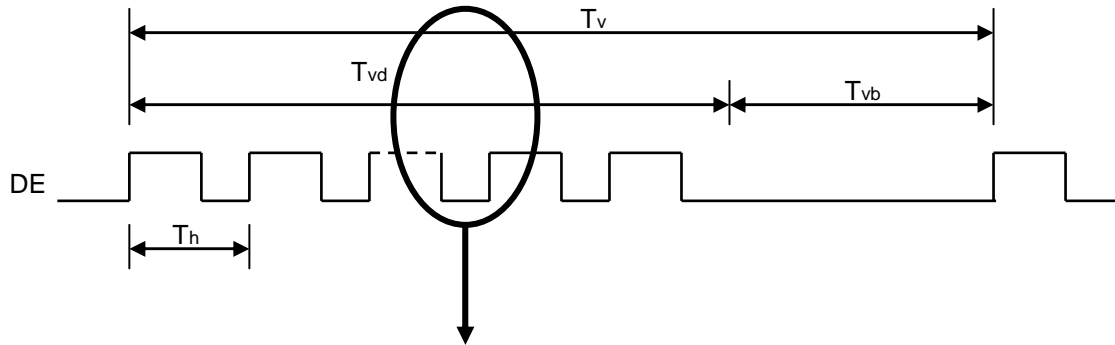

Note (2) The input clock cycle-to-cycle jitter is defined as below figures. $Trcl = |T_1 - T_1|$

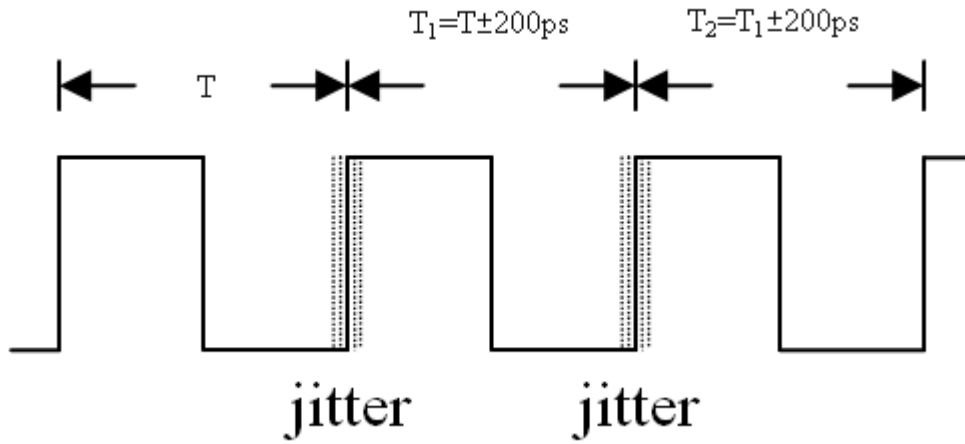

Note (3) The SSCG (Spread spectrum clock generator) is defined as below figures.

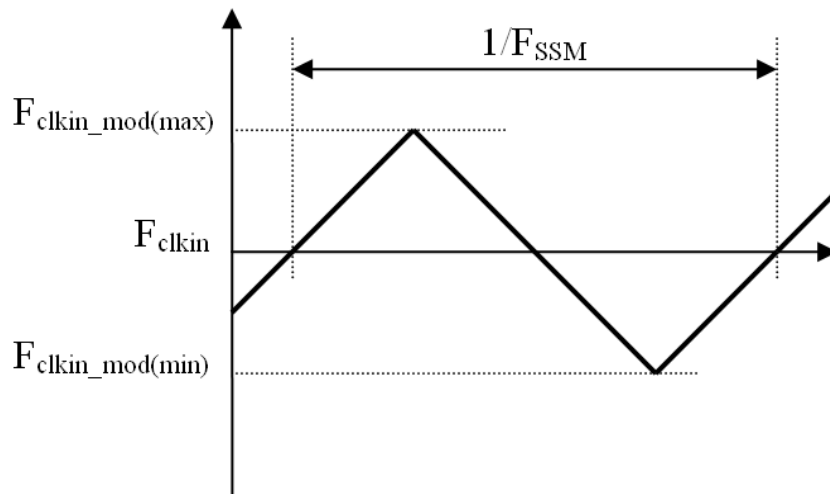

Note (4) LVDS receiver skew margin is defined and shown as below

LVDS RECEIVER INTERFACE TIMING DIAGRAM

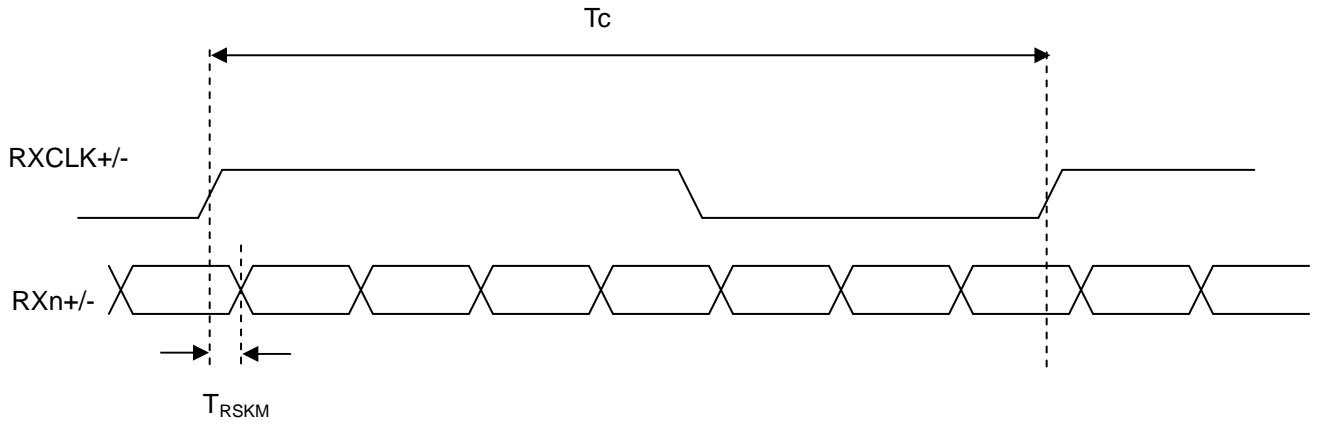

Note (5) Please fix the Vertical timing (Vertical Total =1350 / Display =1080 / Blank = 270) in 50Hz 3D mode and Vertical timing (Vertical Total =1125 / Display =1080 / Blank = 45) in 60Hz 3D mode

Note (6) In 3D mode, the set up Fr5 and Fr6 in Typ. ± 3 Hz .In order to ensure that the electric function performance to avoid no display symptom.(Except picture quality symptom.)

Note (7) In 3D mode, the set up Tv and Tvb in Typ. ± 30 .In order to ensure that the electric function performance to avoid no display symptom.(Except picture quality symptom.)

6.2 POWER ON/OFF SEQUENCE (Ta = 25 ± 2 °C)

6.2.1 POWER ON/OFF SEQUENCE

To prevent a latch-up or DC operation of LCD module, the power on/off sequence should be as the diagram below.

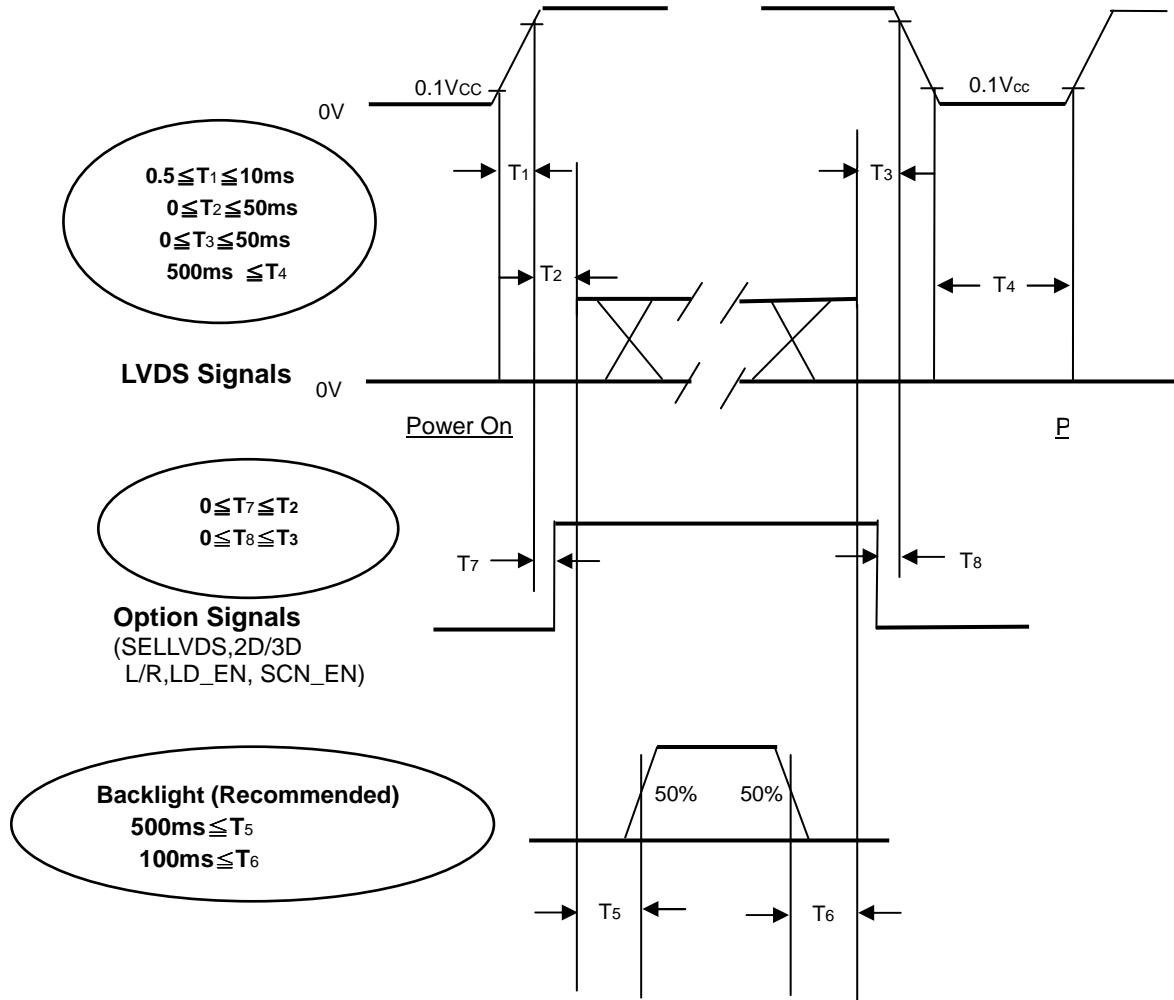

Power ON/OFF Sequence

6.2.2 2D/3D MODE CHANGE 2D to 3D SIGNAL SEQUENCE WITHOUT VCC TURN OFF AND TURN ON

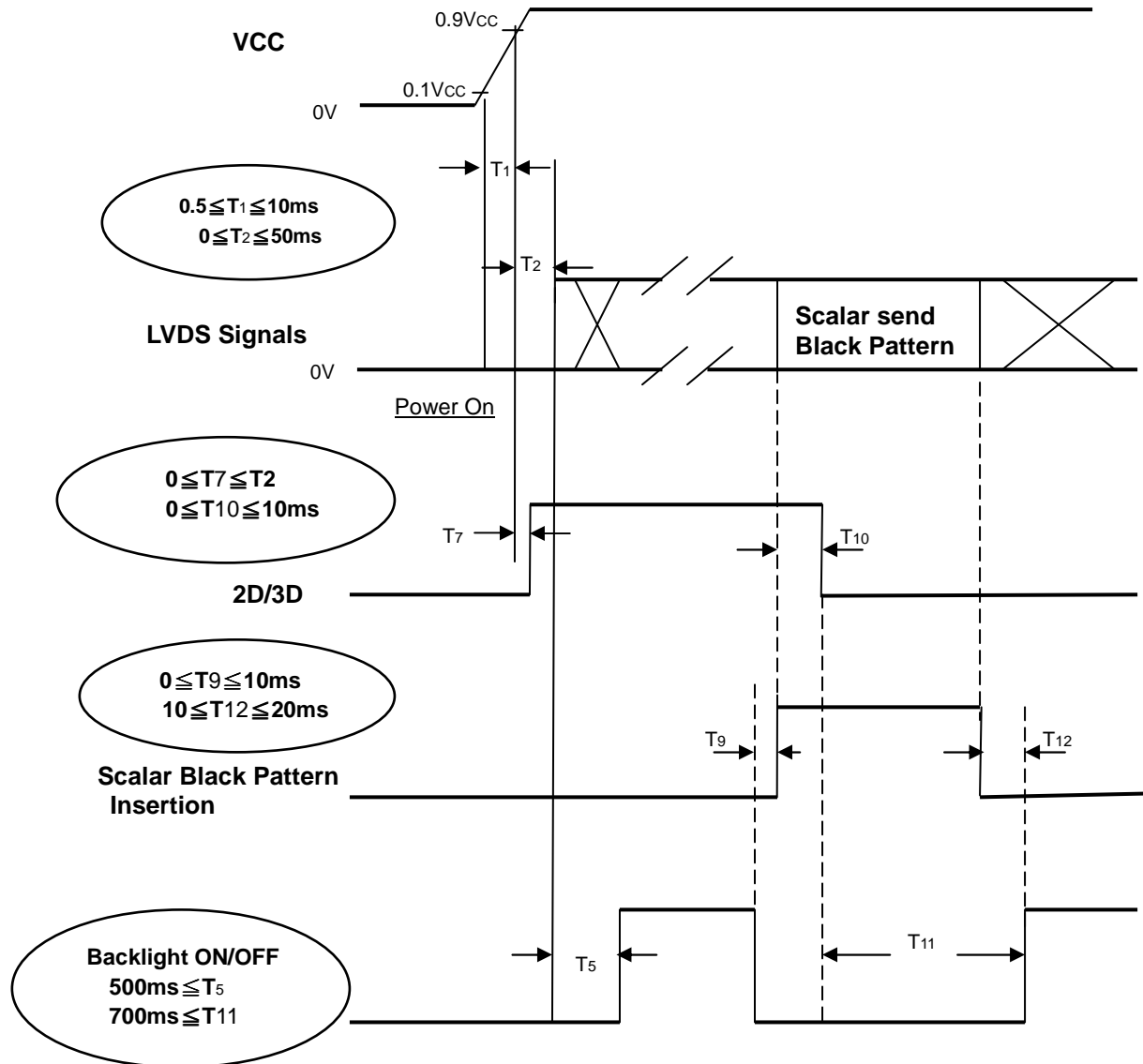

Note (1) The supply voltage of the external system for the module input should follow the definition of V_{CC}.

Note (2) Apply the LED voltage within the LCD operation range. When the backlight turns on before the LCD operation or the LCD turns off before the backlight turns off, the display may momentarily become abnormal screen.

Note (3) In case of V_{CC} is in off level, please keep the level of input signals on the low or high impedance. If $T_2 < 0$, that maybe cause electrical overstress failure.

Note (4) T₄ should be measured after the module has been fully discharged between power off and on period.

Note (5) Interface signal shall not be kept at high impedance when the power is on.

Note (6) When 2D/3D mode is changed, TCON will insert black pattern internally. During black insertion, TCON would load required optical table and TCON parameter setting. The black insertion time should be longer than 650ms because TCON must recognize 2D or 3D format and set the correct parameter.

Note (7) 2D/3D switching time should be larger than 500ms.

7. OPTICAL CHARACTERISTICS

7.1 TEST CONDITIONS

Item	Symbol	Value	Unit
Ambient Temperature	Ta	25±2	°C
Ambient Humidity	Ha	50±10	%RH
Supply Voltage	V _{CC}	12V	V
Input Signal	According to typical value in "3. ELECTRICAL CHARACTERISTICS"		
LED Current	I _L	110	mA

Local Dimming Function should be Disable before testing to get the steady optical characteristics (According to 5.1 CNF1 Connector Pin Assignment, Pin no. "42")

The LCD module should be stabilized at given temperature for 1 hour to avoid abrupt temperature change during measuring in a windless room.

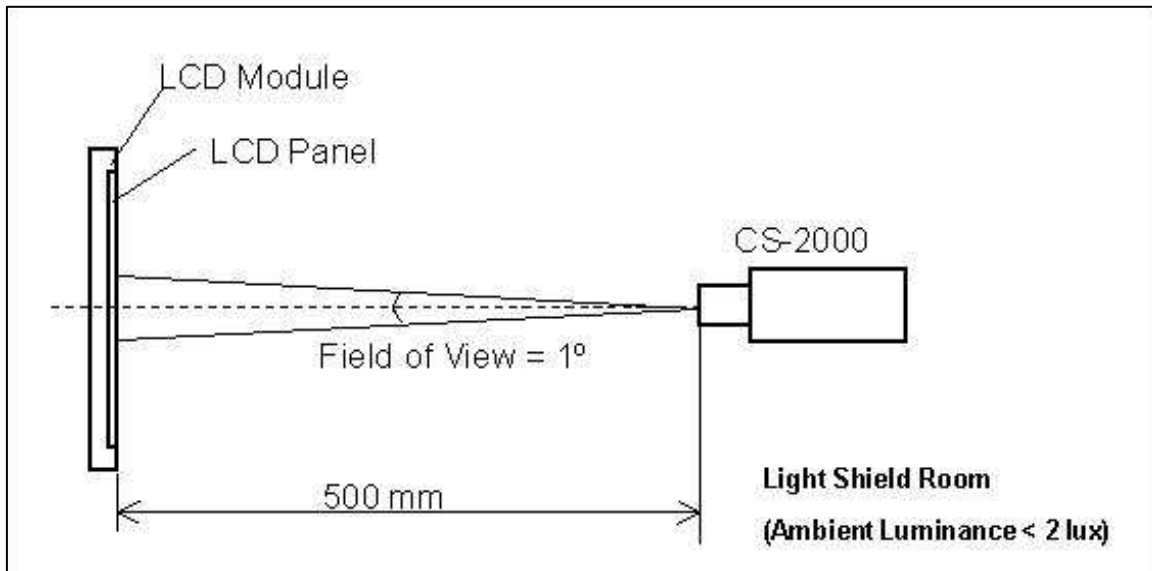

7.2 OPTICAL SPECIFICATIONS

The relative measurement methods of optical characteristics are shown as below. The following items should be measured under the test conditions described in 7.1 and stable environment shown in 7.1.

Item		Symbol	Condition	Min.	Typ.	Max.	Unit	Note
Color Chromaticity	Red	Rcx	$\theta_x=0^\circ, \theta_y=0^\circ$ Viewing Angle at Normal Direction Standard light source "C"	-	0.658	-	-	(0)
		Rcy			0.322		-	
	Green	Gcx			0.266		-	
		Gcy			0.583		-	
	Blue	Bcx			0.134		-	
		Bcy			0.103		-	
	White	Wcx			0.300		-	
		Wcy			0.349		-	
Center Transmittance		T%	$\theta_x=0^\circ, \theta_y=0^\circ$	-	6.4	-	%	(1),(6)
Contrast Ratio		CR	with CMI module	3500	5000	-	-	(1),(3)
Response Time		Gray to gray	$\theta_x=0^\circ, \theta_y=0^\circ$ with CMI Module	-	6	12	ms	(1),(4)
White Variation		δW	$\theta_x=0^\circ, \theta_y=0^\circ$ with CMI module	-	-	1.3	-	(1),(5)
Viewing Angle	Horizontal	θ_{x+}	CR \geq 20 With CMI module	-	88	-	Deg.	(1),(2)
		θ_{x-}		-	88	-		
	Vertical	θ_{y+}		-	88	-		
		θ_{y-}		-	88	-		

Note (0) Light source is the standard light source "C" which is defined by CIE and driving voltage are based on suitable gamma voltages. The calculating method is as following:

1. Measure Module's and BLU's spectrum at center point. White and R,G,B are with signal input. BLU (for V546HK3-LS5) is supplied by CMI.
2. Calculate cell's spectrum.
3. Calculate cell's chromaticity by using the spectrum of standard light source "C".

Note (1) Light source is the BLU which supplied by CMI and driving voltage are based on suitable gamma voltages.

Note (2) Definition of Viewing Angle (θ_x, θ_y):

Viewing angles are measured by Autronic Conoscope Cono-80

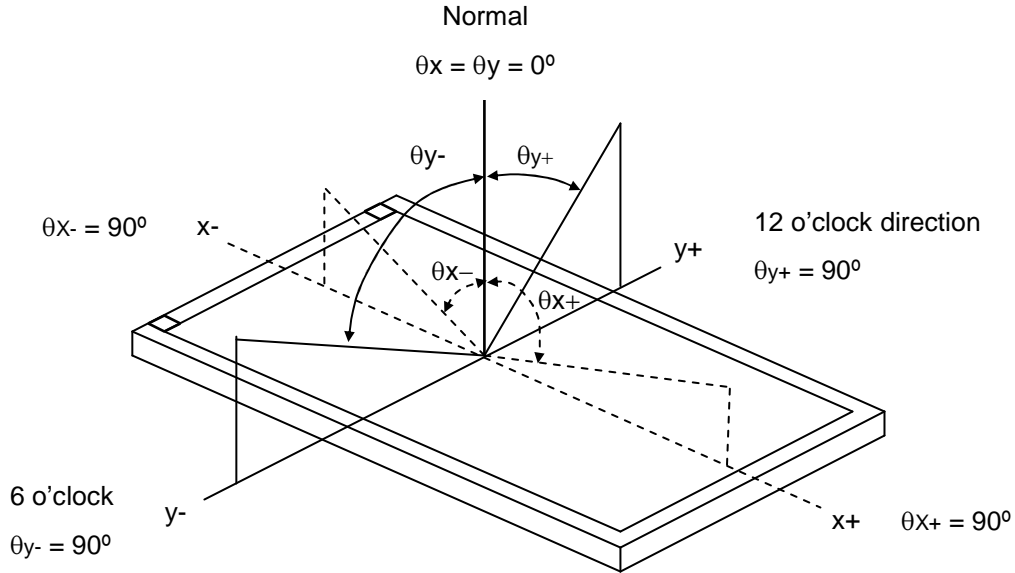

Note (3) Definition of Contrast Ratio (CR):

The contrast ratio can be calculated by the following expression.

$$\text{Contrast Ratio (CR)} = \frac{\text{Surface Luminance of L255}}{\text{Surface Luminance of L0}}$$

L255: Luminance of gray level 255

L 0: Luminance of gray level 0

CR = CR (X), where CR (X) is corresponding to the Contrast Ratio of the point X at the figure in Note (5).

Note (4) Definition of Gray-to-Gray Switching Time:

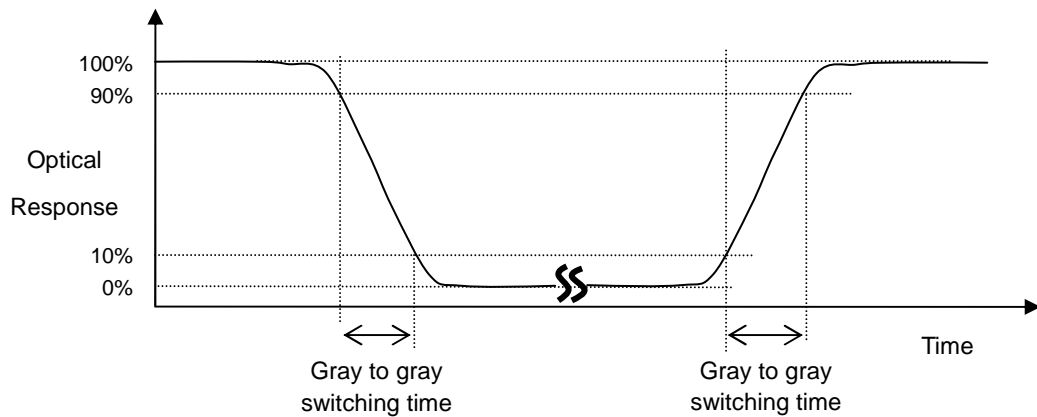

The driving signal means the signal of gray level 0, 124, 252, 380, 508, 636, 764, 892 and 1023.

Gray to gray average time means the average switching time of gray level 0, 124, 252, 380, 508, 636, 764, 892 and 1023 to each other.

Note (5) Definition of White Variation (δW):

Measure the luminance of gray level 255 at 5 points

$$\delta W = \text{Maximum [L (1), L (2), L (3), L (4), L (5)]} / \text{Minimum [L (1), L (2), L (3), L (4), L (5)]}$$

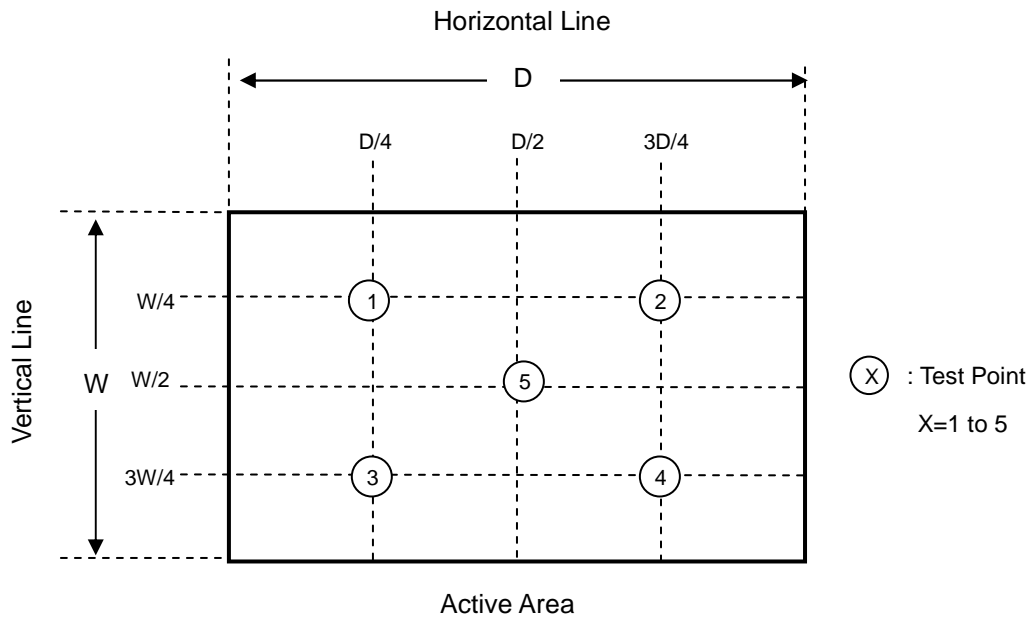

Note (6) Definition of Transmittance (T%) :

Measure the luminance of gray level 255 at center point of LCD module.

$$\text{Transmittance (T\%)} = \frac{\text{Luminance of LCD module}}{\text{Luminance of backligh unit}} \times 100\%$$

Note (7) This is a reference for designing the shutter glasses of 3D application.

Definition of the transmission direction of the up polarizer(Φ_{up-P}) on LCD Module:

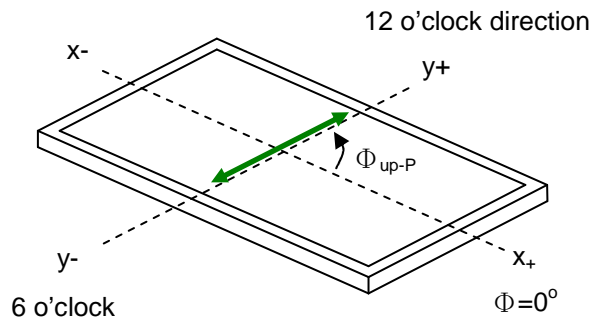

Up Polarizer

The transmission axis of the front polarizer of the shutter glasses should be parallel to this panel transmission direction to get a maximum 3D mode luminance.

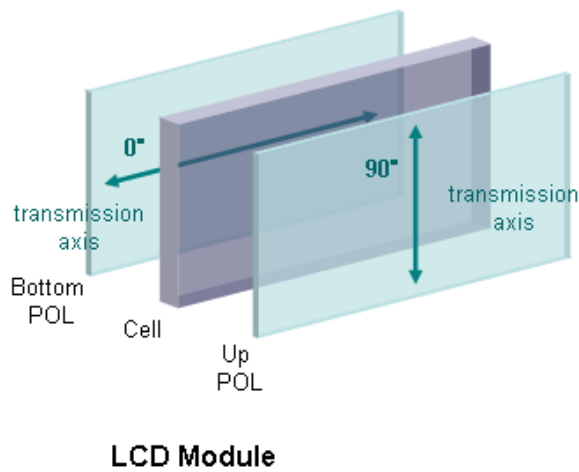

LCD Module

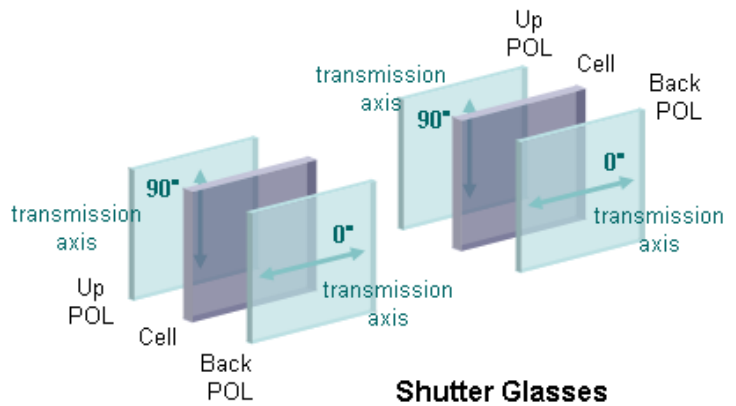

Shutter Glasses

8. PRECAUTIONS

8.1 ASSEMBLY AND HANDLING PRECAUTIONS

- [1] Do not apply rough force such as bending or twisting to the module during assembly.
- [2] It is recommended to assemble or to install a module into the user's system in clean working areas. The dust and oil may cause electrical short or worsen the polarizer.
- [3] Do not apply pressure or impulse to the module to prevent the damage of LCD panel and Backlight.
- [4] Always follow the correct power-on sequence when the LCD module is turned on. This can prevent the damage and latch-up of the CMOS LSI chips.
- [5] Do not plug in or pull out the I/F connector while the module is in operation.
- [6] Do not disassemble the module.
- [7] Use a soft dry cloth without chemicals for cleaning, because the surface of polarizer is very soft and easily scratched.
- [8] Moisture can easily penetrate into LCD module and may cause the damage during operation.
- [9] When storing modules as spares for a long time, the following precaution is necessary.
 - [9.1] Do not leave the module in high temperature, and high humidity for a long time. It is highly recommended to store the module with temperature from 0 to 35°C at normal humidity without condensation.
 - [9.2] The module shall be stored in dark place. Do not store the TFT-LCD module in direct sunlight or fluorescent light.
- [10] When ambient temperature is lower than 10°C, the display quality might be reduced. For example, the response time will become slow, and the starting voltage of CCFL will be higher than that of room temperature.

8.2 SAFETY PRECAUTIONS

- [1] The startup voltage of a Backlight is approximately 1000 Volts. It may cause an electrical shock while assembling with the inverter. Do not disassemble the module or insert anything into the Backlight unit.
- [2] If the liquid crystal material leaks from the panel, it should be kept away from the eyes or mouth. In case of contact with hands, skin or clothes, it has to be washed away thoroughly with soap.
- [3] After the module's end of life, it is not harmful in case of normal operation and storage.

9. DEFINITION OF LABELS

9.1 OPEN CELL LABEL

The barcode nameplate is pasted on each open cell as illustration for CMI internal control

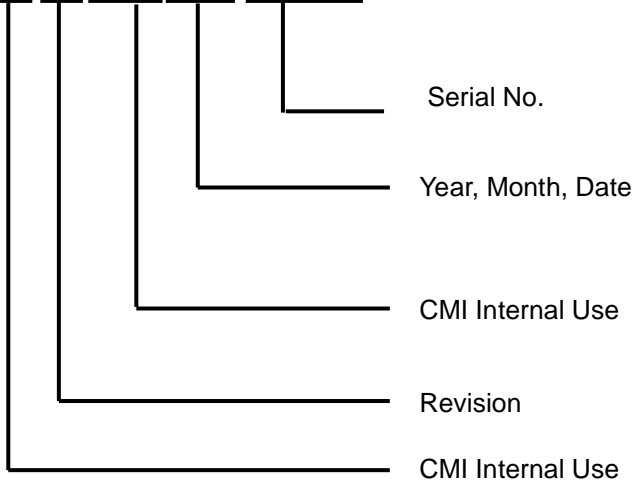

Figure.8-1 Serial No. Label on SPWB

Model Name: V546HK3-PS5

Revision: Rev. XX, for example: A0, A1... B1, B2... or C1, C2...etc.

Serial ID: XXXXXXXYMDLNNNN



Serial ID includes the information as below:

Manufactured Date:

Year: 2010=0, 2011=1,2012=2...etc.

Month: 1~9, A~C, for Jan. ~ Dec.

Day: 1~9, A~Y, for 1st to 31st, exclude I ,O, and U.

Revision Code: Cover all the change

Serial No.: Manufacturing sequence of product

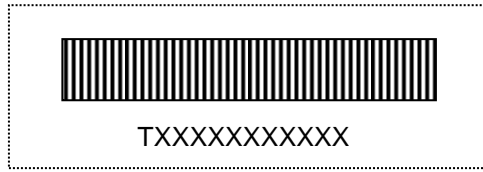
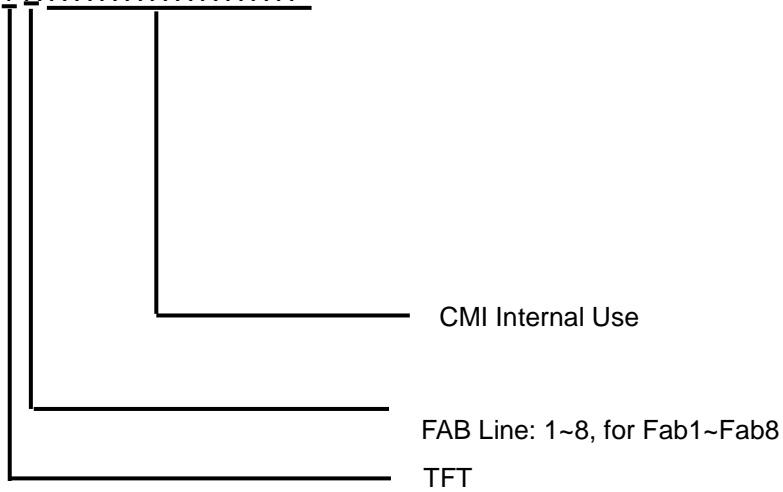

Figure.9-2 Panel ID Label on Cell

Panel ID Label includes the information as below:

Panel ID: T X X X X X X X X X X



9.2 CARTON LABEL

The barcode nameplate is pasted on each box as illustration, and its definitions are as following explanation.

PO.NO. _____
Part ID. _____ Quantities _____
Model Name _____
Carton ID. _____

(a) Model Name: V546HK3- PS5

(b) Carton ID: X X X X X X Y M D X X X X

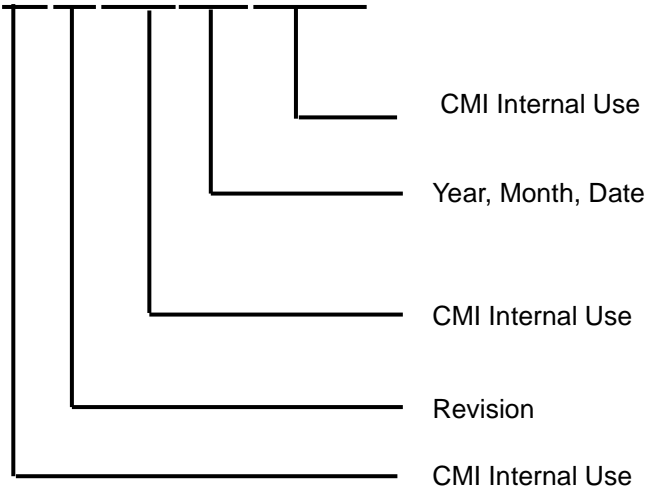

Serial ID includes the information as below:

Manufactured Date:

Year: 2010=0, 2011=1, 2012=2...etc.

Month: 1~9, A~C, for Jan. ~ Dec.

Day: 1~9, A~Y, for 1st to 31st, exclude I ,O, and U.

Revision Code: Cover all the change

(c) Quantities: 8

10. Packaging

10.1 PACKING SPECIFICATIONS

- (1) 8 LCD TV Panels / 1 Box
- (2) Box dimensions : 1320 (L) X910 (W) X99 (H)mm
- (3) Weight : approximately 39 Kg (8 panels per box)
- (4) 80 LCD TV Panels / 1 Group

10.2 PACKING METHOD

Figures 10-1 and 10-2 are the packing method

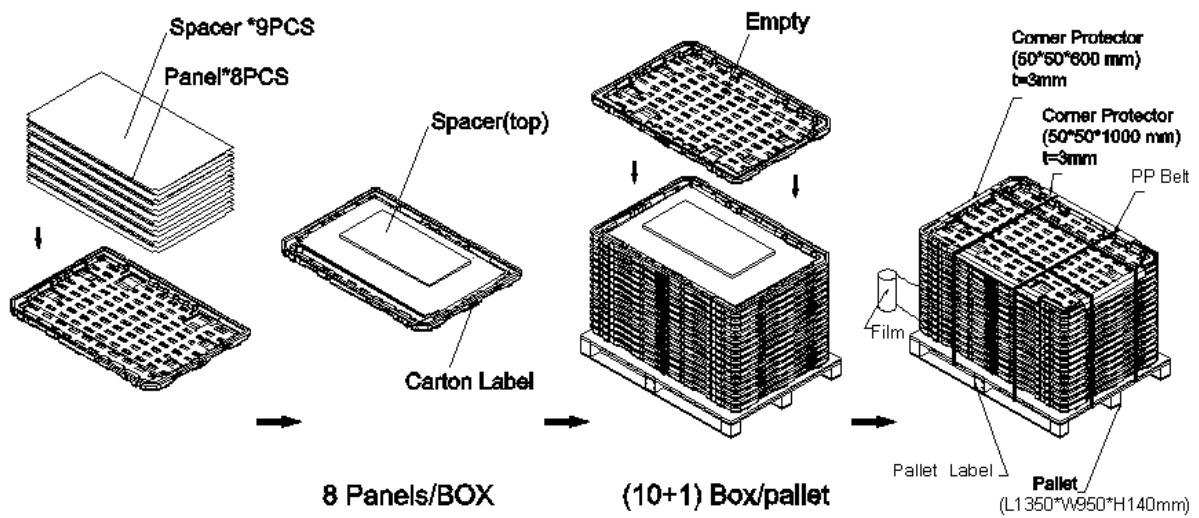
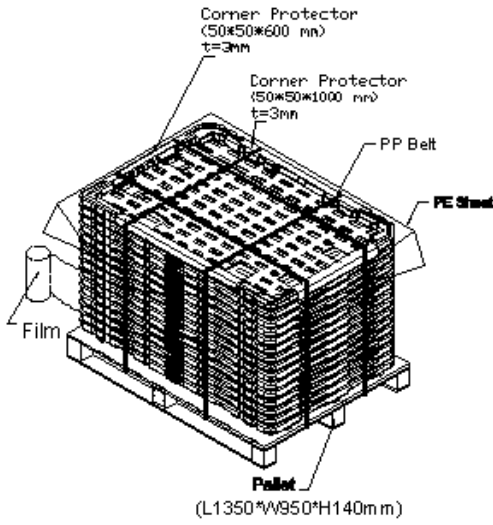

Figure.10-1 packing method

Sea / Land Transportation

Air Transportation



(10+1) Box/pallet

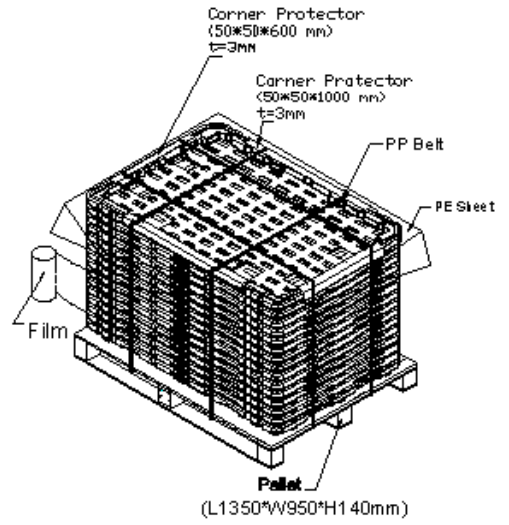

(10+1) Box/pallet

Figure. 10-2 Packing method

11. MECHANICAL CHARACTERISTIC

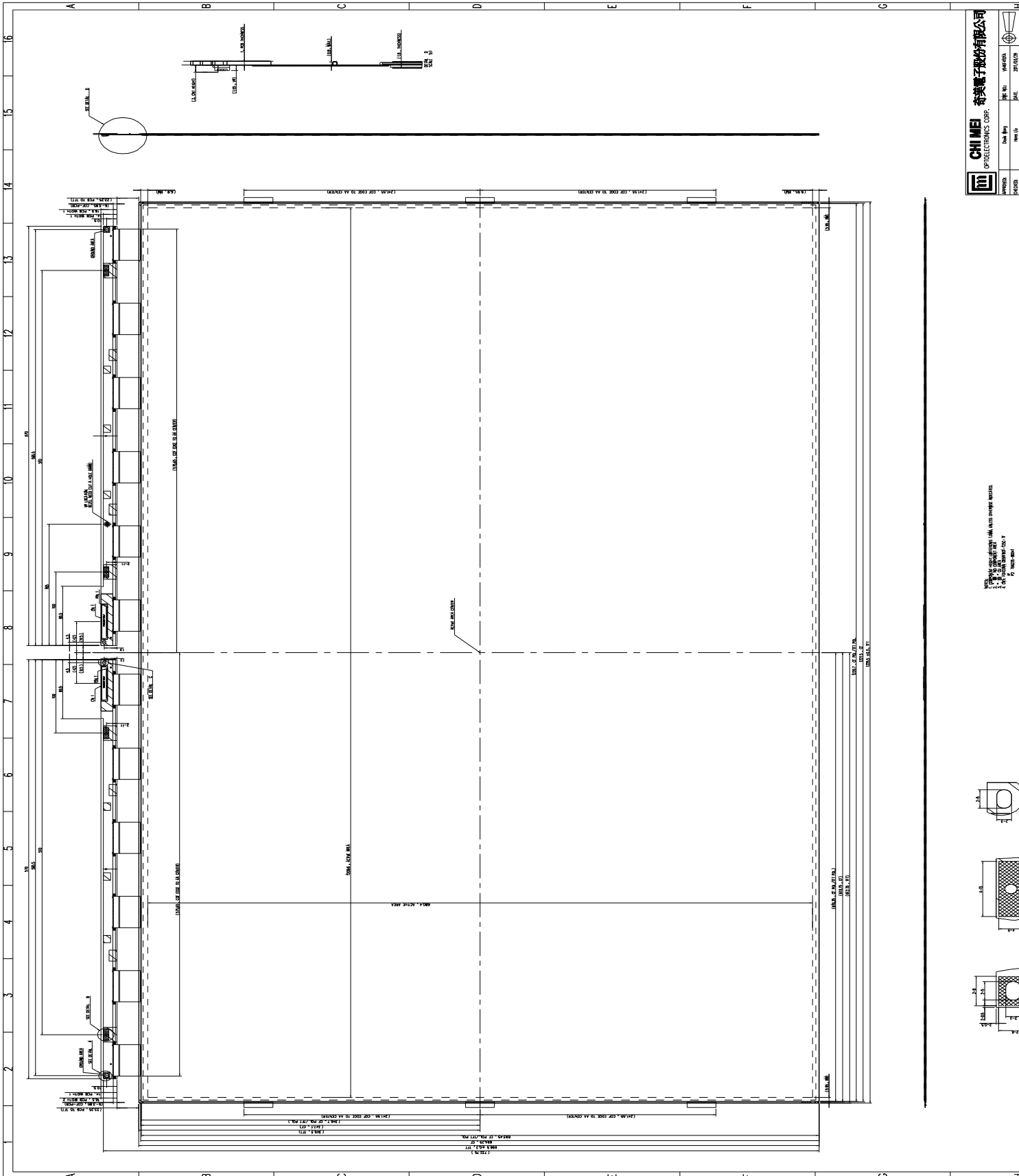

CHI MEI 奇美電子股份有限公司
OPTI-ELECTRONICS CORP.

REVISED	DATE	BY	REASON
1	2012/03/05	WY	INITIAL DESIGN

1. 請參閱本規格書之圖面說明書。
2. 本規格書之圖面說明書如有變更，請參閱本規格書之圖面說明書。
3. 本規格書之圖面說明書如有變更，請參閱本規格書之圖面說明書。

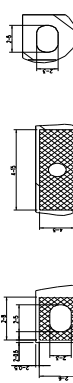

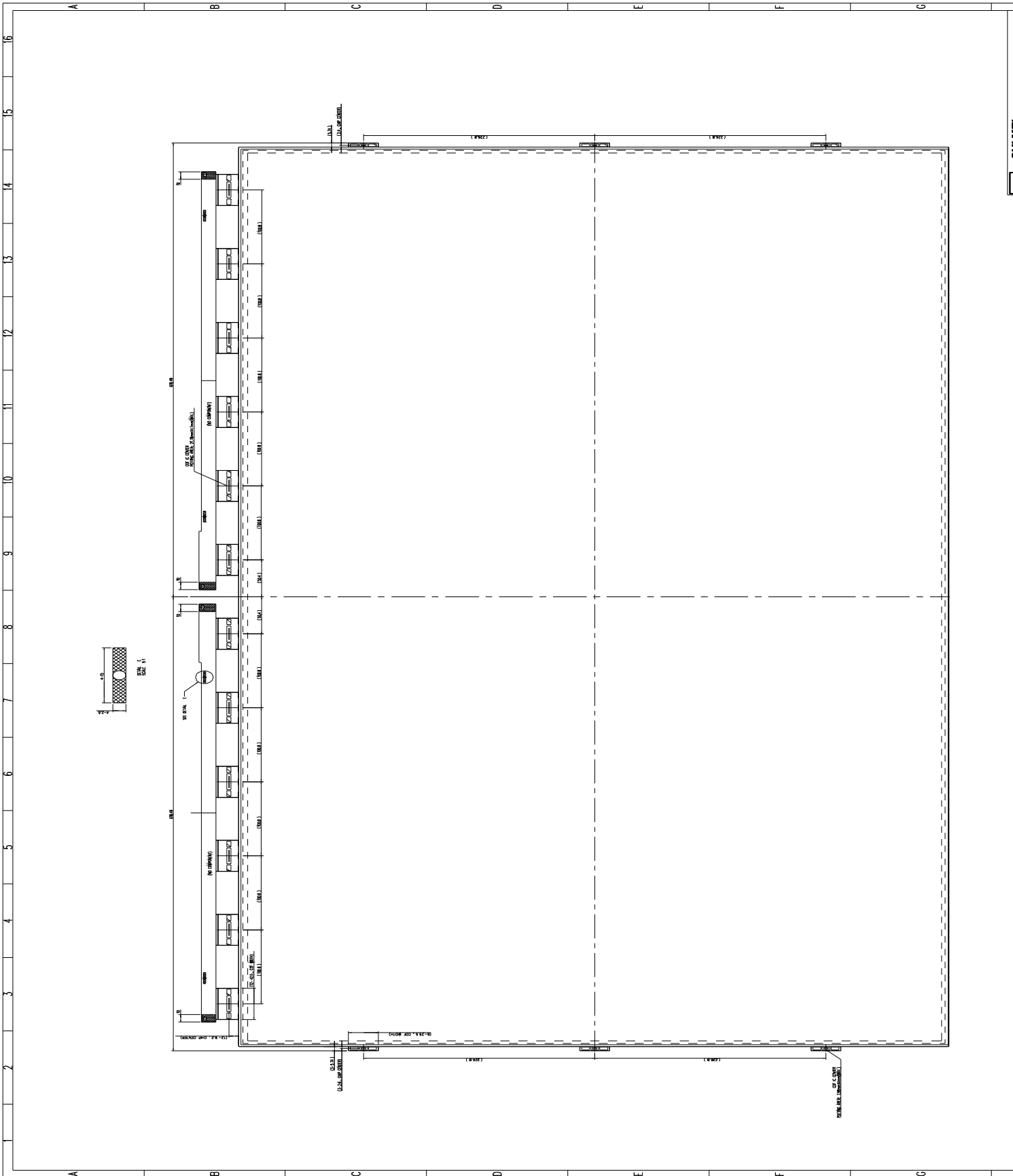

Appendix A

Local Dimming demo function

A.1 I2C address and write command

Device address: 0xe0

Register address: 0x65

Command data: 0x16 0x00 0x00 0x00 0x00 0x00: Local Dimming demo mode OFF (Note 1)

0x16 0x00 0x00 0x00 0x00 0x01: Local Dimming demo mode ON (Demo in right half screen) (Note 2)

Preamble data: 0x26 0238

I2C data:

	Device Address		Preamble data		Preamble data	
START	11100000 (0xE0)	ACK	00100110 (0x26)	ACK	00111000 (0x38)	ACK

Register Address		Command Data		Command Data	
01100101 (0x65)	ACK	00010110 (0x16)	ACK	00000000 (0x00)	ACK

Command Data		Command Data		Command Data	
00000000 (0x00)	ACK	00000000 (0x00)	ACK	00000000 (0x00)	ACK

Command Data	
00000001 (0x01)	STOP

Note 1: Local Dimming demo OFF



Note 2: Local Dimming demo ON



A.2 I2C timing

Symbol	Parameter	Min.	Max.	Unit
t_{SU-STA}	Start setup time	250	-	ns
t_{HD-STA}	Start hold time	250	-	ns
t_{SU-DAT}	Data setup time	80	-	ns
t_{HD-DAT}	Data hold time	0	-	ns
t_{SU-STO}	Stop setup time	250	-	ns
t_{BUF}	Time between Stop condition and next Start condition	500	-	ns

