

- Tentative Specification
 Preliminary Specification
 Approval Specification

MODEL NO.: V580HK1

SUFFIX: LD6

Ver. C1

Customer :	
APPROVED BY	SIGNATURE
Name / Title _____	
Note _____	
Please return 1 copy for your confirmation with your signature and comments.	

Approved By	Checked By	Prepared By
Chao-Chun Chung	Perry Lin	Jack Yen

CONTENTS

CONTENTS	2
REVISION HISTORY	4
1. GENERAL DESCRIPTION.....	5
1.1 OVERVIEW	5
1.2 FEATURES.....	5
1.3 APPLICATION.....	5
1.4 GENERAL SPECIFICATIONS	5
1.5 MECHANICAL SPECIFICATIONS.....	6
2. ABSOLUTE MAXIMUM RATINGS	7
2.1 ABSOLUTE RATINGS OF ENVIRONMENT	7
2.2 PACKAGE STORAGE	8
2.3 ELECTRICAL ABSOLUTE RATINGS	8
2.3.1 TFT LCD MODULE.....	8
2.3.2 BACKLIGHT CONVERTER UNIT	8
3. ELECTRICAL CHARACTERISTICS.....	9
3.1 TFT LCD MODULE (Ta = 25 ± 2 °C).....	9
3.2 BACKLIGHT UNIT.....	11
3.2.1 LED LIGHT BAR CHARACTERISTICS	11
4. BLOCK DIAGRAM OF INTERFACE	12
4.1 TFT LCD MODULE	12
5.INPUT TERMINAL PIN ASSIGNMENT.....	13
5.1 TFT LCD MODULE	13
5.2 BACKLIGHT UNIT.....	18
5.3 LVDS INTERFACE	19
5.4 COLOR DATA INPUT ASSIGNMENT	20
6. INTERFACE TIMING.....	21
6.1 INPUT SIGNAL TIMING SPECIFICATIONS.....	21
6.1.1 Timing spec for Frame Rate = 100Hz.....	21
6.1.2 Timing spec for Frame Rate = 120Hz.....	21

6.2 POWER ON/OFF SEQUENCE.....	24
7. OPTICAL CHARACTERISTICS.....	26
7.1 TEST CONDITIONS	26
7.2 OPTICAL SPECIFICATIONS.....	27
8. PRECAUTIONS.....	30
8.1 ASSEMBLY AND HANDLING PRECAUTIONS.....	30
8.2 SAFETY PRECAUTIONS	30
8.3 SAFETY STANDARDS	30
9. DEFINITION OF LABELS.....	31
9.1 CMI MODULE LABEL	31
10. PACKAGING	32
10.1 PACKAGING SPECIFICATIONS.....	32
10.2 PACKAGING METHOD	32
11. MECHANICAL CHARACTERISTIC.....	34

REVISION HISTORY

Version	Date	Page(New)	Section	Description
V 0.0	Aug. 16, 2012	All	All	Tentative Specification was first issued.

1. GENERAL DESCRIPTION

1.1 OVERVIEW

V580HK1-LD6 is a 58" TFT Liquid Crystal Display module with LED Backlight unit and 4ch-LVDS interface. This module supports 1920 x 1080 Full HDTV format and can display true 1.07G colors (8-bits+FRC). The driving board module for backlight is built-in.

1.2 FEATURES

- High brightness 350nits
- High contrast ratio 4000:1
- Fast response time Gray to Gray typical 6.5ms
- High color saturation NTSC 72%
- Full HDTV (1920 x 1080 pixels) resolution, true HDTV format
- DE (Data Enable) only mode
- LVDS (Low Voltage Differential Signaling) interface
- Optimized response time for 120 Hz frame rate
- Viewing Angle : 178(H)/178(V) (CR>20) VA Technology
- Ultra wide viewing angle: Super MVA technology
- RoHs compliance
- T-con input frame rate: 100Hz/120Hz, output frame rate: 100Hz/120Hz

1.3 APPLICATION

- Standard Living Room TVs.
- Public Display Application.
- Home Theater Application.
- MFM Application.

1.4 GENERAL SPECIFICATIONS

Item	Specification	Unit	Note
Active Area	1270.08(H) x 721.44(V) (58" diagonal)	mm	(1)
Bezel Opening Area	1275.3 (H) x 726.7(V)	mm	
Driver Element	a-si TFT active matrix	-	-
Pixel Number	1920 x R.G.B. x 1080	pixel	-
Pixel Pitch(Sub Pixel)	0.2205(H) x 0.6680(V)	mm	-
Pixel Arrangement	RGB vertical stripe	-	-
Display Colors	1.07G(8-bit+FRC)	color	-
Display Operation Mode	Transmissive mode / Normally black	-	-
Surface Treatment	Anti-Glare coating (Haze 1%)	-	(2)
Rotation Function	Unachievable		(3)
Display Orientation	Signal input with "CMI"		(3)

Note (1) Please refer to the attached drawings in chapter 9 for more information about the front and back outlines.

Note (2) The spec of the surface treatment is temporarily for this phase. CMI reserves the rights to change this feature.

Note (3)

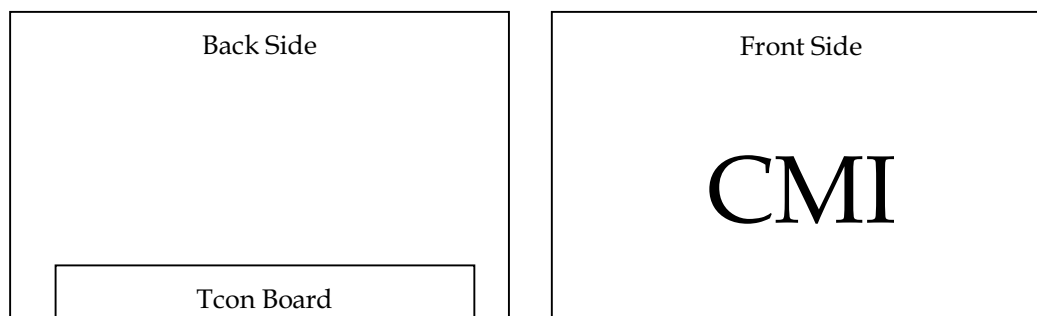

1.5 MECHANICAL SPECIFICATIONS

Item		Min.	Typ.	Max.	Unit	Note
Module Size Weight	Horizontal (H)	1288.8	1290.3	1291.8	mm	(1), (2)
	Vertical (V)	743.2	744.7	746.2	mm	(1), (2)
	Depth (D)	50.3	51.8	53.3	mm	To Rear
		60.8	62.3	63.8	mm	To converter cover
	Weight		16.15		Kg	

Note (1) Please refer to the attached drawings for more information of front and back outline dimensions.

Note (2) Module Depth does not include connectors.

2. ABSOLUTE MAXIMUM RATINGS

2.1 ABSOLUTE RATINGS OF ENVIRONMENT

Item	Symbol	Value		Unit	Note
		Min.	Max.		
Storage Temperature	T _{ST}	-20	+60	°C	(1)
Operating Ambient Temperature	T _{OP}	0	50	°C	(1), (2)
Shock (Non-Operating)	S _{NOF}	-	30	G	(3), (5)
Vibration (Non-Operating)	V _{NOF}	-	1.0	G	(4), (5)

Note (1) Temperature and relative humidity range is shown in the figure below.

(a) 90 %RH Max. ($T_a \leq 40$ °C).

(b) Wet-bulb temperature should be 39 °C Max. ($T_a > 40$ °C).

(c) No condensation.

Note (2) Thermal management should be considered in final product design to prevent the surface temperature of display area from being over 65 °C. The range of operating temperature may degrade in case of improper thermal management in final product design.

Note (3) 11 ms, half sine wave, 1 time for $\pm X$, $\pm Y$, $\pm Z$.

Note (4) 10 ~ 200 Hz, 10 min, 1 time each X, Y, Z.

Note (5) At testing Vibration and Shock, the fixture in holding the module has to be hard and rigid enough so that the module would not be twisted or bent by the fixture.

Relative Humidity (%RH)

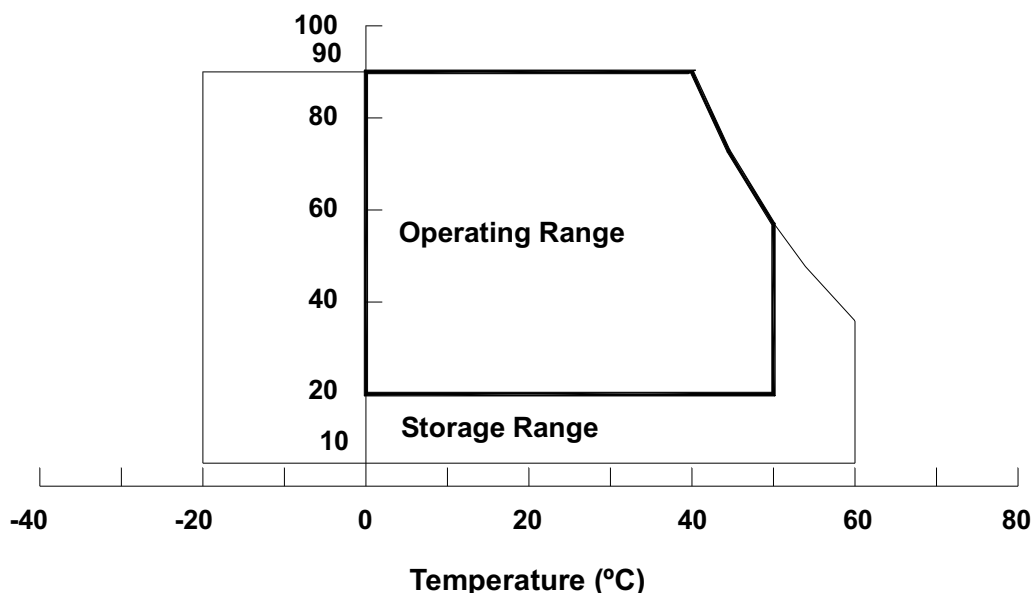

2.2 PACKAGE STORAGE

When storing modules as spares for a long time, the following precaution is necessary.

- (a) Do not leave the module in high temperature, and high humidity for a long time, It is highly recommended to store the module with temperature from 0 to 35 °C at normal humidity without condensation.
- (b) The module shall be stored in dark place. Do not store the TFT-LCD module in direct sunlight or fluorescent light.

2.3 ELECTRICAL ABSOLUTE RATINGS

2.3.1 TFT LCD MODULE

Item	Symbol	Value		Unit	Note
		Min.	Max.		
Power Supply Voltage	V _{CC}	-0.3	13.5	V	(1)
Logic Input Voltage	V _{IN}	-0.3	3.6	V	

2.3.2 BACKLIGHT CONVERTER UNIT

Item	Symbol	Test Condition	Min.	Type	Max.	Unit	Note
Light Bar Voltage	V _W	Ta = 25 °C	-	-	165	V _{DC}	(1)

Note (1) Permanent damage to the device may occur if maximum values are exceeded. Function operation should be restricted to the conditions described under Normal Operating Conditions.

3. ELECTRICAL CHARACTERISTICS

3.1 TFT LCD MODULE (Ta = 25 ± 2 °C)

Parameter	Symbol	Value			Unit	Note	
		Min.	Typ.	Max.			
Power Supply Voltage	V _{CC}	10.8	12	13.2	V	(1)	
Rush Current	I _{RUSH}	—	—	3.51	A	(2)	
Power Consumption	White Pattern	P _T	—	6.05	7.22	W	(3)
	Horizontal Stripe	P _T	—	18.32	21.99	W	
	Black Pattern	P _T	—	5.73	6.86	W	
Power Supply Current	White Pattern	—	—	0.50	0.60	A	(3)
	Horizontal Stripe	—	—	1.53	1.83	A	
	Black Pattern	—	—	0.48	0.57	A	
LVDS interface	Differential Input High Threshold Voltage	V _{LVTH}	+100	—	+300	mV	(4)
	Differential Input Low Threshold Voltage	V _{LVTL}	-300	—	-100	mV	
	Common Input Voltage	V _{CM}	1.0	1.2	1.4	V	
	Differential input voltage (single-end)	V _{ID}	200	—	600	mV	
	Terminating Resistor	R _T	—	100	—	ohm	
CMIS interface	Input High Threshold Voltage	V _{IH}	2.7	—	3.3	V	
	Input Low Threshold Voltage	V _{IL}	0	—	0.7	V	

Note (1) The module should be always operated within the above ranges.

The ripple voltage should be controlled under 10% of V_{CC} (Typ.)

Note (2) Measurement condition:

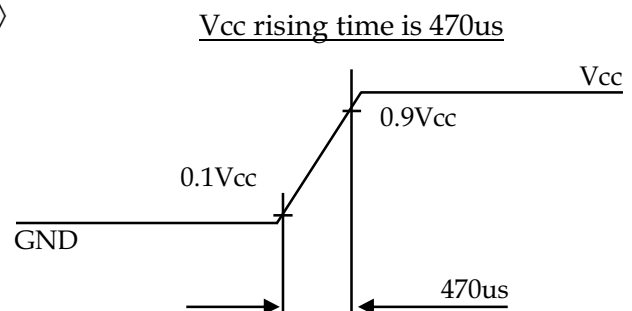
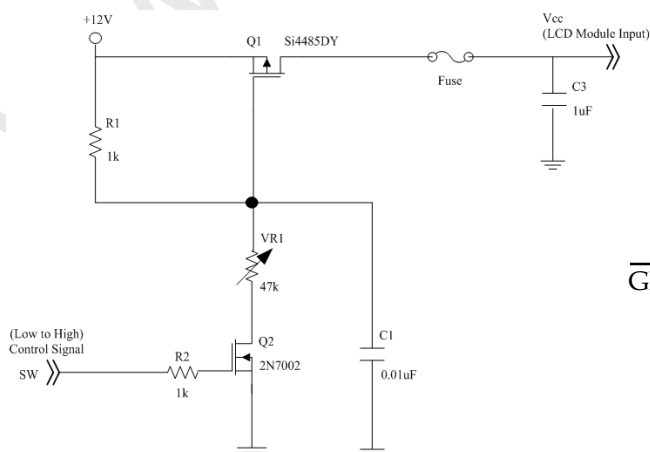

Note (3) The specified power consumption and power supply current is under the conditions at $V_{CC} = 12\text{ V}$, $T_a = 25 \pm 2\text{ }^\circ\text{C}$, $f_v = 120\text{ Hz}$, whereas a power dissipation check pattern below is displayed.

a. White Pattern



Active Area

b. Black Pattern

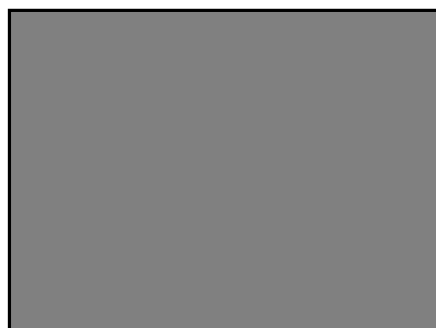

Active Area

c. Horizontal Pattern

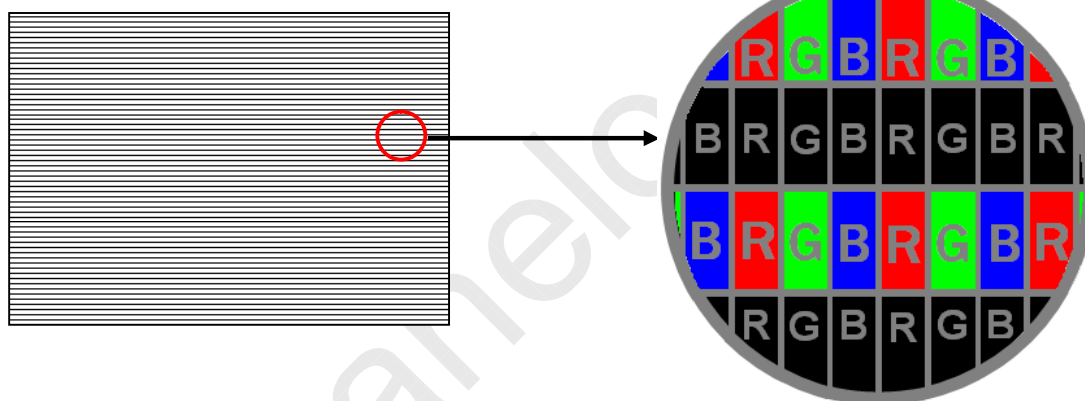

Note (4) The LVDS input characteristics is as below :

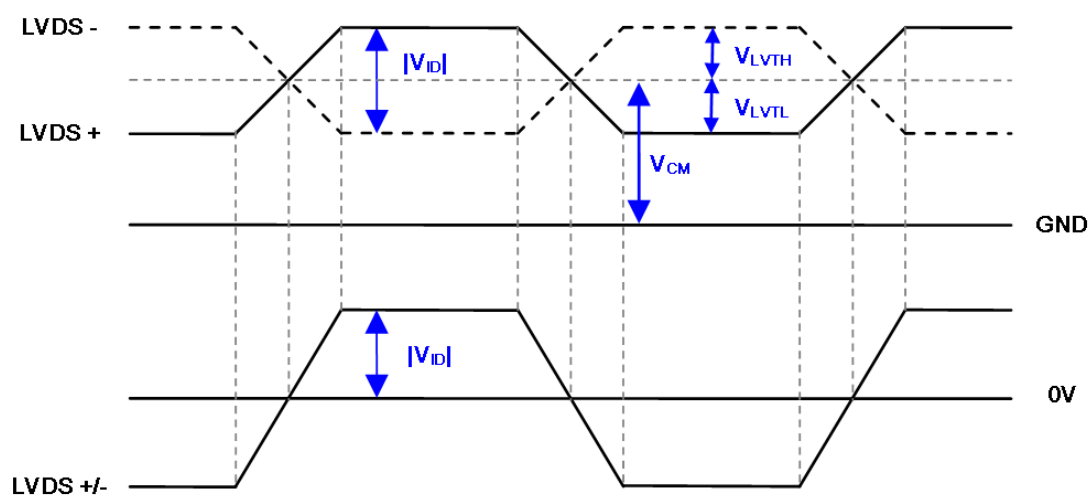

3.2 BACKLIGHT UNIT

3.2.1 LED LIGHT BAR CHARACTERISTICS

The backlight unit contains 5 pcs LED light bar, and each light bar has 1 string LED. (Ta = 25 ± 2 °C)

Parameter	Symbol	Value			Unit	Note
		Min.	Typ.	Max.		
One String Current	I _L	159.8	170	180.2	mA	
One String Voltage	V _W	132.48	148.005	163.53	V _{DC}	I _L =170mA
One String Voltage Variation	ΔV _W	-	-	2.95	V	For 1 BLU I _L =170mA
Power Consumption	P _{BL}	118.25	125.8	133.35	W	Only LEDs Duty=100% I _L =170mA
Life time	-	30,000	-	-	Hrs	(1)

Note (1) The lifetime is defined as the time which luminance of the LED decays to 50% compared to the initial value,

Operating condition: Continuous operating at Ta = 25±2°C, I_L =170mA.

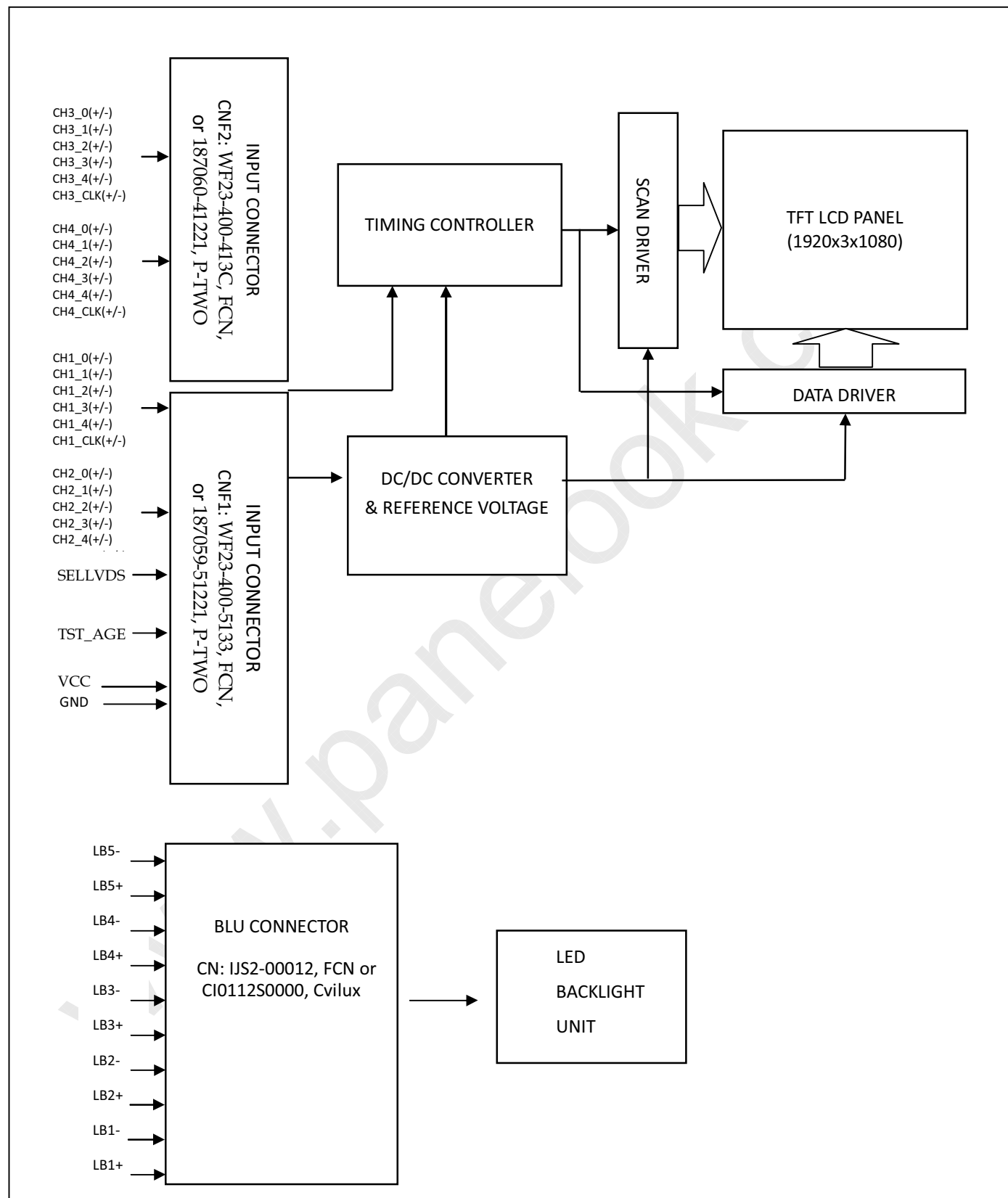
4. BLOCK DIAGRAM OF INTERFACE
4.1 TFT LCD MODULE

5.INPUT TERMINAL PIN ASSIGNMENT

5.1 TFT LCD MODULE

CNF1 Connector Pin Assignment (WF23-400-5133, FCN or 187059-51221, P-TWO)

Pin	Name	Description	Note
1	N.C.	No Connection	(1)
2	N.C.	No Connection	(1)
3	N.C.	No Connection	(1)
4	N.C.	No Connection	(1)
5	N.C.	No Connection	(1)
6	N.C.	No Connection	(1)
7	SELLVDS	Input signal for LVDS Data Format Selection	(2), (3)
8	N.C.	No Connection	(1)
9	N.C.	No Connection	
10	N.C.	No Connection	
11	GND	Ground	
12	CH1[0]-	First pixel Negative LVDS differential data input. Pair 0	(4)
13	CH1[0]+	First pixel Positive LVDS differential data input. Pair 0	
14	CH1[1]-	First pixel Negative LVDS differential data input. Pair 1	
15	CH1[1]+	First pixel Positive LVDS differential data input. Pair 1	
16	CH1[2]-	First pixel Negative LVDS differential data input. Pair 2	
17	CH1[2]+	First pixel Positive LVDS differential data input. Pair 2	
18	GND	Ground	
19	CH1CLK-	First pixel Negative LVDS differential clock input.	(4)
20	CH1CLK+	First pixel Positive LVDS differential clock input.	
21	GND	Ground	
22	CH1[3]-	First pixel Negative LVDS differential data input. Pair 3	(4)
23	CH1[3]+	First pixel Positive LVDS differential data input. Pair 3	
24	CH1[4]-	First pixel Negative LVDS differential data input. Pair 4	
25	CH1[4]+	First pixel Positive LVDS differential data input. Pair 4	
26	N.C.	No Connection	(1)
27	N.C.	No Connection	(1)
28	CH2[0]-	Second pixel Negative LVDS differential data input. Pair 0	(4)
29	CH2[0]+	Second pixel Positive LVDS differential data input. Pair 0	

30	CH2[1]-	Second pixel Negative LVDS differential data input. Pair 1	
31	CH2[1]+	Second pixel Positive LVDS differential data input. Pair 1	
32	CH2[2]-	Second pixel Negative LVDS differential data input. Pair 2	
33	CH2[2]+	Second pixel Positive LVDS differential data input. Pair 2	
34	GND	Ground	
35	CH2CLK-	Second pixel Negative LVDS differential clock input.	(4)
36	CH2CLK+	Second pixel Positive LVDS differential clock input.	
37	GND	Ground	
38	CH2[3]-	Second pixel Negative LVDS differential data input. Pair 3	(4)
39	CH2[3]+	Second pixel Positive LVDS differential data input. Pair 3	
40	CH2[4]-	Second pixel Negative LVDS differential data input. Pair 4	
41	CH2[4]+	Second pixel Positive LVDS differential data input. Pair 4	
42	N.C.	No Connection	(1)
43	N.C.	No Connection	(1)
44	GND	Ground	
45	GND	Ground	
46	GND	Ground	
47	N.C.	No Connection	(1)
48	VCC	+12V power supply	
49	VCC	+12V power supply	
50	VCC	+12V power supply	
51	VCC	+12V power supply	

CNF2 Connector Pin Assignment (CNF2 : WF23-400-413C, FCN or 187060-41221, P-TWO)

Pin	Name	Description	Note
1	N.C.	No Connection	(1)
2	N.C.	No Connection	
3	N.C.	No Connection	
4	N.C.	No Connection	
5	N.C.	No Connection	
6	N.C.	No Connection	
7	N.C.	No Connection	(1)
8	N.C.	No Connection	
9	GND	Ground	
10	CH3[0]-	Third pixel Negative LVDS differential data input. Pair 0	(4)
11	CH3[0]+	Third pixel Positive LVDS differential data input. Pair 0	
12	CH3[1]-	Third pixel Negative LVDS differential data input. Pair 1	
13	CH3[1]+	Third pixel Positive LVDS differential data input. Pair 1	
14	CH3[2]-	Third pixel Negative LVDS differential data input. Pair 2	
15	CH3[2]+	Third pixel Positive LVDS differential data input. Pair 2	
16	GND	Ground	
17	CH3CLK-	Third pixel Negative LVDS differential clock input.	(4)
18	CH3CLK+	Third pixel Positive LVDS differential clock input.	
19	GND	Ground	
20	CH3[3]-	Third pixel Negative LVDS differential data input. Pair 3	(4)
21	CH3[3]+	Third pixel Positive LVDS differential data input. Pair 3	
22	CH3[4]-	Third pixel Negative LVDS differential data input. Pair 4	
23	CH3[4]+	Third pixel Positive LVDS differential data input. Pair 4	
24	GND	Ground	
25	GND	Ground	
26	CH4[0]-	Fourth pixel Negative LVDS differential data input. Pair 0	(4)
27	CH4[0]+	Fourth pixel Positive LVDS differential data input. Pair 0	
28	CH4[1]-	Fourth pixel Negative LVDS differential data input. Pair 1	
29	CH4[1]+	Fourth pixel Positive LVDS differential data input. Pair 1	
30	CH4[2]-	Fourth pixel Negative LVDS differential data input. Pair 2	

31	CH4[2]+	Fourth pixel Positive LVDS differential data input. Pair 2	
32	GND	Ground	
33	CH4CLK-	Fourth pixel Negative LVDS differential clock input.	(4)
34	CH4CLK+	Fourth pixel Positive LVDS differential clock input.	
35	GND	Ground	
36	CH4[3]-	Fourth pixel Negative LVDS differential data input. Pair 3	(4)
37	CH4[3]+	Fourth pixel Positive LVDS differential data input. Pair 3	
38	CH4[4]-	Fourth pixel Negative LVDS differential data input. Pair 4	(4)
39	CH4[4]+	Fourth pixel Positive LVDS differential data input. Pair 4	
40	GND	Ground	
41	GND	Ground	

Note (1) Reserved for internal use. Please leave it open.

Note (2) LVDS format selection.

L= Connect to GND, H=Connect to +3.3V or Open

SELLVDS	Note
L	JEIDA Format
H or Open	VESA Format

Note (3) Interface optional pin has internal scheme as following diagram. Customer should keep the interface voltage level requirement which including Panel board loading as below.

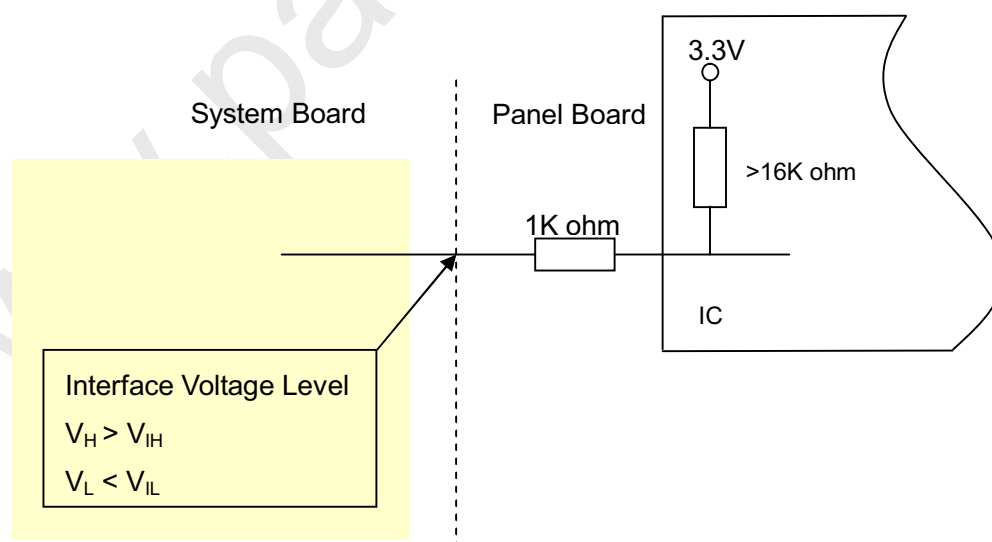

Note (4) LVDS 4-port data mapping

Port	Channel of LVDS	Data Stream
1st Port	First Pixel	1, 5, 9,1913, 1917
2nd Port	Second Pixel	2, 6, 10,1914, 1918
3rd Port	Third Pixel	3, 7, 11,1915, 1919
4th Port	Fourth Pixel	4, 8, 12,1916, 1920

Note (5) LVDS connector pin order defined as follows

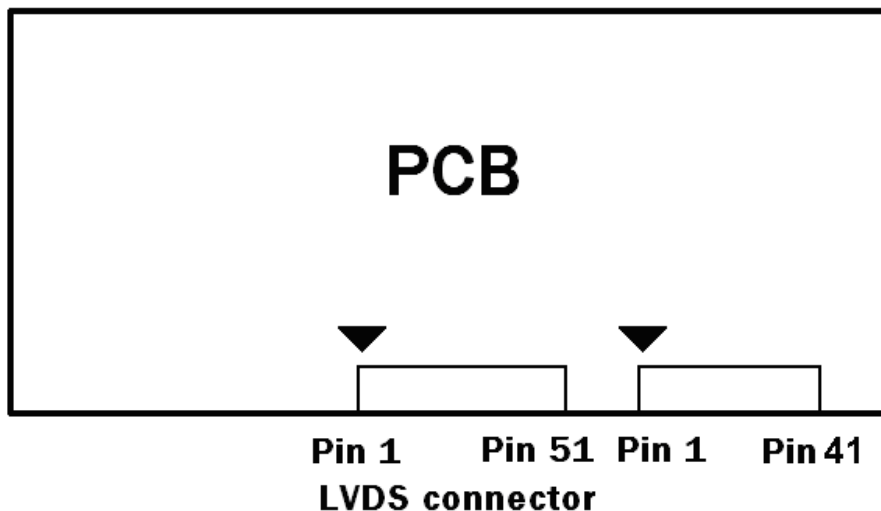

Note (6) LVDS connector mating dimension range request is 0.93mm~1.0mm as below

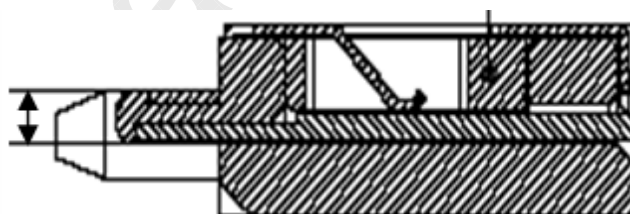

5.2 BACKLIGHT UNIT

The pin configuration for the housing and leader wire is shown in the table below.

CN: JH2-01-122N (FCN)

Pin No	Symbol	Feature
1	LB5-	Negative of Light Bar 5
2	LB4-	Negative of Light Bar 4
3	LB3-	Negative of Light Bar 3
4	LB2-	Negative of Light Bar 2
5	LB1-	Negative of Light Bar 1
6	NC	No Connection
7	NC	No Connection
8	LB5+	Positive of Light Bar 5
9	LB4+	Positive of Light Bar 4
10	LB3+	Positive of Light Bar 3
11	LB2+	Positive of Light Bar 2
12	LB1+	Positive of Light Bar 1

5.3 LVDS INTERFACE

JEIDA Format : SELLVDS = L

VESA Format : SELLVDS = H or Open

VESA LVDS format

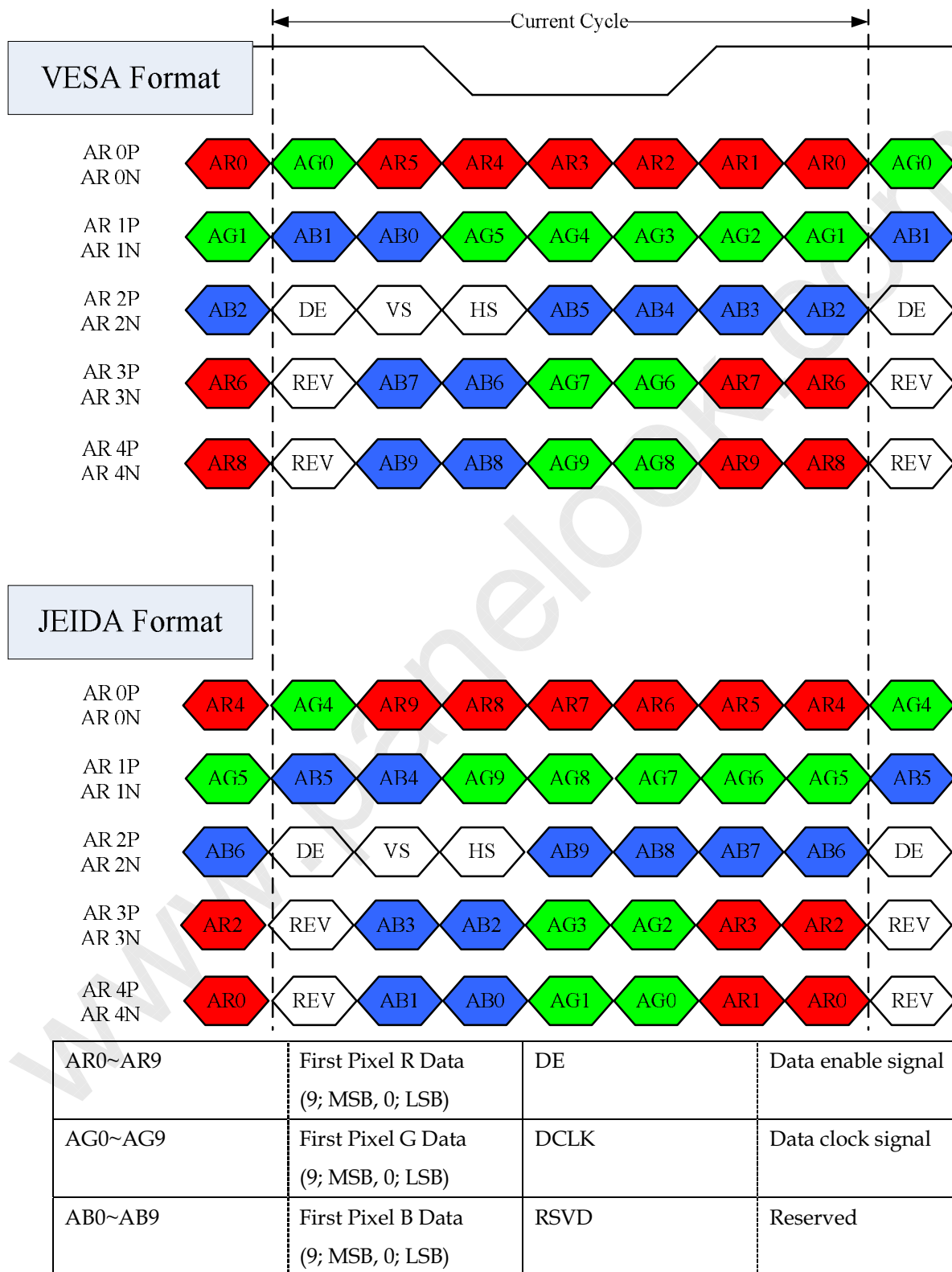

5.4 COLOR DATA INPUT ASSIGNMENT

The brightness of each primary color (red, green and blue) is based on the 10-bit gray scale data input for the color. The higher the binary input the brighter the color. The table below provides the assignment of color versus data input.

Color		Data Signal																											
		Red										Green										Blue							
		R9	R8	R7	R6	R5	R4	R3	R2	R1	R0	G9	G8	G7	G6	G5	G4	G3	G2	G1	G0	B9	B8	B7	B6	B5	B4	B3	B2
Basic Colors	Black	0	0	0	0	0	0	0	0	0	0	0	0	0	0	0	0	0	0	0	0	0	0	0	0	0	0	0	0
	Red	1	1	1	1	1	1	1	1	1	1	0	0	0	0	0	0	0	0	0	0	0	0	0	0	0	0	0	0
	Green	0	0	0	0	0	0	0	0	0	0	1	1	1	1	1	1	1	1	1	1	1	0	0	0	0	0	0	0
	Blue	0	0	0	0	0	0	0	0	0	0	0	0	0	0	0	0	0	0	0	0	1	1	1	1	1	1	1	1
	Cyan	0	0	0	0	0	0	0	0	0	0	1	1	1	1	1	1	1	1	1	1	1	1	1	1	1	1	1	1
	Magenta	1	1	1	1	1	1	1	1	1	1	0	0	0	0	0	0	0	0	0	0	1	1	1	1	1	1	1	1
	Yellow	1	1	1	1	1	1	1	1	1	1	1	1	1	1	1	1	1	1	1	1	1	0	0	0	0	0	0	0
	White	1	1	1	1	1	1	1	1	1	1	1	1	1	1	1	1	1	1	1	1	1	1	1	1	1	1	1	1
Gray Scale Of Red	Red (0) / Dark	0	0	0	0	0	0	0	0	0	0	0	0	0	0	0	0	0	0	0	0	0	0	0	0	0	0	0	
	Red (1)	0	0	0	0	0	0	0	0	0	1	0	0	0	0	0	0	0	0	0	0	0	0	0	0	0	0	0	
	Red (2)	0	0	0	0	0	0	0	0	1	0	0	0	0	0	0	0	0	0	0	0	0	0	0	0	0	0	0	
	⋮	⋮	⋮	⋮	⋮	⋮	⋮	⋮	⋮	⋮	⋮	⋮	⋮	⋮	⋮	⋮	⋮	⋮	⋮	⋮	⋮	⋮	⋮	⋮	⋮	⋮	⋮		
	⋮	⋮	⋮	⋮	⋮	⋮	⋮	⋮	⋮	⋮	⋮	⋮	⋮	⋮	⋮	⋮	⋮	⋮	⋮	⋮	⋮	⋮	⋮	⋮	⋮	⋮	⋮		
	Red (1021)	1	1	1	1	1	1	1	1	0	1	0	0	0	0	0	0	0	0	0	0	0	0	0	0	0	0	0	
	Red (1022)	1	1	1	1	1	1	1	1	1	0	0	0	0	0	0	0	0	0	0	0	0	0	0	0	0	0	0	
	Red (1023)	1	1	1	1	1	1	1	1	1	1	0	0	0	0	0	0	0	0	0	0	0	0	0	0	0	0	0	
Gray Scale Of Green	Green (0) / Dark	0	0	0	0	0	0	0	0	0	0	0	0	0	0	0	0	0	0	0	0	0	0	0	0	0	0	0	
	Green (1)	0	0	0	0	0	0	0	0	0	0	0	0	0	0	0	0	0	0	0	1	0	0	0	0	0	0	0	
	Green (2)	0	0	0	0	0	0	0	0	0	0	0	0	0	0	0	0	0	0	0	1	0	0	0	0	0	0	0	
	⋮	⋮	⋮	⋮	⋮	⋮	⋮	⋮	⋮	⋮	⋮	⋮	⋮	⋮	⋮	⋮	⋮	⋮	⋮	⋮	⋮	⋮	⋮	⋮	⋮	⋮	⋮		
	⋮	⋮	⋮	⋮	⋮	⋮	⋮	⋮	⋮	⋮	⋮	⋮	⋮	⋮	⋮	⋮	⋮	⋮	⋮	⋮	⋮	⋮	⋮	⋮	⋮	⋮	⋮		
	Green (1021)	0	0	0	0	0	0	0	0	0	0	1	1	1	1	1	1	1	1	0	1	0	0	0	0	0	0	0	
	Green (1022)	0	0	0	0	0	0	0	0	0	0	1	1	1	1	1	1	1	1	1	0	0	0	0	0	0	0	0	
	Green (1023)	0	0	0	0	0	0	0	0	0	0	1	1	1	1	1	1	1	1	1	1	0	0	0	0	0	0	0	
Gray Scale Of Blue	Blue (0) / Dark	0	0	0	0	0	0	0	0	0	0	0	0	0	0	0	0	0	0	0	0	0	0	0	0	0	0	0	
	Blue (1)	0	0	0	0	0	0	0	0	0	0	0	0	0	0	0	0	0	0	0	0	0	0	0	0	0	0	1	
	Blue (2)	0	0	0	0	0	0	0	0	0	0	0	0	0	0	0	0	0	0	0	0	0	0	0	0	0	0	1	
	⋮	⋮	⋮	⋮	⋮	⋮	⋮	⋮	⋮	⋮	⋮	⋮	⋮	⋮	⋮	⋮	⋮	⋮	⋮	⋮	⋮	⋮	⋮	⋮	⋮	⋮	⋮		
	⋮	⋮	⋮	⋮	⋮	⋮	⋮	⋮	⋮	⋮	⋮	⋮	⋮	⋮	⋮	⋮	⋮	⋮	⋮	⋮	⋮	⋮	⋮	⋮	⋮	⋮	⋮		
	Blue (1021)	0	0	0	0	0	0	0	0	0	0	0	0	0	0	0	0	0	0	0	1	1	1	1	1	1	1	0	1
	Blue (1022)	0	0	0	0	0	0	0	0	0	0	0	0	0	0	0	0	0	0	0	1	1	1	1	1	1	1	1	
	Blue (1023)	0	0	0	0	0	0	0	0	0	0	0	0	0	0	0	0	0	0	0	1	1	1	1	1	1	1	1	

Note (1) 0: Low Level Voltage , 1: High Level Voltage

6. INTERFACE TIMING

6.1 INPUT SIGNAL TIMING SPECIFICATIONS

(Ta = 25 ± 2 °C)

The input signal timing specifications are shown as the following table and timing diagram.

Signal	Item	Symbol	Min.	Typ.	Max.	Unit	Note
LVDS Receiver Clock	Frequency	$F_{clk_{in}}$ (=1/TC)	60	74.25	80	MHz	
	Input cycle to cycle jitter	T_{rcl}	-	-	200	ps	(3)
	Spread spectrum modulation range	$F_{clk_{in_mod}}$	$F_{clk_{in}}-2\%$	-	$F_{clk_{in}}+2\%$	MHz	(4)
	Spread spectrum modulation frequency	F_{SSM}	-	-	200	KHz	
LVDS Receiver Data	Receiver Skew Margin	T_{RSKM}	-400	-	400	ps	(5)

6.1.1 Timing spec for Frame Rate = 100Hz

Signal	Item	Symbol	Min.	Typ.	Max.	Unit	Note	
Frame rate	2D mode	F_{r5}	94	100	106	Hz	(6), (7)	
Vertical Active Display Term	2D Mode	Total	T_v	1090	1350	1395	Th	$T_v=T_{vd}+T_{vb}$
		Display	T_{vd}	1080	1080	1080	Th	—
		Blank	T_{vb}	10	270	315	Th	—
Horizontal Active Display Term	2D Mode	Total	T_h	520	550	670	Tc	$T_h=T_{hd}+T_{hb}$
		Display	T_{hd}	480	480	480	Tc	—
		Blank	T_{hb}	40	70	190	Tc	—

6.1.2 Timing spec for Frame Rate = 120Hz

Signal	Item	Symbol	Min.	Typ.	Max.	Unit	Note	
Frame rate	2D mode	F_{r6}	114	120	126	Hz	(6), (7)	
Vertical Active Display Term	2D Mode	Total	T_v	1090	1125	1395	Th	$T_v=T_{vd}+T_{vb}$
		Display	T_{vd}	1080	1080	1080	Th	—
		Blank	T_{vb}	10	45	315	Th	—
Horizontal Active	2D Mode	Total	T_h	520	550	670	Tc	$T_h=T_{hd}+T_{hb}$
		Display	T_{hd}	480	480	480	Tc	—

Display Term		Blank	Thb	40	70	190	Tc	—
--------------	--	-------	-----	----	----	-----	----	---

Note (1) Since the module is operated in DE only mode, Hsync and Vsync input signals should be set to low logic level. Otherwise, this module would operate abnormally.

Note (2) Please make sure the range of pixel clock has follow the below equation:

$$F_{clkin(max)} \geq Fr_6 \times Tv \times Th$$

$$Fr_5 \times Tv \times Th \geq F_{clkin(min)}$$

INPUT SIGNAL TIMING DIAGRAM

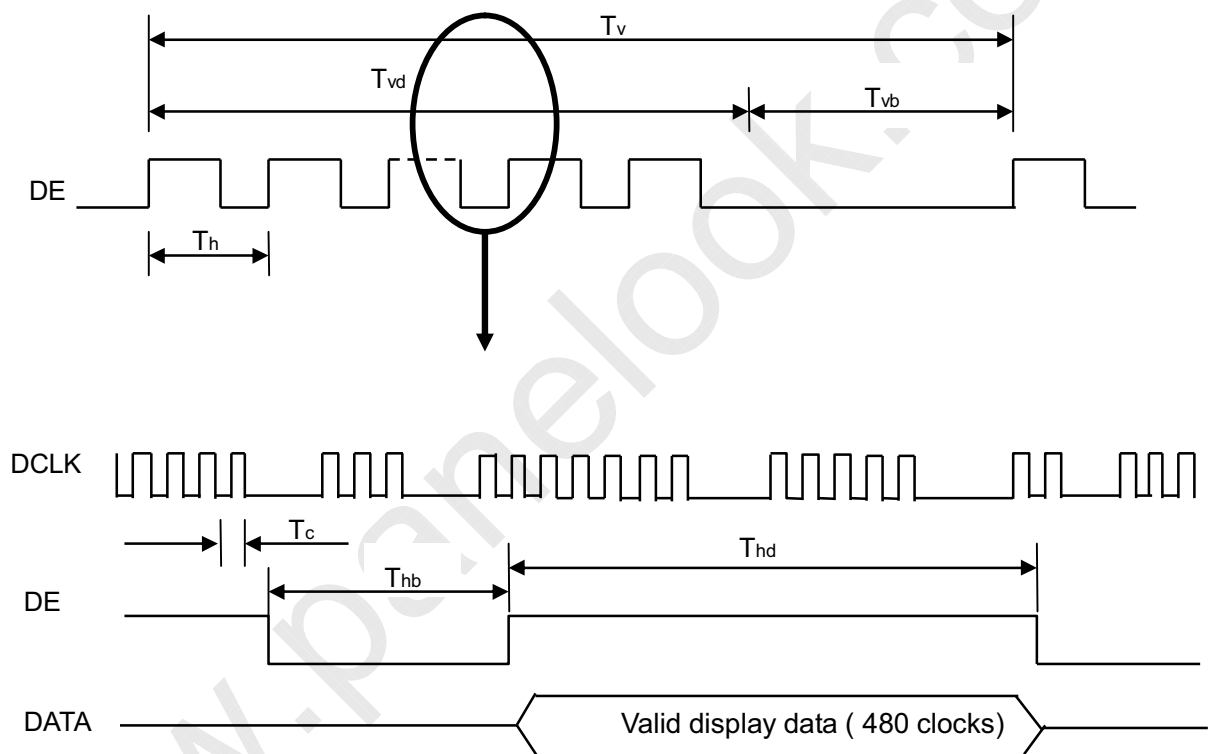

Note (3) The input clock cycle-to-cycle jitter is defined as below figures. $Trcl = |T_1 - T_2|$

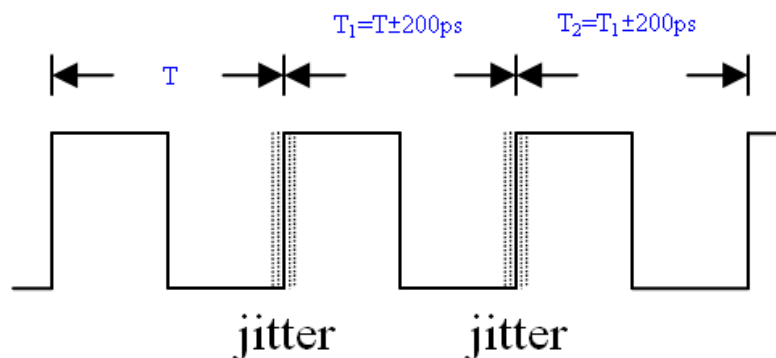

Note (4) The SSCG (Spread spectrum clock generator) is defined as below figures.

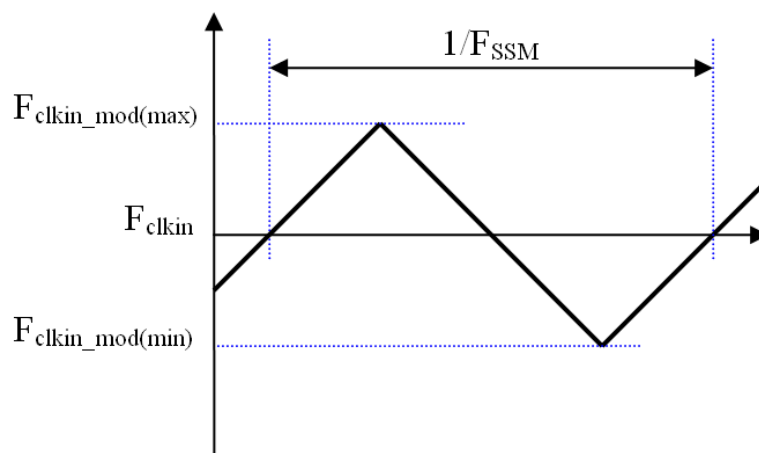

Note (5) LVDS receiver skew margin is defined and shown as below.

LVDS RECEIVER INTERFACE TIMING DIAGRAM

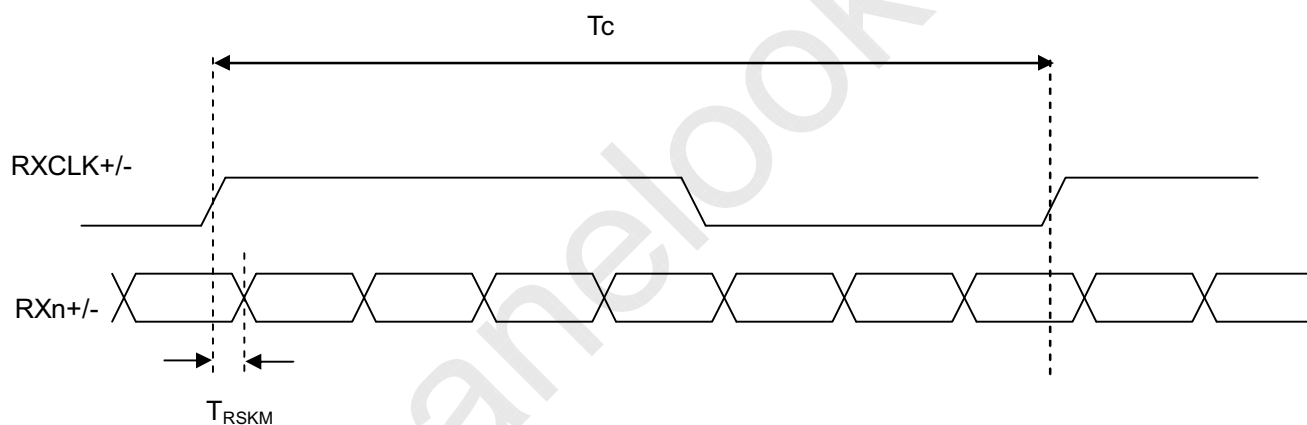

Note (6) The frame-to-frame jitter of the input frame rate is defined as the above figures. $FR_n = FR_{n-1} \pm 1.8\%$.

Note (7) The setup of the frame rate jitter $> 1.8\%$ may result in the cosmetic LED backlight symptom but the electric function is not affected.

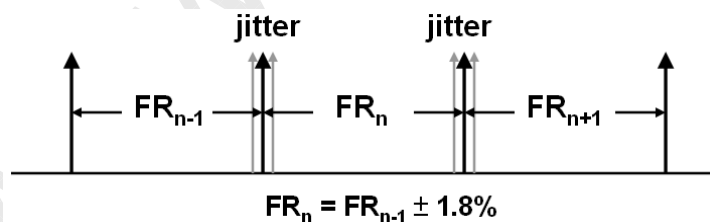

6.2 POWER ON/OFF SEQUENCE

($T_a = 25 \pm 2^\circ\text{C}$)

To prevent a latch-up or DC operation of LCD module, the power on/off sequence should be as the diagram below.

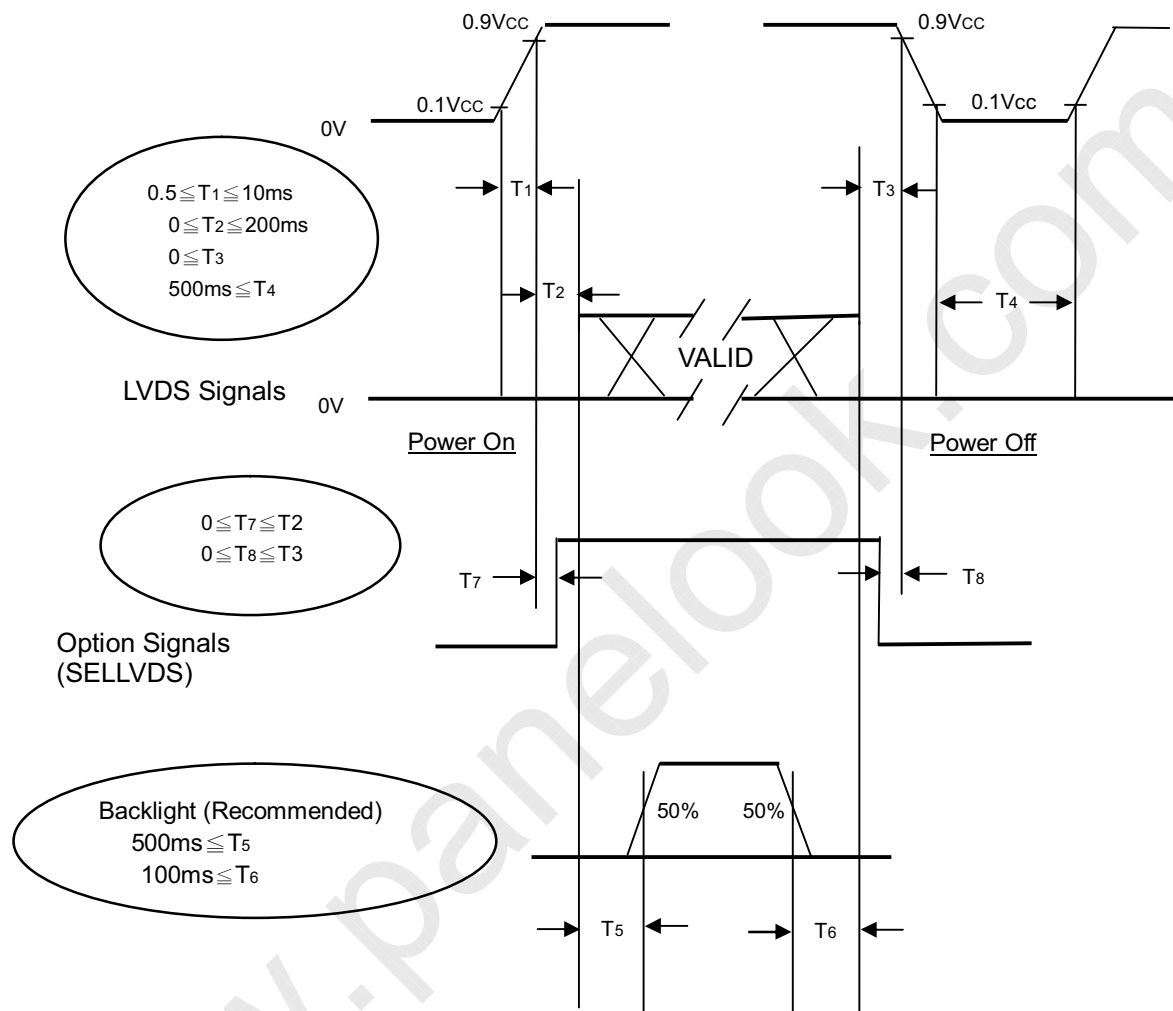

Power ON/OFF Sequence

Vcc Dip
 $T13 \leq 10\text{ms}$

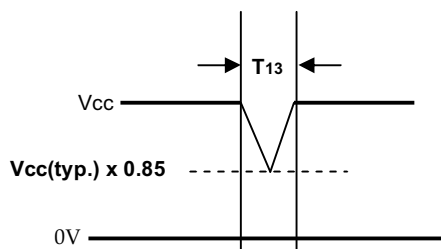

Note (1) The supply voltage of the external system for the module input should follow the definition of Vcc.

Note (2) Apply the LED voltage within the LCD operation range. When the backlight turns on before the LCD operation or the LCD turns off before the backlight turns off, the display may momentarily become abnormal screen.

Note (3) In case of Vcc is in off level, please keep the level of input signals on the low or high impedance. If $T_2 < 0$, that may cause electrical overstress failure.

Note (4) T4 should be measured after the module has been fully discharged between power off and on period.

Note (5) Interface signal shall not be kept at high impedance when the power is on.

Note (6) Vcc must decay smoothly when power-off.

7. OPTICAL CHARACTERISTICS
7.1 TEST CONDITIONS

Item	Symbol	Value	Unit
Ambient Temperature	Ta	25±2	°C
Ambient Humidity	Ha	50±10	%RH
Supply Voltage	V _{CC}	12±1.2	V
Input Signal	According to typical value in "3. ELECTRICAL CHARACTERISTICS"		
LED Current	I _L	170±10.2	mA
Vertical Frame Rate	Fr	120	Hz

The LCD module should be stabilized at given temperature for 1 hour to avoid abrupt temperature change during measuring in a windless room.

Local Dimming Function should be Disable before testing to get the steady optical characteristics (According to 5.1 CNF1 Connector Pin Assignment, Pin no. "42")

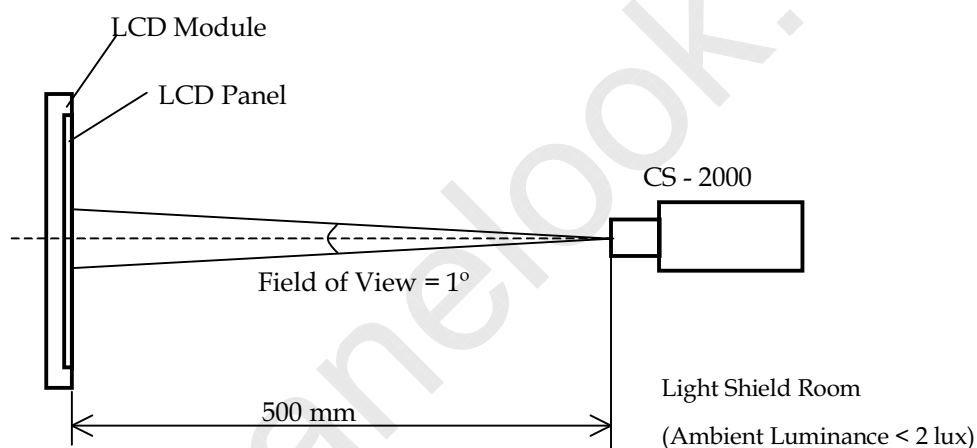

7.2 OPTICAL SPECIFICATIONS

The relative measurement methods of optical characteristics are shown in 7.2. The following items should be measured under the test conditions described in 7.1 and stable environment shown in 7.1.

Item		Symbol	Condition	Min.	Typ.	Max.	Unit	Note	
Contrast Ratio		CR	$\theta_x=0^\circ, \theta_y=0^\circ$ Viewing angle at normal direction	2800	4000	-	-	(2)	
Response Time		Gray to gray			6.5	13	ms	(3)	
Center Luminance of White		L_C		280	350	-	cd/m ²	(4)	
White Variation		δW				1.3	-	(6)	
Cross Talk		CT		-		4	%	(5)	
Color Chromaticity	Red	R _x		Typ.- 0.03	Typ.+ 0.03	0.622	-		
		R _y				0.335	-		
	Green	G _x				0.307	-		
		G _y				0.616	-		
	Blue	B _x				0.149	-		
		B _y	0.055			-			
	White	W _x	0.280			-			
		W _y	0.290			-			
	Correlated color temperature					10000			K
	Color Gamut		C.G.			-	72		-
Viewing Angle	Horizontal	θ_{x+}	CR \geq 20	80	88	-	Deg.	(1)	
		θ_{x-}		80	88	-			
	Vertical	θ_{y+}		80	88	-			
		θ_{y-}		80	88	-			

Note (1) Definition of Viewing Angle (θ_x, θ_y) :

Viewing angles are measured by Autronic Conoscope Cono-80. (or Eldim EZ-Contrast 160R)

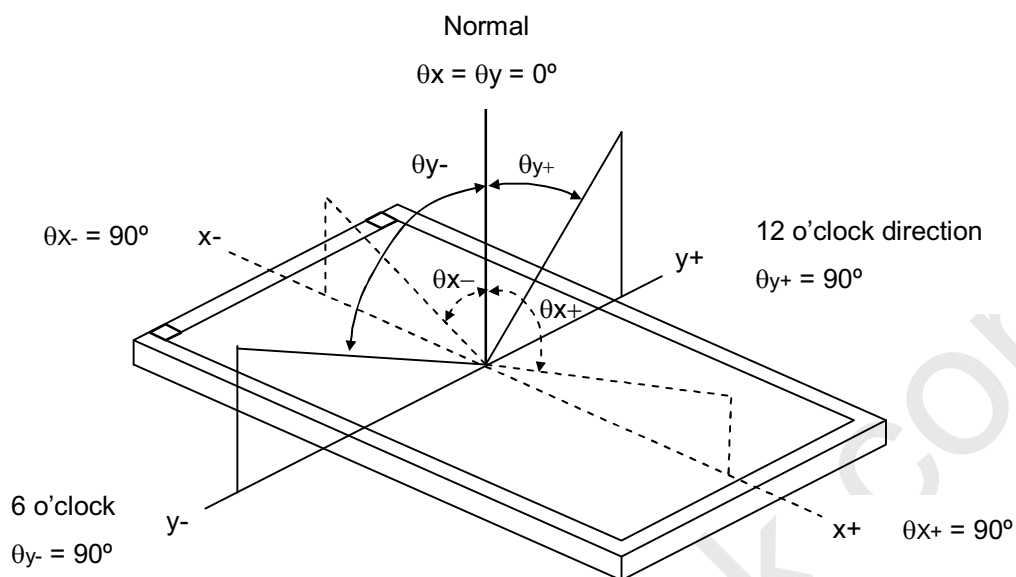

Note (2) Definition of Contrast Ratio (CR) :

The contrast ratio can be calculated by the following expression.

$$\text{Contrast Ratio (CR)} = \frac{\text{Surface Luminance of L1023}}{\text{Surface Luminance of L0}}$$

L1023: Luminance of gray level 1023

L 0: Luminance of gray level 0

CR = CR (5), where CR (X) is corresponding to the Contrast Ratio of the point X at the figure in Note (6).

Note (3) Definition of Gray-to-Gray Switching Time :

Optical Response

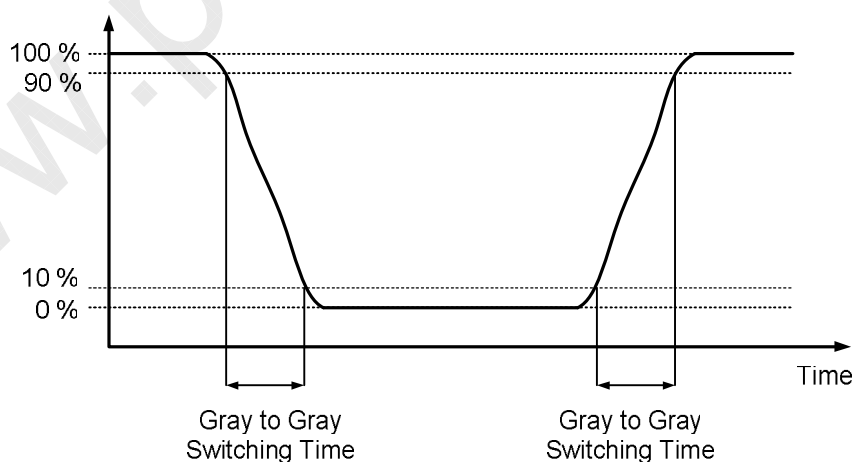

The driving signal means the signal of gray level 0, 124, 252, 380, 508, 636, 764, 892 and 1023.

Gray to gray average time means the average switching time of gray level 0, 124, 252, 380, 508, 636, 764, 892 and 1023 to each other.

Note (4) Definition of Luminance of White (L_C):

Measure the luminance of gray level 1023 at center point.

$L_C = L(5)$, where $L(x)$ is corresponding to the luminance of the point X at the figure in Note (6).

Note (5) Definition of Cross Talk (CT):

$$CT = | Y_B - Y_A | / Y_A \times 100 (\%)$$

Where:

Y_A = Luminance of measured location without gray level 1023 pattern (cd/m²)

Y_B = Luminance of measured location with gray level 1023 pattern (cd/m²)

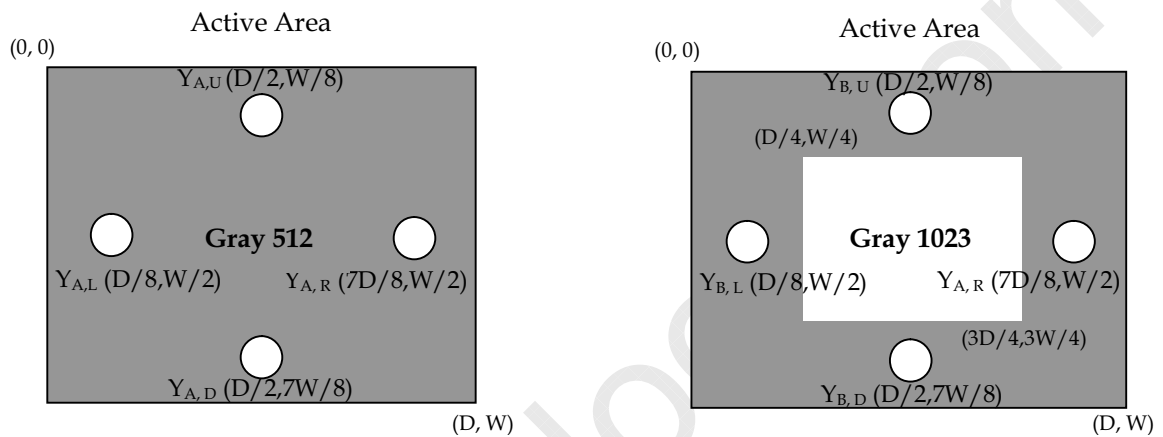

Note (6) Definition of White Variation (δW):

Measure the luminance of gray level 1023 at 5 points

$$\delta W = \frac{\text{Maximum } [L(1), L(2), L(3), L(4), L(5)]}{\text{Minimum } [L(1), L(2), L(3), L(4), L(5)]}$$

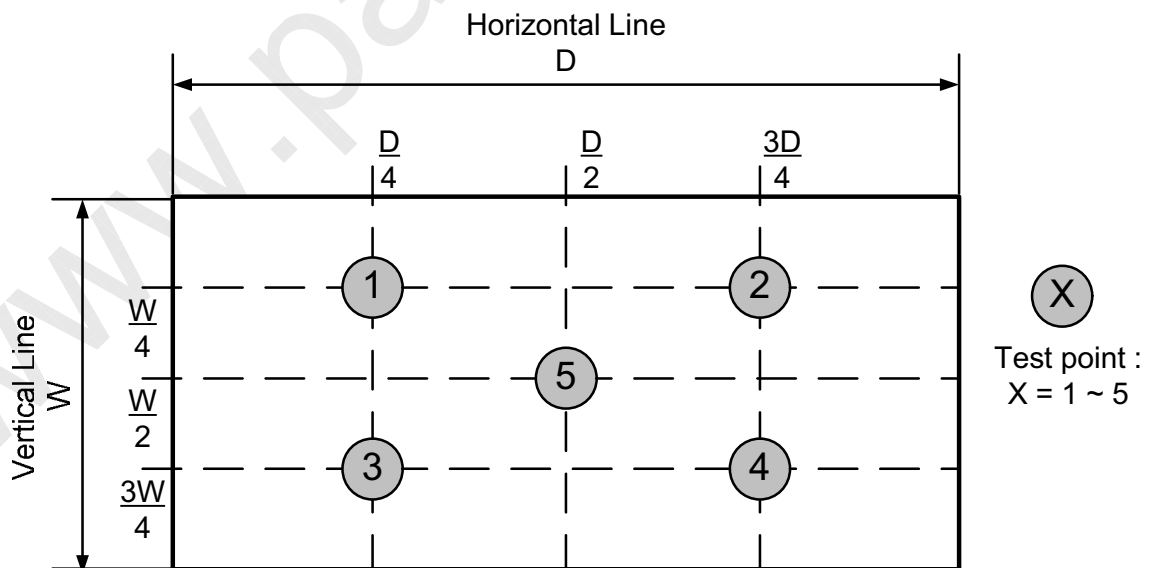

8. PRECAUTIONS

8.1 ASSEMBLY AND HANDLING PRECAUTIONS

- (1) Do not apply rough force such as bending or twisting to the module during assembly.
- (2) It is recommended to assemble or to install a module into the user's system in clean working areas. The dust and oil may cause electrical short or worsen the polarizer.
- (3) Do not apply pressure or impulse to the module to prevent the damage of LCD panel and backlight.
- (4) Always follow the correct power-on sequence when the LCD module is turned on. This can prevent the damage and latch-up of the CMOS LSI chips.
- (5) Do not plug in or pull out the I/F connector while the module is in operation.
- (6) Do not disassemble the module.
- (7) Use a soft dry cloth without chemicals for cleaning, because the surface of polarizer is very soft and easily scratched.
- (8) Moisture can easily penetrate into LCD module and may cause the damage during operation.
- (9) High temperature or humidity may deteriorate the performance of LCD module. Please store LCD modules in the specified storage conditions.
- (10) When ambient temperature is lower than 10°C, the display quality might be reduced. For example, the response time will become slow, and the starting voltage of LED will be higher than that of room temperature.

8.2 SAFETY PRECAUTIONS

- (1) If the liquid crystal material leaks from the panel, it should be kept away from the eyes or mouth. In case of contact with hands, skin or clothes, it has to be washed away thoroughly with soap.
- (2) After the module's end of life, it is not harmful in case of normal operation and storage.

8.3 SAFETY STANDARDS

The LCD module should be certified with safety regulations as follows:

Regulatory	Item	Standard
Information Technology equipment	UL	UL60950-1:2nd Ed.,2011
	cUL	CAN/CSA C22.2 No.60950-1-07,2nd Ed.,2011
	CB	IEC60950-1:2005+A1:2009/ EN60950-1:2006+A11:2009+ A1:2010+A12:2011
Audio/Video Apparatus	UL	UL60065 Ed.7:2007
	cUL	CAN/CSA C22.2 No.60065-03:2006 + A1:2006
	CB	IEC60065:2001+ A1:2005 +A2:2010 / EN60065:2002 + A1:2006 + A11:2008+A2:2010+A12:2011

If the module displays the same pattern for a long period of time, the phenomenon of image sticking may be occurred.

9. DEFINITION OF LABELS

9.1 CMI MODULE LABEL

The barcode nameplate is pasted on each module as illustration, and its definitions are as following explanation.

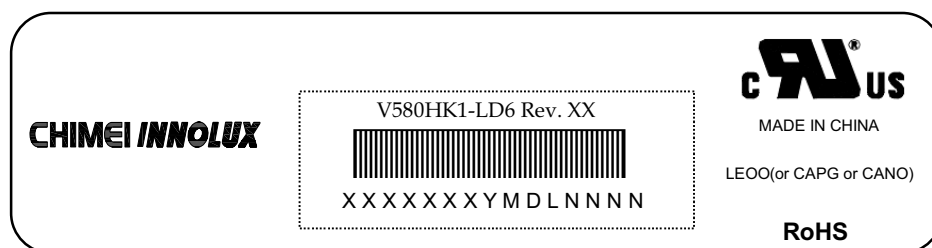

Model Name: V580HK1-LD6

Revision: Rev. XX, for example: A0, A1... B1, B2... or C1, C2...etc.

Serial ID: X X X X X X Y M D L N N N N

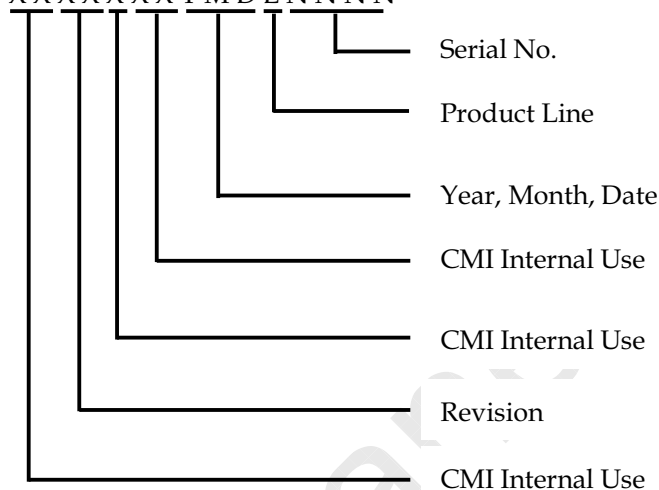

Serial ID includes the information as below:

Manufactured Date:

Year : 2001=1, 2002=2, 2003=3, 2004=4...2010=0, 2011=1, 2012=2...

Month: 1~9, A~C, for Jan. ~ Dec.

Day: 1~9, A~Y, for 1st to 31st, exclude I, O, and U.

Revision Code : Cover all the change

Serial No. : Manufacturing sequence of product

Product Line : 1 → Line1, 2 → Line 2, ...etc.

10. PACKAGING

10.1 PACKAGING SPECIFICATIONS

- (1) 3 LCD TV modules / 1 Box
- (2) Box dimensions: 1448(L) X 283 (W) X 846 (H)
- (3) Weight: approximately 60 Kg (3 modules per box)

10.2 PACKAGING METHOD

Packaging method is shown in following figure 10-1, figure 10-2

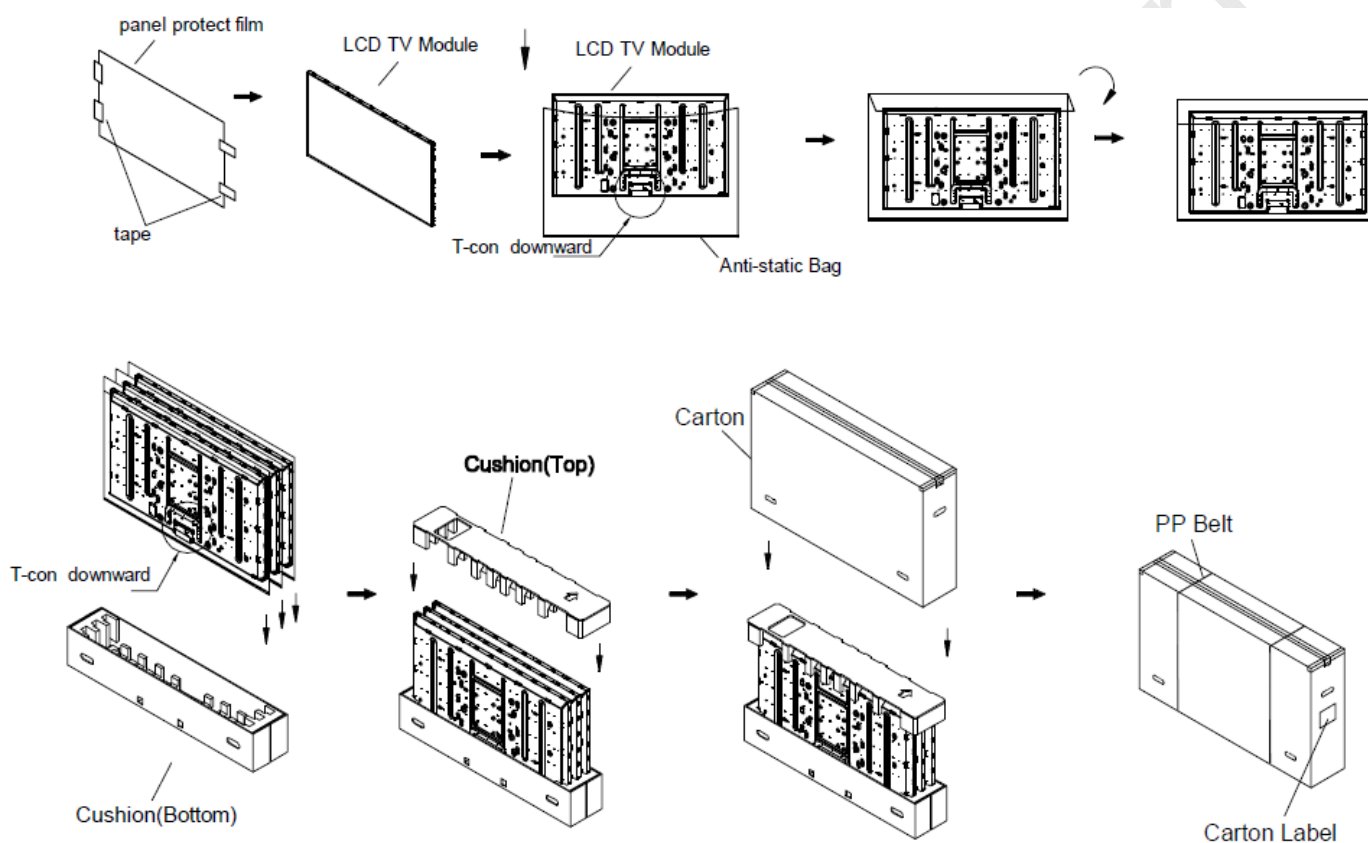

Figure 10-1

Sea / Land Transportation
(40ft & 40ft HQ Container)
Air Transportation

Figure 10-2

11. MECHANICAL CHARACTERISTIC

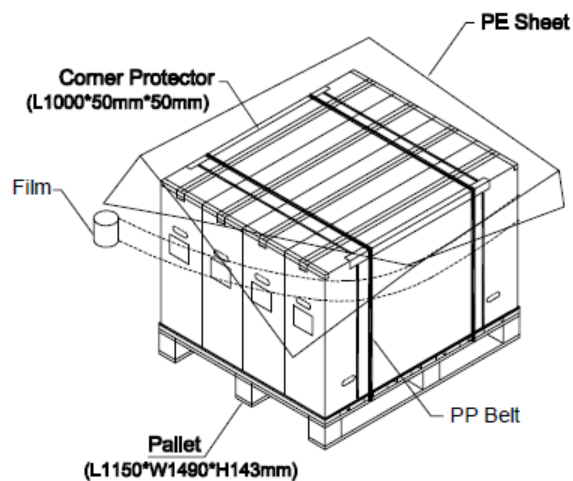
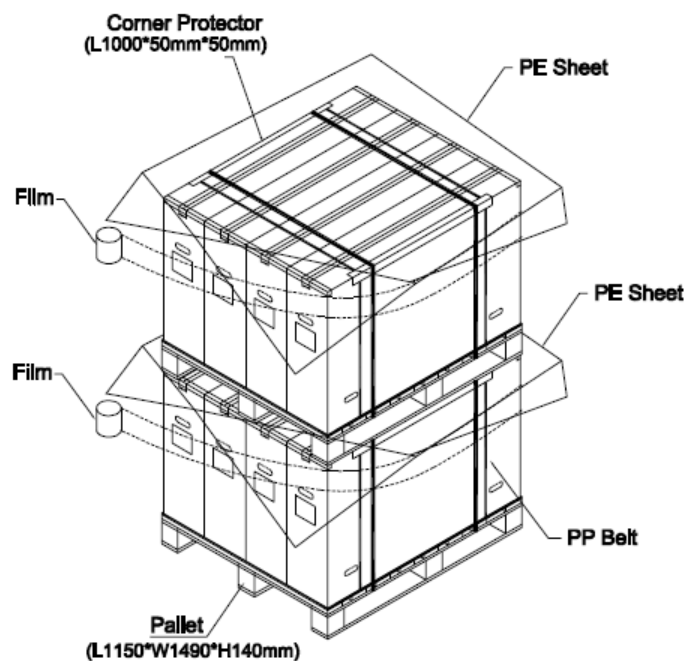