

Features

- **Ultra Low-power consumption**
 - Active: 30mA at 55ns
 - Stand-by: 5 μ A (CMOS input/output)
1 μ A CMOS input/output, L version
- **Single +2.7V to 3.3V Power Supply**
- **Equal access and cycle time**
- **55/70/85/100 ns access time**
- **Easy memory expansion with $\overline{CE1}$, CE2 and \overline{OE} inputs**
- **2.0V data retention mode**
- **TTL compatible, Tri-state input/output**
- **Automatic power-down when deselected**

Functional Description

The V62C3801024L is a low power CMOS Static RAM organized as 131,072 words by 8 bits. Easy memory expansion is provided by an active LOW $\overline{CE1}$, an active HIGH CE2, an active LOW \overline{OE} , and Tri-state I/O's. This device has an automatic power-down mode feature when deselected.

Writing to the device is accomplished by taking Chip Enable 1 ($\overline{CE1}$) with Write Enable (\overline{WE}) LOW, and Chip Enable 2 (CE2) HIGH. Reading from the device is performed by taking Chip Enable 1 ($\overline{CE1}$) with Output Enable (\overline{OE}) LOW while Write Enable (\overline{WE}) and Chip Enable 2 (CE2) is HIGH. The I/O pins are placed in a high-impedance state when the device is deselected: the outputs are disabled during a write cycle.

The V62C3801024LL comes with a 2V data retention feature and Lower Standby Power. The V62C3801024L is available in a 32-pin 8 x 20 mm TSOP1 / STSOP / 48-fpBGA packages.

Logic Block Diagram

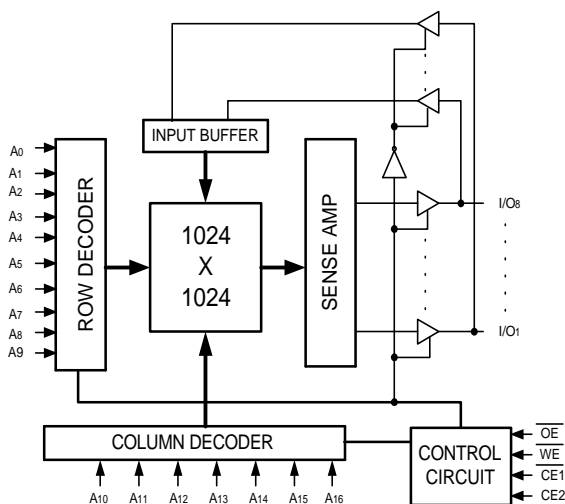

32-Pin TSOP1 / STSOP (See next page)

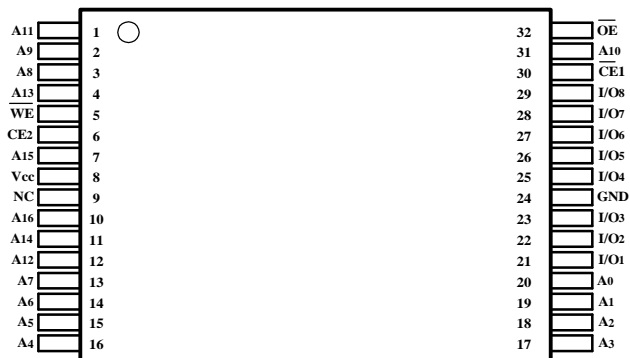

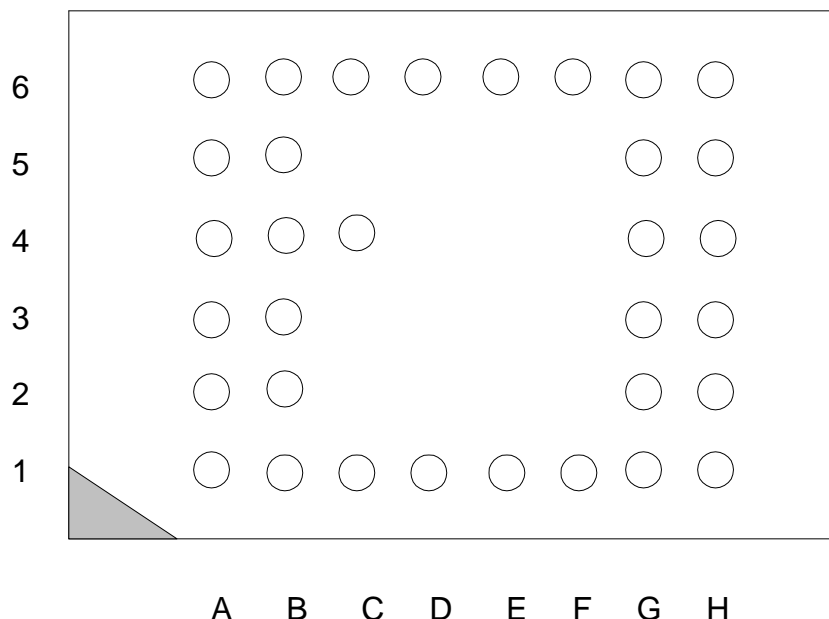
MOSEL VITELIC V62C3801024L(L)B

TOP VIEW
Top View
48-CSP Ball-Grid Array package (shading indicates no ball)

	1	2	3	4	5	6
A	A ₀	A ₁	<u>CE</u> ₂	A ₃	A ₆	A ₈
B	I/O ₄	A ₂	<u>WE</u>	A ₄	A ₇	I/O ₀
C	I/O ₅	NC	NC	A ₅	NC	I/O ₁
D	V _{SS}	NC	NC	NC	NC	V _{DD}
E	V _{DD}	NC	NC	NC	NC	V _{SS}
F	I/O ₆	<u>NC</u>	<u>NC</u>	NC	NC	I/O ₂
G	I/O ₇	<u>OE</u>	<u>CE</u> ₁	A ₁₆	A ₁₅	I/O ₃
H	A ₉	A ₁₀	A ₁₁	A ₁₂	A ₁₃	A ₁₄

Absolute Maximum Ratings *

Parameter	Symbol	Minimum	Maximum	Unit
Voltage on Any Pin Relative to Gnd	Vt	-0.5	4.6	V
Power Dissipation	P _T	–	1.0	W
Storage Temperature (Plastic)	Tstg	-55	+150	°C
Temperature Under Bias	Tbias	-40	+85	°C

* **Note:** Stresses greater than those listed above Absolute Maximum Ratings may cause permanent damage to the device. This is a stress rating only and functional operation of the device at these or any conditions outside those indicated in the operational sections of this specification is not implied. Exposure to Absolute Maximum Rating conditions for extended periods may affect reliability.

Truth Table

CE1	CE2	WE	OE	Data	Mode
H	X	X	X	High-Z	Standby
X	L	X	X	High-Z	Standby
L	H	H	L	Data Out	Active, Read
L	H	H	H	High-Z	Active, Output Disable
L	H	L	X	Data In	Active, Write

* **Key:** X = Don't Care, L = Low, H = High

Recommended Operating Conditions (T_A = 0°C to +70°C / -40°C to 85°C)**

Parameter	Symbol	Min	Typ	Max	Unit
Supply Voltage	V _{CC}	2.7	3.0	3.3	V
	Gnd	0.0	0.0	0.0	V
Input Voltage	V _{IH}	2.2	-	V _{CC} + 0.5	V
	V _{IL}	-0.5*	-	0.6	V

* V_{IL} min = -1.0V for pulse width less than t_{RC}/2.

** For Industrial Temperature

DC Operating Characteristics ($V_{CC} = 3V \pm 10\%$, $Gnd = 0V$, $T_A = 0^{\circ}C$ to $+70^{\circ}C$ / $-40^{\circ}C$ to $85^{\circ}C$)

Parameter	Sym	Test Conditions	-55		-70		-85		-100		Unit	
			Min	Max	Min	Max	Min	Max	Min	Max		
Input Leakage Current	I_{LI}	$V_{CC} = \text{Max}$, $V_{in} = \text{Gnd to } V_{CC}$	-	1	-	1	-	1	-	1	μA	
Output Leakage Current	I_{LO}	$\overline{CE1} = V_{IH}$ or $CE2 = V_{IL}$ $V_{CC} = \text{Max}$, $V_{OUT} = \text{Gnd to } V_{CC}$	-	1	-	1	-	1	-	1	μA	
Operating Power Supply Current	I_{CC}	$\overline{CE1} = V_{IL}$, $CE2 = V_{IH}$ $V_{IN} = V_{IH}$ or V_{IL} , $I_{OUT} = 0\text{mA}$	-	3	-	3	-	3	-	3	mA	
Average Operating Current	I_{CC1}	$\overline{CE1} = V_{IL}$, $CE2 = V_{IH}$ $I_{OUT} = 0\text{mA}$, Min Cycle, 100% Duty	-	30	-	25	-	20	-	15	mA	
	I_{CC2}	$\overline{CE1} = 0.2V$, $CE2 = V_{CC} - 0.2V$ $I_{OUT} = 0\text{mA}$, Cycle Time = $1\mu s$, 100% Duty	-	3	-	3	-	3	-	3	mA	
Standby Power Supply Current (TTL Level)	I_{SB}	$\overline{CE1} = V_{IH}$ or $CE2 = V_{IL}$	-	0.5	-	0.5	-	0.5	-	0.5	mA	
Standby Power Supply Current (CMOS Level)	I_{SB1}	$\overline{CE1} \geq V_{CC} - 0.2V$ or $CE2 \leq 0.2V$, $f = 0$ $V_{IN} \leq 0.2V$ or $V_{IN} \geq V_{CC} - 0.2V$	L	-	5	-	5	-	5	-	5	μA
			LL	-	1	-	1	-	1	-	1	μA
Output Low Voltage	V_{OL}	$I_{OL} = 2\text{ mA}$	-	0.4	-	0.4	-	0.4	-	0.4	V	
Output High Voltage	V_{OH}	$I_{OH} = -2\text{ mA}$	2.4	-	2.4	-	2.4	-	2.4	-	V	

Capacitance ($f = 1\text{MHz}$, $T_A = 25^{\circ}C$)

Parameter*	Symbol	Test Condition	Max	Unit
Input Capacitance	C_{in}	$V_{in} = 0V$	7	pF
I/O Capacitance	$C_{I/O}$	$V_{in} = V_{out} = 0V$	8	pF

* This parameter is guaranteed by device characterization and is not production tested.

AC Test Conditions

Input Pulse Level	0.6V to 2.2V
Input Rise and Fall Time	5ns
Input and Output Timing Reference Level	1.4V

Output Load Condition

70ns/85 ns	$C_L = 30\text{pf} + 1\text{TTL Load}$
Load 100ns/120 ns	$C_L = 100\text{pf} + 1\text{TTL Load}$

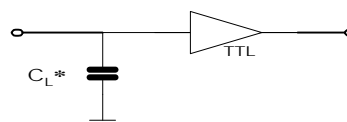

Figure A. * Including Scope and Jig Capacitance

Read Cycle ^(3,9) ($V_{cc} = 3.0V \pm 0.3V$, Gnd = 0V, $T_A = 0^{\circ}C$ to $+70^{\circ}C$ / $-40^{\circ}C$ to $+85^{\circ}C$)

Parameter	Symbol	-55		-70		-85		-100		Unit	Note
		Min	Max	Min	Max	Min	Max	Min	Max		
Read Cycle Time	t_{RC}	55	-	70	-	85	-	100	-	ns	
Address Access Time	t_{AA}	-	55	-	70	-	85	-	100	ns	
Chip Enable Access Time	t_{ACE}	-	55	-	70	-	85	-	100	ns	
Output Enable Access Time	t_{OE}	-	35	-	40	-	40	-	50	ns	
Output Hold from Address Change	t_{OH}	10	-	10	-	10	-	10	-	ns	
Chip Enable to Output in Low-Z	t_{CLZ}	10	-	10	-	10	-	10	-	ns	4,5
Chip Disable to Output in High-Z	t_{CHZ}	-	25	-	30	-	35	-	40	ns	4,5
Output Enable to Output in Low-Z	t_{OLZ}	5	-	5	-	5	-	5	-	ns	4,5
Output Disable to Output in High-Z	t_{OHZ}	-	25	-	25	-	30	-	35	ns	4,5
Power-Up Time	t_{PU}	0	-	0	-	0	-	0	-	ns	5
Power-Down Time	t_{PD}	-	55	-	70	-	85	-	100	ns	5

Write Cycle ^(3,11) ($V_{cc} = 3.0V \pm 0.3V$, Gnd = 0V, $T_A = 0^{\circ}C$ to $+70^{\circ}C$ / $-40^{\circ}C$ to $+85^{\circ}C$)

Parameter	Symbol	-55		-70		-85		-100		Unit	Note
		Min	Max	Min	Max	Min	Max	Min	Max		
Write Cycle Time	t_{WC}	55	-	70	-	85	-	100	-	ns	
Chip Enable to Write End	t_{CW}	45	-	60	-	70	-	80	-	ns	
Address Setup to Write End	t_{AW}	45	-	60	-	70	-	80	-	ns	
Address Setup Time	t_{AS}	0	-	0	-	0	-	0	-	ns	
Write Pulse Width	t_{WP}	45	-	50	-	60	-	70	-	ns	
Write Recovering Time	t_{WR}	0	-	0	-	0	-	0	-	ns	
Data Valid to Write End	t_{DW}	25	-	30	-	35	-	40	-	ns	
Data Hold Time	t_{DH}	0	-	0	-	0	-	0	-	ns	
Write Enable to Output in High-Z	t_{WZ}	-	25	-	30	-	35	-	40	ns	4,5
Output Active from Write End	t_{OW}	5	-	5	-	5	-	5	-	ns	4,5

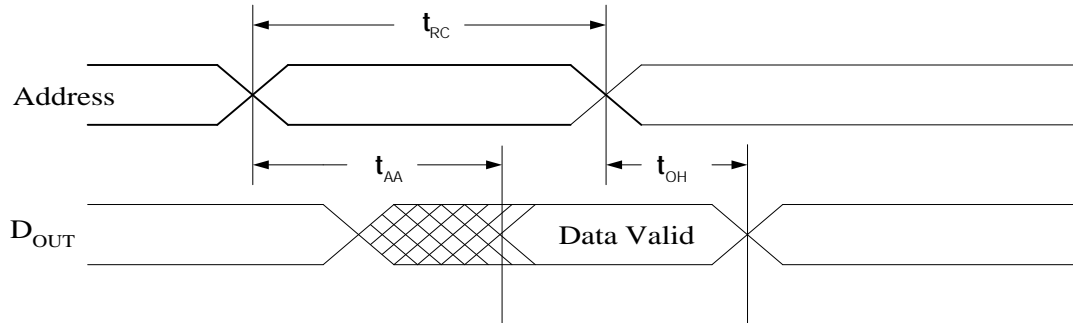
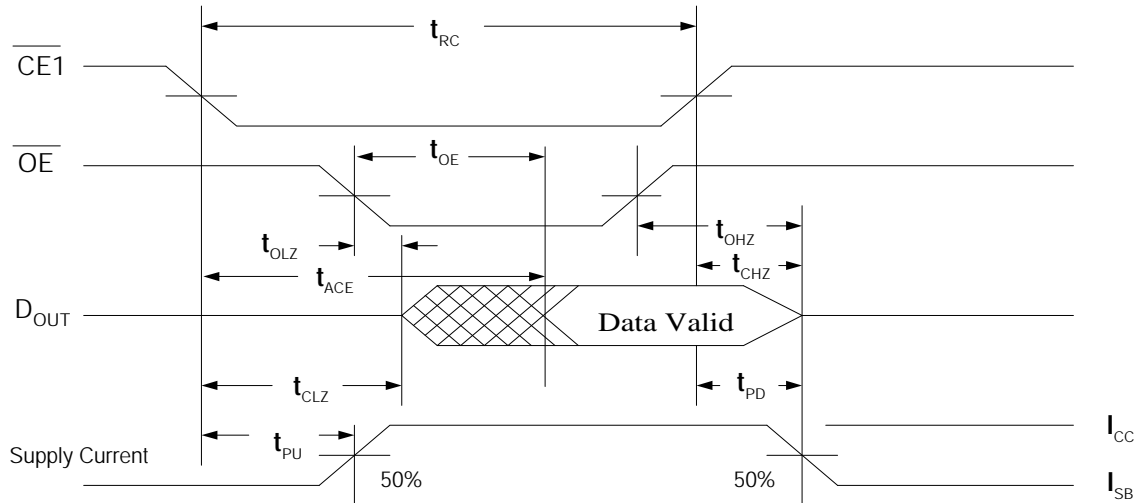
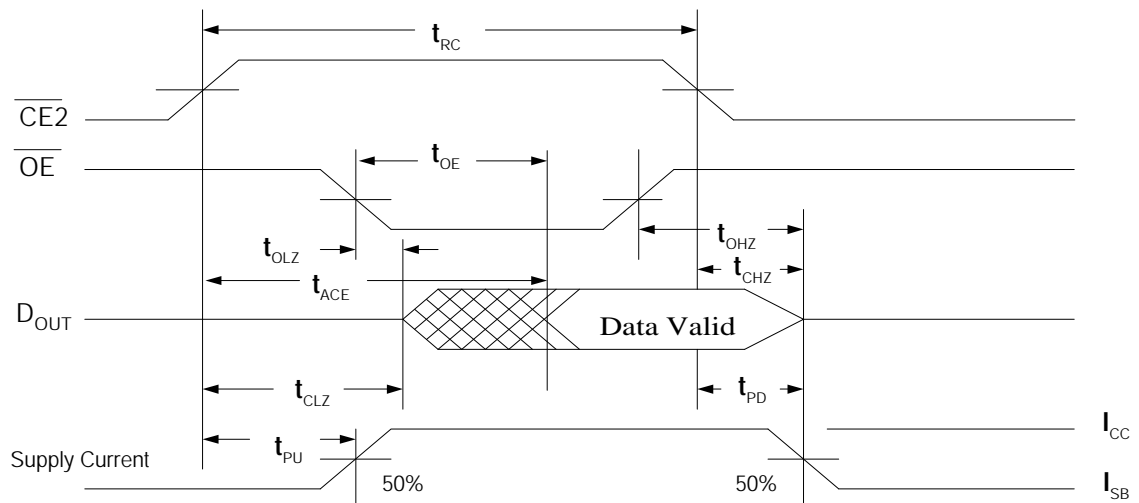
Timing Waveform of Read Cycle 1^(3,6,7,9) (Address Controlled)

Timing Waveform of Read Cycle 2^(5,6,8,9) ($\overline{CE1}$ Controlled)

Timing Waveform of Read Cycle 3^(3,6,8,9) ($CE2$ Controlled)

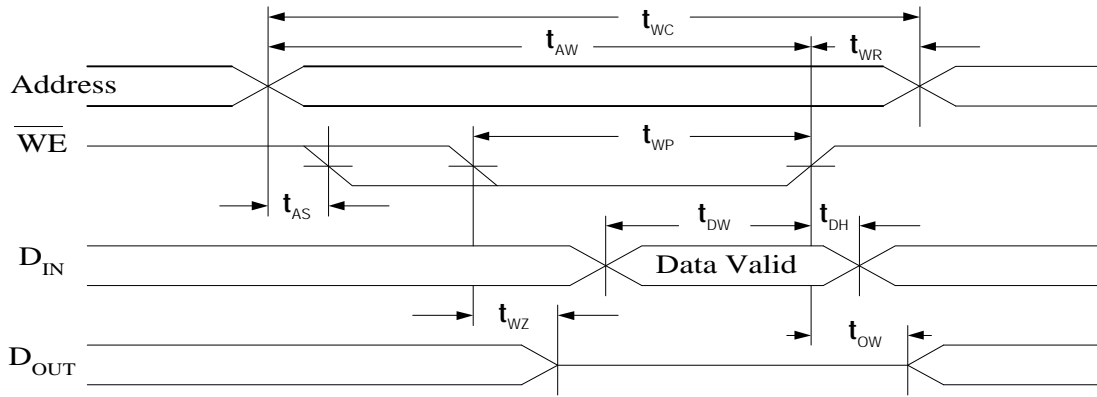

Timing Waveform of Write Cycle 1 ^(10,11) (\overline{WE} Controlled)

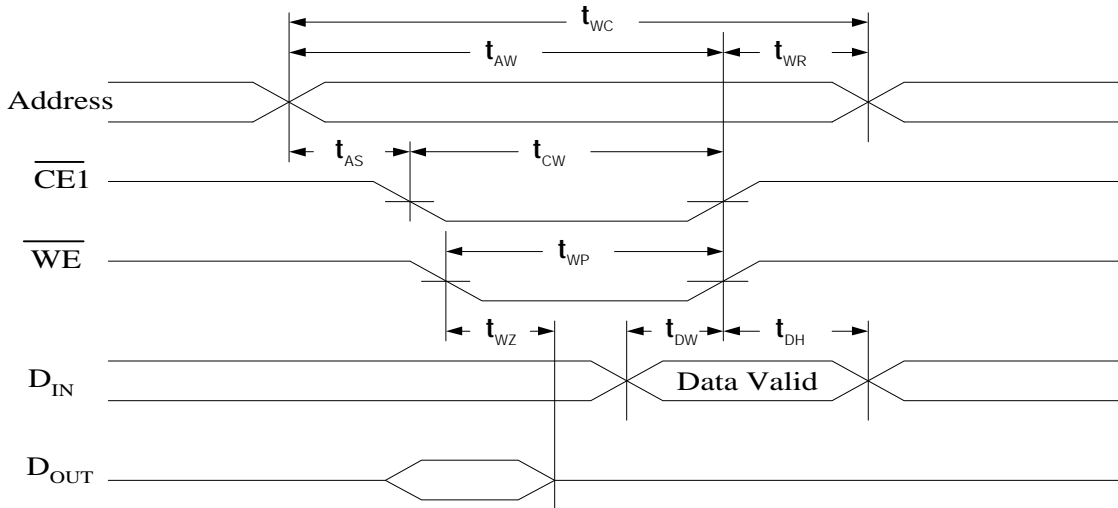

Timing Waveform of Write Cycle 2 ^(10,11) ($\overline{CE1}$ Controlled)



Timing Waveform of Write Cycle 3 ^(10,11) ($\overline{CE2}$ Controlled)

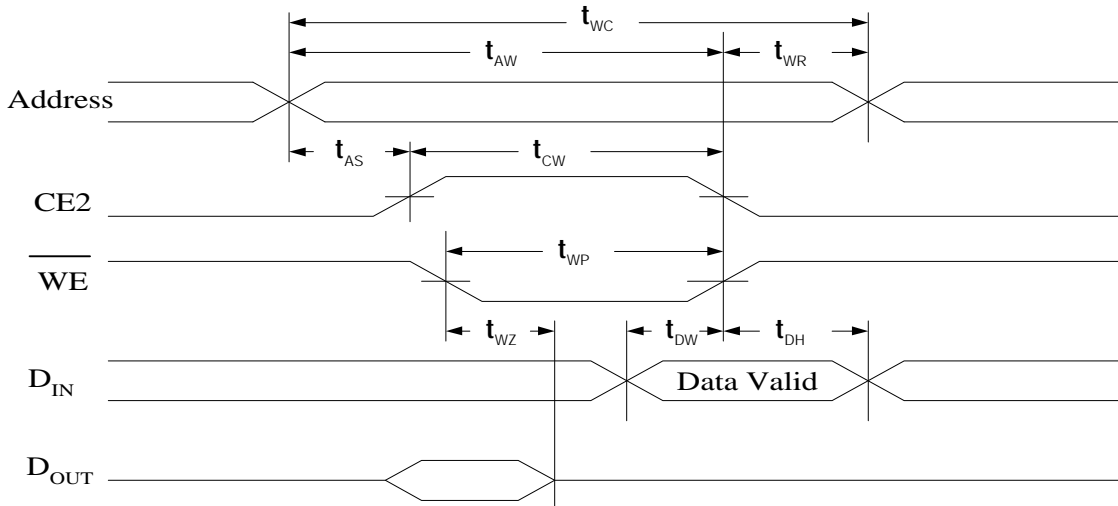

Data Retention Characteristics (L Version Only)⁽¹⁾

Parameter	Symbol	Test Condition	Min	Max	Unit
V _{CC} for Data Retention	V _{DR}	$\overline{CE}_1 \geq V_{CC} - 0.2V$ or	1.0	-	V
Data Retention Current	I _{CCDR}	$CE_2 \leq +0.2V$	-	5	μA
Chip Deselect to Data Retention Time	t _{CDR}	$V_{IN} \geq V_{CC} - 0.2V$ or	0	-	ns
Operation Recovery Time ⁽²⁾	t _R	$V_{IN} \leq 0.2V$	t _{RC}	-	ns

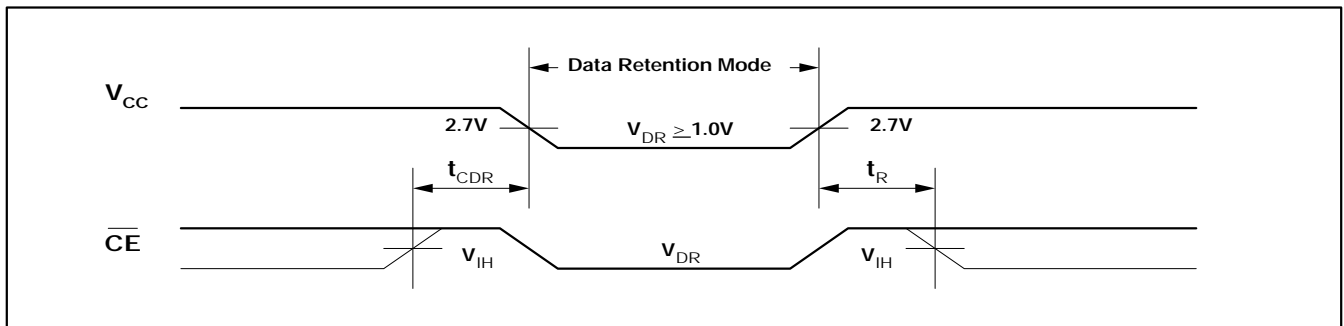
Data Retention Waveform (L Version Only) (T_A = 0⁰C to +70⁰C / -40⁰C to +85⁰C)

Notes

1. L-version includes this feature.
2. This Parameter is sampled and not 100% tested.
3. For test conditions, see *AC Test Condition*, Figure A.
4. This parameter is tested with CL = 5pF as shown in Figure B. Transition is measured ± 500mV from steady-state voltage.
5. This parameter is guaranteed, but is not tested.
6. \overline{WE} is HIGH for read cycle.
7. \overline{CE}_1 and \overline{OE} are LOW and CE2 is HIGH for read cycle.
8. Address valid prior to or coincident with \overline{CE}_1 transition LOW or CE2 transition HIGH.
9. All read cycle timings are referenced from the last valid address to the first transition address.
10. \overline{CE}_1 or \overline{WE} must be HIGH or CE2 must be LOW during address transition.
11. All write cycle timings are referenced from the last valid address to the first transition address.

Ordering Information

Device Type*	Speed	Package
V62C3801024L-55T	55 ns	8 x 20 mm 32-pin Plastic TSOP1
V62C3801024L-70T	70 ns	
V62C3801024L-85T	85 ns	
V62C3801024L-100T	100 ns	
V62C3801024LL-55T	55 ns	
V62C3801024LL-70T	70 ns	
V62C3801024LL-85T	85 ns	
V62C3801024LL-100T	100 ns	
V62C3801024L-55V	55 ns	8 x 13.4 mm 32-pin Plastic STSOP
V62C3801024L-70V	70 ns	
V62C3801024L-85V	85 ns	
V62C3801024L-100V	100 ns	
V62C3801024LL-55V	55 ns	
V62C3801024LL-70V	70 ns	
V62C3801024LL-85V	85 ns	
V62C3801024LL-100V	100 ns	
V62C3801024L(L)-55B	55 ns	48-fpBGA
V62C3801024L(L)-70B	70 ns	
V62C3801024L(L)-85B	85 ns	
V62C3801024L(L)-100B	100 ns	

* For Industrial Temperature tested devices, an “I” designator will be added to the end of the device number.

U.S.A.

3910 NORTH FIRST STREET
SAN JOSE, CA 95134
PHONE: 408-433-6000
FAX: 408-433-0952

TAIWAN

7F, NO. 102
MIN-CHUAN E. ROAD, SEC. 3
TAIPEI
PHONE: 886-2-2545-1213
FAX: 886-2-2545-1209

SINGAPORE

10 ANSON ROAD #23-13
INTERNATIONAL PLAZA
SINGAPORE 079903
PHONE: 65-3231801
FAX: 65-3237013

UK & IRELAND

SUITE 50, GROVEWOOD
BUSINESS CENTRE
STRATHCLYDE BUSINESS
PARK
BELLSHILL, LANARKSHIRE,
SCOTLAND, ML4 3NQ
PHONE: 44-1698-748515
FAX: 44-1698-748516

NO 19 LI HSIN ROAD
SCIENCE BASED IND. PARK
HSIN CHU, TAIWAN, R.O.C.
PHONE: 886-3-579-5888
FAX: 886-3-566-5888

JAPAN

ONZE 1852 BUILDING 6F
2-14-6 SHINTOMI, CHUO-KU
TOKYO 104-0041
PHONE: 03-3537-1400
FAX: 03-3537-1402

**GERMANY
(CONTINENTAL
EUROPE & ISRAEL)**

BENZSTRASSE 32
71083 HERRENBERG
GERMANY
PHONE: +49 7032 2796-0
FAX: +49 7032 2796 22

U.S. SALES OFFICES**NORTHWESTERN**

3910 NORTH FIRST STREET
SAN JOSE, CA 95134
PHONE: 408-433-6000
FAX: 408-433-0952

SOUTHWESTERN

302 N. EL CAMINO REAL #200
SAN CLEMENTE, CA 92672
PHONE: 949-361-7873
FAX: 949-361-7807

**CENTRAL,
NORTHEASTERN &
SOUTHEASTERN**

604 FIELDWOOD CIRCLE
RICHARDSON, TX 75081
PHONE: 214-826-6176
FAX: 214-828-9754

The information in this document is subject to change without notice.

MOSEL VITELIC makes no commitment to update or keep current the information contained in this document. No part of this document may be copied or reproduced in any form or by any means without the prior written consent of MOSEL-VITELIC.

MOSEL VITELIC subjects its products to normal quality control sampling techniques which are intended to provide an assurance of high quality products suitable for usual commercial applications. MOSEL VITELIC does not do testing appropriate to provide 100% product quality assurance and does not assume any liability for consequential or incidental arising from any use of its products. If such products are to be used in applications in which personal injury might occur from failure, purchaser must do its own quality assurance testing appropriate to such applications.