



Ultra Low Power 3-Pin Voltage Surveillance with Time-out

Features

- Clear microprocessor restart after power up
- Processor reset at power down
- Reset output guaranteed down to $V_{DD} = 1\text{ V}$
- Low power consumption: typ. 3 mA at $V_{DD} = 5\text{ V}$
- - 40 to +85 °C temperature range
- On request extended temperature range, -40 to +125 °C
- On-chip oscillator
- No external components required
- Push-pull or Open drain output
- TO-92, SOT-23 5L packages
- Pin compatible with DS 1233 A in TO-92

Description

The V6301 is a CMOS device which monitors the supply voltage of any electronic system, and generates the appropriate Reset signal. The threshold defines the minimum allowed voltage which guarantees the good functionality of the system. As long as V_{DD} stays upside this voltage level, the output stays inactive. If V_{DD} drops below V_{TH} , the output gets active. When V_{DD} rises above V_{TH} , the output remains active for an additional 290 ms (typ.). This allows the system to stabilize before getting fully active. The threshold voltage may be obtained in different versions: 2.0 V, 2.4 V, 2.8 V, 3.5 V, 4.0 V, 4.5 V.

Applications

All microprocessor applications where an automatic restart is required:

- Computer electronics
- White / Brown goods
- Automotive electronics
- Industrial electronics
- Telecom systems
- Hand-held systems

Typical Operating Configuration

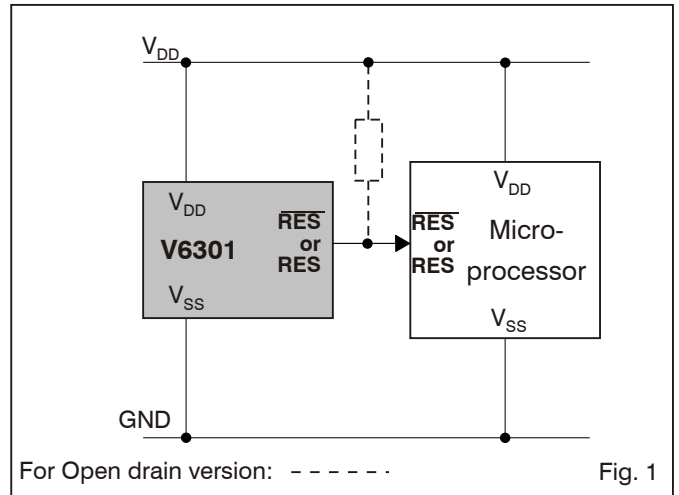

Pin Assignment

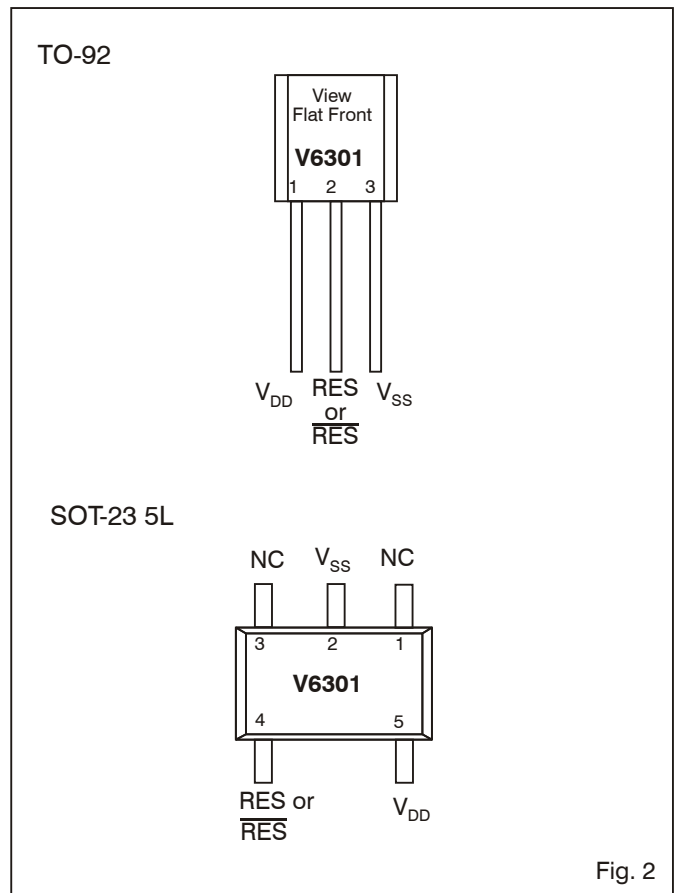



Absolute Maximum Ratings

Parameter	Symbol	Conditions
Voltage at V_{DD} to V_{SS}	V_{DD}	-0.3V to +10 V
Min. voltage at RES or \overline{RES}	V_{min}	$V_{SS} - 0.3 V$
Max. voltage at RES or \overline{RES}	V_{max}	$V_{DD} + 0.3 V$
Storage temperature range	T_{STO}	-65° to +150 °C

Table 1

Stresses above these listed maximum ratings may cause permanent damage to the device. Exposure beyond specified operating conditions may affect device reliability or cause malfunction.

Handling Procedures

This device has built-in protection against high static voltages or electric fields; however, anti-static precautions must be taken as for any other CMOS component. Unless otherwise specified, proper operation can only occur when all terminal voltages are kept within the supply voltage range.

Operating Conditions

Parameter	Symbol	Min.	Typ.	Max.	Units
Operating temperature ¹⁾	T_A	-40		+125	°C
Positive supply voltage	V_{DD}	1		8	V

Table 2

¹⁾The maximum operating temperature is confirmed by sampling at initial device qualification.

Electrical Characteristics

$T_A = -40$ to $+85$ °C, unless otherwise specified

Parameter	Symbol	Test Conditions	Min.	Min. at 25 °C	Typ.	Max. at 25 °C	Max.	Units
Supply current ¹⁾	I_{DD}	$V_{DD} = 2 V$			1.5	2.1	3.1	mA
	I_{DD}	$V_{DD} = 5 V$			3.0	3.9	5.7	mA
	I_{DD}	$V_{DD} = 8 V$			5.2	6.8	10.0	mA
Threshold voltage	V_{TH}	Version: A,G,M	1.77	1.84	1.95	2.04	2.17	V
	V_{TH}	Version: B,H,N	2.09	2.18	2.32	2.41	2.55	V
	V_{TH}	Version: C,I,O	2.48	2.59	2.73	2.86	3.03	V
	V_{TH}	Version: D,J,P	3.11	3.23	3.42	3.59	3.80	V
	V_{TH}	Version: E,K,Q	3.55	3.70	3.88	4.08	4.32	V
	V_{TH}	Version: F,L,R	4.05	4.22	4.42	4.67	4.95	V
Threshold hysteresis	V_{HYS}				25			mV
RES Output Low Level	V_{OL}	$V_{DD} = 5 V, I_{OL} = 8 mA$			175		400	mV
	V_{OL}	$V_{DD} = 3 V, I_{OL} = 4 mA$			140		300	mV
	V_{OL}	$V_{DD} = 1 V, I_{OL} = 50 mA$			20		90	mV
RES Output High Level	V_{OH}	$V_{DD} = 5 V, I_{OH} = -8 mA$	4.3		4.5			V
	V_{OH}	$V_{DD} = 3 V, I_{OH} = -4 mA$	2.3		2.6			V
	V_{OH}	$V_{DD} = 1 V, I_{OH} = -100 mA$	850		950			mV
Output leakage current ²⁾	I_{LEAK}	$V_{DD} = 8 V$			0.05		1	mA

Table 3

¹⁾ RES or \overline{RES} open

²⁾ Only for Open drain versions

Timing Characteristics

$V_{DD} = 5.0 V, T_A = -40$ to $+85$ °C, unless otherwise specified

Parameter	Symbol	Test Conditions	Min.	Typ.	Max.	Units
Power on reset time	t_{POR}		140	290	560	ms
Sensitivity ³⁾	t_{SEN}	for $V_{DD} = 5 V$ to $3 V$ in 5 ms	20	$0.8 t_R$		ms
Reaction time ³⁾	t_R	for $V_{DD} = 5 V$ to $3 V$ in 5 ms	22	75	150	ms

³⁾ Tested on versions with V_{TH} higher than 3 V

Table 4



Timing Waveforms

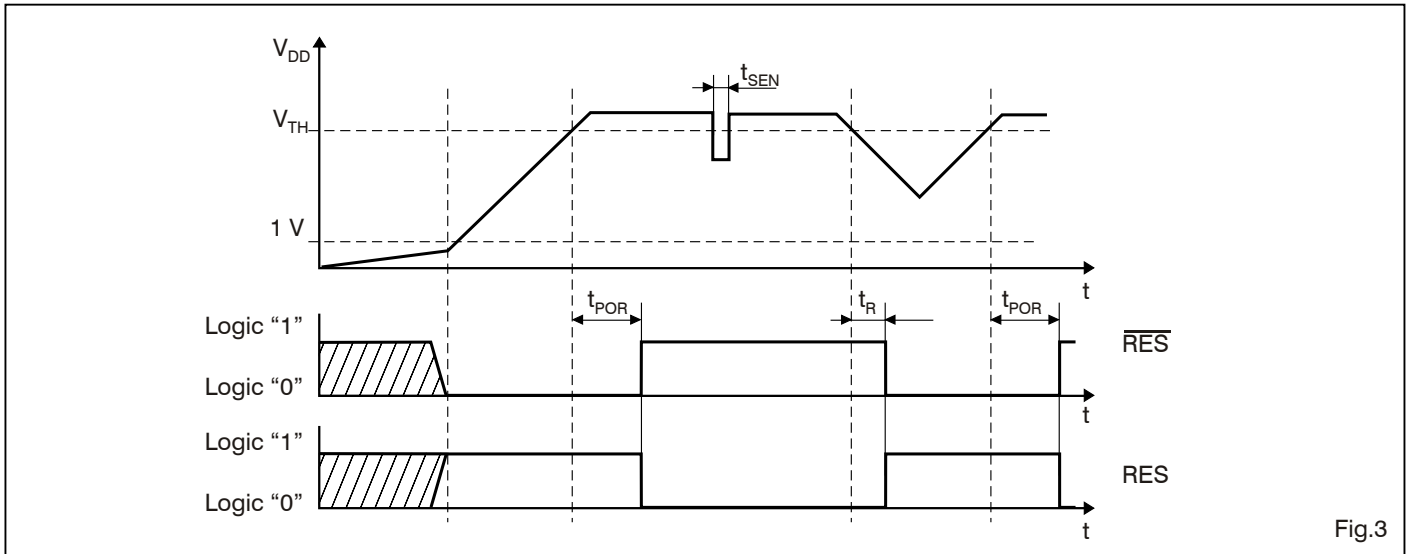

Block Diagram

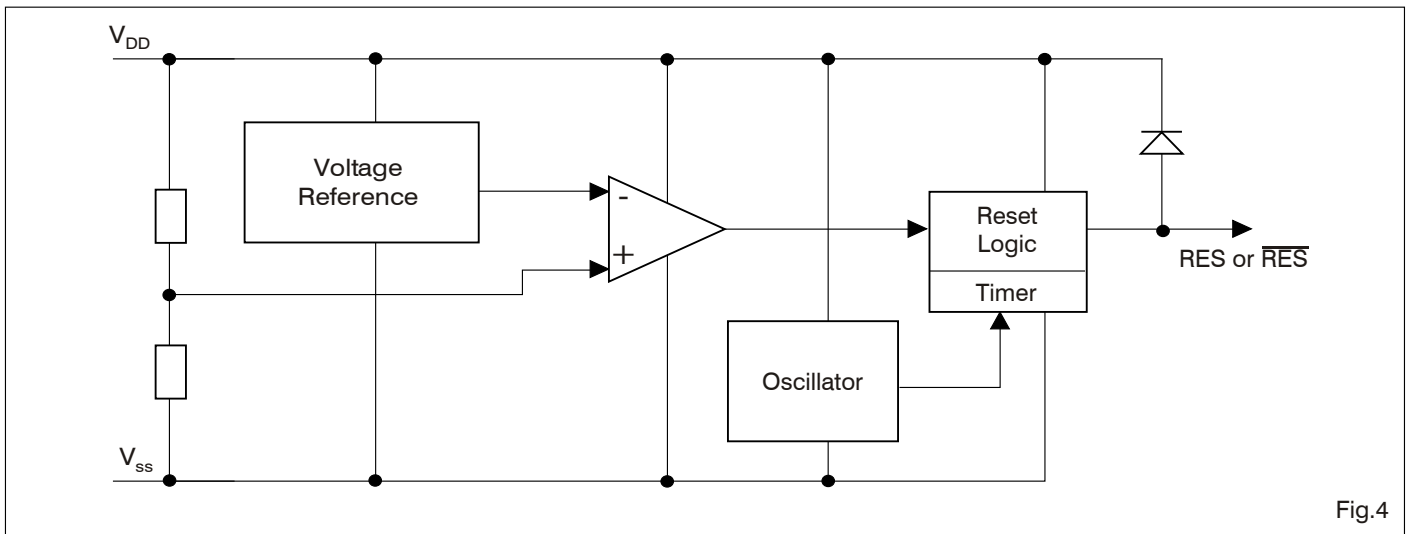

Pin Description

TO-92

Pin	Name	Function
1	V_{DD}	Positive Supply
2	RES or \overline{RES}	Reset output
3	V_{SS}	Supply ground

Table 5

SOT-23 5L

Pin	Name	Function
1	NC	No connection
2	V_{SS}	Supply ground
3	NC	No connection
4	RES or \overline{RES}	Reset output
5	V_{DD}	Positive supply

Table 6



Ordering Information

The V6301 is available with Push-pull or Open output stage and Reset active low or high.

Ordering form: V6301 <version letter> < packaging >

Example: Smart reset with: - Reset active low

- Open drain output
- 2.8 V threshold
- TO-92 package

V6301 O TO-92

When ordering, please specify the complete part number.

Version letter definition

Output stage	Threshold Voltage [V]					
	2.0	2.4	2.8	3.5	4.0	4.5
Push-pull, Reset active low	A	B ¹⁾	C	D	E	F
Push-pull, Reset active high	G ¹⁾	H	I	J	K ¹⁾	L
Open drain, Reset active low	M ¹⁾	N ¹⁾	O	P	Q ¹⁾	R

Table 7

Chip form and SOT-223 on request

¹⁾ Non-stock items, minimum order 30 K pieces.