

NTSC/PAL Encoder

T-77-29

Description

The V7040 is an IC that can operate in both NTSC and PAL modes. It superimposes analog RGB signals and outputs them as such, or as composite video signals. Both types of output can drive the 75Ω load directly.

Features

- 5 V single supply operation
- Low power consumption (135 mW)
- Built-in 75Ω driver (RGB output, 2 systems of composite video output)
- Compatible with both NTSC and PAL modes
- Superimposition (MIX, half-tone functions)

Functions

- SW circuit for superimposition
- MTX circuit
- R-Y, B-Y MOD circuit
- 75Ω driver for RGB and composite video outputs

Structure

Bipolar silicon monolithic IC

Absolute Maximum Ratings

• Supply voltage	V _{cc}	10	V
• Operating temperature	T _{opr}	-20 to +75	°C
• Storage temperature	T _{stg}	-55 to +150	°C
• Allowable power dissipation	P _o	1250	mW

Recommended Operating Condition

• Supply voltage	V _{cc}	5 ± 0.25	V
------------------	-----------------	----------	---

Package Outline

Unit: mm

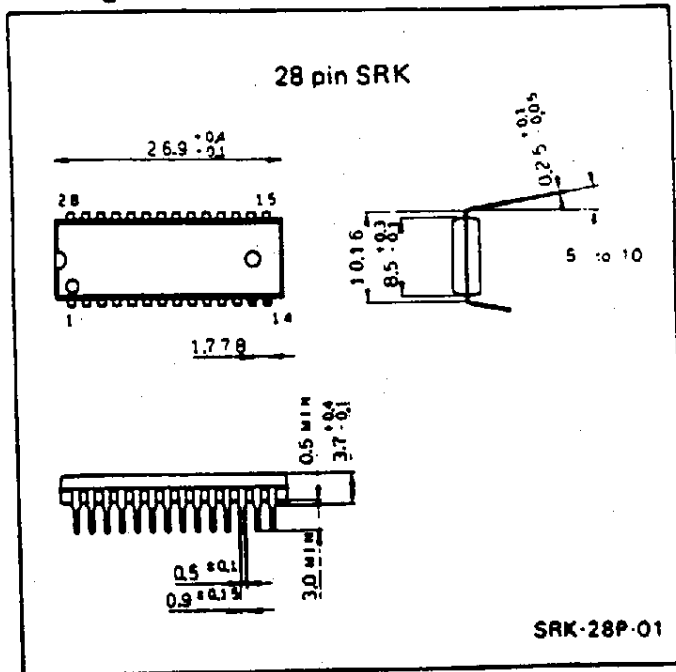

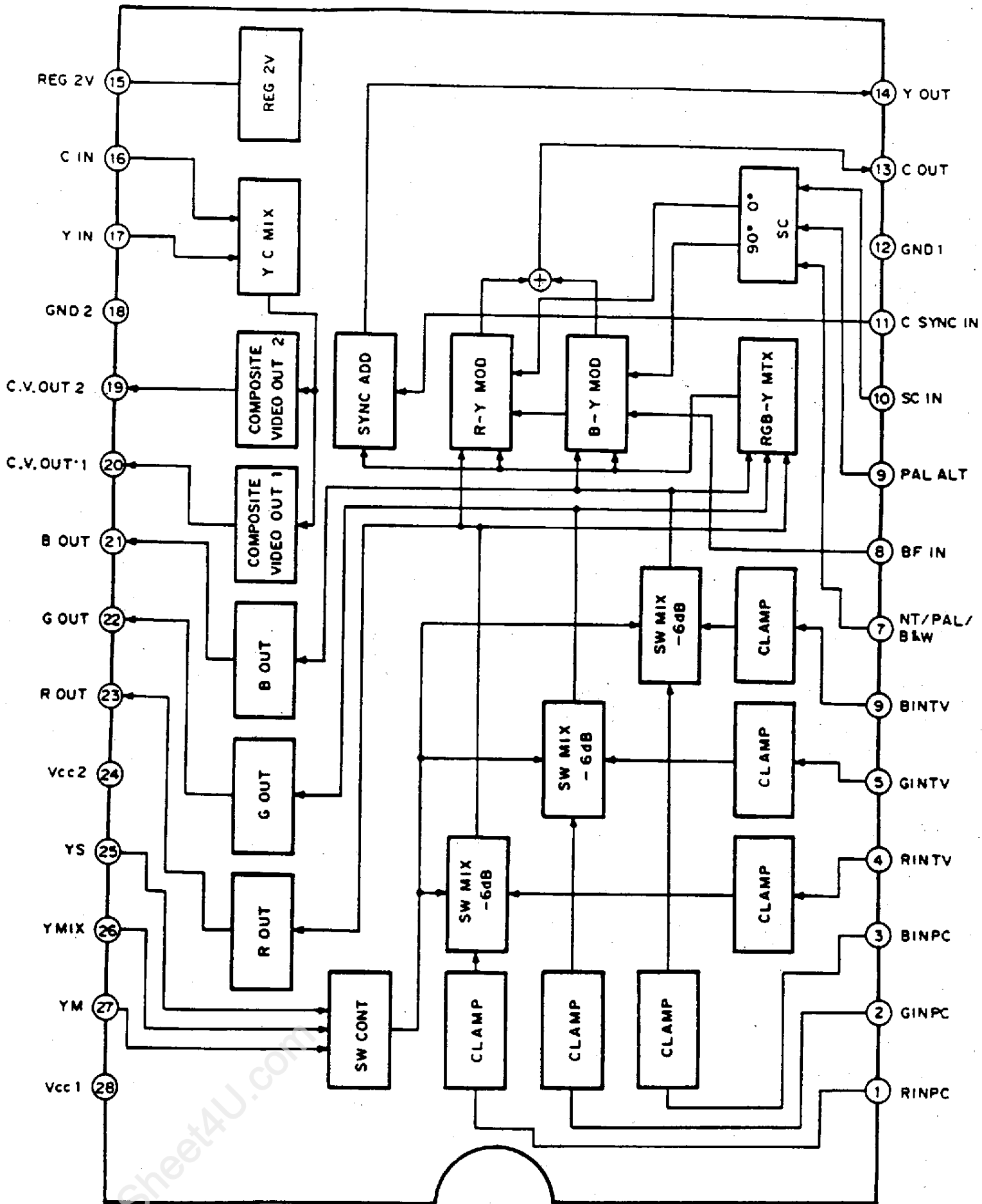

Pin Description

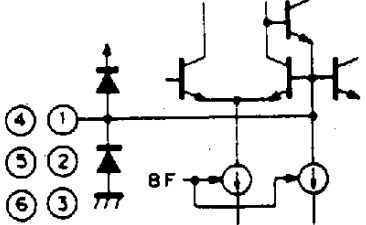
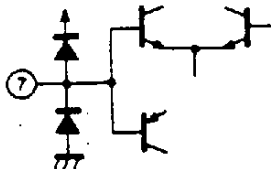
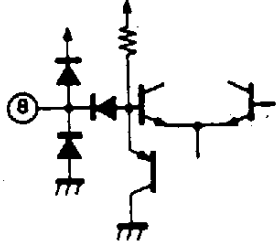
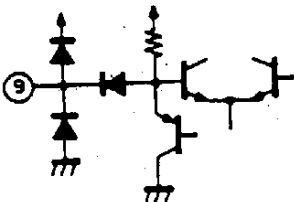
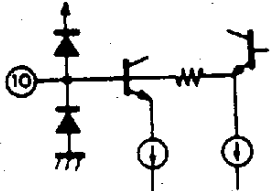
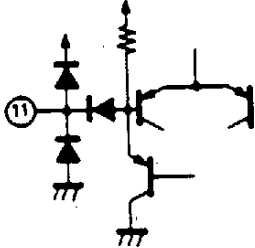
No.	Symbol	Equivalent circuit	Description
1 2 3 4 5 6	RINPC GINPC BINPC RINTV GINTV BINTV		Inputs an RGB color signal from a PC or a TV. Input must be of sufficiently low impedance to clamp.
7	NT/PAL B&W		Switches the modes of NTSC, PAL, and B&W. 4.0 V to V _{CC} NTSC mode 2.0 V to 3.0 V PAL mode 0 V to 0.8 V B&W mode
8	BF IN		Inputs burst flag signal. Clamp is performed by this burst flag signal. L: 0 V to 0.8 V H: 2.0 V to V _{CC} Burst at L.
9	PAL ALT		Inputs the PAL ALT signal and inverts the burst and chroma signal phases in every field in PAL mode. 0 V to 0.8 V Burst at 225° 2.0 V to V _{CC} Burst at 135°
10	SC IN		Inputs the sub-carrier. Input sine wave between 0.4 to 0.8 V _{p-p} .
11	C SYNC IN		Inputs composite SYNC signal. L: 0 V to 0.8 V H: 2.0 V to V _{CC} SYNC at L

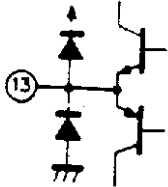
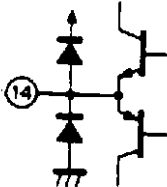
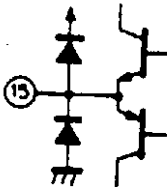
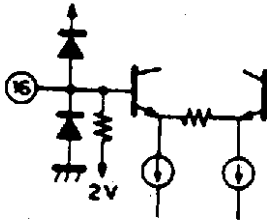
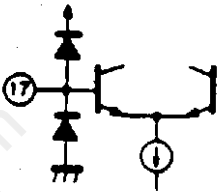
No.	Symbol	Equivalent circuit	Description
12	GND1		Ground pin for circuits other than RGB OUT and C.V.OUT circuits. Connect with GND2 of pin 18 at the lowest impedance.
13	C OUT		Outputs chroma signal to BPF.
14	Y OUT		Outputs Y signal to delay line.
15	REG2V		For the inner reference voltage. Ground at 10 μ F.
16	C IN		Inputs the chroma signal from which the harmonics are removed by BPF.
17	Y IN		Inputs Y signal which is delayed by delay line.

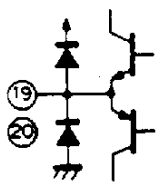
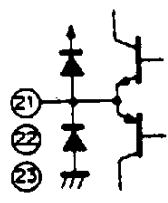
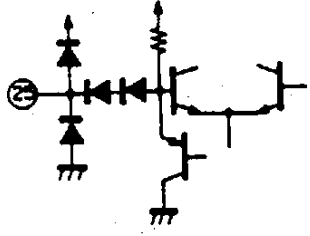
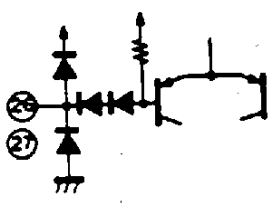
No.	Symbol	Equivalent circuit	Description																																				
18	GND2		Ground pin for RGB OUT circuit and for C.V OUT circuit. Connect with GND1 of pin 12 at the lowest impedance.																																				
19 20	C.V.OUT2 C.V.OUT1		Outputs a composite video signal encoded from switched RGB signals. The load of 75 Ω can be directly driven.																																				
21 22 23	B OUT G OUT R OUT		Outputs a switched RGB signal as an RGB signal. The load of 75 Ω can be directly driven.																																				
24	Vcc2		Power source for RGB OUT circuit and for C.V.OUT circuit. Decoupling should be performed with a very large capacity.																																				
25	YS		Switches TV, PC, MIX and halftone modes. Input at TTL level.																																				
26 27	YMIX YM		<p>SW mode</p> <table border="1"> <thead> <tr> <th>YS</th> <th>YMIX</th> <th>YM</th> <th>SW mode</th> </tr> </thead> <tbody> <tr> <td>0</td> <td>0</td> <td>0</td> <td>TV</td> </tr> <tr> <td>0</td> <td>0</td> <td>1</td> <td>Half-tone</td> </tr> <tr> <td>0</td> <td>1</td> <td>0</td> <td>TV</td> </tr> <tr> <td>0</td> <td>1</td> <td>1</td> <td>Half-tone</td> </tr> <tr> <td>1</td> <td>0</td> <td>0</td> <td>PC</td> </tr> <tr> <td>1</td> <td>0</td> <td>1</td> <td>PC</td> </tr> <tr> <td>1</td> <td>1</td> <td>0</td> <td>MIX</td> </tr> <tr> <td>1</td> <td>1</td> <td>1</td> <td>MIX</td> </tr> </tbody> </table>	YS	YMIX	YM	SW mode	0	0	0	TV	0	0	1	Half-tone	0	1	0	TV	0	1	1	Half-tone	1	0	0	PC	1	0	1	PC	1	1	0	MIX	1	1	1	MIX
YS	YMIX	YM	SW mode																																				
0	0	0	TV																																				
0	0	1	Half-tone																																				
0	1	0	TV																																				
0	1	1	Half-tone																																				
1	0	0	PC																																				
1	0	1	PC																																				
1	1	0	MIX																																				
1	1	1	MIX																																				
28	Vcc1		Power source for circuits other than RGB OUT and C.V.OUT.																																				

(Vcc=5V Ta=25° See the Electrical Characteristic Test Circuit)

Item	Symbol	Condition	Test point	Min.	Typ.	Max.	Unit
Supply current 1	I _{CC1}	SG1 to SG6 AC 0V	NTSC mode	I ₁	7.0	12.2	17.3
Supply current 2	I _{CC2}	SG12 to SG14 DC 0.8V					
BW mode supply current 1	I _{EW}	SG7-SG9 DC 2V	BW mode	I ₁	4.3	8.1	11.9
R output level	V _R	Fig. 1 RINTV = 1 V _{P.P.} , f = 200 kHz	C	0.63	0.71	0.80	V _{P.P.}
G output level	V _G	Fig. 1 GINTV = 1 V _{P.P.} , f = 200 kHz	D	0.63	0.71	0.80	V _{P.P.}
B output level	V _B	Fig. 1 BINTV = 1 V _{P.P.} , f = 200 kHz	E	0.63	0.71	0.80	V _{P.P.}
RGB frequency characteristic	f _{CRGB}	Fig. 1 RGBINTV = 1 V _{P.P.} , f = 10 MHz	CDE	-3			B
RGB crosstalk	CT	Fig. 1 V _{IN} = 1 V _{P.P.} , f = 200 kHz	CDE			-40	dB
SW delay time	T _d	Fig. 2 S1 to S6 On	CDE		40	80	ns
Half-tone level	G _{HT}	Fig. 3 20 log (VM/V)	CDE	-8	-6	-4	dB
MIX level	G _{MIX}	Fig. 3 20 log (VMIX/V)	CDE	-8	-6	-4	dB
Sync level	V _{SYNC}	Fig. 4 Sync level	AB	0.24	0.29	0.34	V
Y level at R 100%	V _{YR}	Fig. 4 Y level at R = 1 V	BW mode	AB	0.18	0.21	0.25
Y level at G 100%	V _{YG}	Fig. 4 Y level at G = 1 V					
Y level at B 100%	V _{YB}	Fig. 4 Y level at B = 1 V					
Y level at RGB 100%	V _{YW}	Fig. 4 Y level at RGB = 1 V					
DG	DG	Fig. 5 S7, S8 On	AB			8	%
DP	DP	Fig. 5 S7, S8 On	AB			4	deg
R chroma level	V _{CR}	Fig. 6 R chroma level	NTSC mode	AB	2.53	3.16	3.79
R chroma phase	θ _R	Fig. 6 R phase					
G chroma level	V _{CG}	Fig. 6 G chroma level					
G chroma phase	θ _G	Fig. 6 G phase					
B chroma level	V _{CB}	Fig. 6 B chroma level					
B chroma phase	θ _B	Fig. 6 B phase					
NTSC burst level	V _{BNT}	Fig. 6 Burst level					
PAL burst	V _{BPAL}	Fig. 6 Burst level	PAL mode	AB	0.80	1.00	1.20
PAL burst phase	θ _{BPAL}	Fig. 6 Burst phase PAL mode	PALALT = 2.0 V	AB	123	135	147
			PALALT = 0.8 V		213	225	237
Carrier leak	V _{LSC}	Fig. 6 Leak at pedestal	AB			40	mV
Leak at B&W mode	V _{LW}	Fig. 4 Leak of chroma	AB			30	mV

* All phase reference should be the burst of NTSC = 180°

Electrical Characteristics Test Circuit

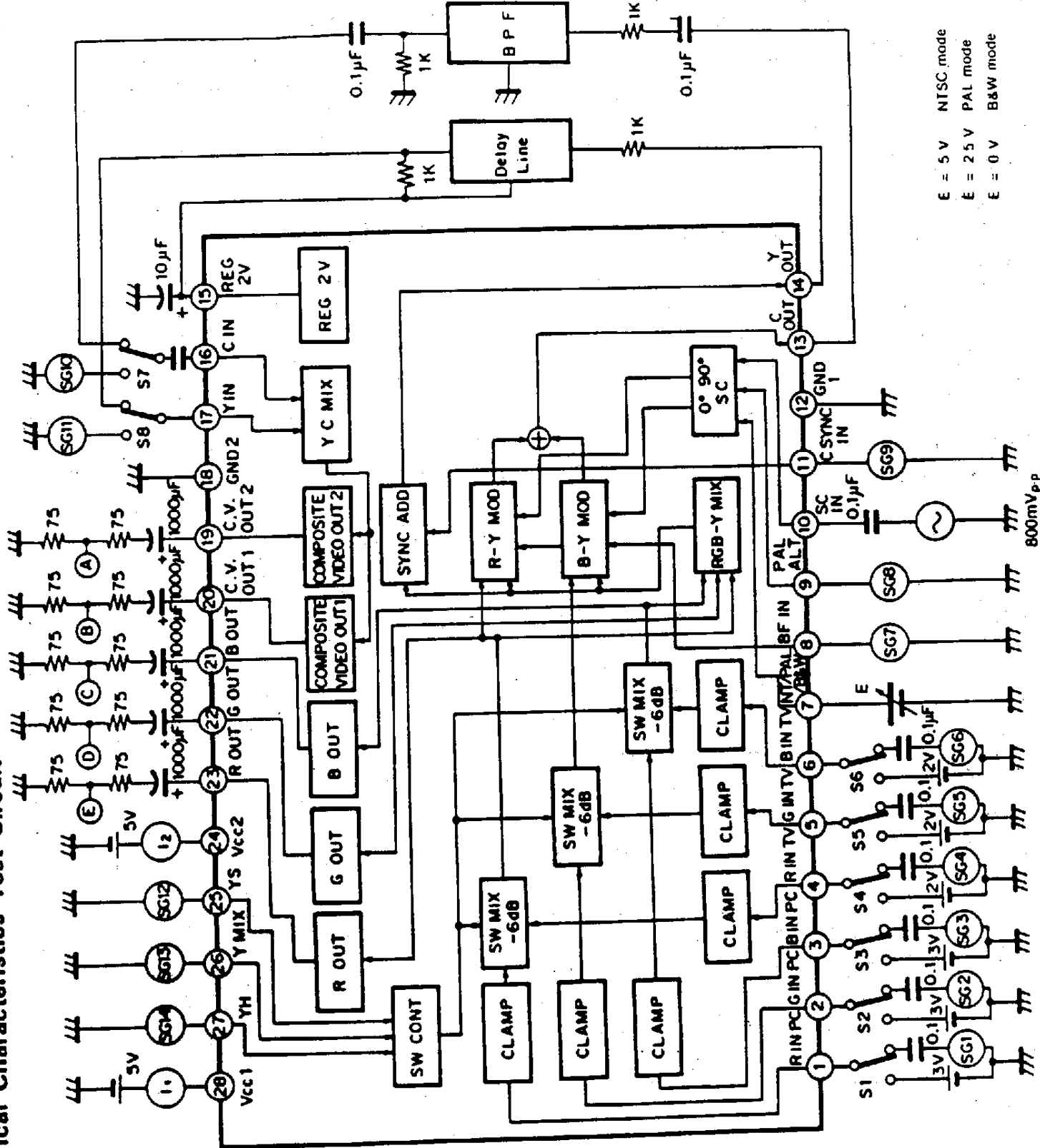

E = 5 V NTSC mode
 E = 2.5 V PAL mode
 E = 0 V B&W mode

800mV_{p-p}

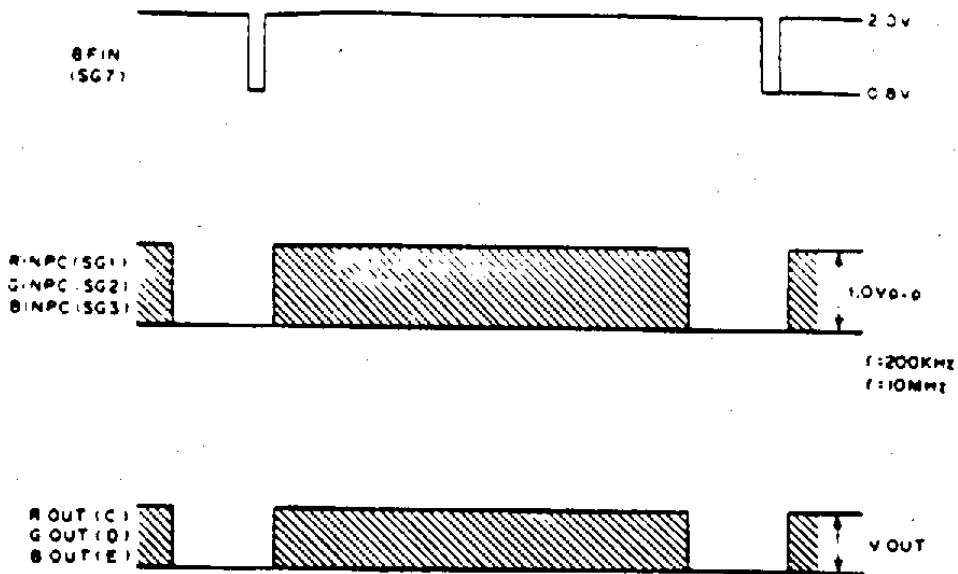

* YS, YMIX, and YM are 0.8 V (PC mode)

Fig. 1

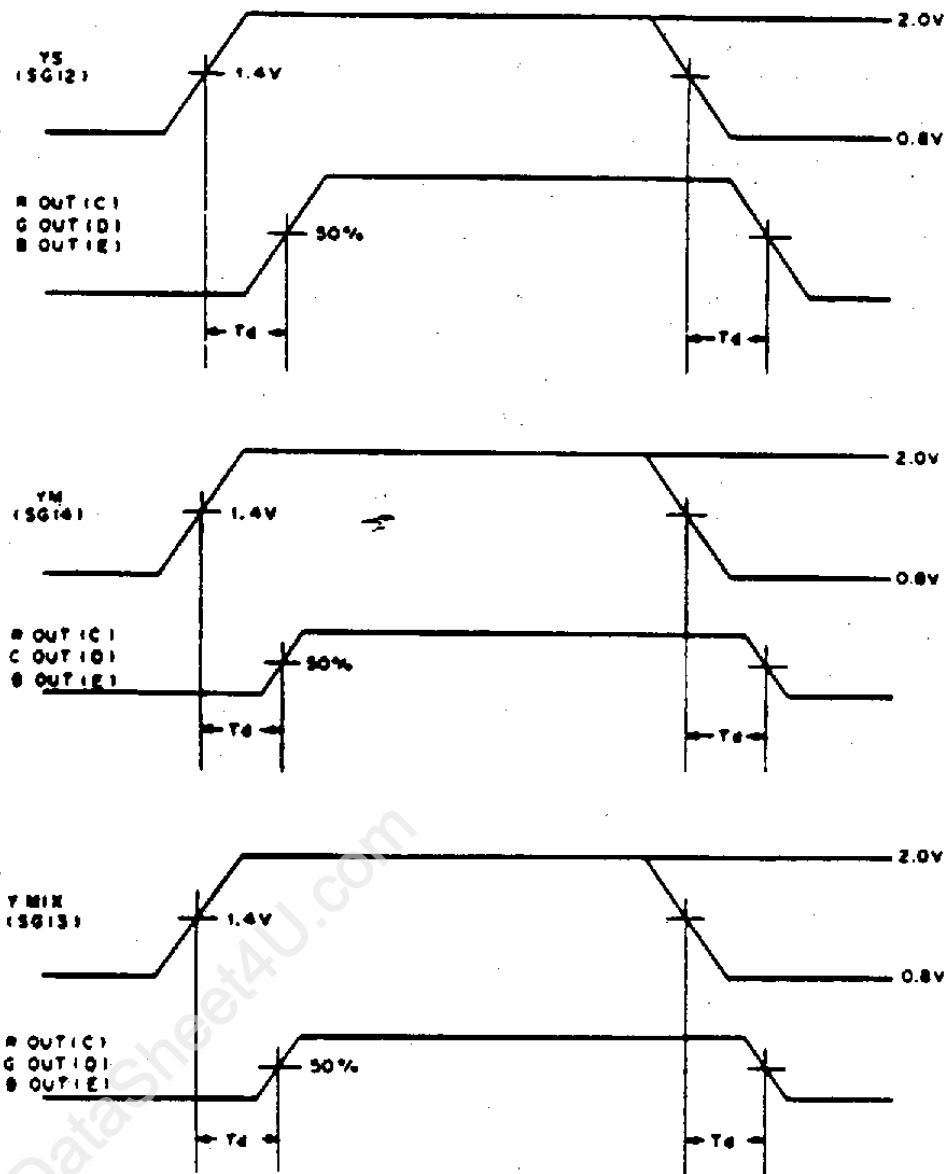

* R-INPC, G-INPC, B-INPC = 3V
R-INTV, G-INTV, B-INTV = 2V

Fig. 2

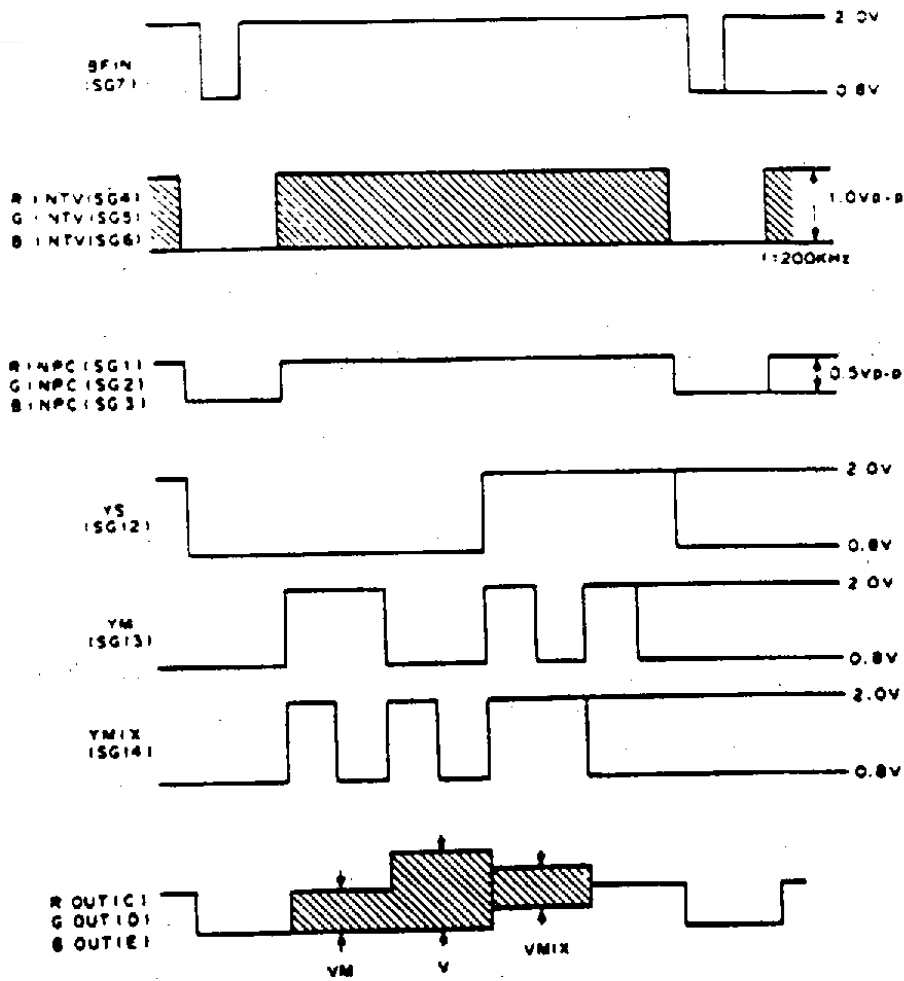
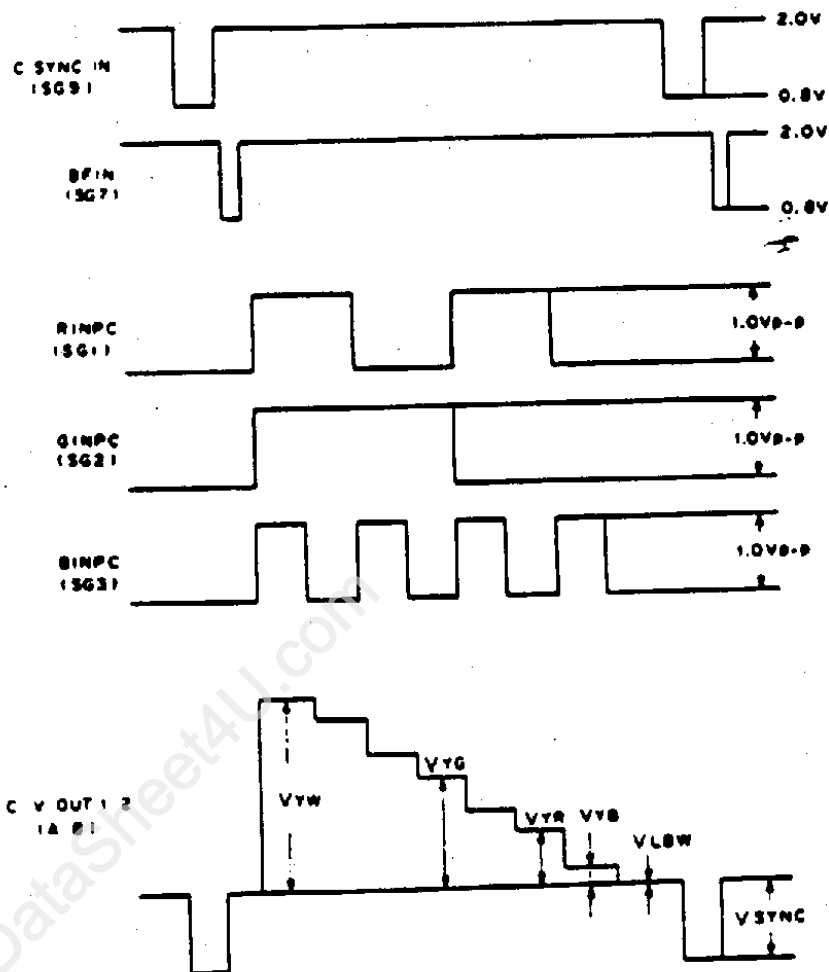

Fig. 3



* YS, YMIX, and YM are 0.8 V (PC model)

Fig. 4

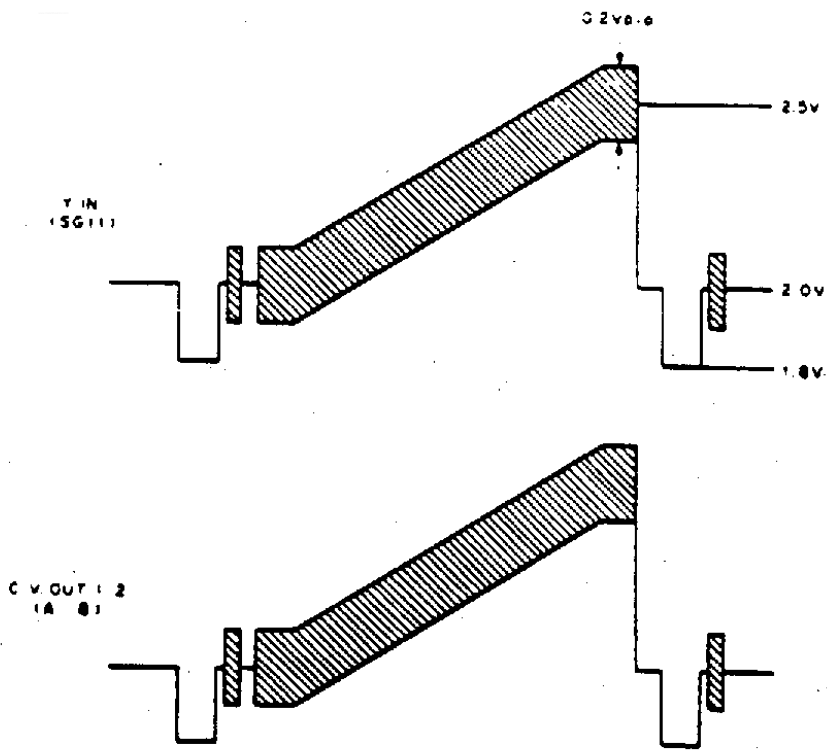
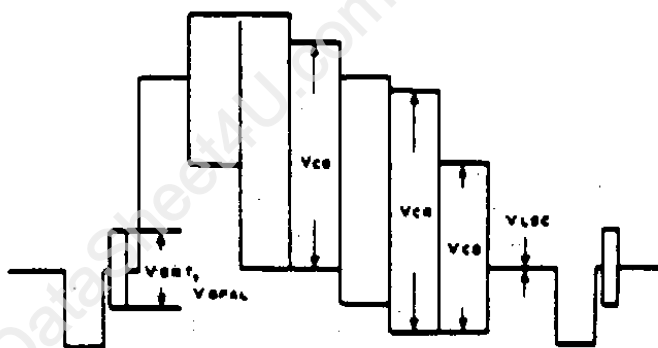
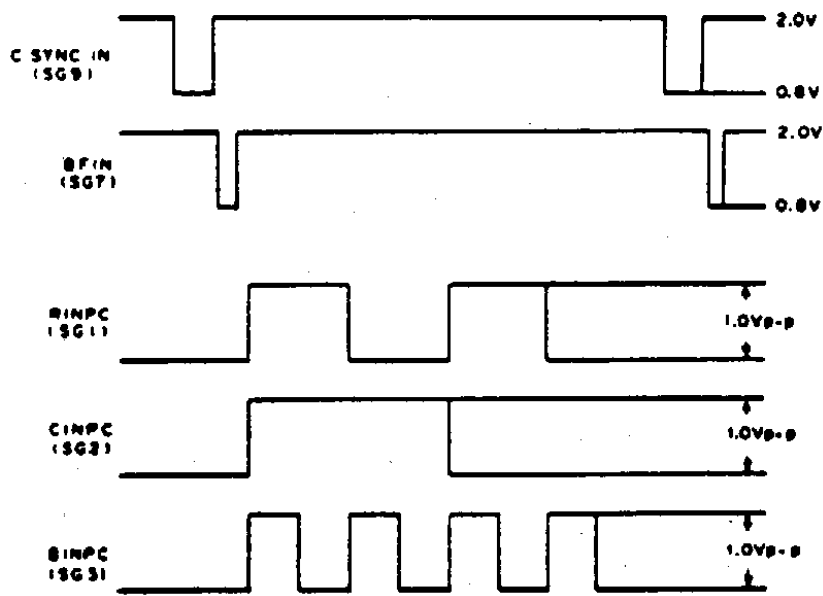

Fig. 5



* YS, YMIX, and YM are 0.6 V (PC model)

Fig. 6

Application Circuit NTSC

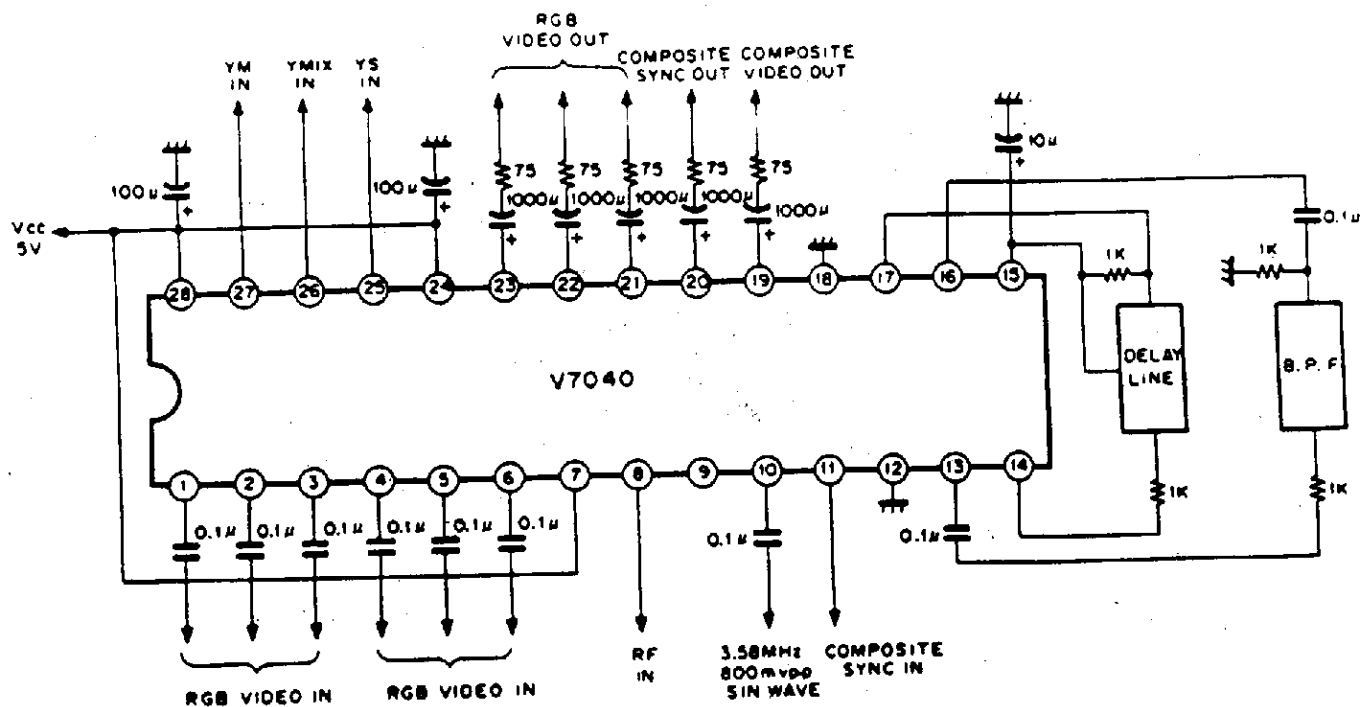

Application Circuit PAL

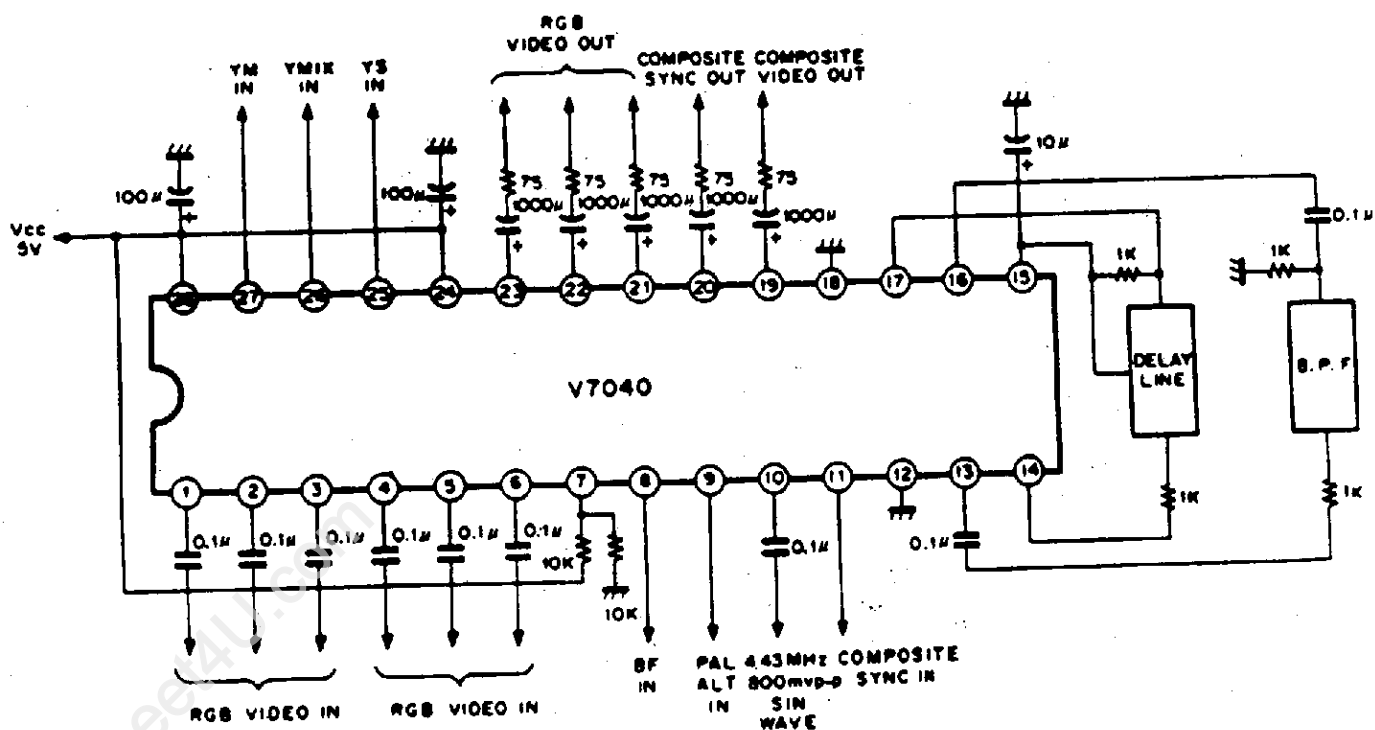

Application Notes

1. RGB signal input

Input the RGB signal to pins 1 to 3 and 4 to 6 via a clamp capacitor.

RGB signal is pedestal clamped by means of the burst flag signal input from pin 8. Input with a sufficiently low impedance.

2. SW mode

RGB signal input from pins 1 to 3 and RGB signal input from pins 4 to 6 are switched into the specified Y mode at the SW circuit. This, by means of the YS, YMIX, YM signals input from pins 25 to 27. The SW mode is in accordance with the following table.

1 PC mode

RGB signal input from pins 1 to 3 is output via SW circuit.

2 TV mode

RGB signal input from pins 4 to 6 is output via SW circuit.

3 MIX mode

RGB signal input from pins 1 to 3 and RGB signal input from pins 4 to 6 are respectively lowered to a level of -6 dB, mixed and output via SW circuit.

4 Halftone mode

RGB signal input from pins 4 to 6, lowers -6 dB level and is output. When superimposing, the background can be darkened and the letters made easier to read. For normal superimposing, ground pin 26 YMIX and pin 27 YM. Input superimpose signal to pin 25 YS.

SW Mode

YS Pin 25	YMIX Pin 26	YM Pin 27	SW Mode
L	L	L	TV
L	L	H	Halftone
L	H	L	TV
L	H	H	Halftone
H	L	L	PC
H	L	H	PC
H	H	L	MIX
H	H	H	MIX

$L \leq 0.8V$

$H \geq 2.0V$

3. NT/PAL/B & W mode

By turning pin 7 (NT/PAL/B & W) to 4V and over, NTSC mode is switched on. By turning it to 3 to 2V, PAL mode is switched on. By turning it to 0.8V or under, B & W mode is switched on. In NTSC mode, burst signal, with B-Y shaft at 0° , is output to 180° direction.

In PAL mode, burst signal, in accordance with PAL ALT signal input from pin 9, is output to 135° , 225° direction. In B & W mode, chroma signal and burst signal are not output. As for V7020, to use in NTSC mode, pin 7 is left open or connected to Vcc.

4. **BF signal**
In accordance with burst flag signal input from pin 8, the burst signal from the composite video signal, is formed. Also, the clamping of RGB signal is executed in accordance with this burst flag signal.
5. **PAL ALT signal**
In accordance with PAL ALT signal input from pin 9, the R-Y shaft direction of the modulator from the chroma signal, is inverted. When pin 9 is at "H", ($\geq 2.0V$) it is set to normal direction. When it is at "L", it is set to the inverted direction.
6. **Subcarrier input**
Input the subcarrier through a 0.4 to 0.8 Vp-p sine wave, via pin 10 (SC IN). With the subcarrier input, too many harmonic waves may adversely affect the phase characteristics of the chroma modulator.
7. **Vcc, GND**
Connect with as low as possible an impedance, pin 12 and GND 1, pin 18 and GND 2. Pin 24 (Vcc 2) and pin 18 (GND 2) are the power supply of 75 Ω driver (RGB OUT circuit, C.V.OUT circuit). As large currents flow in, execute decoupling with a sufficiently large capacitor.
8. **BPF, DL**
Eliminates harmonic waves contained in the chroma demodulator output, at the band-pass filter. Use a delay line matching the band-pass filter delay time.
9. **RGBOUT, C.V.OUT**
At pins 19 and 20 (V.OUT) a composite video signal of about 2 Vp-p is output. At pins 21 through 23 (RGB OUT), an RGB signal (superimposed or else) of about 1.4 Vp-p is output. For the composite sync signal used together with RGB signal, use the composite video signal of pins 19 and 20.
Both C.V.OUT of pins 19, 20 and RGB OUT of pins 21 through 23, can directly drive a load of 75 Ω .
10. **Composite sync signal**
Through the composite sync signal input from pin 11, sync is added to Y signal. At "H" ($\geq 2.0V$) Y signal is activated while at "L" ($\leq 0.8V$) sync is activated.

Descriptions of Operation

1. **Clamp circuit, SW circuit, SW CONT circuit.**
 RGB signal from PC is input to pins 1 through 3 via a clamp capacitor. In the same way, RGB signal from TV is input to pins 4 through 6. Input RGB signals are pedestal clamped together, by means of the clamp circuit operating in accordance with the burst flag signal. Clamped RGB signals are switched at the SW circuit, in accordance with the 4 modes, specified by YS, YMIX and YM signals, which are input from pins 25 through 27.
 RGB signals switched at SW circuit are sent to MTX, MOD and RGB OUT circuits.

2. **MTX circuit, MOD circuit, SC phase shift circuit**
 From RGB signal switched at SW circuit, Y signal is formed by means of MTX circuit. As for these Y and R signals, B signal goes to R-Y MOD circuit and B-Y MOD circuit. Also, this Y signal is sent to SYNC ADD circuit; composite sync signal input from pin 11 is added to it, and it is sent through pin 14 to delay line.
 SC shift phase circuit creates 0° , 90° subcarriers by phase shifting the subcarrier input from pin 10.
 0° and 90° subcarriers are respectively sent to B-Y MOD circuit and R-Y MOD circuit. By means of R with Y signals and B with Y signals, they undergo quadrature double phase modulation to become chroma signals. Chroma signals are sent to BPF via pin 13.

3. **YC MIX circuit**
 Chroma signals from which harmonic waves have been eliminated at BPF, and Y signals that have passed through the delay line are sent to YC MIX circuit via pins 17 and 16. They are mixed, become composite video signals and sent to C.V.OUT circuit.

4. **COMPOSITE VIDEO OUT circuit (C.V.OUT circuit)**
 Composite video signals from YC MIX circuit, are amplified at C.V.OUT circuit into about 2 Vp-p video signals, and output through pins 19 and 20. C.V.OUT circuit, from each of pins 19 and 20 can directly drive a load of 75Ω .

5. **RGB OUT circuit**
 Signal RGB switched at SW circuit is amplified to about 1.4 Vp-p by RGB OUT circuit and output via pins 21 through 23. RGB OUT circuit can directly drive a load of 75Ω .

6. **REG 2V**
 The internal reference voltage is obtained through the band gap reference circuit. The reference voltage becomes the standard for the volume of each of the clamp electric potential, the burst and the sync.