



VB408 VB408B / VB408FI

HIGH VOLTAGE LINEAR REGULATOR POWER I.C.

PRELIMINARY DATA

TYPE	$\Delta V_{IN,OUT}$	I_{LIM}	V_{OUT}
VB408	400 V	40 mA	1.25 to $V_{IN}-30 V$
VB408FI			
VB408B			

- INPUT VOLTAGE UP TO 400 V DC OR 285 V RMS RECTIFIED
- OUTPUT VOLTAGE ADJUSTABLE FROM 1.25 TO $V_{IN}-30V$
- OUTPUT CURRENT LIMITED TO 40 mA
- THERMAL SHUT-DOWN PROTECTION
- SHORT CIRCUIT PROTECTION

DESCRIPTION

The VB408, VB408B, VB408FI are fully protected positive adjustable voltage regulators made using a proprietary High Voltage VIPower™ technology. The device can be connected to a D.C. source (up to 400V) or in off-line application directly to the rectified main (110V/230V). It is particularly suitable to be used in the manufacture of DC/DC converters, AC/DC converters,

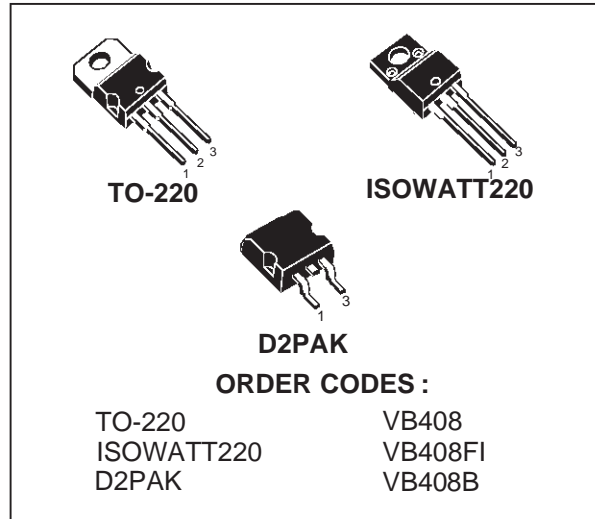

start-up circuits, pneumatic valve drivers and current sources. The device is able to drive resistive or inductive loads with an output voltage from 1.25V to $V_{IN}-30V$ providing an internally limited output current; it has built in short circuit and thermal shutdown protections. The device does not provide galvanic insulation from main.

BLOCK DIAGRAM

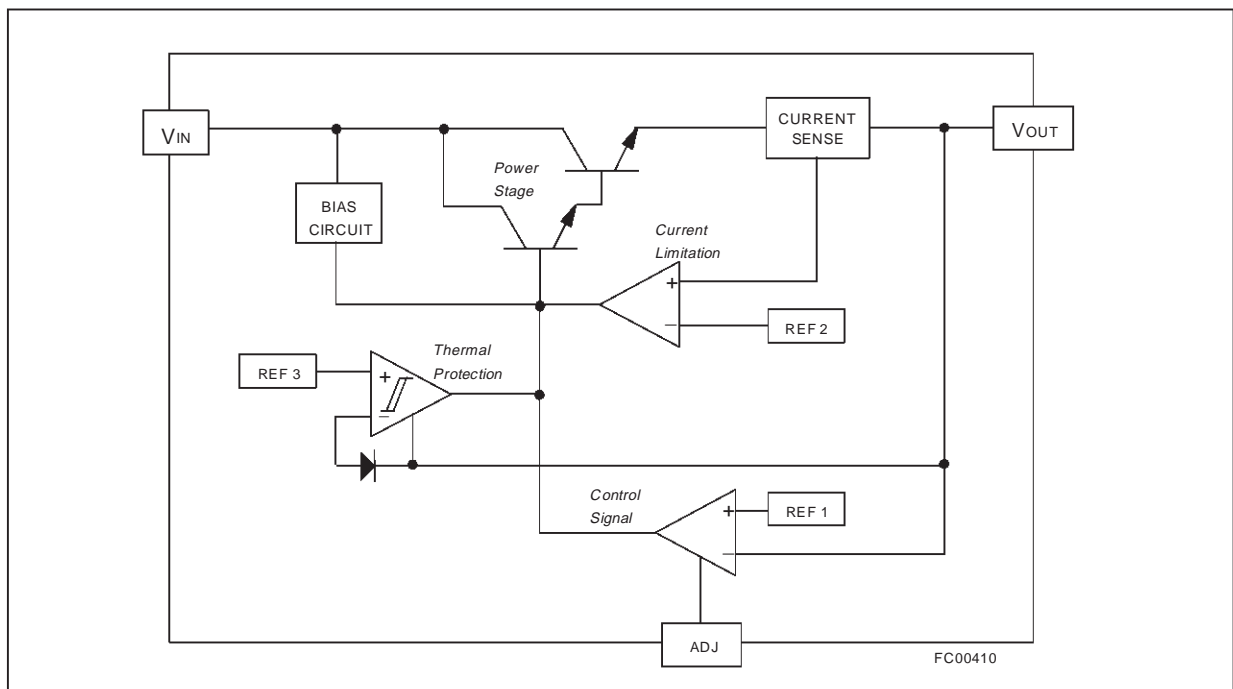

ABSOLUTE MAXIMUM RATING

Symbol	Parameter	Value			Unit
		TO-220	ISOWATT220	D2PAK	
$\Delta V_{IN,OUT}$	Input to Output Voltage at 20 mA	- 0.2 to 420			V
I_{OUT}	Output current	Internally limited			mA
V_{ESD}	Electrostatic discharge (R=1.5k Ω , C=100pF)	2000			V
P_{tot}	Power dissipation at T _C =25°C	89	31	89	W
T_j	Junction operating temperature	- 40 to 150			°C
T_{STG}	Storage temperature	- 55 to 150			°C

THERMAL DATA

Symbol	Parameter	Value			Unit
		TO-220	ISOWATT220	D2PAK	
$R_{thj-case}$	Thermal resistance junction-case (MAX)	1.4	4	1.4	°C/W
$R_{thj-amb}$	Thermal resistance junction-ambient (MAX)	60	60	35 (*)	°C/W

(*) When mounted using the minimum recommended pad size on FR-4 board (1 inch²)

CONNECTION DIAGRAM (TOP VIEW)

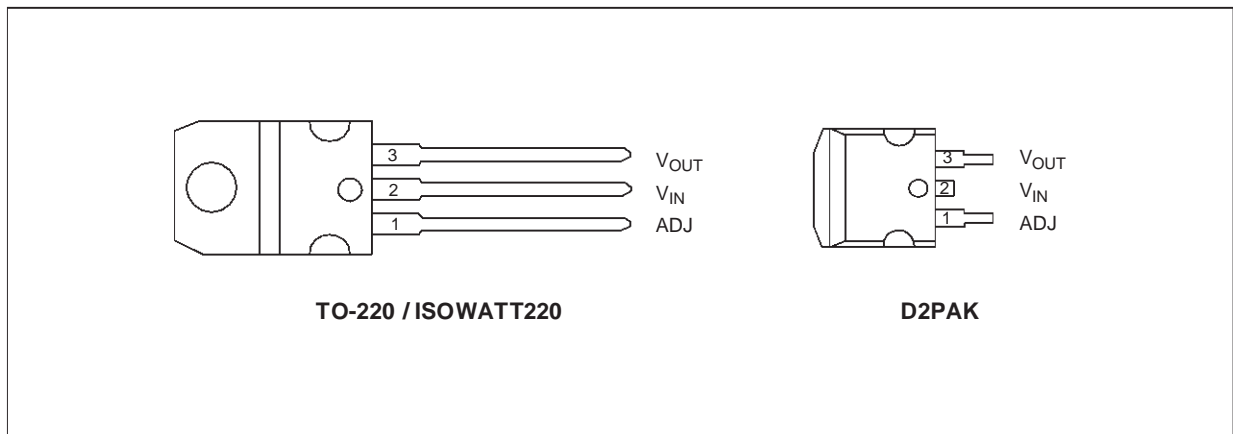

ELECTRICAL CHARACTERISTICS (V_{IN}=300VDC; -25°C<T_j<125°C; I_{LOAD}=15mA; V_{ADJ}=0V unless otherwise specified)

Symbol	Parameter	Test Conditions	Min	Typ	Max	Unit
V _{IN}	Input Voltage		30		400	V
V _{IN} -V _{OUT}	Input to Output Voltage				30	V
V _{REF}	Output Reference Voltage	V _{ADJ} =0V	1.20	1.24	1.28	V
$\Delta V_{OUT}/\Delta V_{IN}$	Line Regulation	V _{ADJ} =0V; V _{IN} =30 to 400 VDC			100	$\mu V/V$
$\Delta V_{OUT}/\Delta I_{LOAD}$	Load Regulation	V _{ADJ} =0V; I _{LOAD} =1 to 20 mA			6	mV/mA
I _{ADJ}	Adjustment Pin Current		50	70	90	μA
I _{BIAS}	Minimum Load Current		1.2			mA
I _{LIM}	Output Current Limit		40		60	mA
T _{jsh}	Junction Temperature Shutdown Limit		135	150		°C
ΔT_{jsh}	Junction Temperature Shutdown Hysteresis			25		°C

Figure 1: Typical application diagram

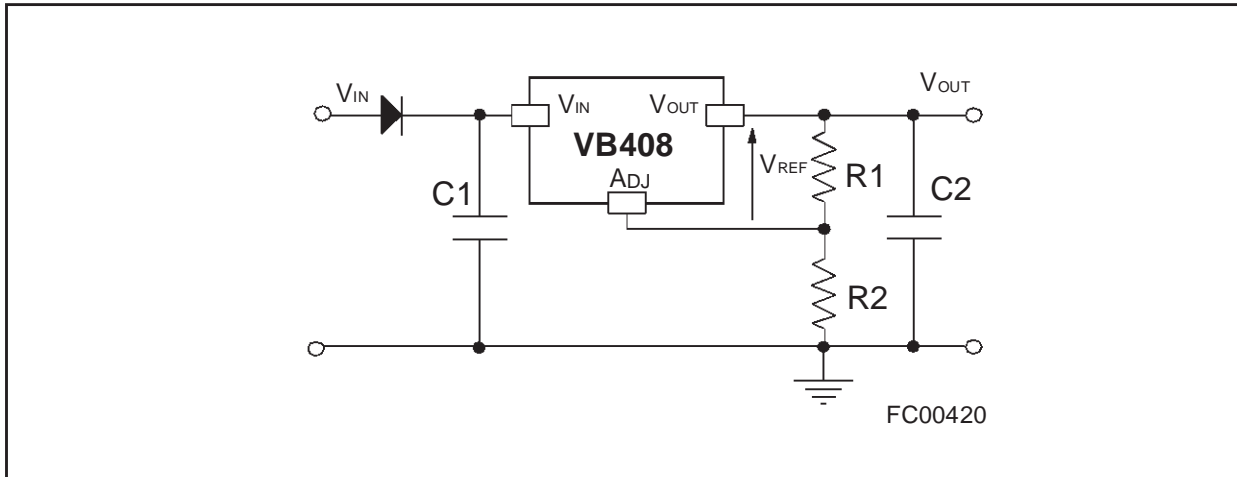

OPERATION DESCRIPTION

The VB408, VB408B, VB408FI are positive voltage regulators continuously adjustable from 1.25V to the input voltage minus a dropout of 30V through an external divider. In order to set the proper internal reference voltage, a typical 70µA current has to be drawn from the ADJ pin. Considering that, it results:

$$V_{OUT} = V_{REF} (1 + R_2/R_1) + I_{ADJ}R_2$$

To simplify this formula, neglecting I_{ADJ} with respect to the term

$$V_{REF}/R_1$$

R_1 must be chosen so to obtain a minimum 1.2mA current flowing through the divider. In such a way the V_{OUT} value will be affected by an error <5%. The current set resistor R_1 should be tied directly to the output terminal of the regulator rather than near the load. This eliminates line drops from appearing in series with the reference and degrading regulation. The output voltage can also be set by a zener diode put between the adjustment pin and ground (Figure 2). The biasing current of the zener is properly chosen by R_1 resistor. The zener diode improves the ripple rejection and reduces the value of the worst case output voltage error. In this case the output voltage is given by:

$$V_{OUT} = V_{REF} + V_Z$$

In order to reduce excessive output ringing, a minimum output capacitor C_2 of 0.1µF is suggested. This capacitor will improve loop stability and output impedance. The VB408/VB408B/VB408FI can be connected both to a DC source or to a 285V r.m.s. line by a rectifier diode that prevents a negative voltage to be applied to the device. In the first case the input capacitor C_1 is not needed, whereas in the second case a high value of C_1 (> 1µF) must be chosen. In fact, in this kind of application, C_1 has to supply to the input pin the minimum allowed voltage

during the negative half wave. Obviously bigger C_1 value, more constant the input voltage is and consequently smaller the output voltage ripple. For the right choice of the input capacitor, you have also to remember that increasing its value you will obtain an increased power dissipation, and a heatsink could be required. The right heatsink is determined by the load current, input voltage and ambient temperature. In case of pulse or A.C. operation the junction temperature is limited by the thermal capacitances since the package and the heatsink masses are able to absorb heat. If the junction temperature reaches the thermal shutdown limit the output stage of the regulator is turned-off so that only the biasing current of the device can flow into the input pin. Thermal hysteresis is added just to prevent oscillations. The device is able to provide minimum 40 mA for a time that is function of dissipated power and consequently of the used heatsink. In general the device is also suitable in electronically switched motor housekeeping supply, consumer equipments controls power supply or constant current source.

APPLICATION EXAMPLE

The most common application for the device is in the DC/DC converters with an input voltage up to 400 VDC and a C_2 suggested value of 0,1µF.

Using an external rectifier an AC/DC converter can be easily implemented, in this case the device can operate with an AC voltage up to 285VRMS. In this case must be used a minimum 1µF input capacitor to provide the load current during the negative half cycle of the main. Another important circuit that can be implemented is the start up function for low voltage input PWM ICs directly from a high voltage source (see figure 3).

Figure 2: Regulation with Zener

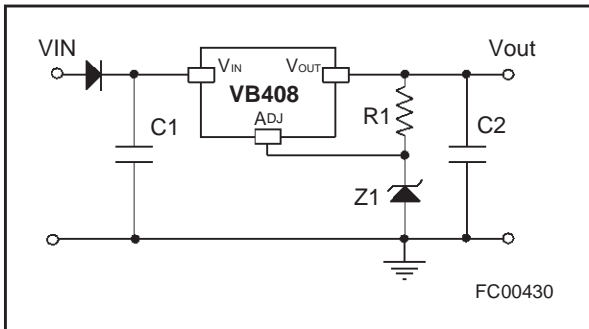
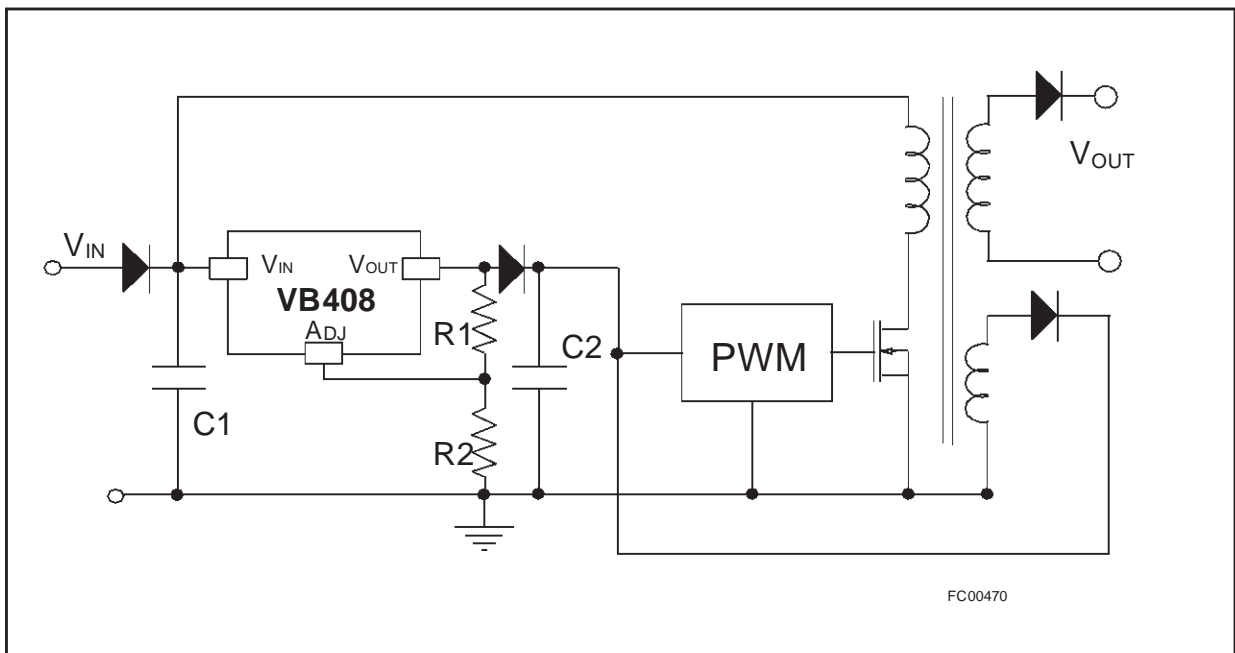
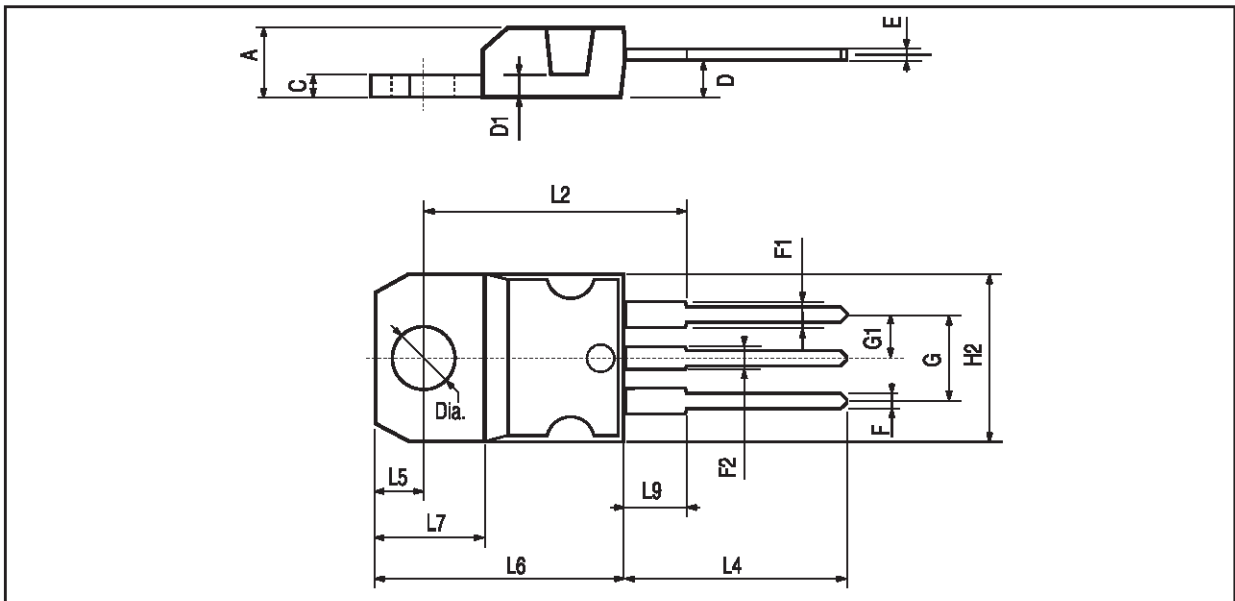

Figure 3: Start-up circuit



TO-220 MECHANICAL DATA

DIM.	mm.			inch		
	MIN.	TYP	MAX.	MIN.	TYP.	MAX.
A	4.40		4.60	0.173		0.181
C	1.23		1.32	0.048		0.051
D	2.40		2.72	0.094		0.107
D1		1.27			0.050	
E	0.49		0.70	0.019		0.027
F	0.61		0.88	0.024		0.034
F1	1.14		1.70	0.044		0.067
F2	1.14		1.70	0.044		0.067
G	4.95		5.15	0.194		0.203
H2	10.0		10.40	0.393		0.409
L2		16.4			0.645	
L4	13.0		14.0	0.511		0.551
L5	2.65		2.95	0.104		0.116
L6	15.25		15.75	0.600		0.620
L7	6.2		6.6	0.244		0.260
L9	3.5		3.93	0.137	0.154	
DIA.	3.75		3.85	0.147		0.151



ISOWATT220 MECHANICAL DATA

DIM.	mm.			inch		
	MIN.	TYP	MAX.	MIN.	TYP.	MAX.
A	4.4		4.6	0.173		0.181
B	2.5		2.7	0.098		0.106
D	2.5		2.75	0.098		0.108
E	0.4		0.7	0.015		0.027
F	0.75		1	0.030		0.039
F1	1.15		1.7	0.045		0.067
F2	1.15		1.7	0.045		0.067
G	4.95		5.2	0.195		0.204
G1	2.4		2.7	0.094		0.106
H	10		10.4	0.393		0.409
L2		16			0.630	
L3	28.6		30.6	1.126		1.204
L4	9.8		10.6	0.385		0.417
L6	15.9		16.4	0.626		0.645
L7	9		9.3	0.354		0.366
	3		3.2	0.118		0.126

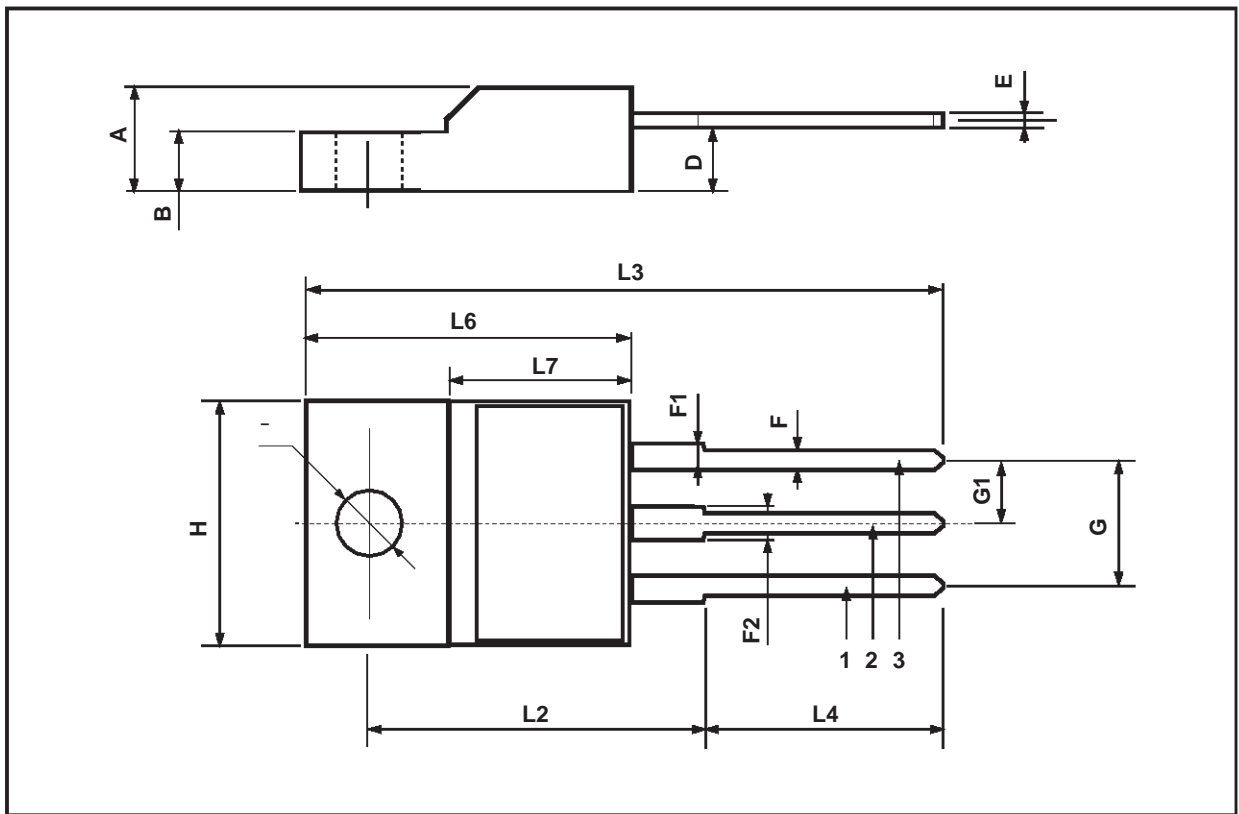

D2PAK MECHANICAL DATA

DIM.	mm.			inch		
	MIN.	TYP	MAX.	MIN.	TYP.	MAX.
A	4.30		4.60	0.169		0.181
A1	2.49		2.69	0.098		0.106
B	0.70		0.93	0.027		0.036
B2	1.25		1.4	0.049		0.055
C	0.45		0.6	0.017		0.023
C2	1.21		1.36	0.047		0.053
D	8.95		9.35	0.352		0.368
E	10		10.28	0.393		0.404
G	4.88		5.28	0.192		0.208
L	15		15.85	0.590		0.625
L2	1.27		1.4	0.050		0.055
L3	1.4		1.75	0.055		0.068

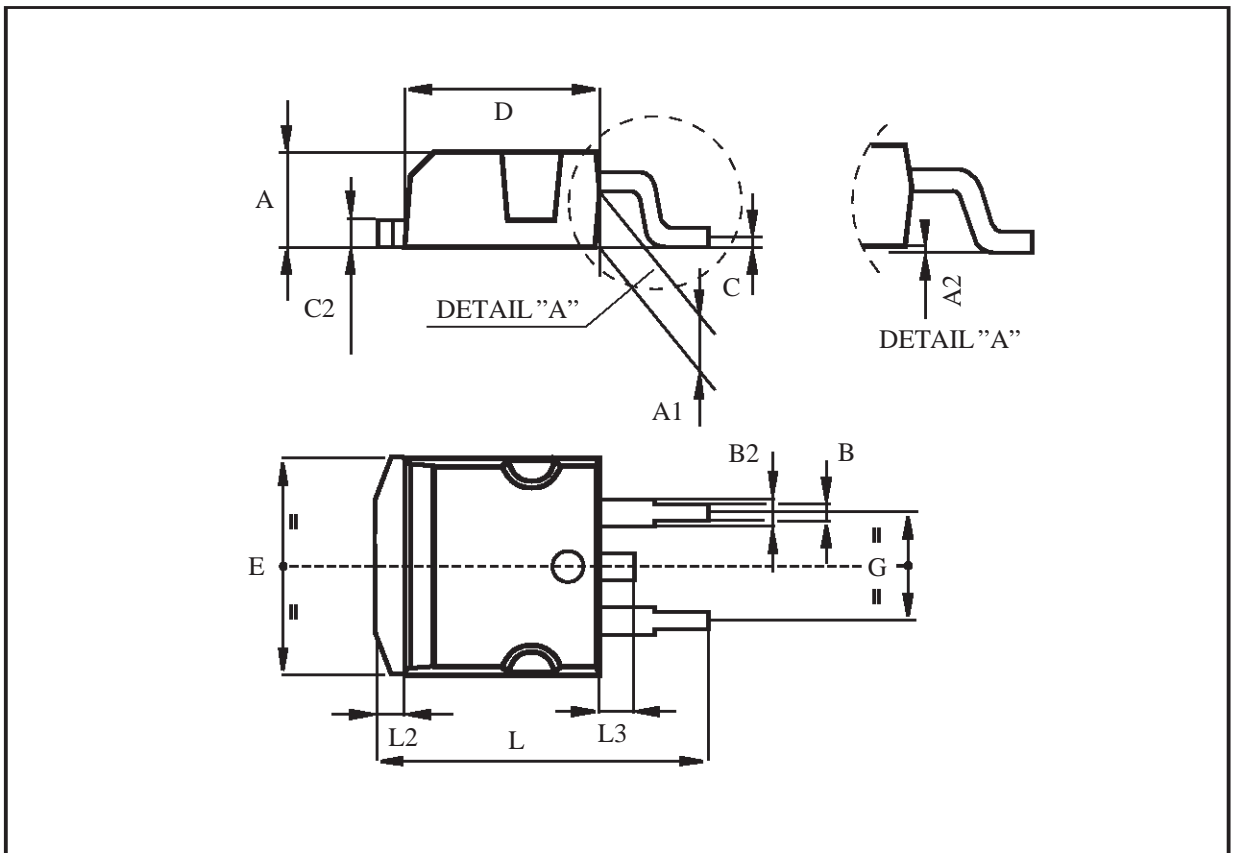

Information furnished is believed to be accurate and reliable. However, STMicroelectronics assumes no responsibility for the consequences of use of such information nor for any infringement of patents or other rights of third parties which may result from its use. No license is granted by implication or otherwise under any patent or patent rights of STMicroelectronics. Specifications mentioned in this publication are subject to change without notice. This publication supersedes and replaces all information previously supplied. STMicroelectronics products are not authorized for use as critical components in life support devices or systems without express written approval of STMicroelectronics.

The ST logo is a registered trademark of STMicroelectronics

© 1999 STMicroelectronics - Printed in ITALY- All Rights Reserved.

STMicroelectronics GROUP OF COMPANIES

Australia - Brazil - Canada - China - France - Germany - Italy - Japan - Korea - Malaysia - Malta - Mexico - Morocco -
The Netherlands- Singapore - Spain - Sweden - Switzerland - Taiwan - Thailand - United Kingdom - U.S.A.

<http://www.st.com>