

1.SCOPE

Shoulder's SAW filter series have broad line up products meeting all broadcast standard including NTSC,PAL and SECAM systems. These filters are composed of two interdigital transducers on a single-crystal. piezoelectrical chip. they are used in electronic equipments such as TV and so on.

2.Construction

2.1 Dimension and materials

Manufacturer's name : HAODA ELECTRONICS Co. LTD(CHINA)

Type : VF45A2M

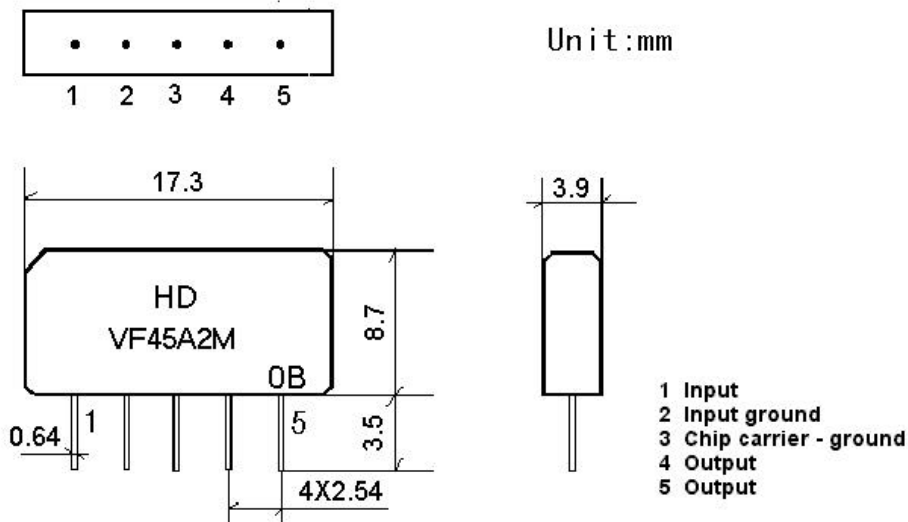

0: year(0,1,2,3,4,5,6,7,8,9)

B:product in this quarter(A:1~3,B:4~6,C:7~9,D:10~12)

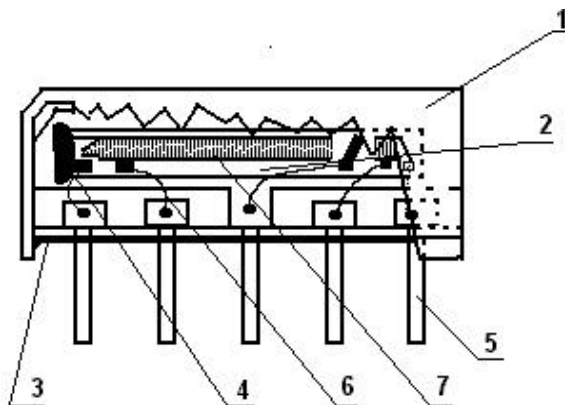

Components	Materials
1.Outer casing	PPS
2.Substrate	Lithium niobate
3.Base	Epoxy resin
4.Absorber	Epoxy resin
5.Lead	Cu alloy+Au plate
6.Bonding wire	AlSi alloy
7.Electrode	Al

2.2. Circuit construction, measurement circuit

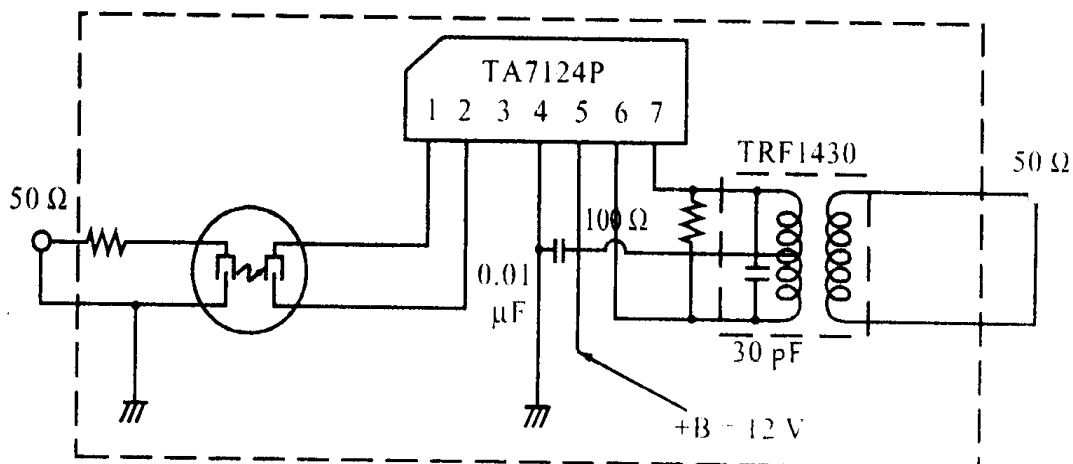

3.Characteristics

Standard atmospheric conditions

Unless otherwise specified , the standard rang of atmospheric conditions for making measurements and tests is as follows;

- Ambient temperature : 15 to 35
- Relative humidity : 25% to 85%
- Air pressure : 86kPa to 106kPa

Operating temperature rang

Operating temperature rang is the rang of ambient temperatures in which the filter can be

operated continuously. -10 ~ +60

Storage temperature rang

Storage temperature rang is the rang of ambient temperatures at which the filter can be stored

without damage.

Conditions are as specified elsewhere in these specifications. -40 ~ +70

Reference temperature +25

3.1 Maximum Rating

DC voltage	VDC	12	V	Between any terminals
------------	-----	----	---	-----------------------

3.2 Electrical Characteristics

T_A=25

Item	Freq	min	typ	max	
Insertion attenuation	44.00MHz	26.8	28.8	30.8	dB
Relative attenuation Reference level (at 45.75MHz)	45.75MHz	-	0	-	dB
	42.17MHz	5.2	6.2	7.2	dB
	44.00MHz	5.1	6.1	7.1	dB
	41.25MHz	-	-	-15.0	dB
	39.75MHz	-	-	-35.0	dB
	47.25MHz	-	-	-38.0	dB
Sidelobe	33.75~39.75MHz	-	-	-26.0	dB
	47.25~53.25MHz	-	-	-26.0	dB
Temperature coefficient of frequency			-18		Ppm/k

3.3 Environmental Performance Characteristics

Item Test condition	Allowable change of absolute Level at center frequency(dB)
High temperature test 70 1000H	< 1.0
Low temperature test -40 1000H	< 1.0
Humidity test 40 90-95% 1000H	< 1.0
Thermal shock -20 ==25 ==80 20 cycle 30M 10M 30M	< 1.0
Solder temperature test Sold temp.260 for 10 sec.	< 1.0
Soldering Immerse the pins melt solder at 260 +5/-0 for 5 sec.	More then 95% of total area of the pins should be covered with solder

3.4 Mechanical Test

Item Test condition	Allowable change of absolute Level at center frequency(dB)
Vibration test 600-3300rpm amplitude 1.5mm 3 directions 2 H each	<1.0
Drop test On maple plate from 1 m high 3 times	<1.0
Lead pull test Pull with 1 kg force for 30 seconds	<1.0

Lead bend test 90° bending with 500g weigh 2 times	<1.0
---	------

3.5 Voltage Discharge Test

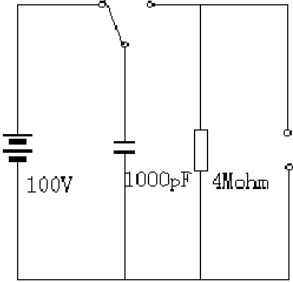
Item Test condition	Allowable change of absolute Level at center frequency(dB)
Surge test Between any two electrode 	<1.0