

VG (Parallel Shaft) 100W

Performance Table

Values in parentheses in the performance tables and dimension diagrams indicate models with brakes.

[Items to Note]

- Shaded cells (■) in the performance table indicate that when a Clockwise (CW) Driver is ordered, the output shaft turns clockwise when the unit is oriented as shown in the figure at right. Specify Clockwise (CW) or Counter-Clockwise (CCW) in order to change the direction of rotation.
- Dimensions indicated in italic figures are given a black coating, so the corresponding hole should be enlarged at least 0.5 mm more than the figure given.
- Key dimensions and tolerances for output shafts are specified by JIS B 1301-1976.



Motor Capacity	Frame No.	Nominal Reduction Ratio	Actual Reduction Ratio	Output Shaft Rotational Speed	Output Shaft Allowable Torque (Sustained)		Output Shaft Allowable O.H.L.		Shape and Dimensions Diagram	
				rpm	N·m	kgf·m	N	kgf	VGLC (VGLD)	VGKC (VGKD)
100W	15	1/ 5	1/ 5	30 ~500	1.67	0.17	150	15	P.A4 Fig. A-5 2.3kg (2.8kg)	P.A5 Fig. A-7 2.3kg (2.8kg)
		1/ 10	1/ 10	15 ~250	3.43	0.35	340	35		
		1/ 15	1/ 15	10 ~166	5.10	0.52	440	45		
		1/ 20	1/ 20	7.5~125	6.86	0.70	540	55		
		1/ 25	1/ 25	6.0~100	8.53	0.87	590	60		
		1/ 30	1/ 30	5.0~ 83	9.80	1.0	690	70		
		1/ 40	1/ 40	3.8~ 62	12.7	1.3	780	80		
		1/ 50	1/ 50	3.0~ 50	16.7	1.7	880	90		
	1/ 60	1/ 60	2.5~ 41	19.6	2.0	880	90			
	22	1/ 80	21/ 1634	1.9~ 31	25.5	2.6	1570	160	P.A5 Fig. A-6 4.5kg (5kg)	P.A5 Fig. A-8 4.5kg (5kg)
		1/100	7/ 684	1.5~ 25	32.3	3.3	1670	170		
		1/120	147/17974	1.3~ 20	39.2	4.0	1670	170		
		1/160	21/ 3268	1.0~ 15	51.9	5.3	1760	180		
		1/200	21/ 4085	0.8~ 12	64.7	6.6	1760	180		

(Notes) 1. Allowable O.H.L. is the value at the center of the output shaft.
 2. The value for the output shaft rotational speed (p.T10) gives the variable speed range according to the nominal reduction ratio.

Foot Mount Model 100W

Fig. A-5 **VGLC15-5~60N100**^{L1}_{L2}^{L3}_{L4}
(VGLD15-5~60N100^{L1}_{L2}^{L3}_{L4})

CAD Data:VGLC15-100L
 (CAD Data:VGLD15-100L)

Rough Weight: 2.3kg(2.8kg)

Fig. A-6

VGLC22-80~200N100^{L1}_{L2}^{L3}<sub>L4
(**VGLD22-80~200N100**^{L1}_{L2}^{L3}_{L4)}</sub>

CAD Data:VGLC22-100L
(CAD Data:VGLD22-100L)

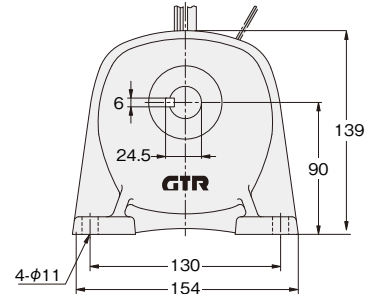
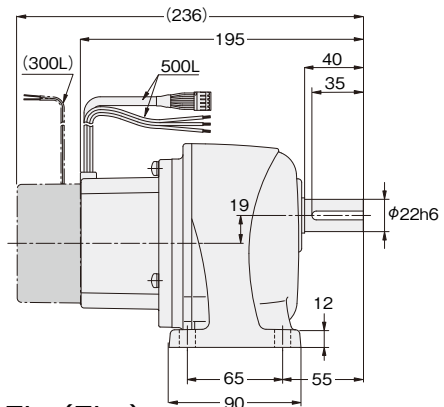

Rough Weight: 4.5kg(5kg)

Flange Mount Model 100W

Dimensions indicated in italic figures are given a black coating, so the corresponding hole should be enlarged at least 0.5 mm more than the figure given.

Fig. A-7

VGKC15-5~60N100^{L1}_{L2}^{L3}<sub>L4
(**VGKD15-5~60N100**^{L1}_{L2}^{L3}_{L4)}</sub>

CAD Data:VGKC15-100L
(CAD Data:VGKD15-100L)

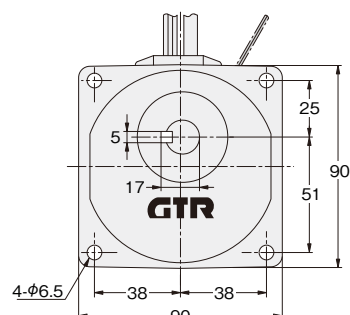
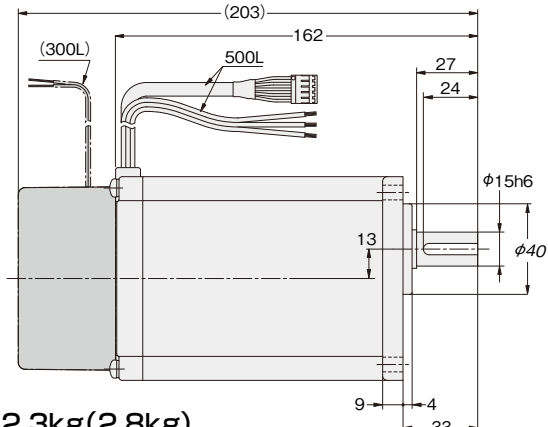

Rough Weight: 2.3kg(2.8kg)

Fig. A-8

VGKC22-80~200N100^{L1}_{L2}^{L3}<sub>L4
(**VGKD22-80~200N100**^{L1}_{L2}^{L3}_{L4)}</sub>

CAD Data:VGKC22-100L
(CAD Data:VGKD22-100L)

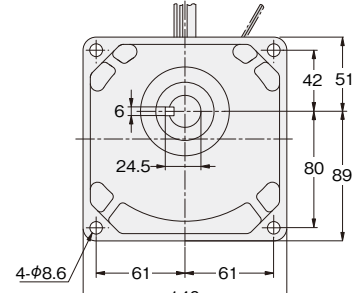
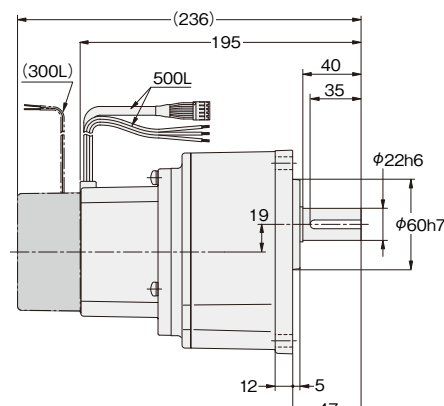

Rough Weight: 4.5kg(5kg)