

SMD transformers for automotive grade
Transformers for IGBT/FET



VGT series

FEATURES

- A power transformer for the IPM drive of the motor inverter.
- High flux density cores have been adopted to achieve miniaturization.
- The dielectric strength voltage is 2.6 kV.
- Operating temperature range: -40 to +130°C (including self-temperature rise)







APPLICATION

- For Intelligent Power Module drive power supply of an inverter motor
- Application guides: [Automotive \(xEV\)](#)

PART NUMBER CONSTRUCTION

VGT	10SEE	-	200	S2A5
Series name	Core shape		Type name	Internal code

PRODUCT LINEUP

	Inductance*		Leakage inductance*	Withstanding voltage		Turn ratio
	NP (μH)	Tolerance	NP(NS all shorted) (μH)max.	NP, NF-NS Sense: 1mA	Coil-Core Sense: 1mA	
VGT10SEE-200S2A5 	20	±25%	0.5	2.6kVrms/1min	1.3kVrms/1min	NP:NF:NS1:NS2 =1:1:1:1
VGT12EEM-200S1A4 	10	±20%	0.2	2.6kVrms/1min	1.3kVrms/1min	NP:NF:NS =1:1.6:2.9
VGT15EFD-200S3A6 	8.0	±20%	0.2	2.6kVrms/1min	1.3kVrms/1min	NP:NF:NS1:NS2:NS3 =1:2.8:2.8:2.8:2.8
VGT15SEFD-200S1A4 	10	±20%	0.2	2.6kVrms/1min	1.3kVrms/1min	NP:NF:NS =1:1.8:3.3
VGT15SEFD-250S4A7 	2.6	±20%	0.2	2.6kVrms/1min	1.3kVrms/1min	NP:NF:NS1:NS2:NS3:NS4 =1:3:3:3:3:3
VGT22EPC-200S6A12 	2.5	±15%	0.3	2.6kVrms/1min	1.3kVrms/1min	NP:NS1-P:NS1-N:NS2-P:NS2-N: NS3-P:NS3-N:NS4-P:NS4-N =1:1.2:0.7:1.2:0.7:1.2:0.7:1.2:0.7

* Measuring conditions: 100kHz/1V

VGT10SEE-200S2A5

ELECTRICAL CHARACTERISTICS

CHARACTERISTICS SPECIFICATION TABLE

Part No.	Inductance*		Leakage inductance* NP(NS all shorted) (μ H)max.	Withstanding voltage NP, NF-NS Sense: 1mA		Turn ratio
	NP (μ H)	Tolerance		Coil-Core Sense: 1mA		
VGT10SEE-200S2A5	20	$\pm 25\%$	0.5	2.6kVrms/1min	1.3kVrms/1min	NP:NF:NS1:NS2 =1:1:1:1

SHAPE & DIMENSIONS

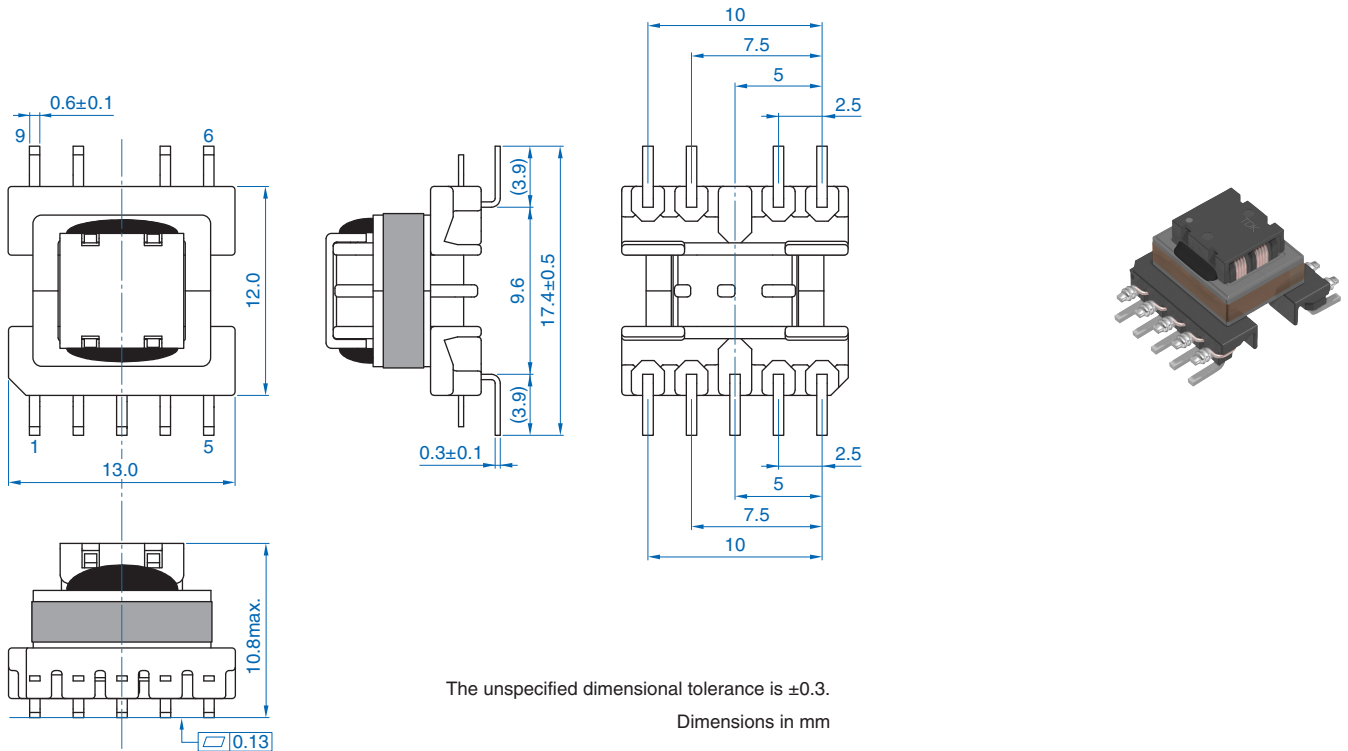

RECOMMENDED LAND PATTERN

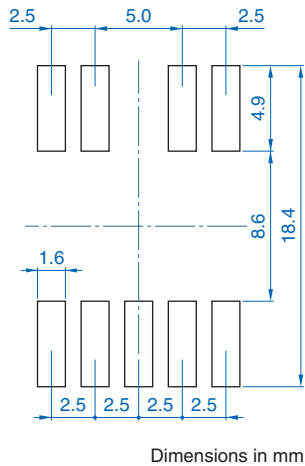

CIRCUIT DIAGRAM

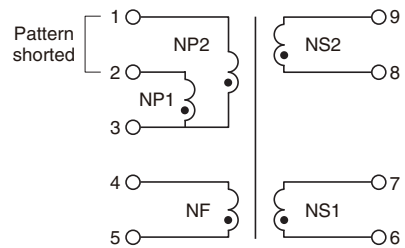

VGT12EEM-200S1A4

ELECTRICAL CHARACTERISTICS

CHARACTERISTICS SPECIFICATION TABLE

Part No.	Inductance*		Leakage inductance* NP(NS all shorted) (μ H)max.	Withstanding voltage		Turn ratio
	NP (μ H)	Tolerance		NP, NF-NS Sense: 1mA	Coil-Core Sense: 1mA	
VGT12EEM-200S1A4	10	$\pm 20\%$	0.2	2.6kVrms/1min	1.3kVrms/1min	NP:NF:NS =1:1.6:2.9

SHAPE & DIMENSIONS

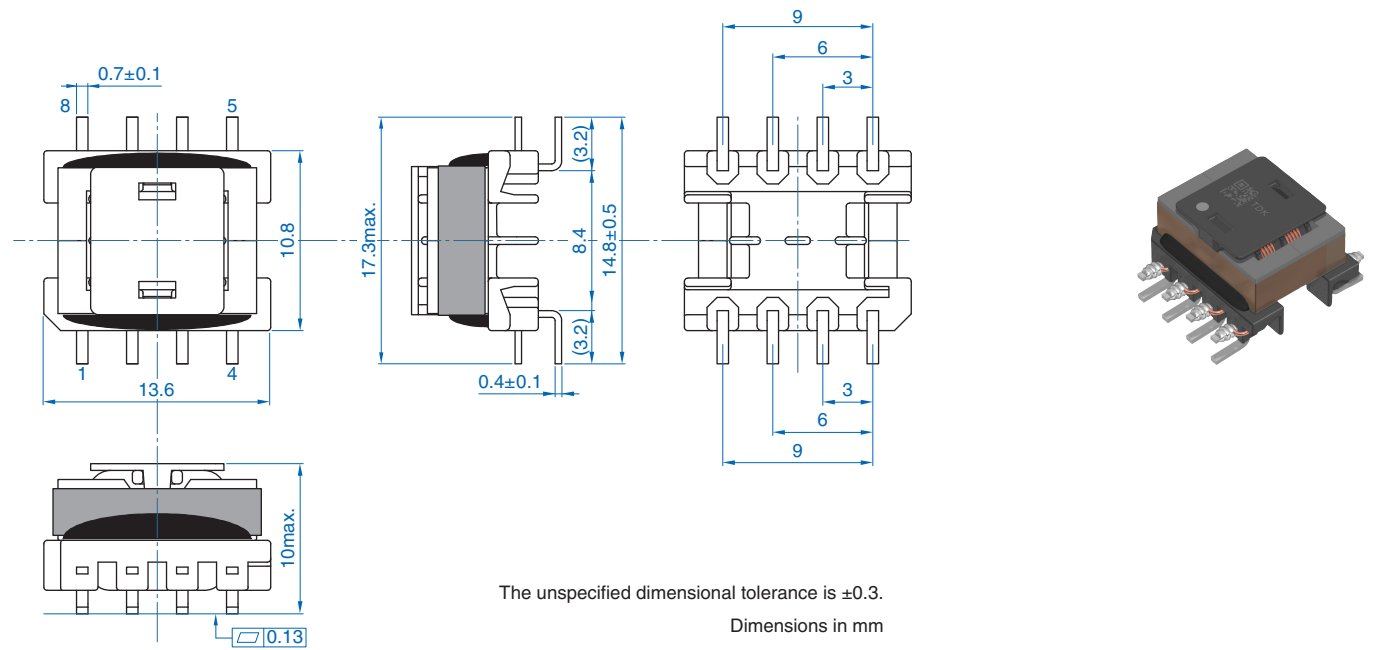

RECOMMENDED LAND PATTERN

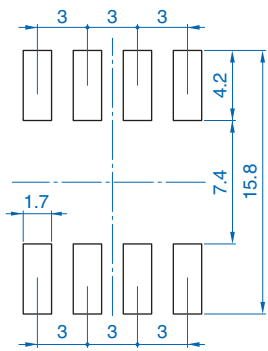

CIRCUIT DIAGRAM

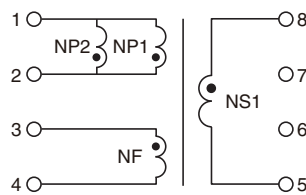

VGT15EFD-200S3A6

ELECTRICAL CHARACTERISTICS

CHARACTERISTICS SPECIFICATION TABLE

Part No.	Inductance*		Leakage inductance*	Withstanding voltage		Turn ratio
	NP (μH)	Tolerance	NP(NS all shorted) (μH)max.	NP, NF-NS Sense: 1mA	Coil-Core Sense: 1mA	
VGT15EFD-200S3A6	8.0	$\pm 20\%$	0.2	2.6kVrms/1min	1.3kVrms/1min	NP:NF:NS1:NS2:NS3 =1:2.8:2.8:2.8:2.8

SHAPE & DIMENSIONS

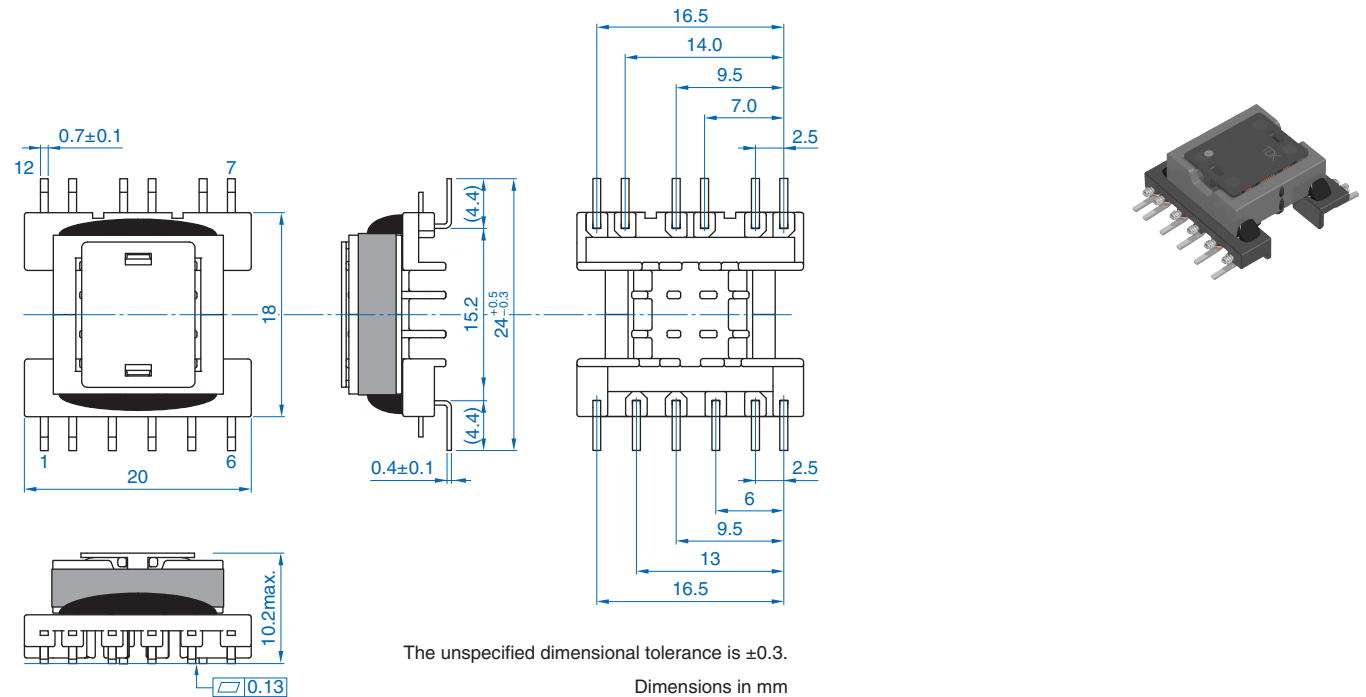

RECOMMENDED LAND PATTERN

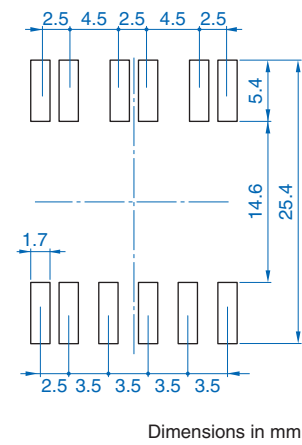

CIRCUIT DIAGRAM

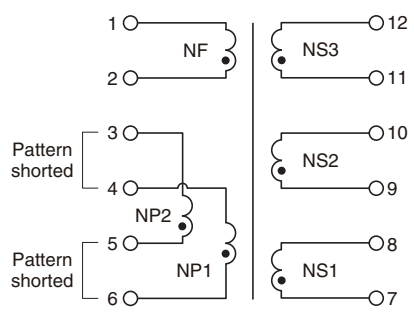

⚠ Please be sure to request delivery specifications that provide further details on the features and specifications of the products for proper and safe use. (4/9)
Please note that the contents may change without any prior notice due to reasons such as upgrading.

VGT15SEFD-200S1A4

ELECTRICAL CHARACTERISTICS

CHARACTERISTICS SPECIFICATION TABLE

Part No.	Inductance*		Leakage inductance* NP(NS all shorted) (μ H)max.	Withstanding voltage		Turn ratio
	NP (μ H)	Tolerance		NP, NF-NS Sense: 1mA	Coil-Core Sense: 1mA	
VGT15SEFD-200S1A4	10	$\pm 20\%$	0.2	2.6kVrms/1min	1.3kVrms/1min	NP:NF:NS =1:1.8:3.3

SHAPE & DIMENSIONS

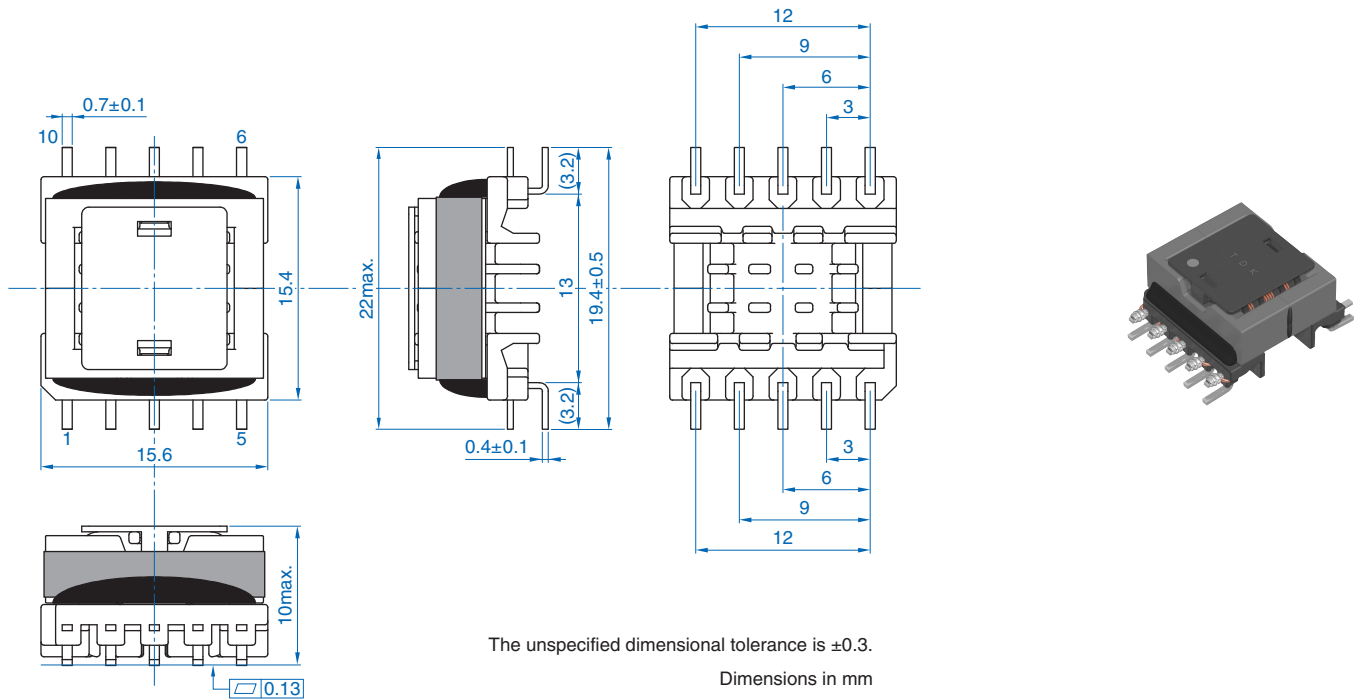

RECOMMENDED LAND PATTERN

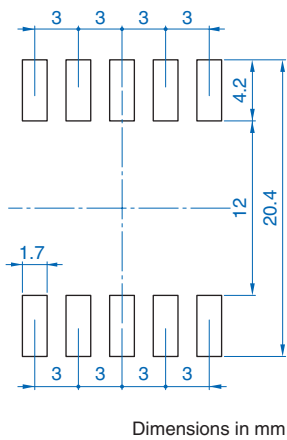

CIRCUIT DIAGRAM

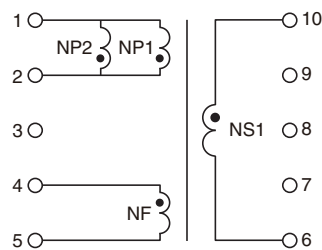

VGT15SEFD-250S4A7

ELECTRICAL CHARACTERISTICS

CHARACTERISTICS SPECIFICATION TABLE

Part No.	Inductance*		Leakage inductance*	Withstanding voltage		Turn ratio
	NP (μ H)	Tolerance	NP(NS all shorted) (μ H)max.	NP, NF-NS Sense: 1mA	Coil-Core Sense: 1mA	
VGT15SEFD-250S4A7	2.6	$\pm 20\%$	0.2	2.6kVrms/1min	1.3kVrms/1min	NP:NF:NS1:NS2:NS3:NS4 =1:3:3:3:3:3

SHAPE & DIMENSIONS

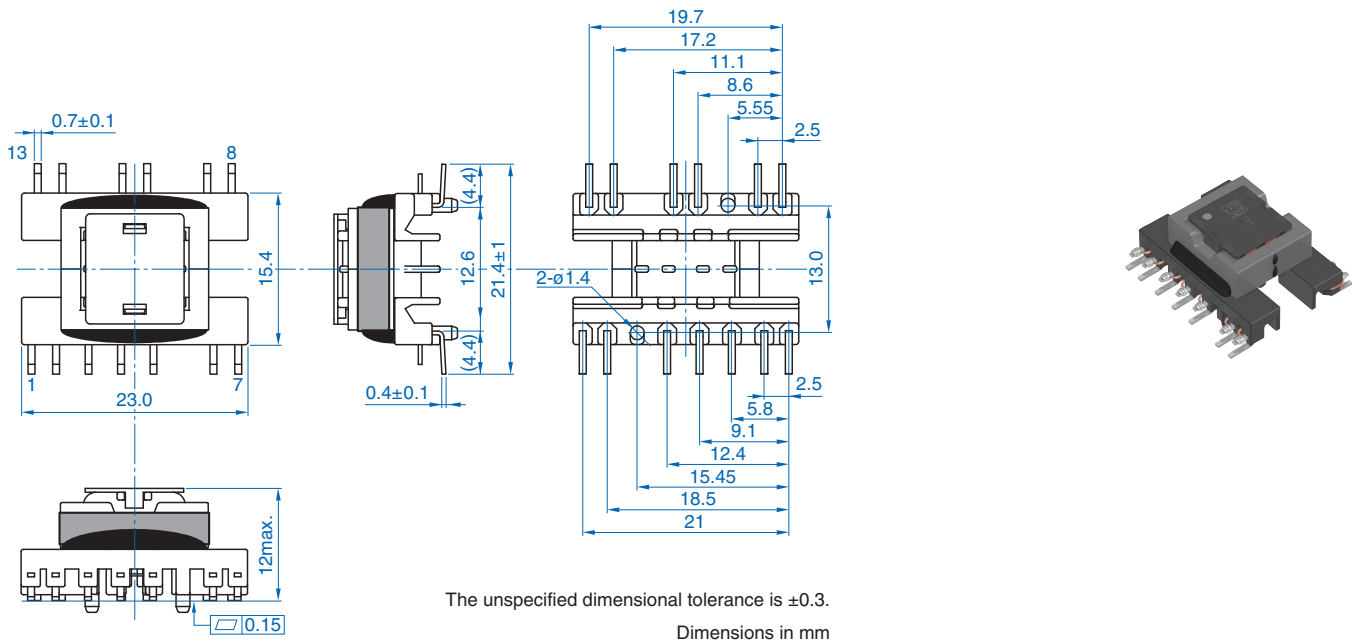

RECOMMENDED LAND PATTERN

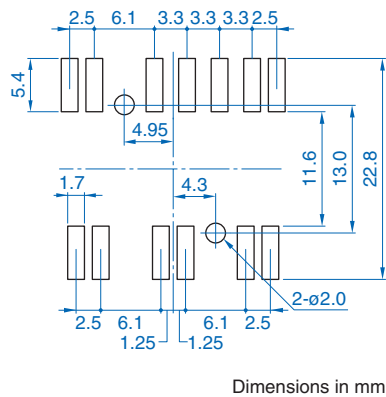

CIRCUIT DIAGRAM

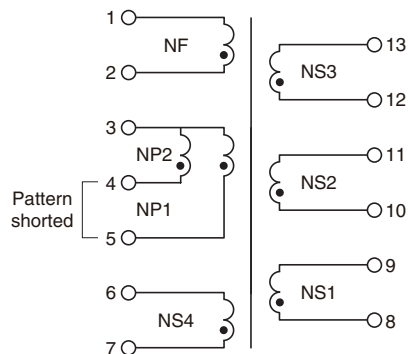

VGT22EPC-200S6A12

ELECTRICAL CHARACTERISTICS

CHARACTERISTICS SPECIFICATION TABLE

Part No.	Inductance*		Leakage inductance* NP(NS all shorted) (μ H)max.	Withstanding voltage		Turn ratio
	NP (μ H)	Tolerance		NP, NF-NS Sense: 1mA	Coil-Core Sense: 1mA	
VGT22EPC-200S6A12	2.5	$\pm 15\%$	0.3	2.6kVrms/1min	1.3kVrms/1min	NP:NS1-P:NS1-N:NS2-P:NS2-N: NS3-P:NS3-N:NS4-P:NS4-N =1:1.2:0.7:1.2:0.7:1.2:0.7:1.2:0.7

SHAPE & DIMENSIONS

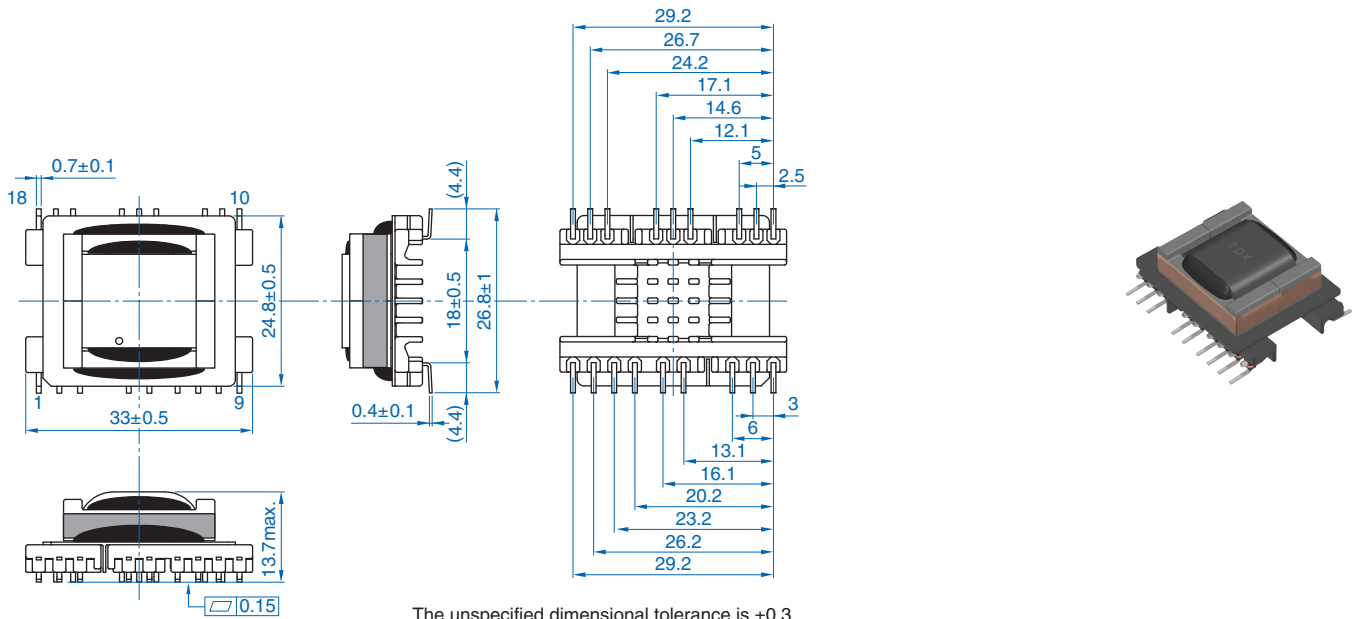

The unspecified dimensional tolerance is ± 0.3 .

Dimensions in mm

RECOMMENDED LAND PATTERN

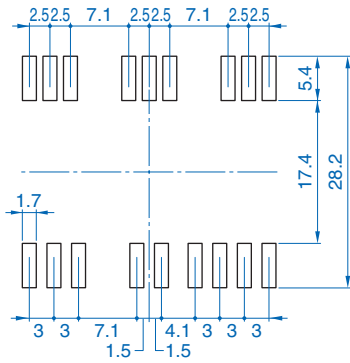

Dimensions in mm

CIRCUIT DIAGRAM

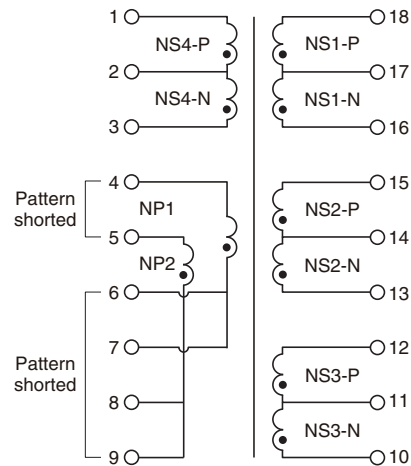

VGT series

RECOMMENDED REFLOW PROFILE

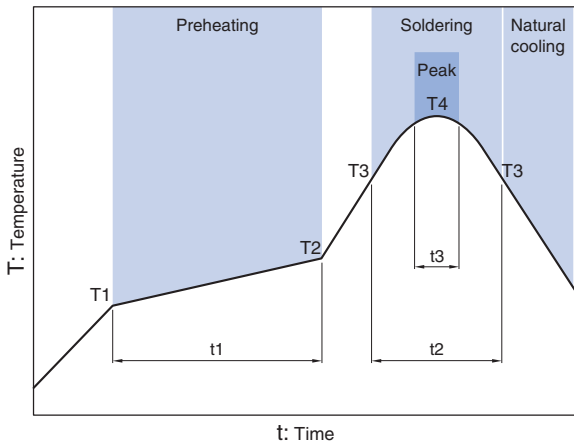

*When mounting the product, use our recommended reflow profile described above.

TEMPERATURE RANGE, INDIVIDUAL WEIGHT

Part No.	Temperature range		Individual weight (g)
	Operating temperature* (°C)	Storage temperature** (°C)	
VGT10SEE-200S2A5	-40 to +130	-40 to +130	1.9
VGT12EEM-200S1A4	-40 to +130	-40 to +130	1.9
VGT15EFD-200S3A6	-40 to +130	-40 to +130	4.1
VGT15SEFD-200S1A4	-40 to +130	-40 to +130	3.9
VGT15SEFD-250S4A7	-40 to +130	-40 to +130	4.6
VGT22EPC-200S6A12	-40 to +130	-40 to +130	10.8

* Operating temperature range includes self-temperature rise.

** The storage temperature range is for after the assembly.

PACKAGING STYLE

REEL DIMENSIONS, PACKAGE QUANTITY

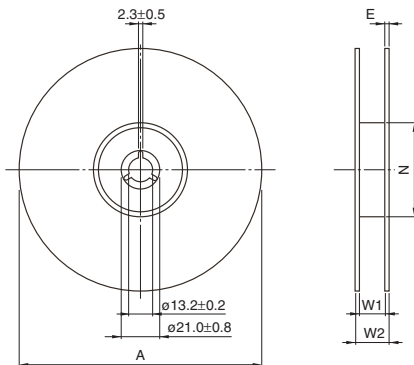

Dimensions in mm

Part No.	A	W1	W2	N	E	Package quantity (pcs/reel)
VGT10SEE-200S2A5	ø330	32.9	36.9	ø99.4	2	250
VGT12EEM-200S1A4	ø330	32.9	36.9	ø99.4	2	250
VGT15EFD-200S3A6	ø330	44.2	48.2	ø99.4	2	180
VGT15SEFD-200S1A4	ø330	44.2	48.2	ø99.4	2	200
VGT15SEFD-250S4A7	ø330	44.2	48.2	ø99.4	2	150
VGT22EPC-200S6A12	ø330	44.2	48.2	ø99.4	2	60

• These values are typical values.

TAPE DIMENSIONS

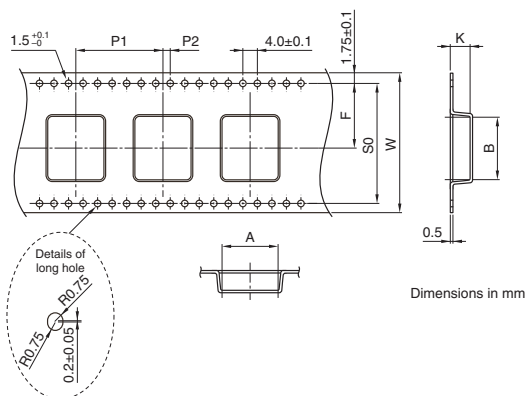

Dimensions in mm

Part No.	A	B	F	P1	P2	W	S0	K
VGT10SEE-200S2A5	13.4	18.9	14.2±0.1	20±0.1	2±0.1	32±0.3	28.4	11.4
VGT12EEM-200S1A4	13.7	16.6	14.2±0.1	20±0.1	2±0.1	32±0.3	28.4	10.4
VGT15EFD-200S3A6	20.4	24.8	20.2±0.1	28±0.1	2±0.1	44±0.3	40.4	10.5
VGT15SEFD-200S1A4	15.7	21.1	20.2±0.1	24±0.1	2±0.15	44±0.3	40.4	11.2
VGT15SEFD-250S4A7	22.6	23.8	20.2±0.1	28±0.1	2±0.1	44±0.3	40.4	13.0
VGT22EPC-200S6A12	33.3	28.3	20.2±0.1	44±0.15	2±0.1	44±0.3	40.4	14.1

An attention matter on use

Please read this specifications before using this product by all means.

An attention matter on security

I undertake use with this product, and it is paid attention enough, and please design an attention matter safely.

Attention on a design

- When you designs a base of an electric circuit.
Please use size of the hole or pad which we recommend.
- Magnetic flux to leak out occurs. Please confirm it about influence of magnetic flux beforehand.
There is fear to cause false movement of machinery.

Attention on the handling

- Please do not use it when you let a product drop.
The product produces possibility to lose a function.
- Please pay attention to the pin which had it pointed keenly. There is danger to injure.
- Please avoid the next place. The place that receives a drop of water, trash, the dust, foggy influence. The place where direct rays of the sun hits.
There is fear to cause false movement of machinery.
- Please prohibit safekeeping and use at the next place. Environment to be accompanied with gas corrosion, salt, acid, alkali.
There is fear to lose a function.
- When you carry the product on a base of an electric circuit.
Please do not use a metal tool. Because impossible power is added to a product.
There is fear to lose a function.

Attention on the handling

- I considered the next matter, and we designed a product.
Safe standard and power supply voltage and circuit drive condition, drive frequency and Duty ON-TIME.
By those conditions, we decided structure and the turns number.
Please avoid use in designed condition outside.
There are destruction of a circuit part and fear of ignition.
- This product considered a characteristic of a component and a self temperature rise, and it was made.
We select range of humidity as use temperature already.
Please avoid use by range more than this.
There are the damage and fear of ignition.
- Please avoid use in the environment next.
The environment that trash and the dust stick to a product. There is fear to cause a fire.
- The products listed on this specification sheet are intended for use in general electronic equipment and transportation equipment (AV equipment, telecommunications equipment, home appliances, amusement equipment, computer equipment, personal equipment, office equipment, measurement equipment, industrial robots, cars, electric trains, ships, etc.) under a normal operation and use condition.
- The products are not designed or warranted to meet the requirements of the applications listed below, whose performance and/or quality require a more stringent level of safety or reliability, or whose failure, malfunction or trouble could cause serious damage to society, person or property.
- If you intend to use the products in the applications listed below or if you have special requirements exceeding the range or conditions set forth in this catalog, please contact us.

- (1) Aerospace/aviation equipment
- (2) Medical equipment
- (3) Power-generation control equipment
- (4) Atomic energy-related equipment
- (5) Seabed equipment
- (6) Transportation control equipment
- (7) Public information-processing equipment

- (8) Military equipment
- (9) Electric heating apparatus, burning equipment
- (10) Disaster prevention/crime prevention equipment
- (11) Safety equipment
- (12) Other applications that are not considered general-purpose applications

When designing your equipment even for general-purpose applications, you are kindly requested to take into consideration securing protection circuit/device or providing backup circuits in your equipment.