

## OFF-line Primary Switch

### Features

- Switching frequency up to 300kHz
- Current mode control with adjustable limitation
- Soft start and shut-down control
- Automatic burst mode in standby condition ("Blue Angel" compliant)
- Undervoltage lockout with Hysteresis
- Integrated start-up current source
- Over-temperature protection
- Overload and short-circuit control
- Overvoltage protection
- In compliance with the 2002/95/EC European Directive

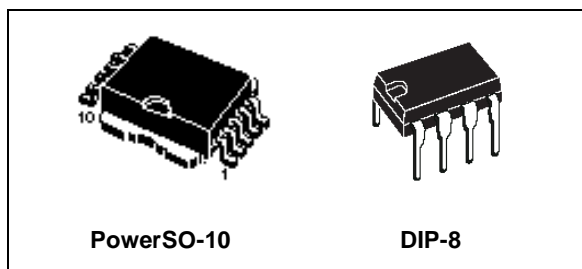

Typical applications cover offline power supplies with a secondary power capability ranging up to 30W in wide range input voltage, or 50W in single European voltage range and DIP-8 package and 40W in wide range input voltage, or 65W in single European voltage range and PowerSO-10 package, with the following benefits:

- Overload and short-circuit events controlled by feedback monitoring and delayed device reset;
- Efficient standby mode by enhanced pulse skipping.
- Integrated start-up current source is disabled during normal operation to reduce the input power.

### Description

The VIPer53E combines an enhanced current mode PWM controller with a high voltage MDMesh Power MOSFET in the same package.

### Block diagram

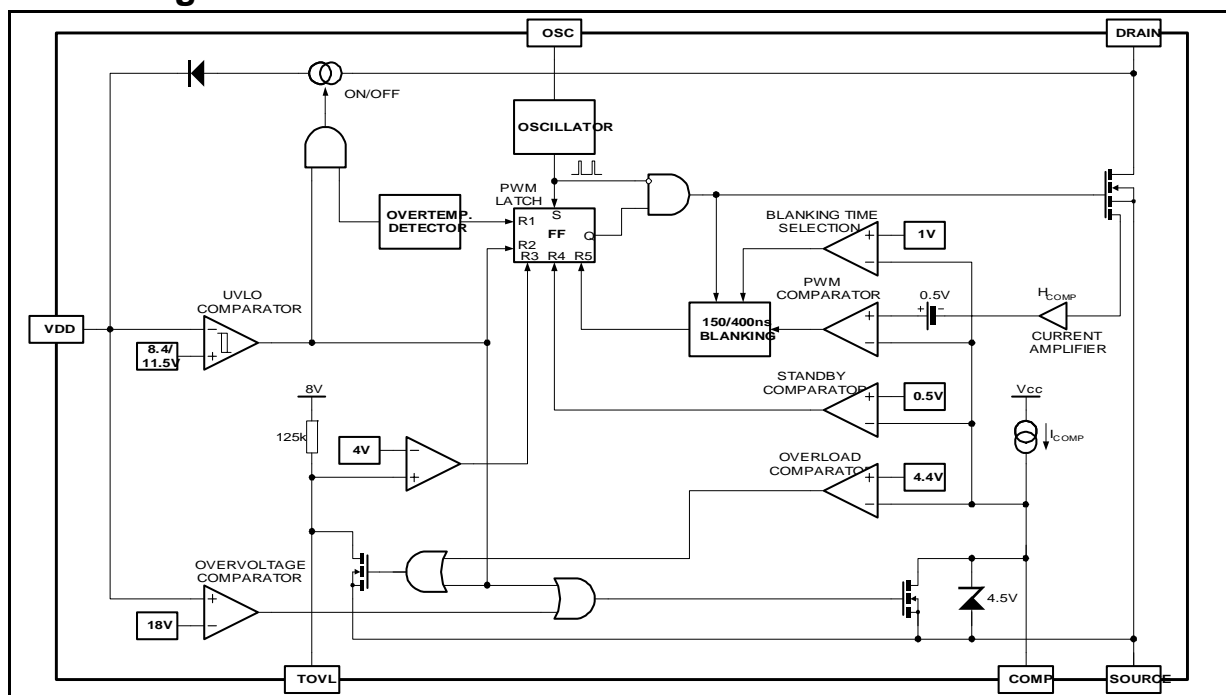

## Contents

<b>1</b>	<b>Electrical data</b> .....	<b>3</b>
1.1	Maximum rating .....	3
1.2	Thermal data .....	3
<b>2</b>	<b>Electrical characteristics</b> .....	<b>4</b>
<b>3</b>	<b>Pin connections and function</b> .....	<b>7</b>
<b>4</b>	<b>Rectangular U-I Output characteristics</b> .....	<b>8</b>
<b>5</b>	<b>Secondary Feedback Configuration Example</b> .....	<b>9</b>
<b>6</b>	<b>Current Mode Topology</b> .....	<b>10</b>
<b>7</b>	<b>Standby Mode</b> .....	<b>11</b>
<b>8</b>	<b>High Voltage Start-up Current Source</b> .....	<b>13</b>
<b>9</b>	<b>Short-Circuit and Overload Protection</b> .....	<b>15</b>
<b>10</b>	<b>Regulation Loop Stability</b> .....	<b>16</b>
<b>11</b>	<b>Special Recommendations</b> .....	<b>18</b>
<b>12</b>	<b>Software Implementation</b> .....	<b>19</b>
<b>13</b>	<b>Operation pictures</b> .....	<b>20</b>
<b>14</b>	<b>Mechanical Data</b> .....	<b>26</b>
<b>15</b>	<b>Order codes</b> .....	<b>29</b>
<b>16</b>	<b>Revision history</b> .....	<b>30</b>

# 1 Electrical data

## 1.1 Maximum rating

Stressing the device above the rating listed in the “Absolute Maximum Ratings” table may cause permanent damage to the device. These are stress ratings only and operation of the device at these or any other conditions above those indicated in the Operating sections of this specification is not implied. Exposure to Absolute Maximum Rating conditions for extended periods may affect device reliability. Refer also to the STMicroelectronics SURE Program and other relevant quality documents.

**Table 1. Absolute maximum rating**

Symbol	Parameter	Value	Unit
$V_{DS}$	Continuous Drain Source Voltage ( $T_J = 25 \dots 125^\circ\text{C}$ ) <sup>(1)</sup>	-0.3 ... 620	V
$I_D$	Continuous Drain Current	Internally limited	A
$V_{DD}$	Supply Voltage	0 ... 19	V
$V_{OSC}$	OSC Input Voltage Range	0 ... $V_{DD}$	V
$I_{COMP}$ $I_{TOVL}$	COMP and TOVL Input Current Range <sup>(1)</sup>	-2 ... 2	mA
$V_{ESD}$	Electrostatic Discharge:		
	Machine Model ( $R = 0\Omega$ ; $C = 200\text{pF}$ ) Charged Device Model	200 1.5	V kV
$T_J$	Junction Operating Temperature	Internally limited	$^\circ\text{C}$
$T_C$	Case Operating Temperature	-40 to 150	$^\circ\text{C}$
$T_{STG}$	Storage Temperature	-55 to 150	$^\circ\text{C}$

1. In order to improve the ruggedness of the device versus eventual drain overvoltages, a resistance of 1k $\Omega$  should be inserted in series with the TOVL pin.\

## 1.2 Thermal data

**Table 2. Thermal data**

Symbol	Parameter		PowerSO-10 <sup>(1)</sup>	DIP-8 <sup>(2)</sup>	Unit
$R_{thJC}$	Thermal Resistance Junction-case	Max	2	20	$^\circ\text{C/W}$
$R_{thJA}$	Thermal Resistance Ambient-case	Max	60	80	$^\circ\text{C/W}$

1. When mounted on a standard single-sided FR4 board with 50mm<sup>2</sup> of Cu (at least 35 mm thick) connected to the DRAIN pin.  
2. When mounted on a standard single-sided FR4 board with 50mm<sup>2</sup> of Cu (at least 35 mm thick) connected to the device tab.

## 2 Electrical characteristics

$T_J = 25^\circ\text{C}$ ,  $V_{DD} = 13\text{V}$ , unless otherwise specified

**Table 3. Power section**

Symbol	Parameter	Test conditions	Min.	Typ.	Max.	Unit
$BV_{DSS}$	Drain-Source Voltage	$I_D = 1\text{mA}$ ; $V_{COMP} = 0\text{V}$	620			V
$I_{DSS}$	Off State Drain Current	$V_{DS} = 500\text{V}$ ; $V_{COMP} = 0\text{V}$ ; $T_J = 125^\circ\text{C}$			150	$\mu\text{A}$
$R_{DS(on)}$	Static Drain-Source On State Resistance	$I_D = 1\text{A}$ ; $V_{COMP} = 4.5\text{V}$ ; $V_{TOVL} = 0\text{V}$ $T_J = 25^\circ\text{C}$ $T_J = 100^\circ\text{C}$		0.9	1 1.7	$\Omega$ $\Omega$
$t_{fv}$	Fall Time	$I_D = 0.2\text{A}$ ; $V_{IN} = 300\text{V}^{(1)}$		100		ns
$t_{rv}$	Rise Time	$I_D = 1\text{A}$ ; $V_{IN} = 300\text{V}^{(1)}$		50		ns
$C_{OSS}$	Drain Capacitance	$V_{DS} = 25\text{V}$		170		pF
$C_{Eon}$	Effective Output Capacitance	$200\text{V} < V_{DSon} < 400\text{V}^{(2)}$		60		pF

1. On clamped inductive load
2. This parameter can be used to compute the energy dissipated at turn on  $E_{ton}$  according to the initial drain to source voltage  $V_{DSon}$  and the following formula:

$$E_{ton} = \frac{1}{2} \cdot C_{Eon} \cdot 300^2 \cdot \left(\frac{V_{DSon}}{300}\right)^{1.5}$$

**Table 4. Oscillator Section**

Symbol	Parameter	Test Conditions	Min.	Typ.	Max.	Unit
$F_{OSC1}$	Oscillator Frequency Initial Accuracy	$R_T = 8\text{k}\Omega$ ; $C_T = 2.2\text{nF}$ <i>Figure 15 on page 23</i>	95	100	105	kHz
$F_{OSC2}$	Oscillator Frequency Total Variation	$R_T = 8\text{k}\Omega$ ; $C_T = 2.2\text{nF}$ <i>Figure 17 on page 24</i> $V_{DD} = V_{DDon} \dots V_{DDovp}$ ; $T_J = 0 \dots 100^\circ\text{C}$	93	100	107	kHz
$V_{OSChi}$	Oscillator Peak Voltage			9		V
$V_{OSClo}$	Oscillator Valley Voltage			4		V

**Table 5. Supply Section**

Symbol	Parameter	Test Conditions	Min.	Typ.	Max.	Unit
$V_{DSstart}$	Drain Voltage Starting Threshold	$V_{DD} = 5V; I_{DD} = 0mA$		34	50	V
$I_{DDch1}$	Startup Charging Current	$V_{DD} = 0 \dots 5V; V_{DS} = 100V$ <i>Figure 9 on page 22</i>		-12		mA
$I_{DDch2}$	Startup Charging Current	$V_{DD} = 10V; V_{DS} = 100V$ <i>Figure 9.</i>		-2		mA
$I_{DDchoff}$	Startup Charging Current in Thermal Shutdown	$V_{DD} = 5V; V_{DS} = 100V$ <i>Figure 11.</i> $T_J > T_{SD} - T_{HYST}$	0			mA
$I_{DD0}$	Operating Supply Current Not Switching	$F_{sw} = 0kHz; V_{COMP} = 0V$		8	11	mA
$I_{DD1}$	Operating Supply Current Switching	$F_{sw} = 100kHz$		9		mA
$V_{DDoff}$	$V_{DD}$ Undervoltage Shutdown Threshold	<i>Figure 9 on page 22</i>	7.5	8.4	9.3	V
$V_{DDon}$	$V_{DD}$ Startup Threshold	<i>Figure 9.</i>	10.2	11.5	12.8	V
$V_{DDhyst}$	$V_{DD}$ Threshold Hysteresis	<i>Figure 9.</i>	2.6	3.1		V
$V_{DDovp}$	$V_{DD}$ Overvoltage Shutdown Threshold	<i>Figure 9.</i>	17	18	19	V

**Table 6. Pwm Comparator Section**

Symbol	Parameter	Test Conditions	Min.	Typ.	Max.	Unit
$H_{COMP}$	$\Delta V_{COMP} / \Delta I_{DPEAK}$	$V_{COMP} = 1 \dots 4V$ <i>Figure 14.</i> $di_D/dt = 0$	1.7	2	2.3	V/A
$V_{COMPos}$	$V_{COMP}$ Offset	$di_D/dt = 0$ <i>Figure 14.</i>		0.5		V
$I_{Dim}$	Peak Drain Current Limitation	$I_{COMP} = 0mA; V_{TOVL} = 0V$ <i>Figure 14.</i> $di_D/dt = 0$	1.7	2	2.3	A
$I_{Dmax}$	Drain Current Capability	$V_{COMP} = V_{COMPovl}; V_{TOVL} = 0V$ $di_D/dt = 0$	1.6	1.9	2.3	A
$t_d$	Current Sense Delay to Turn-Off	$I_D = 1A$		250		ns
$V_{COMPbl}$	$V_{COMP}$ Blanking Time Change Threshold	<i>Figure 10 on page 22</i>		1		V
$t_{b1}$	Blanking Time	$V_{COMP} < V_{COMPBL}$ <i>Figure 10.</i>	300	400	500	ns
$t_{b2}$	Blanking Time	$V_{COMP} > V_{COMPBL}$ <i>Figure 10.</i>	100	150	200	ns
$t_{ONmin1}$	Minimum On Time	$V_{COMP} < V_{COMPBL}$	450	600	750	ns

**Table 6. Pwm Comparator Section**

Symbol	Parameter	Test Conditions	Min.	Typ.	Max.	Unit
$t_{ONmin2}$	Minimum On Time	$V_{COMP} > V_{COMPBL}$	250	350	450	ns
$V_{COMPoff}$	$V_{COMP}$ Shutdown Threshold	<a href="#">Figure 13 on page 23</a>		0.5		V
$V_{COMPHi}$	$V_{COMP}$ High Level	$I_{COMP}=0mA$ <sup>(1)</sup>		4.5		V
$I_{COMP}$	COMP Pull Up Current	$V_{COMP}= 2.5V$		0.6		mA

1. In order to ensure a correct stability of the internal current source, a 10nF capacitor (minimum value 8nF) should always be present on the COMP pin.

**Table 7. Overload Protection Section**

Symbol	Parameter	Test Conditions	Min.	Typ.	Max.	Unit
$V_{COMPovl}$	$V_{COMP}$ Overload Threshold	$I_{TOVL} = 0mA$ <a href="#">Figure 7 on page 20</a> <sup>(1)</sup>		4.35		V
$V_{DIFFovl}$	$V_{COMPHi}$ to $V_{COMPovl}$ Voltage Difference	$V_{DD} = V_{DDoff} \dots V_{DDreg}$ ; $I_{TOVL} = 0mA$ <a href="#">Figure 7.</a> <sup>(1)</sup>	50	150	250	mV
$V_{OVLth}$	$V_{TOVL}$ Overload Threshold	<a href="#">Figure 7.</a>		4		V
$t_{OVL}$	Overload Delay	$C_{OVL} = 100nF$ <a href="#">Figure 7.</a>		8		ms

1.  $V_{COMPovl}$  is always lower than  $V_{COMPHi}$

**Table 8. Over temperature Protection Section**

Symbol	Parameter	Test Conditions	Min.	Typ.	Max.	Unit
$T_{SD}$	Thermal Shutdown Temperature	<a href="#">Figure 11 on page 22</a>	140	160		°C
$T_{HYST}$	Thermal Shutdown Hysteresis	<a href="#">Figure 11 on page 22</a>		40		°C

**Table 9. Typical Output Power Capability**

Type	European (195 - 265Vac)	US / Wide range (85 - 265Vac)
VIPer53EDIP-E	50W	30W
VIPer53ESP-E	65W	40W

### 3 Pin connections and function

Figure 1. Pin connection (top view)



Figure 2. Current and voltage conventions

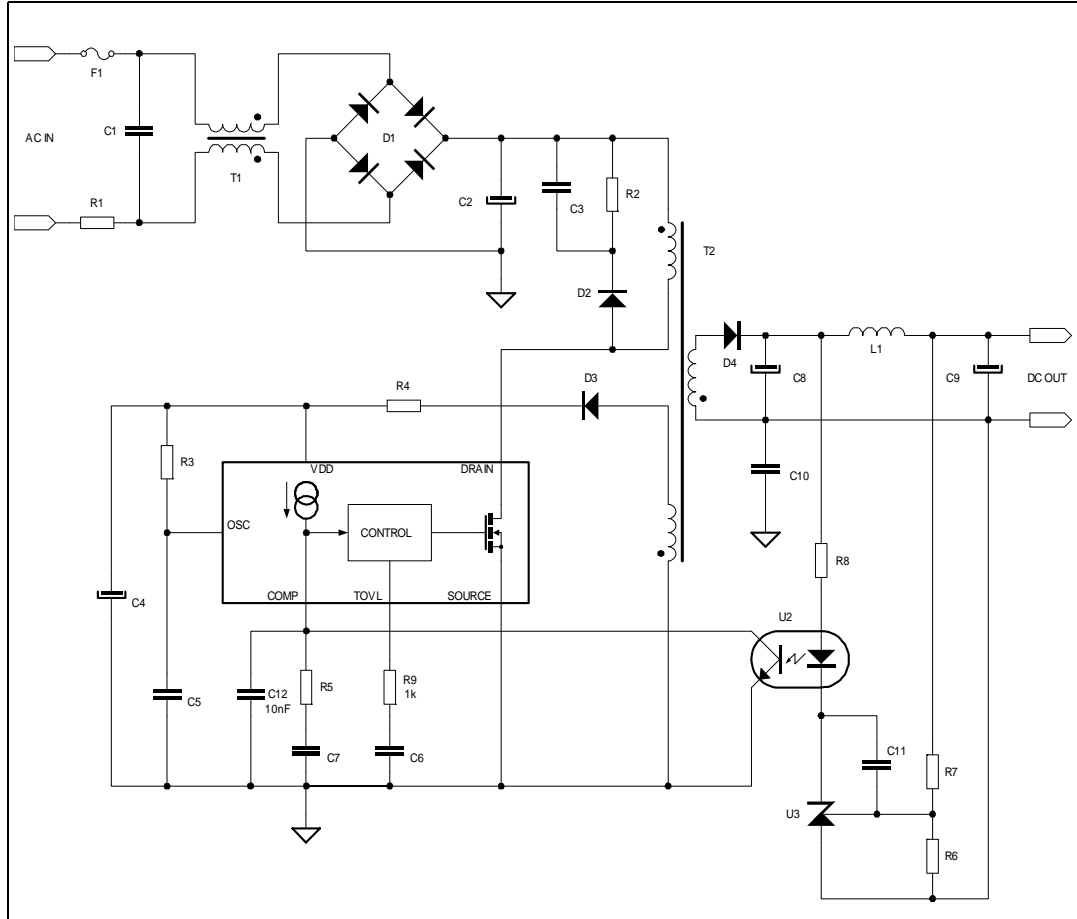

Table 10. Pin function

Pin Name	Pin Function
V <sub>DD</sub>	Power supply of the control circuits. Also provides the charging current of the external capacitor during start-up. The functions of this pin are managed by four threshold voltages: - V <sub>DDon</sub> : Voltage value at which the device starts switching (Typically 11.5 V). - V <sub>DDoff</sub> : Voltage value at which the device stops switching (Typically 8.4 V). - V <sub>DDovp</sub> : Triggering voltage of the overvoltage protection (Trimmed to 18 V).
SOURCE	Power MOSFET source and circuit ground reference.
DRAIN	Power MOSFET drain. Also used by the internal high voltage current source during the start-up phase, to charge the external V <sub>DD</sub> capacitor.
COMP	Allows the setting of the dynamic characteristic of the converter through an external passive network. The useful voltage range extends from 0.5V to 4.5V. The Power MOSFET is always off below 0.5V, and the overload protection is triggered if the voltage exceeds 4.35V. This action is delayed by the timing capacitor connected to the TOVL pin.
TOVL	Allows the connection of an external capacitor for delaying the overload protection, which is triggered by a voltage on the COMP pin higher than 4.4V.
OSC	Allows the setting of the switching frequency through an external Rt-Ct network.

# 4 Rectangular U-I Output characteristics

Figure 3. Off Line Power Supply With Optocoupler Feedback





## 5 Secondary Feedback Configuration Example

The secondary feedback is implemented through an optocoupler driven by a programmable zener diode (TL431 type) as shown in [Figure 3 on page 8](#)

The optocoupler is connected in parallel with the compensation network on the COMP pin which delivers a constant biasing current of 0.6mA to the optotransistor. This current does not depend on the compensation voltage, and so it does not depend on the output load either. Consequently, the gain of the optocoupler ensures a constant biasing of the TL431 device (U3), which is responsible for secondary regulation. If the optocoupler gain is sufficiently low, no additional components are required to a minimum current biasing of U3. Additionally, the low biasing current protects the optocoupler from premature failure.

The constant current biasing can be used to simplify the secondary circuit: instead of a TL431, a simple zener and resistance network in series with the optocoupler diode can insure a good secondary regulation. Current flowing in this branch remains constant just as it does by using a TL431, so typical load regulation of 1% can be achieved from zero to full output current with this simple configuration.

Since the dynamic characteristics of the converter are set on the secondary side through components associated to U3, the compensation network has only a role of gain stabilization for the optocoupler, and its value can be freely chosen. R5 can be set to a fixed value of 2.2k $\Omega$ , offering the possibility of using C7 as a soft start capacitor: When starting up the converter, the VIPer53E device delivers a constant current of 0.6mA on the COMP pin, creating a constant voltage of 1.3V in R5 and a rising slope across C7. This voltage shape, together with the operating range of 0.5V to 4.5V provides a soft startup of the converter. The rising speed of the output voltage can be set through the value of C7. The C4 and C6 values must be adjusted accordingly in order to ensure a correct startup.

## 6 Current Mode Topology

The VIPer53E implements the conventional current mode control method for regulating the output voltage. This kind of feedback includes two nested regulation loops:

The inner loop controls the peak primary current cycle by cycle. When the Power MOSFET output transistor is on, the inductor current (primary side of the transformer) is monitored with a SenseFET technique and converted into a voltage. When  $V_S$  reaches  $V_{COMP}$ , the power switch is turned off. This structure is completely integrated as shown on the Block Diagram of [Figure on page 1](#), with the current amplifier, the PWM comparator, the blanking time function and the PWM latch. The following formula gives the peak current in the Power MOSFET according to the compensation voltage:

$$I_{Dpeak} = \frac{V_{COMP} - V_{COMP0s}}{H_{COMP}}$$

The outer loop defines the level at which the inner loop regulates peak current in the power switch. For this purpose,  $V_{COMP}$  is driven by the feedback network (TL431 through an optocoupler in secondary feedback configuration, see [Figure 3 on page 8](#)) and is sets accordingly the peak drain current for each switching cycle.

As the inner loop regulates the peak primary current in the primary side of the transformer, all input voltage changes are compensated for before impacting the output voltage. This results in an improved line regulation, instantaneous correction to line changes, and better stability for the voltage regulation loop.

Current mode topology also provides a good converter start-up control. The compensation voltage can be controlled to increase slowly during the start-up phase, so the peak primary current will follow this soft voltage slope to provide a smooth output voltage rise, without any overshoot. The simpler voltage mode structure which only controls the duty cycle, leads generally to high current at start-up with the risk of transformer saturation.

An integrated blanking filter inhibits the PWM comparator output for a short time after the integrated Power MOSFET is switched on. This function prevents anomalous or premature termination of the switching pulse in the case of current spikes caused by primary side transformer capacitance or secondary side rectifier reverse recovery time when working in continuous mode.

## 7 Standby Mode

The device offers a special feature to address the low load condition. The corresponding function described hereafter consists of reducing the switching frequency by going into burst mode, with the following benefits:

- It reduces the switching losses, thus providing low consumption on the mains lines. The device is compliant with “Blue Angel” and other similar standards, requiring less than 0.5 W of input power when in standby.
- It allows the regulation of the output voltage, even if the load corresponds to a duty cycle that the device is not able to generate because of the internal blanking time, and associated minimum turn on.

For this purpose, a comparator monitors the COMP pin voltage, and maintains the PWM latch and the Power MOSFET in the Off state as long as  $V_{COMP}$  remains below 0.5V (See Block Diagram on page 2). If the output load requires a duty cycle below the one defined by the minimum turn on of the device, the  $V_{COMP}$  net decreases its voltage until it reaches this 0.5V threshold ( $V_{COMPoff}$ ). The Power MOSFET can be completely Off for some cycles, and resumes normal operation as soon as  $V_{COMP}$  is higher than 0.5V. The output voltage is regulated in burst mode. The corresponding ripple is not higher than the nominal one at full load.

In addition, the minimum turn on time which defines the frontier between normal operation and burst mode changes according to  $V_{COMP}$  value. Below 1.0V ( $V_{COMPbl}$ ), the blanking time increases to 400ns, whereas for higher voltages, it is 150ns [Figure 10 on page 22](#) The minimum turn on times resulting from these values are respectively 600 ns and 350 ns, when taking into account internal propagation time. This brutal change induces an hysteresis between normal operation and burst mode as shown on [Figure 10 on page 22](#)

When the output power decreases, the system reaches point 2 where  $V_{COMP}$  equals  $V_{COMPbl}$ . The minimum turn-on time passes immediately from 350ns to 600ns, exceeding the effective turn-on time that should be needed at this output power level. Therefore the regulation loop will quickly drive  $V_{COMP}$  to  $V_{COMPoff}$  (Point 3) in order to pass into burst mode and to control the output voltage. The corresponding hysteresis can be seen on the switching frequency which passes from  $F_{SWnom}$  which is the normal switching frequency set by the components connected to the OSC pin and to FSWstby. Note: This frequency is actually an equivalent number of switching pulses per second, rather than a fixed switching frequency since the device is working in burst mode.

As long as the power remains below  $P_{RST}$  the output of the regulation loop remains stuck at  $V_{COMPsd}$  and the converter works in burst mode. Its “density” increases (i.e. the number of missing cycles decreases) as the power approaches  $P_{RST}$  and finally resumes normal operation at point 1. The hysteresis cannot be seen on the switching frequency, but it can be seen in the sudden surge of the COMP pin voltage from point 3 to point 1 at that power level.

The power points value  $P_{RST}$  and  $P_{STBY}$  are defined by the following formulas:

$$P_{RST} = \frac{1}{2} \cdot F_{SWnom} \cdot (tb_1 + td)^2 \cdot V^2_{IN} \cdot \frac{1}{Lp}$$

$$P_{STBY} = \frac{1}{2} \cdot F_{SWnom} \cdot Ip^2(V_{COMPbl}) \cdot Lp$$

Where  $I_p(V_{COMPbI2})$  is the peak Power MOSFET current corresponding to a compensation voltage of  $V_{COMPbI}$  (1V). Note: The power point PSTBY where the converter is going into burst mode does not depend on the input voltage.

The standby frequency  $F_{SWstby}$  is given by:

$$P_{SWstby} = \frac{P_{STBY}}{P_{RST}} \cdot F_{SWnom}$$

The ratio between the nominal and standby switching frequencies can be as high as 4, depending on the  $L_p$  value and input voltage.

**Figure 4. Standby Mode Implementation**



## 8 High Voltage Start-up Current Source

An integrated high voltage current source provides a bias current from the DRAIN pin during the start-up phase. This current is partially absorbed by internal control circuits in standby mode with reduced consumption, and also supplies the external capacitor connected to the  $V_{DD}$  pin. As soon as the voltage on this pin reaches the high voltage threshold  $V_{DDon}$  of the UVLO logic, the device turns into active mode and starts switching. The start-up current generator is switched off, and the converter should normally provide the needed current on the  $V_{DD}$  pin through the auxiliary winding of the transformer, as shown on [Figure 3 on page 8](#).

The external capacitor  $C_{VDD}$  on the  $V_{DD}$  pin must be sized according to the time needed by the converter to start-up, when the device starts switching. This time  $t_{ss}$  depends on many parameters, including transformer design, output capacitors, soft start feature, and compensation network implemented on the COMP pin and possible secondary feedback circuit. The following formula can be used for defining the minimum capacitor needed:

$$C_{VDD} > \frac{I_{DD1} \cdot t_{ss}}{V_{DDhyst}}$$

[Figure 9 on page 22](#) shows a typical start-up event.  $V_{DD}$  starts from 0V with a charging current  $I_{DDch1}$  at about 9 mA. When about  $V_{DDoff}$  is reached, the charging current is reduced down to  $I_{DDch2}$  which is about 0.6mA. This lower current leads to a slope change on the  $V_{DD}$  rise. Device starts switching for  $V_{DD}$  equal to  $V_{DDon}$ , and the auxiliary winding delivers some energy to  $V_{DD}$  capacitor after the start-up time  $t_{ss}$ .

The charging current change at  $V_{DDoff}$  allows a fast complete start-up time  $t_{SDU}$ , and maintains a low restart duty cycle. This is especially useful for short circuits and overloads conditions, as described in the following section.

Figure 5. Start-up Waveforms

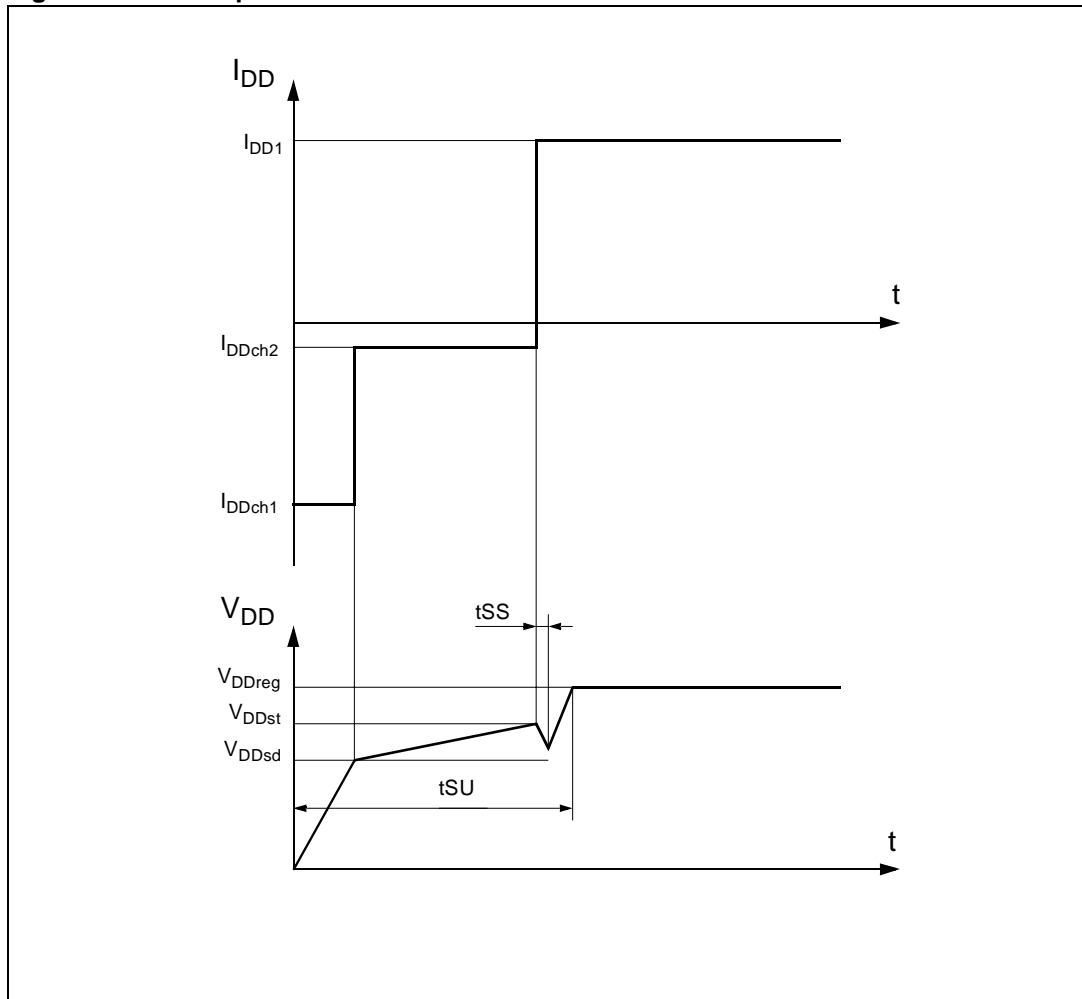

## 9 Short-Circuit and Overload Protection

A  $V_{\text{COMPovl}}$  threshold of about 4.4V has been implemented on the COMP pin. When  $V_{\text{COMP}}$  goes above this level, the capacitor connected on the TOVL pin begins to charge. When reaching typically  $V_{\text{OVLth}}$  (4V), the internal MOSFET driver is disabled and the device stops switching. This state is latched because of to the regulation loop which maintains the COMP pin voltage above the  $V_{\text{COMPovl}}$  threshold. Since the  $V_{\text{DD}}$  pin does not receive any more energy from the auxiliary winding, its voltage drops down until it reaches  $V_{\text{DDoff}}$  and the device is reset, recharging the  $V_{\text{DD}}$  capacitor for a new restart cycle. Note: If  $V_{\text{COMP}}$  drops below the  $V_{\text{COMPovl}}$  threshold for any reason during the  $V_{\text{DD}}$  drop, the device resumes switching immediately.

The device enters an endless restart sequence if the overload or short circuit condition is maintained. The restart duty cycle  $D_{\text{RST}}$  is defined as the time ratio for which the device tries to restart, thus delivering its full power capability to the output. In order to keep the whole converter in a safe state during this event,  $D_{\text{RST}}$  must be kept as low as possible, without compromising the real start-up of the converter. A typical value of about 10% is generally sufficient. For this purpose, both  $V_{\text{DD}}$  and TOVL capacitors can be used to satisfy the following conditions:

$$C_{\text{OVL}} > 12.5 \cdot 10^{-6} \cdot t_{\text{ss}}$$

$$C_{\text{VDD}} > 8 \cdot 10^4 \cdot \left( \frac{1}{D_{\text{RST}}} - 1 \right) \cdot \frac{C_{\text{OVL}} \cdot I_{\text{DDch2}}}{V_{\text{DDhyst}}}$$

Refer to the previous start-up section for the definition of  $t_{\text{ss}}$ , and  $C_{\text{VDD}}$  must also be checked against the limit given in this section. The maximum value of the two calculus will be adopted.

All this behavior can be observed on [Figure 2 on page 7](#). In [Figure 7 on page 20](#) the value of the drain current  $I_{\text{d}}$  for  $V_{\text{COMP}} = V_{\text{COMPovl}}$  is shown. The corresponding parameter  $I_{\text{Dmax}}$  is the drain current to take into account for design purposes. Since  $I_{\text{Dmax}}$  represents the maximum value for which the overload protection is not triggered, it defines the power capability of the power supply.

## 10 Regulation Loop Stability

The complete converter open loop transfer function can be built from both power cell and the feedback network transfer functions. A theoretical example can be seen in [Figure 11 on page 22](#) for a discontinuous mode flyback loaded by a simple resistor.

A typical schematic corresponding to this situation can be seen on [Figure 3 on page 8](#). The transfer function of the power cell is represented as  $G(s)$  in [Figure 11 on page 22](#). It exhibits a pole which depends on the output load and on the output capacitor value. As the load of a converter may change, two curves are shown for two different values of output resistance value,  $R_{L1}$  and  $R_{L2}$ . A zero at higher frequency values then appears, due to the output capacitor ESR. Note: The overall transfer function does not depend on the input voltage because of the current mode control. A typical regulation loop is shown on [Figure 3 on page 8](#) and has a fixed behavior represented by  $F(s)$  on [Figure 11 on page 22](#). A double zero due to the  $R_1$ - $C_1$  network on the COMP pin and to the integrator built around the TL431 and  $R_2$ - $C_2$  is set at the same value as the maximum load  $R_{L2}$  pole.

The total transfer function is shown as  $F(s) \cdot G(s)$  at the bottom of [Figure 11 on page 22](#). For maximum load (plain line), the load pole begins exactly where the zeros of the COMP pin and the TL431 stop, and this results in a first order decreasing slope until it reaches the zero of the output capacitor ESR. The point where the complete transfer function has a unity gain is known as the regulation bandwidth and has a double interest:

- The higher it is, the faster the reaction will be to an eventual load change, and the smaller the output voltage change will be.
- The phase shift in the complete system at this point has to be less than  $135^\circ$  to ensure good stability. Generally, a first-order slope gives  $90^\circ$  of phase shift, and a second-order gives  $180^\circ$ .

In [Figure 3 on page 8](#), the unity gain is reached in a first order slope, so the stability is ensured.

The dynamic load regulation is improved by increasing the regulation bandwidth, but some limitations have to be respected:

1. As the transfer function above zero due the ESR capacitor is not reliable (the ESR itself is not well specified, and other parasitic effects may take place), the bandwidth should always be lower than the minimum of FC and ESR zero
2. As the highest bandwidth is obtained with the highest output power (plain line with  $R_{L2}$  load in [Figure 3](#), the above criteria will be checked for this condition and allows the value of  $R_4$  if  $R_1$  is set to a fixed value (e.g.,  $2.2k\Omega$ ).

As the highest bandwidth is obtained with the highest output power (Plain line with  $R_{L2}$  load in [Figure 3](#)), the above criteria will be checked for this condition and allows to define the value of  $R_4$ , if  $R_1$  is set fixed ( $2.2k\Omega$ , for instance). The following formula can be derived:

$$R_4 = \sqrt{\frac{P_{MAX}}{P_{OUT2}}} \cdot \frac{G_O \cdot R_1}{F_{BW2} \cdot R_{L2} \cdot C_{OUT}}$$

$$\text{with: } P_{OUT2} = \frac{V_{OUT}^2}{R_{L2}}$$

$$\text{and: } P_{MAX} = \frac{1}{2} \cdot L_P \cdot I_{LIM}^2 \cdot F_{SW}$$

Go is the current transfer ratio of the optocoupler.



The lowest load gives another condition for stability: The frequency  $F_{BW1}$  must not encounter the third order slope generated by the load pole, the R1-C1 network on the COMP pin and the R2-C2 network at the level of the TL431 on secondary side. This condition can be met by adjusting both  $C_1$  and  $C_2$  values:

$$C_1 > \frac{R_{L1} \cdot C_{OUT}}{6.3 \cdot \frac{G_O}{R_4} \cdot R_1^2} \cdot \sqrt{\frac{P_{OUT1}}{P_{MAX}}}$$

$$C_2 > \frac{R_{L1} \cdot C_{OUT}}{6.3 \cdot \frac{G_O}{R_4} \cdot R_1 \cdot R_2} \cdot \sqrt{\frac{P_{OUT1}}{P_{MAX}}}$$

with:  $P_{OUT1} = \frac{V_{OUT}^2}{R_{L1}}$

The above formula gives a minimum value for  $C_1$ . It can be then increased to provide a natural soft start function as this capacitor is charged by the current  $I_{COMP}$  at start-up.

## 11 Special Recommendations

10nF capacitor (minimum value: 8nF) should always be connected to the COMP pin to ensure correct stability of the internal current source [Figure 12 on page 22](#).

In order to improve the ruggedness of the device versus eventual drain overvoltages, a resistance of 1k $\Omega$  should be inserted in series with the TOVL pin, as shown on [Figure 12 on page 22](#)

*Note:* This resistance does not impact the overload delay, as its value is negligible prior to the internal pull-up resistance (about 125k $\Omega$ ).

## 12 Software Implementation

All the above considerations and some others are included in ST design software which provides all of the needed components around the VIPer device for specified output configurations, and is available on [www.st.com](http://www.st.com).

# 13 Operation pictures

Figure 6. Rise and Fall time



Figure 7. Overloaded Event



Figure 8. Complete Converter Transfer Function



Figure 9. Start-up  $V_{DD}$  current



Figure 10. Blanking Time

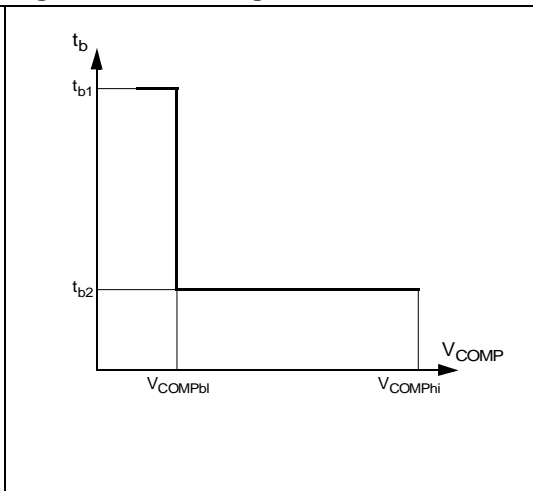

Figure 11. Thermal Shutdown

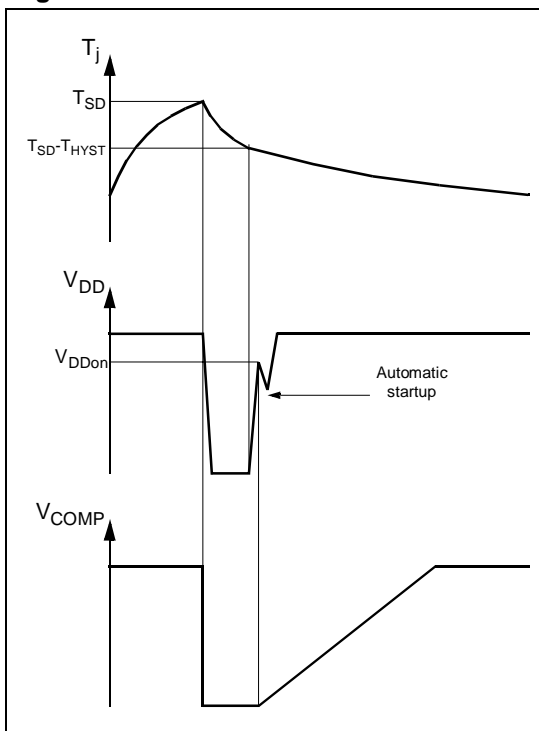

Figure 12. Overvoltage Event

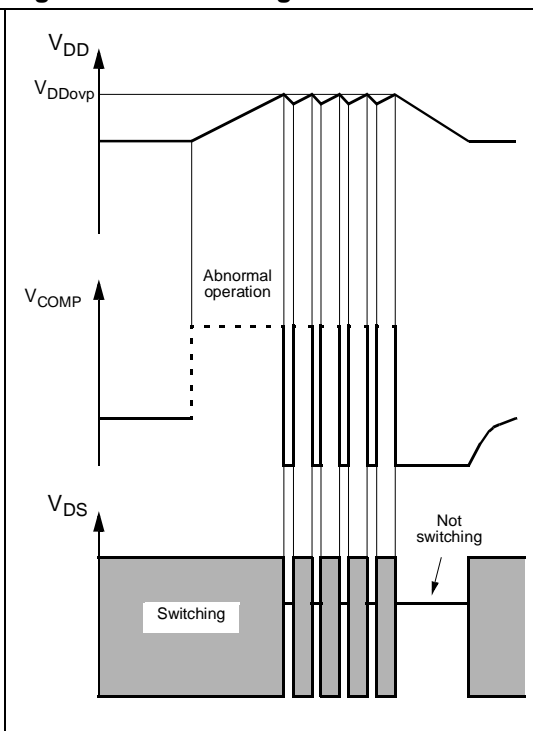

Figure 13. Shutdown Action



Figure 14. Comp Pin Gain and Offset



Figure 15. Oscillator Schematic



The switching frequency settings shown on the graphic here below is valid within the following boundaries:

$$R_T > 2k\Omega$$

$$F_{SW} = 300kHz$$

**Figure 16. Oscillator Settings**

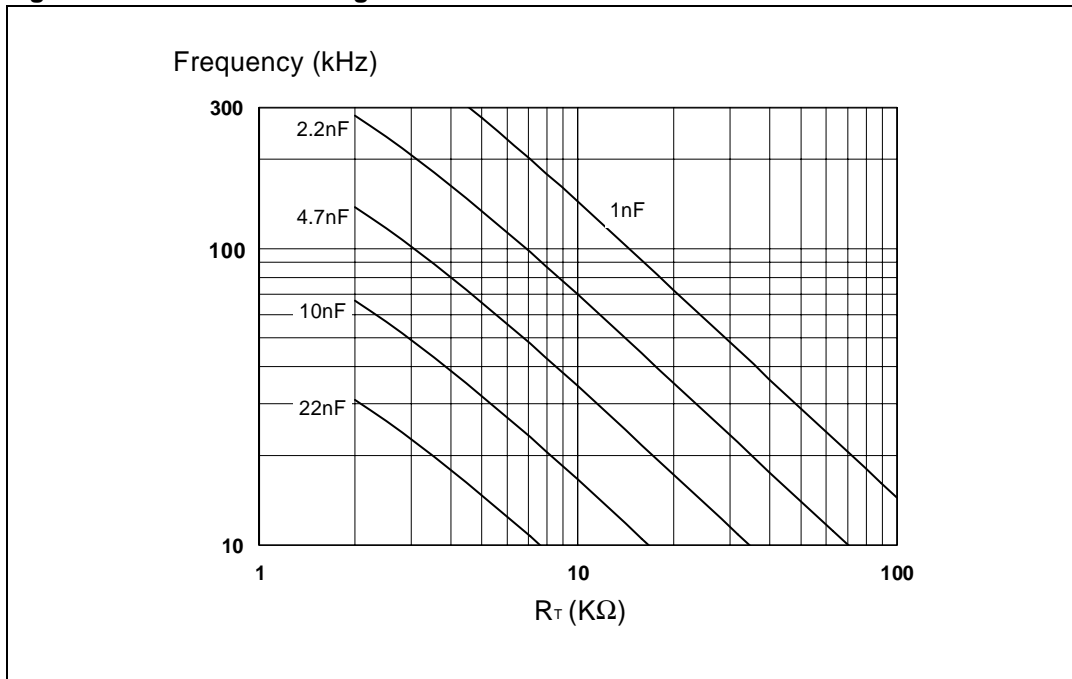

**Figure 17. Typical Frequency Variation vs. Junction Temperature**

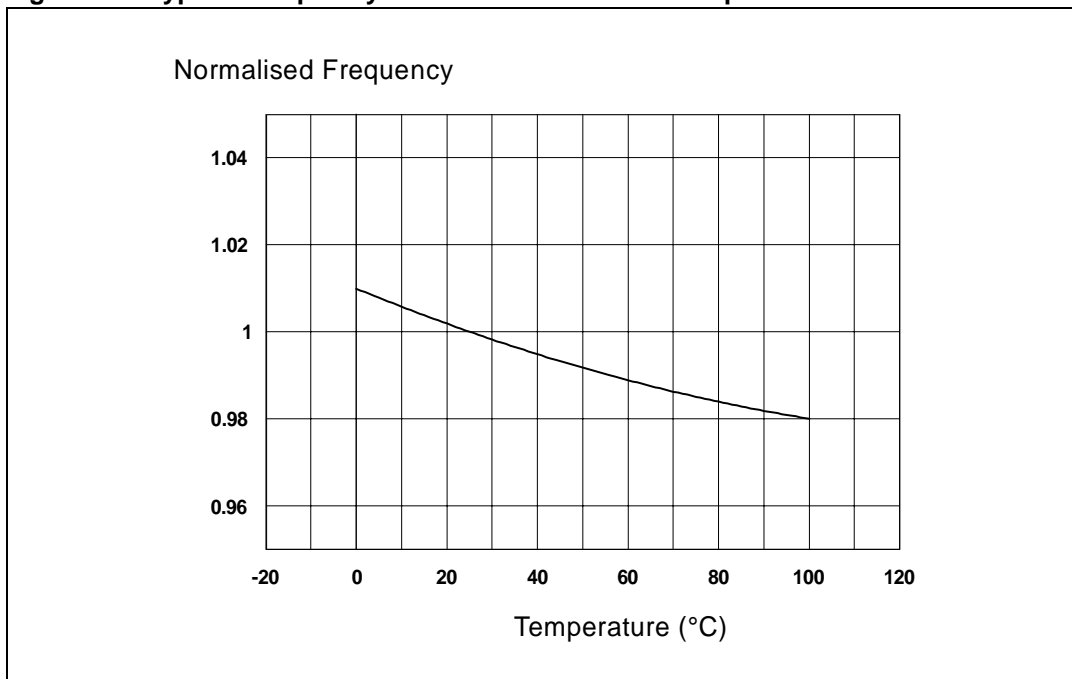



Figure 18. Typical Current Limitation vs. Junction Temperature



## 14 Mechanical Data

In order to meet environmental requirements, ST offers these devices in ECOPACK® packages. These packages have a Lead-free second level interconnect. The category of second Level Interconnect is marked on the package and on the inner box label, in compliance with JEDEC Standard JESD97. The maximum ratings related to soldering conditions are also marked on the inner box label. ECOPACK is an ST trademark. ECOPACK specifications are available at: [www.st.com](http://www.st.com).

Table 11. DIP8 Mechanical Data

Dimensions			
Ref.	Databook (mm)		
	Nom.	Min	Max
A			5.33
A1	0.38		
A2	2.92	3.30	4.95
b	0.36	0.46	0.56
b2	1.14	1.52	1.78
c	0.20	0.25	0.36
D	9.02	9.27	10.16
E	7.62	7.87	8.26
E1	6.10	6.35	7.11
e		2.54	
eA		7.62	
eB			10.92
L	2.92	3.30	3.81
Package Weight	Gr. 470		

Figure 19. Package Dimensions



Table 12. PowerSO-10 Mechanical Data

Dimensions			
Ref.	Databook (mm)		
	Nom.	Min	Max
A	3.35		3.65
A1	0.00		0.10
B	0.40		0.60
c	0.35		0.55
D	9.40		9.60
D1	7.40		7.60
E	9.30		9.50
E1	7.20		7.40
E2	7.20		7.60
E3	6.10		6.35
E4	5.90		6.10
e		1.27	
F	1.25		1.35
H	13.80		14.40
h		0.50	
L	1.20		1.80
q		1.70	
$\alpha$	0°		8°

Figure 20. Package Dimensions

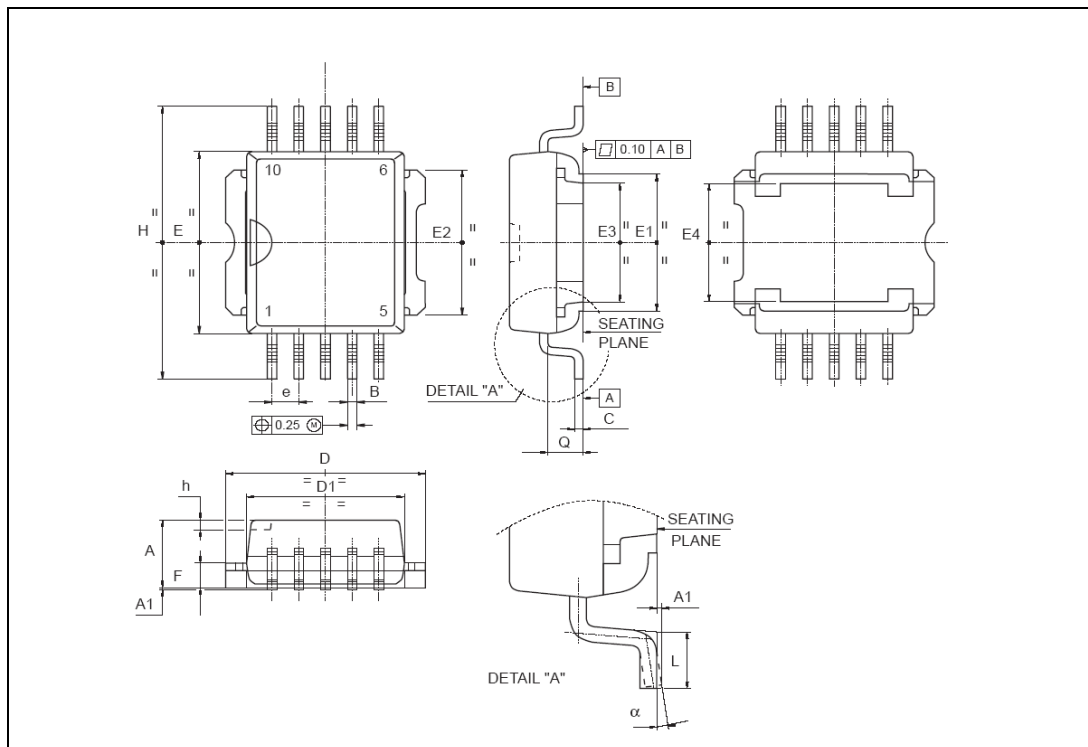

## 15 Order codes

**Table 13. Order codes**

Part Number	Package	Shipment
VIPer53ESPTR - E	PowerSO-10	Tape and reel
VIPer53ESP - E	PowerSO-10	Tube
VIPer53EDIP - E	DIP-8	Tube

## 16 Revision history

**Table 14. Document revision history**

Date	Revision	Changes
12-Jan-2006	1	Initial release.

Information furnished is believed to be accurate and reliable. However, STMicroelectronics assumes no responsibility for the consequences of use of such information nor for any infringement of patents or other rights of third parties which may result from its use. No license is granted by implication or otherwise under any patent or patent rights of STMicroelectronics. Specifications mentioned in this publication are subject to change without notice. This publication supersedes and replaces all information previously supplied. STMicroelectronics products are not authorized for use as critical components in life support devices or systems without express written approval of STMicroelectronics.

The ST logo is a registered trademark of STMicroelectronics.  
All other names are the property of their respective owners

© 2006 STMicroelectronics - All rights reserved

STMicroelectronics group of companies

Australia - Belgium - Brazil - Canada - China - Czech Republic - Finland - France - Germany - Hong Kong - India - Israel - Italy - Japan -  
Malaysia - Malta - Morocco - Singapore - Spain - Sweden - Switzerland - United Kingdom - United States of America

[www.st.com](http://www.st.com)