



Description

VK1622S is a LCD controller with 32x8 memory mapping driver. It is especially designed for low power operation, extra timer function, and simple control interface and so on. These make VK1622S most suitable for the MCU application.

Features

- ◇ Operating voltage 2.7V-5.5V
- ◇ Clock sources - built-in 32768Hz oscillator or external clock
- ◇ Simple control interface with multiple functions
- ◇ Timer function output
- ◇ Two kinds of fixed buzzer frequency output
- ◇ Externally adjustable LCD voltage pin
- ◇ 32 segment×8 common LCD drivers with memory mapping
- ◇ 1/8 LCD duty
- ◇ 1/4 LCD bias with built-in R-type driver
- ◇ Externally adjustable LCD bias driver pins

Block Diagram

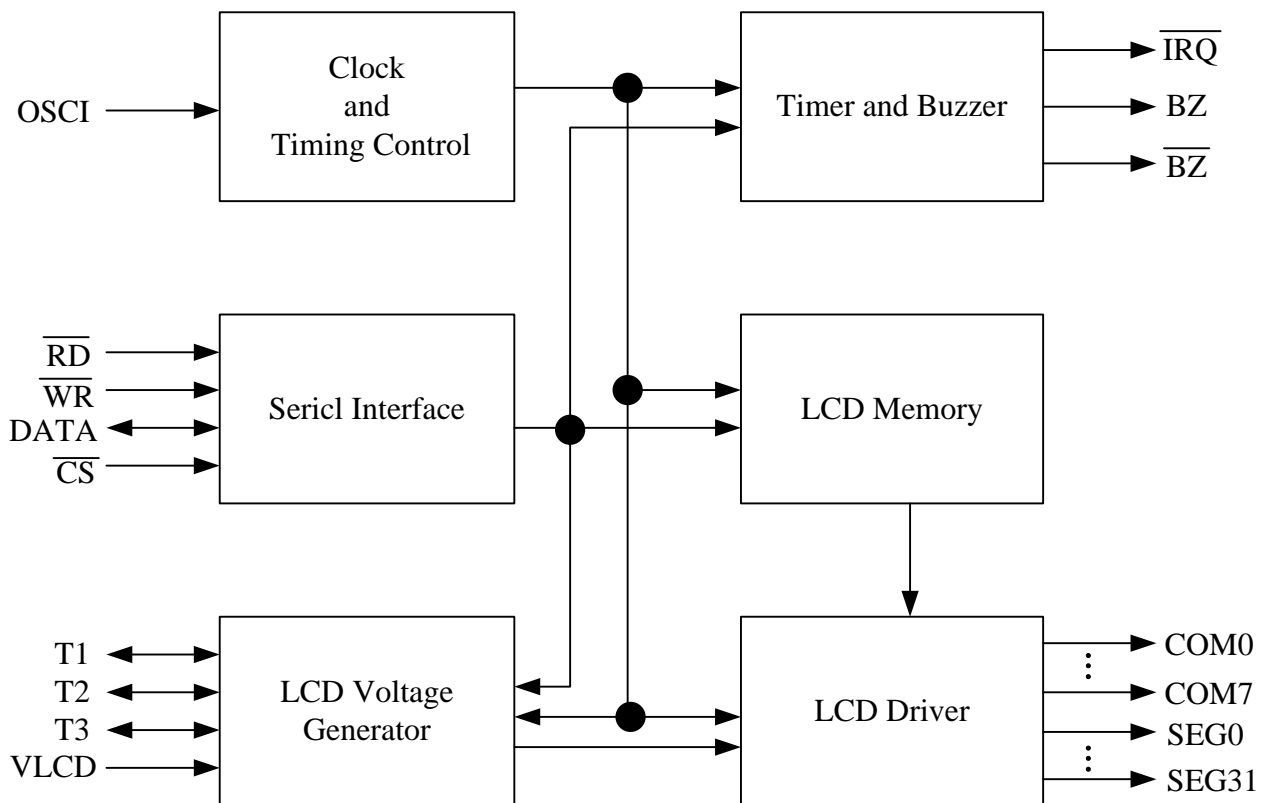

Application Circuit



VK1622S 32*8 液晶驅動 IC

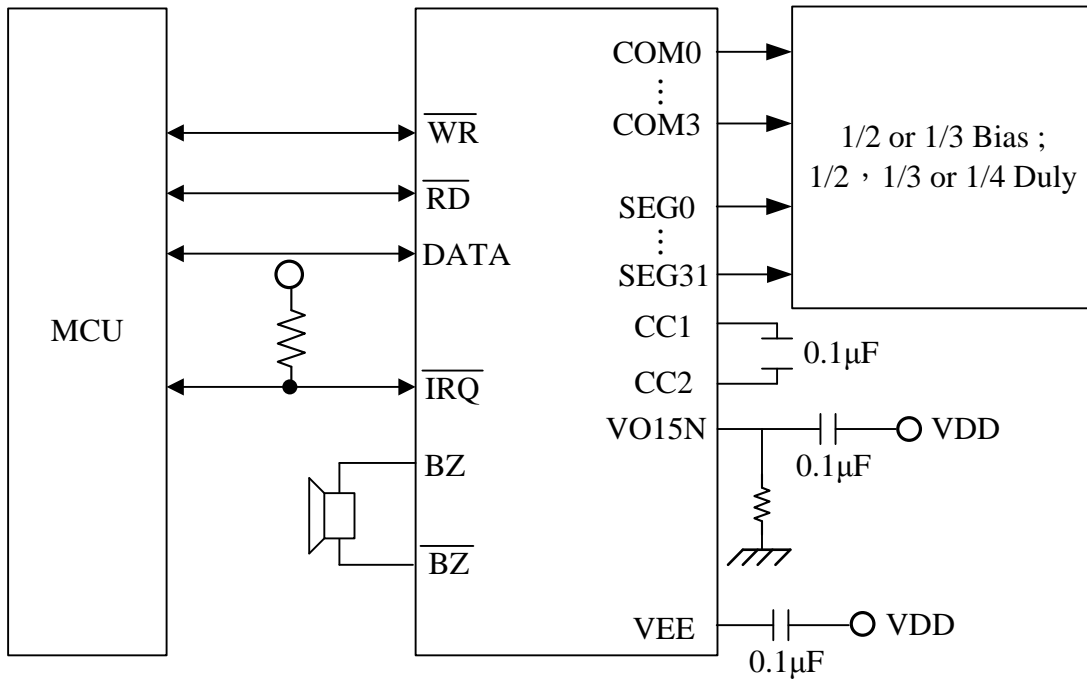

Note : The 0.1uF capacitor between VDD and GND must be placed closely to VK1622S



. Pin Description

Pin Name	type	Description
OSCI	I	Input of external clock
GND	G	Ground
VDD	P	Positive power
\overline{RD}	I	Interface read control with low active, built-in pull high resistor
\overline{WR}	I	Interface write control with low active, built-in pull high resistor
DATA	I/O	Interface data input and output with pull high resistor
\overline{CS}	I	Interface chip select control with low active, built-in pull high resistor
$\overline{BZ}/\overline{BZ}$	O	Buzzer frequency output
\overline{IRQ}	O	Timer output with NMOS open drain
VLCD	I	Voltage input of LCD
T1-T3	I/O	Resistor connection for LCD bias circuit, built-in serial resistor to GND
COM0-COM7	O	LCD common
SEG0-SEG31	O	LCD segment

. AC / DC Characteristics

Absolutely max. ratings

Characteristics	Symbol	Rating	Unit
Supply Voltage	Vdd	5.5	V
Input Voltage	Vin	Vss-0.3 to Vdd+0.3	V
Operating Temperature	Top	-25°C - +75°C	°C
Storage Temperature	Tsto	-50°C - +125°C	°C

D.C. Characteristics

Characteristics	Symbol	Test Condition and Vdd Voltage	Min.	Typ.	Max.	unit
Operating voltage	VDD		2.7	3	5.5	V
Operating current 1	I _{OP1}	Built-in oscillator on, LCD on, No load	3V	80	210	uA
			5V	135	415	
Operating current 2	I _{OP2}	Built-in oscillator on, LCD off, No load	3V	8	30	uA
			5V	20	55	
Stand-by current	I _{stb}	Oscillator off, System halt, LCD off, No load	3V	1	8	uA
			5V	2	16	
Input Low Voltage	V _{IL1}	at $\overline{RD}/\overline{WR}/\overline{DATA}/\overline{CS}$	3V	0	0.6	V
			5V	0	1.0	
Input High Voltage	V _{IH1}	at $\overline{RD}/\overline{WR}/\overline{DATA}/\overline{CS}$	3V	2.4	3	V
			5V	4.0	5.0	
Output Source Current	I _{OH1}	VOH=2.7 at DATA	3V	-200	-450	uA
		VOH=4.5 at DATA	5V	-250	-500	
Output Sink Current	I _{OL1}	VOL=0.3V at DATA	3V	200	450	uA
		VOL=0.5V at DATA	5V	250	500	
Segment output 'H' Current	I _{SOH}	VOH=2.7 at SEG0-SEG31	3V	-6	-13	uA
		VOH=4.5 at SEG0-SEG31	5V	-20	-40	



VK1622S 32*8 液晶驅動 IC

Segment output 'L' Current	IS _{OL}	VOL=0.3V at SEG0-SEG31	3V	15	30		uA
		VOL=0.5V at SEG0-SEG31	5V	70	150		
Common output 'H' Current	IC _{OH}	VOH=2.7 at COM0-COM7	3V	-15	-30		uA
		VOH=4.5 at COM0-COM7	5V	-45	-90		
Common output 'L' Current	IC _{OL}	VOL=0.3V at COM0-COM7	3V	15	40		uA
		VOL=0.5V at COM0-COM7	5V	100	200		
Pull-High Resistor	R _{PH}	at \overline{RD} / \overline{WR} / DATA/ \overline{CS}	3V	100	200	300	k Ω
			5V	50	100	150	

A.C. Characteristics

Characteristics	Symbol	Test Condition	Min.	Typ.	Max.	unit	
System clock 1	f _{SYS1}	Built-in oscillator	3V	22	32	40	KHz
			5V	24	32	40	
System clock 2	f _{SYS2}	External clock		32		KHz	
Interface Reset Pulse	T _{CS}	$\overline{CS} = 'L'$		250		ns	
Interface Write Pulse	T _{WR}	$\overline{WR} = 'L'$ at Vdd = 3.0V	3.34			us	
Interface Read Pulse	T _{RD}	$\overline{RD} = 'L'$ at Vdd = 3.0V	6.67			us	
Interface DATA Frequency	FD _{WR}	Write at Clock duty 50% at Vdd = 3.0V			150	KHz	
	FD _{RD}	Read at Clock duty 50% at Vdd = 3.0V			75	KHz	
LCD frame frequency	F _{LCD1}	32768Hz Crystal oscillator , LCD at 1/8 duty		64		HZ	



Function Description

1. Interface Control function

Function	Pre-code	Post-code	
		Address	Value
System	100	B7B6B5B4—B3B2B1B0—x	
Read	110	A5A4A3A2A1A0	V0V1V2V3
Write	101	A5A4A3A2A1A0	V0V1V2V3
Combination	101	A5A4A3A2A1A0	V0V1V2V3

System Function	Post-code B7B6B5B4—B3B2B1B0—x	Description	Reset
System On	0000—0001—x	Enable system oscillator ON	
System Off	0000—0000—x	Disable system oscillator OFF & LCD circuit OFF	Yes
Select built-in oscillator	0001—10xx—x	System clock use built-in 32K oscillator	Yes
Select external clock	0001—11xx—x	System clock use external clock	
Timer output enable	100x—1xxx—x	Enable \overline{IRQ} output	
Timer output disable	100x—0xxx—x	Disable \overline{IRQ} output	Yes
Timer1 on	0000—0110—x	Timer1 on	
Timer2 on	0000—0111—x	Timer2 on	
Timer1 off	0000—0100—x	Timer1 off	Yes
Timer2 off	0000—0101—x	Timer2 off	Yes
Clear Timer1	0000—1101—x	Clear Timer1 Counter	
Clear Timer2	0000—1111—x	Clear Timer2 Counter	
Timer frequency	101x—0000—x	Timer1 frequency=1Hz, \overline{IRQ} =0 after 4s	
	101x—0001—x	Timer1 frequency=2Hz, \overline{IRQ} =0 after 2s	
	101x—0010—x	Timer1 frequency=4Hz, \overline{IRQ} =0 after 1s	
	101x—0011—x	Timer1 frequency=8Hz, \overline{IRQ} =0 after 1/2s	
	101x—0100—x	Timer1 frequency=16Hz, \overline{IRQ} =0 after 1/4s	
	101x—0101—x	Timer1 frequency=32Hz, \overline{IRQ} =0 after 1/8s	
	101x—0110—x	Timer1 frequency=64Hz, \overline{IRQ} =0 after 1/16s	
	101x—0111—x	Timer1 frequency=128Hz, \overline{IRQ} =0 after 1/32s	Yes
Buzzer frequency And enable	010x—xxxx—x	Enable 4Khz buzzer frequency	
	0110—xxxx—x	Enable 2Khz buzzer frequency	



System Function	Post-code B7B6B5B4—B3B2B1B0—x	Description	Reset
Buzzer disable	0000—1000—x	Disable Buzzer output	Yes
LCD off	0000—0010—x	LCD circuit OFF	Yes
LCD on	0000—0011—x	LCD circuit ON	
Reserved	1110—0000—x	Don't use	
Reserved	1110—0011—x	Don't use	Yes

* Timer output is decided by the selection of the 8 kinds of Timer1 and divided by 4 at Timer2.

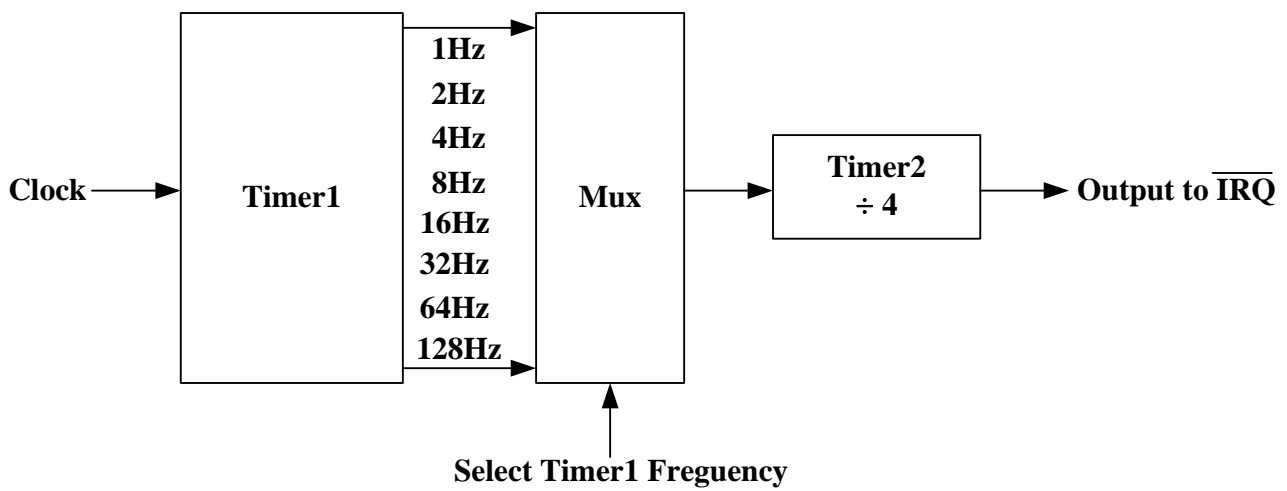



2 LCD Memory Mapping

Segment	A5A4A3A2A1A0	Common			
		Bit0	Bit1	Bit2	Bit3
SEG0	000000	COM0	COM1	COM2	COM3
	000001	COM4	COM5	COM6	COM7
SEG1	000010	COM0	COM1	COM2	COM3
	000011	COM4	COM5	COM6	COM7
SEG2	000100	COM0	COM1	COM2	COM3
	000101	COM4	COM5	COM6	COM7
SEG3	000110	COM0	COM1	COM2	COM3
	000111	COM4	COM5	COM6	COM7
SEG4	001000	COM0	COM1	COM2	COM3
	001001	COM4	COM5	COM6	COM7
SEG5	001010	COM0	COM1	COM2	COM3
	001011	COM4	COM5	COM6	COM7
•	•	•	•	•	•
•	•	•	•	•	•
•	•	•	•	•	•
•	•	•	•	•	•
•	•	•	•	•	•
SEG26	110100	COM0	COM1	COM2	COM3
	110101	COM4	COM5	COM6	COM7
SEG27	110110	COM0	COM1	COM2	COM3
	110111	COM4	COM5	COM6	COM7
SEG28	111000	COM0	COM1	COM2	COM3
	111001	COM4	COM5	COM6	COM7
SEG29	111010	COM0	COM1	COM2	COM3
	111011	COM4	COM5	COM6	COM7
SEG30	111100	COM0	COM1	COM2	COM3
	111101	COM4	COM5	COM6	COM7
SEG31	111110	COM0	COM1	COM2	COM3
	111111	COM4	COM5	COM6	COM7



3 Interface Control Timing

A.-1 Read Function(Pre-Code:110)

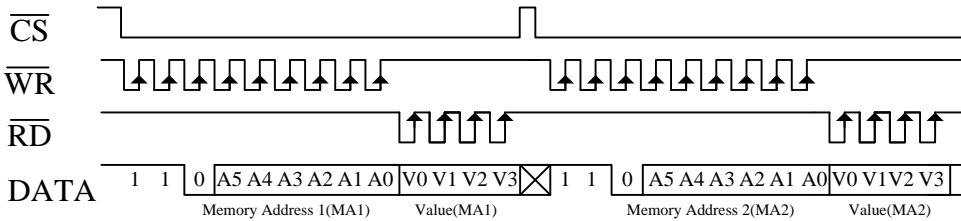

A.-2 Read Function(Successive Address Reading)

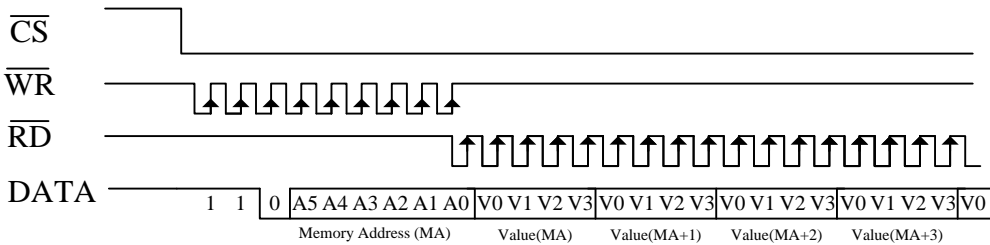

B.-1 Write Function (Pre-Code:101)

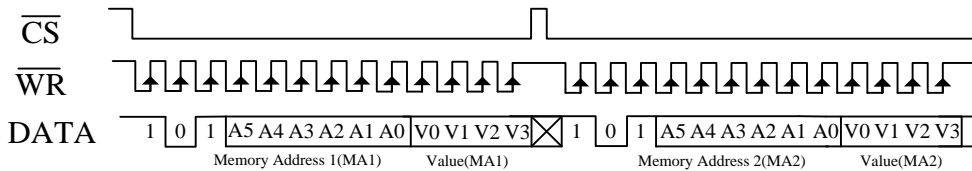

B.-2 Write Function (Successive Address Writing)

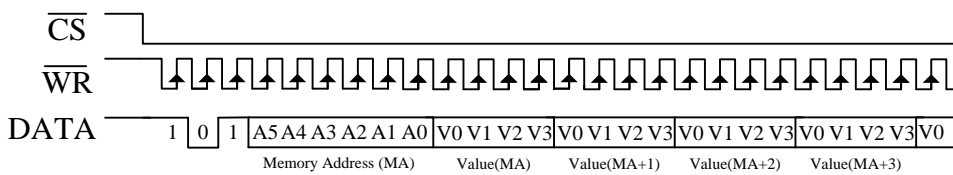

C.-1 Combination Function(Pre-Code:101)

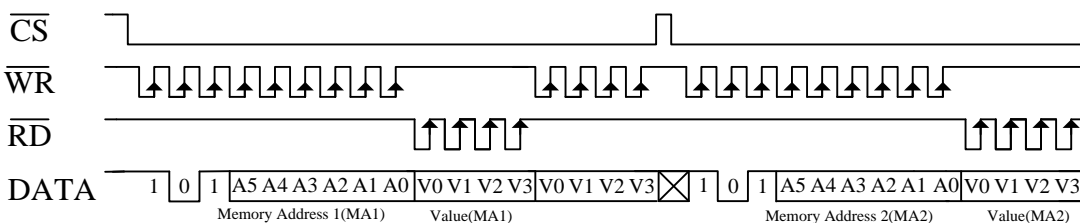



C.-2 Combination Function (Successive Address Accessing)

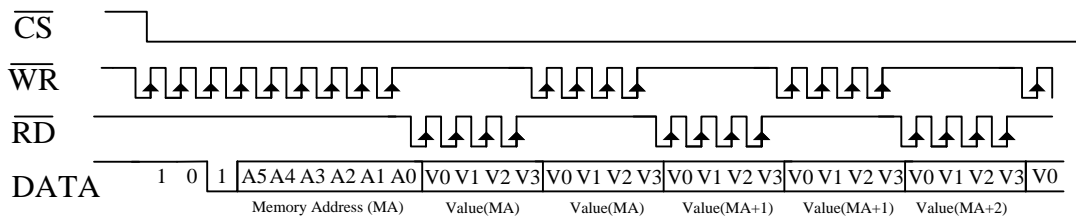

D.-1 System Function (Pre-Code:100)

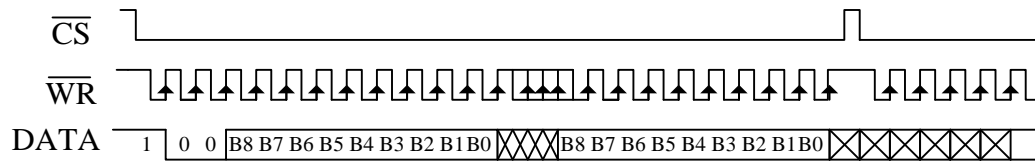

E. General Function (Pre-code and Address-Value)

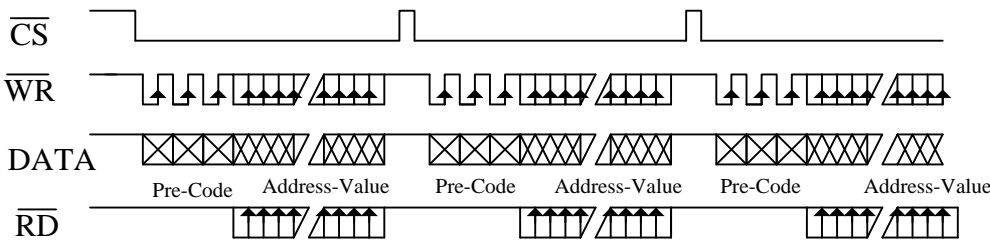



Pad Coordinate Diagram

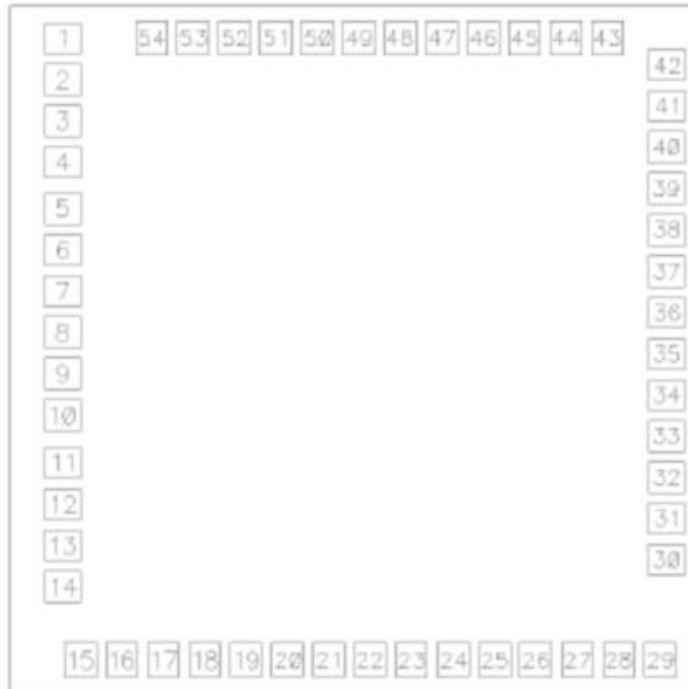

OUTLINE SIZE: 1910 × 1910 μm^2

SUBSTRATE floating (recommend) or VDD

NO	NAME	X	Y
1	CSB	-775.200	827.600
2	RDB	-775.200	717.600
3	WRB	-775.200	607.600
4	DATA	-775.200	497.600
5	VSS	-775.200	373.600
6	OSCI	-775.200	263.600
7	VDD	-775.200	153.600
8	VLCD	-775.200	43.600
9	IRQB	-775.200	-66.400
10	BZ	-775.200	-176.400
11	BZB	-775.200	-303.600
12	T1	-775.200	-413.600
13	T2	-775.200	-523.600
14	T3	-775.200	-633.600
15	COM0	-728.900	-828.500
16	COM1	-618.900	-828.500
17	COM2	-508.900	-828.500
18	COM3	-398.900	-828.500
19	COM4	-288.900	-828.500



VK1622S 32*8 液晶驅動 IC

20	COM5	-178.900	-828.500
21	COM6	-68.900	-828.500
22	COM7	41.100	-828.500
23	SEG0	151.100	-828.500
24	SEG1	261.100	-828.500
25	SEG2	371.100	-828.500
26	SEG3	481.100	-828.500
27	SEG4	591.100	-828.500
28	SEG5	701.100	-828.500
29	SEG6	811.050	-828.450
30	SEG7	828.550	-562.850
31	SEG8	828.550	-452.850
32	SEG9	828.550	-342.850
33	SEG10	828.550	-232.850
34	SEG11	828.550	-122.850
35	SEG12	828.550	-12.850
36	SEG13	828.550	97.150
37	SEG14	828.550	207.150
38	SEG15	828.550	317.150
39	SEG16	828.550	427.150
40	SEG17	828.550	537.150
41	SEG18	828.550	647.150
42	SEG19	828.550	757.150
43	SEG20	670.950	828.500
44	SEG21	560.950	828.500
45	SEG22	450.950	828.500
46	SEG23	340.950	828.500
47	SEG24	230.950	828.500
48	SEG25	120.950	828.500
49	SEG26	10.950	828.500
50	SEG27	-99.050	828.500
51	SEG28	-209.050	828.500
52	SEG29	-319.050	828.500
53	SEG30	-429.050	828.500
54	SEG31	-539.050	828.500