



VIA Labs, Inc.

Data Sheet

VL715
USB3.1 to SATA 6Gb/s
Bridge Controller

May 12, 2015
Revision 0.85

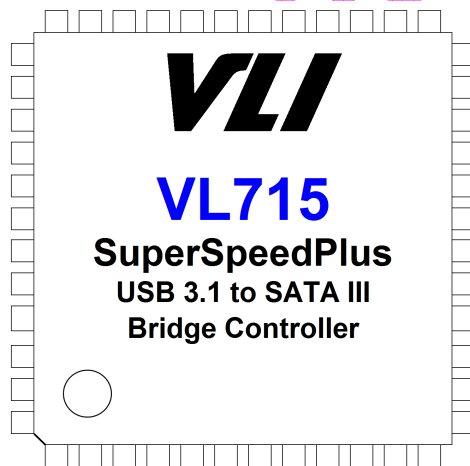

VIA Labs, Inc.
www.via-labs.com

7F, 529-1, Chung-Cheng Road,
Hsin-Tien, New Taipei City, Taiwan
Tel: (886-2) 2218-1838
Fax: (886-2) 2218-8924
Email: sales@via-labs.com.tw

Revision History

Rev	Date	Initial	Note
0.8	11/11/2014	HC	Preliminary release
0.85	05/12/2015	HC	Update GPIO driving spec, add GPIO7 with PWM

VLI CONFIDENTIAL

Table of Contents

Revision History	2
Table of Contents	3
List of Figures	3
List of Tables	3
Product Features	4
VL715 System Overview	5
Pinout	6
Pin List	8
Pin Descriptions	10
Signal Type Definition	10
Serial ATA Interface	10
USB 3.1 Interface	10
USB 2.0 Interface	10
Serial EEPROM Interface	10
Analog Command Block	11
General Purpose I/O and Miscellaneous	11
Test Pin	12
Power and Ground	12
Electrical Specification	13
Package Mechanical Specifications	21
Package Top Side Marking	23
Ordering Information	23

List of Figures

Figure 1 – VL715 Block Diagram	5
Figure 2 – VL715 QFN-48 Pin Diagram	6
Figure 3 – VL715 QFN-44 Pin Diagram	7
Figure 4 – 25MHz Crystal equivalent circuit and spec requirement	14
Figure 5 – QFN 48L 6x6x0.85 mm Mechanical Specification	21
Figure 6 – QFN 44L 6x5x0.85 mm Mechanical Specification	22
Figure 7 – VL715 Package Top Side Marking	23

List of Tables

Table 1 – VL715 QFN-48 Pin List	8
Table 2 – VL715 QFN-44 Pin List	9

Product Features

VL715

USB3.1 to SATA 6Gb/s Bridge Controller

- **SuperSpeedPlus USB (10Gb/s) and High-Speed USB (480Mb/s)**
 - Compliant to Universal Serial Bus 3.1 Specification Revision 1.0
 - Compliant to Universal Serial Bus Specification Revision 2.0
 - Mass Storage Class Bulk-Only Transport (BOT)
 - USB Attached SCSI Protocol (UASP) for streaming
 - Integrated in-house SuperSpeedPlus PHY and USB2.0 PHY
- **Serial ATA 6Gb/s, 3Gb/s and 1.5Gb/s**
 - Compliant to Serial ATA Specification Revision 3.1
 - Integrated in-house SATA 6Gb/s PHY
 - RBC command conversion for ATA device
 - MMC-2 command pass-through to ATAPI
 - Support 48-bit LBA
 - Support multiple LUN
- **Fast 8051 Macro cell 80C32-Compatible Microcontroller**
 - Standard 1T 8051 instruction set
- **Built-in Voltage Regulators**
 - 5.0V to 3.3V LDO
 - 5.0V to 1.2V switching DC-DC
- **GPIOs for Special Function Usage**
 - 7 GPIOs in QFN48 and QFN44 for customer special usage
 - 2 dedicated BUSY/POWER LED indicators
- **Misc**
 - Support device power down function
 - Support external SPI flash for firmware upgrade
- **Software**
 - Support Microsoft Windows 8, Windows 7, Vista, XP
 - Support Mac OS 10.X
 - Support various Linux kernels
- **Physical**
 - QFN 48L green package (6x6x0.85 mm)
 - QFN 44L green package (6x5x0.85 mm)
- **Certification**
 - USB-IF SuperSpeedPlus Certified: TBD

VL715 System Overview

VIA Lab's VL715 is a high performance, low power single chip USB 3.1 to SATA 6Gb/s bridge controller designed for new generation external storage devices that connecting Hard Disk Drive (HDD), Solid-State Drive (SSD), and Optical Disc Drive (ODD). Its integrated in-house USB 3.1 PHY enables VL715 to run in USB SuperSpeedPlus, Super-Speed, High-Speed, and Full-Speed modes. Supporting USB mass storage class Bulk-Only Transport (BOT), VL715 based devices can work on Windows 8, Windows 7, Vista, XP, Mac OS X and various Linux kernels without additional driver. Besides Bulk-Only Transport, VL715 also support USB Attached SCSI Protocol (UASP) that allowing mass storage command queuing and out of order data transfers to further enhance read/write performance. Its integrated in-house SATA 6Gb/s host controller can work with all SATA based storage devices and can connect at SATA 6Gb/s, SATA 3Gb/s, or SATA 1.5Gb/s automatically.

Built-in all required linear and switching voltage regulators, highly integrated VL715 work perfectly with single power input from USB 5V bus power to save customer BOM cost. 7 GPIO pins are available for push button, operation LEDs, device power down control, and other special usage. The SPI interface can support external flash for firmware upgrades or additional software enhancements. VL715 is pin to pin compatibility to its predecessor VL711 which can keep using the same PCB design. VL715 is available in QFN 48L (6x6x0.85 mm) and QFN 44L (6x5x0.85 mm) green packages to fit small form-factor design.

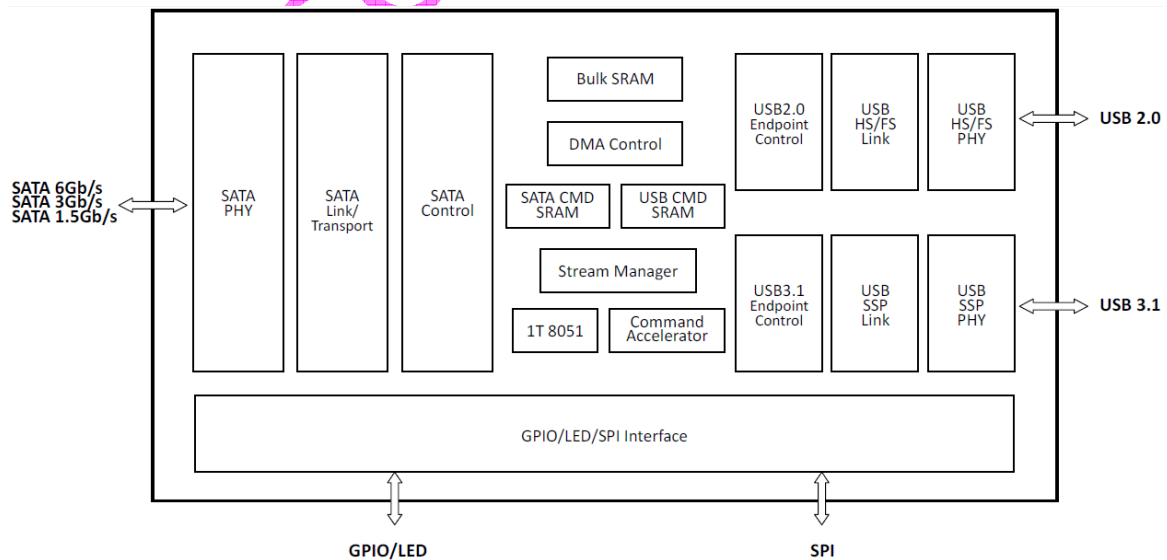

Figure 1 – VL715 Block Diagram

Pinout

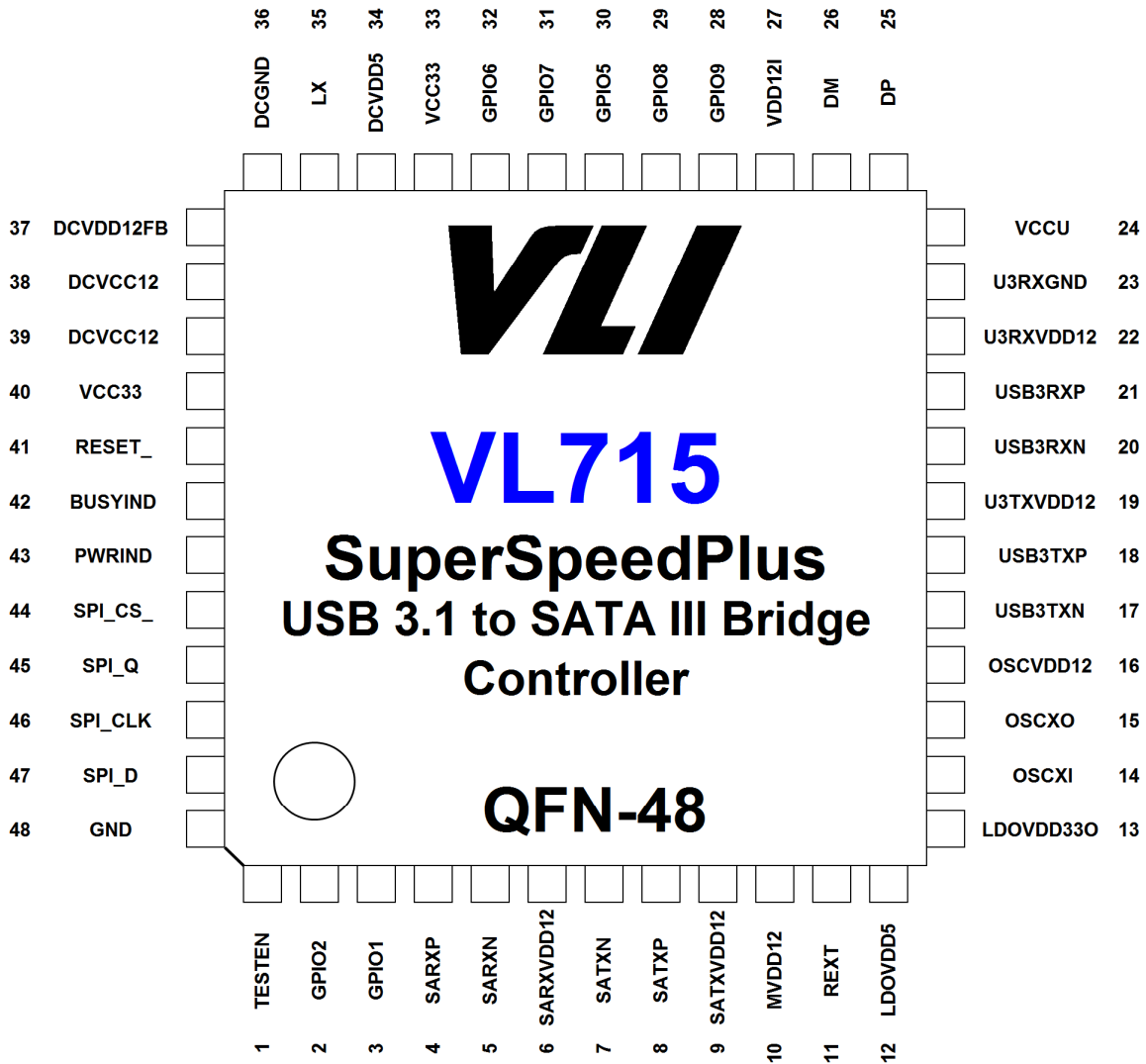

Figure 2 – VL715 QFN-48 Pin Diagram

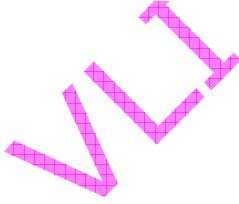
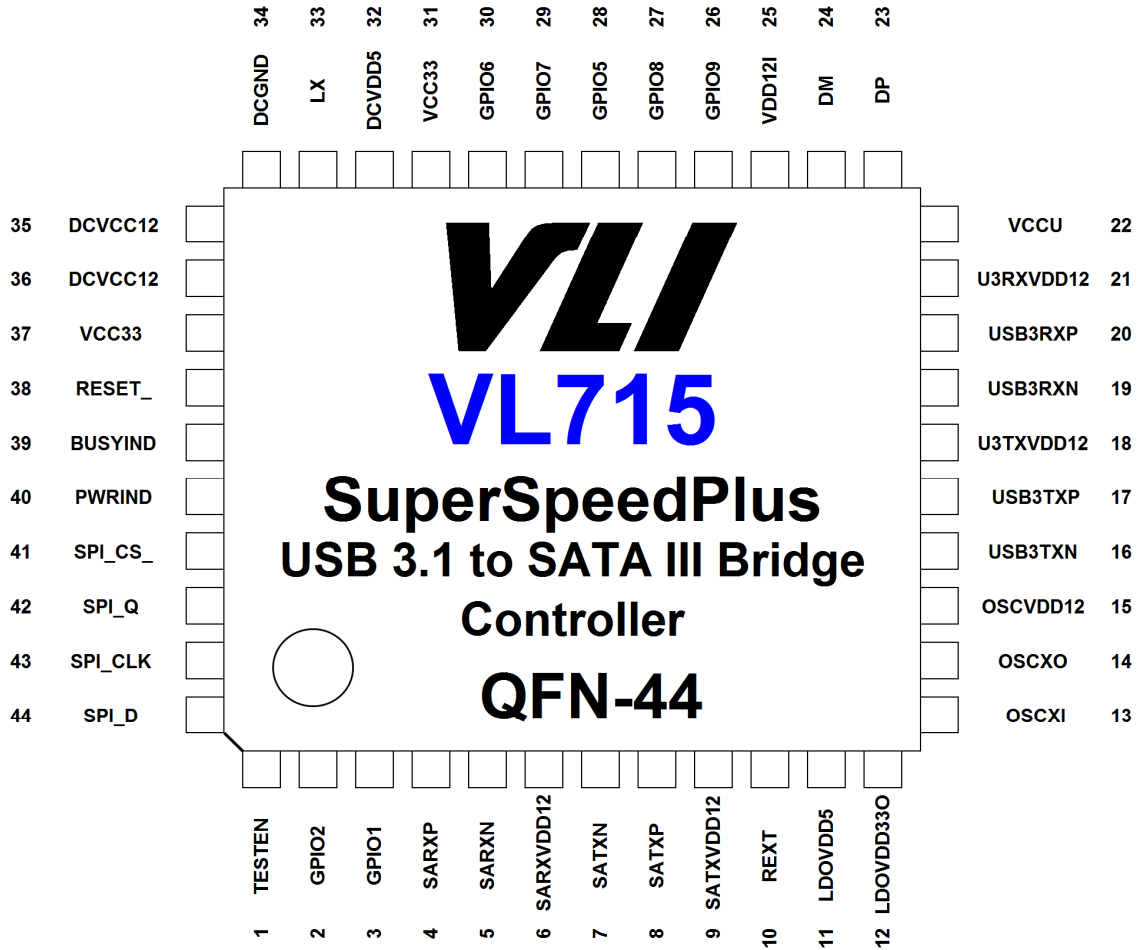

Figure 3 – VL715 QFN-44 Pin Diagram

Pin List

Table 1 – VL715 QFN-48 Pin List

Pin	Pin Name	Pin	Pin Name
1	TESTEN	25	DP
2	GPIO2	26	DM
3	GPIO1	27	VDD12I
4	SARXP	28	GPIO9
5	SARXN	29	GPIO8
6	SARXVDD12	30	GPIO5
7	SATXN	31	GPIO7
8	SATXP	32	GPIO6
9	SATXVDD12	33	VCC33
10	MVDD12	34	DCVDD5
11	REXT	35	LX
12	LDOVDD5	36	DCGND
13	LDOVDD330	37	DCVDD12FB
14	OSCXI	38	DCVCC12
15	OSCXO	39	DCVCC12
16	OSCVDD12	40	VCC33
17	USB3TXN	41	RESET_
18	USB3TXP	42	BUSYIND
19	U3TXVDD12	43	PWRIND
20	USB3RXN	44	SPI_CS_
21	USB3RXP	45	SPI_Q
22	U3RXVDD12	46	SPI_CLK
23	U3RXGND	47	SPI_D
24	VCCU	48	DGND

Table 2 – VL715 QFN-44 Pin List

Pin	Pin Name	Pin	Pin Name
1	TESTEN	23	DP
2	GPIO2	24	DM
3	GPIO1	25	VDD12I
4	SARXP	26	GPIO9
5	SARXN	27	GPIO8
6	SARXVDD12	28	GPIO5
7	SATXN	29	GPIO7
8	SATXP	30	GPIO6
9	SATXVDD12	31	VCC33
10	REXT	32	DCVDD5
11	LDOVDD5	33	LX
12	LDOVDD330	34	DCGND
13	OSCXI	35	DCVCC12
14	OSCXO	36	DCVCC12
15	OSCVDD12	37	VCC33
16	USB3TXN	38	RESET_
17	USB3TXP	39	BUSYIND
18	U3TXVDD12	40	PWRIND
19	USB3RXN	41	SPI_CS_
20	USB3RXP	42	SPI_Q
21	U3RXVDD12	43	SPI_CLK
22	VCCU	44	SPI_D

Pin Descriptions

Signal Type Definition

Name	Type	Signal Description
Input	I	A standard input-only signal
Output	O	A standard active driver
Input/Output	I/O	A bi-directional signal
Analog bias	A _{BIAS}	Analog bias or reference signal. Must be tied to external resistor and/or capacitor bias network
Power	PWR	A power pin
Ground	GND	A ground pin

Serial ATA Interface

Pin Name	QFN48	QFN44	I/O	Signal Description
SARXP	4	4	I	SATA Port Differential Receive Data +
SARXN	5	5	I	SATA Port Differential Receive Data -
SATXP	8	8	O	SATA Port Differential Transmit Data +
SATXN	7	7	O	SATA Port Differential Transmit Data -
SATXVDD12	9	9	PWR	Analog 1.2V
SARXVDD12	6	6	PWR	Analog 1.2V

USB 3.1 Interface

Pin Name	QFN48	QFN44	I/O	Signal Description
USB3RXP	21	20	I	USB 3.1 Port Differential Receive Data +
USB3RXN	20	19	I	USB 3.1 Port Differential Receive Data -
USB3TXP	18	17	O	USB 3.1 Port Differential Transmit Data +
USB3TXN	17	16	O	USB 3.1 Port Differential Transmit Data -
U3RXVDD12	22	21	PWR	Analog 1.2V
U3TXVDD12	19	18	PWR	Analog 1.2V
U3RXGND	23	—	GND	USB3 RX ground

USB 2.0 Interface

Pin Name	QFN48	QFN44	I/O	Signal Description
DP	25	23	I/O	USB 2.0 Bus Data Plus (D+)
DM	26	24	I/O	USB 2.0 Bus Data Minus (D-)
VCCU	24	22	PWR	Analog 3.3V

Serial EEPROM Interface

Pin Name	QFN48	QFN44	I/O	Signal Description
SPI_CS_	44	41	O	Serial Flash Chip Enable
SPI_D	47	44	O	Serial Flash Data Input
SPI_Q	45	42	I	Serial Flash Data Output
SPI_CLK	46	43	O	Serial Flash Clock

Analog Command Block

Pin Name	QFN48	QFN44	I/O	Signal Description
OSCXI	14	13	I	25M crystal input
OSCXO	15	14	O	25M crystal output
REXT	11	10	A _{BIAS}	Connect to external resistor
LDOVDD5	12	11	PWR	5.0V voltage input for 5V to 3.3V LDO
LDOVDD330	13	12	O	3.3V voltage output for 5V to 3.3V LDO
DCVDD5	34	32	PWR	5.0V voltage input for DC2DC regulator
LX	35	33	O	1.2V voltage output for DC2DC regulator
DCGND	36	34	GND	Ground for DC2DC regulator
DCVDD12FB	37	—	I	1.2V feedback for DC2DC regulator
DCVCC12	38	35	PWR	1.2V voltage input for core power
DCVCC12	39	36	PWR	1.2V voltage input for core power
MVDD12	10	—	PWR	Master analog 1.2V
OSCVDD12	16	15	PWR	Oscillator analog 1.2V

General Purpose I/O and Miscellaneous

Pin Name	QFN48	QFN44	I/O	Signal Description
BUSYIND	42	39	O	Busy LED Indicator, including PWM Typical Low Level Output Current I _{OL} = 22.6mA @ 0.4V (max); Typical High Level Output Current I _{OH} = 39.6mA @ 2.4V (min)
PWRIND	43	40	O	Power LED Indicator, including PWM Typical Low Level Output Current I _{OL} = 22.6mA @ 0.4V (max); Typical High Level Output Current I _{OH} = 39.6mA @ 2.4V (min)
RESET_	41	38	I	External Chip Reset
GPIO_1	3	3	I/O	General Purpose I/O (I _{OL} = 22.6mA @ 0.4V; I _{OH} = 39.6mA @ 2.4V in output mode) Default: Device power down control
GPIO_2	2	2	I/O	General Purpose I/O, including PWM (I _{OL} = 22.6mA @ 0.4V; I _{OH} = 39.6mA @ 2.4V in output mode) Default: USB3.1/USB2.0 mode indicator
GPIO_5	30	28	I/O	General Purpose I/O (I _{OL} = 22.6mA @ 0.4V; I _{OH} = 39.6mA @ 2.4V in output mode) Default: Push button trigger pin
GPIO_6	32	30	I/O	General Purpose I/O (I _{OL} = 22.6mA @ 0.4V; I _{OH} = 39.6mA @ 2.4V in output mode) Default: USB cable power detect
GPIO_7	31	29	I/O	General Purpose I/O, including PWM (I _{OL} = 22.6mA @ 0.4V; I _{OH} = 39.6mA @ 2.4V in output mode) Default: Device write protect control
GPIO_8	29	27	I/O	General Purpose I/O (I _{OL} = 22.6mA @ 0.4V; I _{OH} = 39.6mA @ 2.4V in output mode) Default: Push button status indicator
GPIO_9	28	26	I/O	General Purpose I/O (I _{OL} = 22.6mA @ 0.4V; I _{OH} = 39.6mA @ 2.4V in output mode) Default: EEPROM chip select & LED blinking mode select

Test Pin

Pin Name	QFN48	QFN44	I/O	Signal Description
TESTEN	1	1	I	Test Mode Enable Do not connect for normal operation. Internal pull down

Power and Ground

Pin Name	QFN48	QFN44	I/O	Signal Description
DGND	48	—	GND	Ground
VCC33	33, 40	31, 37	PWR	Digital IO power 3.3V
VDD12I	27	25	PWR	Digital Core power 1.2V

VLI CONFIDENTIAL

Electrical Specification

Absolute Maximum Rating

Symbol	Parameter	Min	Max	Unit	Note
T _{STG}	Storage Temperature	-55	125	°C	—
T _A	Ambient Temperature	0	70	°C	—
V _{DD33}	Power Supply Voltage	-0.5	3.69	V	—
V _{DD50}	Input Voltage	-0.5	5.5	V	—
V _O	Output Voltage at any output	-0.5	VCC+ 0.5	V	—
V _{ESD}	Electrostatic Discharge	—	2	kV	Human Body Model

Note: Stress above conditions may cause permanent damage to the device. Functional operation of this device should be restricted to the conditions described.

Operating Conditions

Symbol	Parameter	Min	Typ	Max	Unit
V _{CC33}	Digital IO power 3.3V	3.0	3.3	3.6	V
LDOVDD5	5V to 3.3V LDO 5V Power Input	4.5	5	5.5	V
DCVDD5	5V to 1.2V DC2DC 5V Power Input	4.5	5	5.5	V
V _{DD12I}	Digital Core power 1.2V	1.08	1.2	1.36	V
DGND	Ground	—	0	—	V

General IO DC Characteristics

Symbol	Parameter	Min	Max	Unit	Note
V _{IL}	Input Low Voltage	-0.30	0.8	V	—
V _{IH}	Input High Voltage	2.0	3.6	V	—
V _{OL}	Output Low Voltage	—	0.4	V	IOL=15.8mA
V _{OH}	Output High Voltage	2.4	—	V	IOH=26.5mA
I _{IL}	Input Leakage Current	—	+/-10	μA	0<VIN<VCC
I _{OZ}	Tristate Leakage Current	—	+/-10	μA	0<VOUT<VCC

Internal 5V to 1.2V DC/DC Converter

Parameter	Min	Typ.	Max	Unit	Note
Input Voltage	4.5	5.0	5.5	V	
Output Voltage	1.14	1.2	1.26	V	
Max. Output Current		TBD	TBD	mA	
Output Voltage Tolerance		+/- 5%			

Internal 5V to 3.3V LDO Regulator

Parameter	Min	Typ.	Max	Unit	Note
Input Voltage	4.5	5.0	5.5	V	



Output Voltage	3.135	3.3	3.465	V
Max. Output Current		TBD	TBD	mA
Output Voltage Tolerance		+/- 5%		

External Crystal Electrical Characteristics

Please refer to the Figure 4.

Symbol	Parameter	Min	Typ	Max	Unit
FL	Normal Frequency		25		MHz
	Oscillation Mode		Fundamental		
	Frequency Tolerance	-30		30	ppm
	Aging	-5		5	ppm
CL	Loading Capacitance		20		pf
C0	Shunt Capacitance	1	3	7	pf
Rr	Effective Resistance			50	ohms

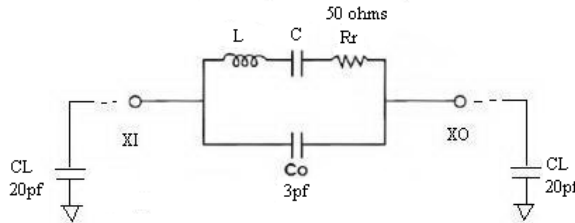

Figure 4 – 25MHz Crystal equivalent circuit and spec requirement

USB Full Speed DC/AC Characteristics

Symbol	Parameter	Min	Max	Unit	Note
VFSIH	Full-speed Input High	2.0		V	—
VFSIL	Full-speed Input Low		0.8	V	—
VFSCM	Differential Common Mode Voltage	0.8	2.5	V	—
VFSOL	Full-speed Output Low	0.0	0.3	V	—
VFSOH	Full-speed Output High	2.8	3.6	V	—
TFSR	Full-speed Rise Time	4	20	ns	—
TFSF	Full-speed Fall Time	4	20	ns	—
VFSCRS	Full-speed Output Signal Crossover Voltage	1.3	2.0	V	—

USB High Speed DC/AC Characteristics

Symbol	Parameter	Min	Max	Unit	Note
VHSSQ	High-speed squelch detection threshold	100	150	mV	—
VHSCM	High-speed data signaling common mode voltage	-50	500	mV	—
VHSOI	High-speed idle level	-10	10	mV	—
VHSOH	High-speed data high	360	440	mV	—



V _{HSOL}	High-speed data low	-10	10	mV	—
V _{CHIRPJ}	Chirp J level	700	1100	mV	—
V _{CHIRPK}	Chirp K level	-900	-500	mV	—
Z _{HSDRV}	Drive output resistance	40.5	49.5	Ω	—
T _{HSR}	High-speed Rise Time	500		ps	—
T _{HSF}	High-speed Fall Time	500		ps	—

USB SuperSpeedPlus TX RX Characteristics

TBD

USB Super Speed TX Characteristics

Symbol	Parameter	Min	Max	Unit	Note
V _{TX-DIFF-PP}	Differential p-p Tx swing	0.8	1.2	V	—
V _{TX-DE-RATIO}	Tx de-emphasis	3.0	4.0	dB	—
R _{TX-DIFF-DC}	DC differential impedance	72	120	Ω	—
V _{TX-RCV-DETECT}	The Voltage Change allowed during Receiver Detection		0.6	V	—
T _{TX-EYE}	Transmitter Eye	0.625		UI	—
T _{TX-DJ-DD}	Tx Deterministic Jitter		0.205	UI	—
R _{TX-DC}	Transmitter DC Common Mode Impedance	18	30	Ω	—
V _{TX-DC-CM}	Transmitter DC Common Mode Voltage	0	2.2	V	—
V _{TX-CM-AC-PP-AC-TIVE}	Tx AC Common Mode Voltage Active		100	mV	—
V _{TX-IDLE-DIFF-AC-PP}	Electrical Idle Differential P-P Output Voltage	0	10	mV	—
V _{TX-IDLE-DIFF-DC}	DC Electrical Idle Differential Output Voltage	0	10	mV	—

USB Super Speed RX Characteristics (5.0 GT/s)

Symbol	Parameter	Min	Max	Unit	Note
UI	Unit Interval	199.94	200.06	ps	UI does not account for SSC caused variations
R _{RX-DC}	Receiver DC common mode impedance	18	30	Ω	DC impedance limits are needed to guarantee Receiver detect Measured with respect to ground over a voltage of 500mV maximum
R _{RX-DIFF-DC}	DC differential impedance	72	120	Ω	
Z _{RX-HIGH-IMP-DC-POS}	DC Input CM Input Impedance for V>0 during Reset or power down	25k		Ω	Rx DC CM impedance with the Rx terminations not powered, measured over the range 0 – 500mv with respect to ground



$V_{RX-LFPS-DET-DIFF-P-P}$	LFPS Detect Threshold	100	300	mV	Below the minimum is noise Must wake up above the maximum
$V_{RX-DIFF-PP-POST-EQ}$	Differential Rx peak-to-peak voltage	30		mV	Measured after the Rx EQ function (Section 6.8.2)
t_{RX-TJ}	Max Rx inherent timing error		0.45	UI	Measured after the Rx EQ function (Section 6.8.2)
$t_{RX-DJ-DD}$	Max Rx inherent deterministic timing error		0.3	UI	Maximum Rx inherent deterministic timing error
$C_{RX-PARASITIC}$	Rx input capacitance for return loss		1.1	pf	
$V_{RX-CM-AC-P}$	Rx AC common mode voltage		150	mV Peak	Measured at Rx pins into a pair of 50Ω terminations into ground Includes Tx and channel conversion, AC range up to 5 GHz
$V_{RX-CM-DC-ACTIVE-IDLE-DELTA-P}$	Rx AC common mode voltage during the U1 to U0 transition		200	mV Peak	Measured at Rx pins into a pair of 50Ω terminations into ground Includes Tx and channel conversion, AC range up to 5 GHz

SATA TX Characteristics

Symbol	Parameter	Min	Max	Unit	Note
Z_{diffTX}	TX Pair Differential Impedance	85	115	Ohm	
Z_{s-eTX}	TX Single-Ended Impedance	40			
$RL_{DD11,TX}$	TX Differential Mode Return Loss (150MHz-300MHz)	14		dB	
	TX Differential Mode Return Loss (300MHz-600MHz)	8		dB	
	TX Differential Mode Return Loss (600MHz-1.2GHz)	6		dB	
	TX Differential Mode Return Loss (1.2GHz-2.4GHz)	6		dB	
	TX Differential Mode Return Loss (2.4GHz-3.0GHz)	3		dB	
	TX Differential Mode Return Loss (3.0GHz-5.0GHz)	1		dB	Only for Gen2i
$RL_{DD11,TX}$	TX Differential Mode Return Loss Start for slope for Gen3	Min at 300MHz z is 14		dB	

	Slope of TX Differential Mode Return Loss for Gen3	-13		dB/dec	
	TX Differential Mode Return Loss Max Frequency for Gen3		Max is 3	GHz	
RL _{CC11,TX}	TX Common Mode Return Loss (150MHz-300MHz)	8		dB	
	TX Common Mode Return Loss (300MHz-600MHz)	5		dB	
	TX Common Mode Return Loss (600MHz-1.2GHz)	2		dB	
	TX Common Mode Return Loss (1.2GHz-2.4GHz)	1		dB	
	TX Common Mode Return Loss (2.4GHz-3.0GHz)	1		dB	
	TX Common Mode Return Loss (3.0GHz-5.0GHz)	1		dB	Only for Gen2i
RL _{DC11,TX}	TX Impedance Balance (150MHz-300MHz)	30		dB	
	TX Impedance Balance (300MHz-600MHz)	20		dB	
	TX Impedance Balance (600MHz-1.2GHz)	10		dB	
	TX Impedance Balance (1.2GHz-2.4GHz)	10		dB	
	TX Impedance Balance (2.4GHz-3.0GHz)	4/10		dB	For Gen3i is 10dB
	TX Impedance Balance (3.0GHz-5.0GHz)	4		dB	
	TX Impedance Balance (5.0GHz-6.5GHz)	4			Only for Gen3i
V _{diffTX}	TX Differential Output Voltage	400	600	mVppd	For Gen1
	TX Differential Output Voltage	400	700	mVppd	For Gen2
	TX Differential Output Voltage	200	900	mVppd	For Gen3
UI _{VminTX}	TX Minimum Voltage Measurement Interval	0.45	0.55	UI	
t _{20-80TX}	TX Rise/Fall Time	100	273	ps	For Gen1
	TX Rise/Fall Time	67	136	ps	For Gen2
	TX Rise/Fall Time	33	80	ps	For Gen3
t _{skewTX}	TX Differential Skew		20	ps	
V _{cm,acTX}	TX AC Common Mode Voltage		50	mVp-p	
	TX AC Common Mode Voltage 3 GHz Max		26	dBmV(rms)	For Gen3
	TX AC Common Mode Voltage 6 GHz Max		30	dBmV(rms)	For Gen3
D _{vdiffOOB}	OOB Differential Delta		25	mV	
D _{vcmOOB}	OOB Common Mode Delta		50	mV	
R/F _{bal}	TX Rise/Fall Imbalance		20	%	Only for Gen2
Amp _{bal}	TX Amplitude Imbalance		30	%	Only for Gen2

TJ at Connector Clk-Data f _{BAUD} /500 JTF Defined		0.37	UI	For Gen1/Gen2
DJ at Connector Clk-Data f _{BAUD} /500 JTF Defined		0.19	UI	For Gen1/Gen2
Jitter Transfer Function Bandwidth (D24.3,high pass -3dB)	1.1	3.1	MHz	For Gen1/Gen2
Jitter Transfer Function Peaking		3.5	dB	For Gen1/Gen2
Jitter Transfer Function Low Frequency Attenuation	69	75	db	For Gen1/Gen2
Jitter Transfer Function Bandwidth (D24.3,high pass -3dB)	2.2	6.2	MHz	For Gen3
Jitter Transfer Function Peaking		3.5	dB	For Gen3
Jitter Transfer Function Low Frequency Attenuation	35.2	41.2	db	For Gen3
TJ(10-12)before and after CIC,Clk-Data JTF Defined		0.52	UI	For Gen3
TJ(10-6)before and after CIC,Clk-Data JTF Defined		0.46	UI	For Gen3

SATA RX Characteristics

Symbol	Parameter	Min	Max	Unit	Note
V _{diffRX}	Gen1 RX Differential Input Voltage	240	600	mVppd	
	Gen2 RX Differential Input Voltage	240	750		
	Gen3 RX Differential Input Voltage	240	1000		
t _{20-80RX}	Gen1 RX Rise/Fall time	100	273	ps	
	Gen2 RX Rise/Fall time	67	136		
	Gen2 RX Rise/Fall time	62	75		
t _{skewRX}	Gen2 RX Differential Skew		50	Ps	
	Gen3 RX Differential Skew		30		
V _{cm,acRX}	RX AC Common Mode Voltage		100	mVppd	
f _{cm,acRX}	RX AC Common Mode Frequency	2	200	MHz	
	Gen1 TJ at Connector, Data-Data, 5UI		0.43	UI	
	Gen1 DJ at Connector, Data-Data, 5UI		0.25	UI	
	Gen1 TJ at Connector, Data-Data, 250UI		0.6	UI	
	Gen1 TJ at Connector, Data-Data, 250UI		0.35	UI	
	Gen2 TJ at Connector, Clk-Data, f _{BAUD} /10		0.46	UI	
	Gen2 DJ at Connector, Clk-Data, f _{BAUD} /10		0.35	UI	
	Gen2 TJ at Connector, Clk-Data, f _{BAUD} /500		0.60	UI	



	Gen2 DJ at Connector, Clk-Data, $f_{BAUD}/500$		0.42		UI
Gen3 TJ after CIC	Clk-Data JTF Defined		0.60		UI
Gen3 RJ before CIC	MFTP Clk-Data JTF Defined		0.60		
Z_{diffRX}	RX Pair Differential Impedance	85	115		Ohm
Z_{s-eRX}	RX single-ended Impedance	40			Ohm
$RL_{DD11,RX}$	Gen2i/m RX Differential Mode Return Loss (150MHz-300MHz)	18			dB
	Gen2i/m RX Differential Mode Return Loss (300MHz-600MHz)	14			dB
	Gen2i/m RX Differential Mode Return Loss (600MHz-1.2GHz)	10			dB
	Gen2i/m RX Differential Mode Return Loss (1.2GHz-2.4GHz)	8			dB
	Gen2i/m RX Differential Mode Return Loss (2.4GHz-3.0GHz)	3			dB
	Gen2i/m RX Differential Mode Return Loss (3.0GHz-5.0GHz)	1			dB
	Gen3i RX Differential Mode Return Loss (min @ 300MHz)			18	
Gen3i Slop of RX Differential Mode Return Loss		-13			dB/dec
Gen3i RX Differential Mode Return Loss max frequency			6.0		GHz
RL_{CC11}	Gen2i/m RX Common Mode Return Loss (150MHz-300MHz)	5			dB
	Gen2i/m RX Common Mode Return Loss (300MHz-600MHz)	5			dB
	Gen2i/m RX Common Mode Return Loss (600MHz-1.2GHz)	2			dB
	Gen2i/m RX Common Mode Return Loss (1.2GHz-2.4GHz)	1			dB
	Gen2i/m RX Common Mode Return Loss (2.4GHz-3.0GHz)	1			dB
	Gen2i/m RX Common Mode Return Loss (3.0GHz-5.0GHz)	1			dB
V_{thresh}	Gen1 OOB Signal Detection Threshold	50	200		mVppd
	Gen2/3 OOB Signal Detection Threshold	75	200		mVppd
UI_{OOB}	UI During OOB Signaling	646.67	686.67		ps
	COMINIT/COMRESET/COMWA KE Transmit Burst Length	160	160		UI_{OOB}
	COMINIT/COMRESET Transmit Gap Length	480	480		UI_{OOB}
	COMWAKE Transmit Gap Length	160	160		UI_{OOB}
	COMWAKE Gap Detection Window	55	175		ns

COMINIT/COMRESET Gap	175	525	ns
Detection Window			

VLI CONFIDENTIAL

Package Mechanical Specifications

QFN-48 Pb-free Maximum Temperature for IR Reflow

Parameter	Value	Unit
Maximum Temperature T_p	250	°C
Max Time within 5°C of T_p	30	seconds

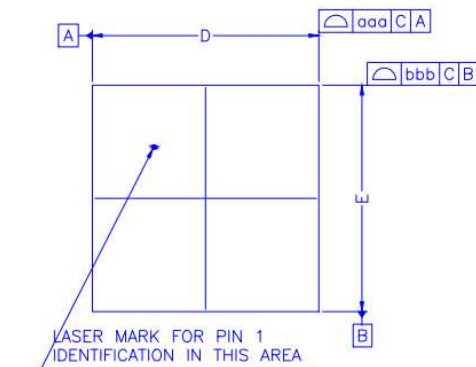

TOP VIEW

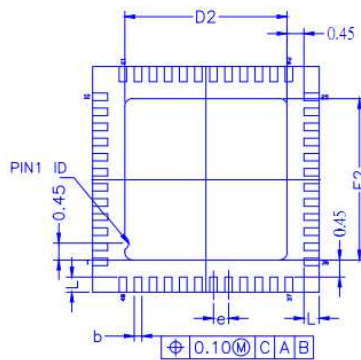

BOTTOM VIEW

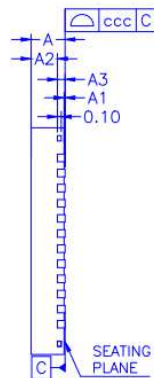

SIDE VIEW

* CONTROLLING DIMENSION : MM

SYMBOL	MILLIMETER			INCH		
	MIN.	NOM.	MAX.	MIN.	NOM.	MAX.
A	0.80	0.85	0.90	0.031	0.033	0.035
A1	0.00	0.035	0.05	0.000	0.001	0.002
A2	---	0.65	0.70	---	0.026	0.028
A3	0.203	REF.		0.008	REF.	
b	0.15	0.20	0.25	0.006	0.008	0.010
D	6.00 bsc			0.236 bsc		
D2	4.20	4.30	4.40	0.165	0.165	0.173
E	6.00 bsc			0.236 bsc		
E2	4.20	4.30	4.40	0.165	0.165	0.173
L	0.35	0.40	0.45	0.014	0.016	0.018
e	0.40 bsc			0.016 bsc		
TOLERANCES OF FORM AND POSITION						
aaa	0.10			0.004		
bbb	0.10			0.004		
ccc	0.08			0.003		

NOTES :

1. ALL DIMENSIONS ARE IN MILLIMETERS.
2. DIE THICKNESS ALLOWABLE IS 0.305 mm MAXIMUM (0.012 INCHES MAXIMUM)
3. DIMENSIONING & TOLERANCES CONFORM TO ASME Y14.5M, -1994.
4. THE PIN #1 IDENTIFIER MUST BE PLACED ON THE TOP SURFACE OF THE PACKAGE BY USING INDENTATION MARK OR OTHER FEATURE OF PACKAGE BODY.
5. EXACT SHAPE AND SIZE OF THIS FEATURE IS OPTIONAL.
6. PACKAGE WARPAGE MAX 0.08 mm.
7. APPLIED FOR EXPOSED PAD AND TERMINALS. EXCLUDE EMBEDDING PART OF EXPOSED PAD FROM MEASURING.
8. APPLIED ONLY TO TERMINALS.

Figure 5 – QFN 48L 6x6x0.85 mm Mechanical Specification

QFN-44 Pb-free Maximum Temperature for IR Reflow

Parameter	Value	Unit
Maximum Temperature T_p	250	°C
Max Time within 5°C of T_p	30	seconds

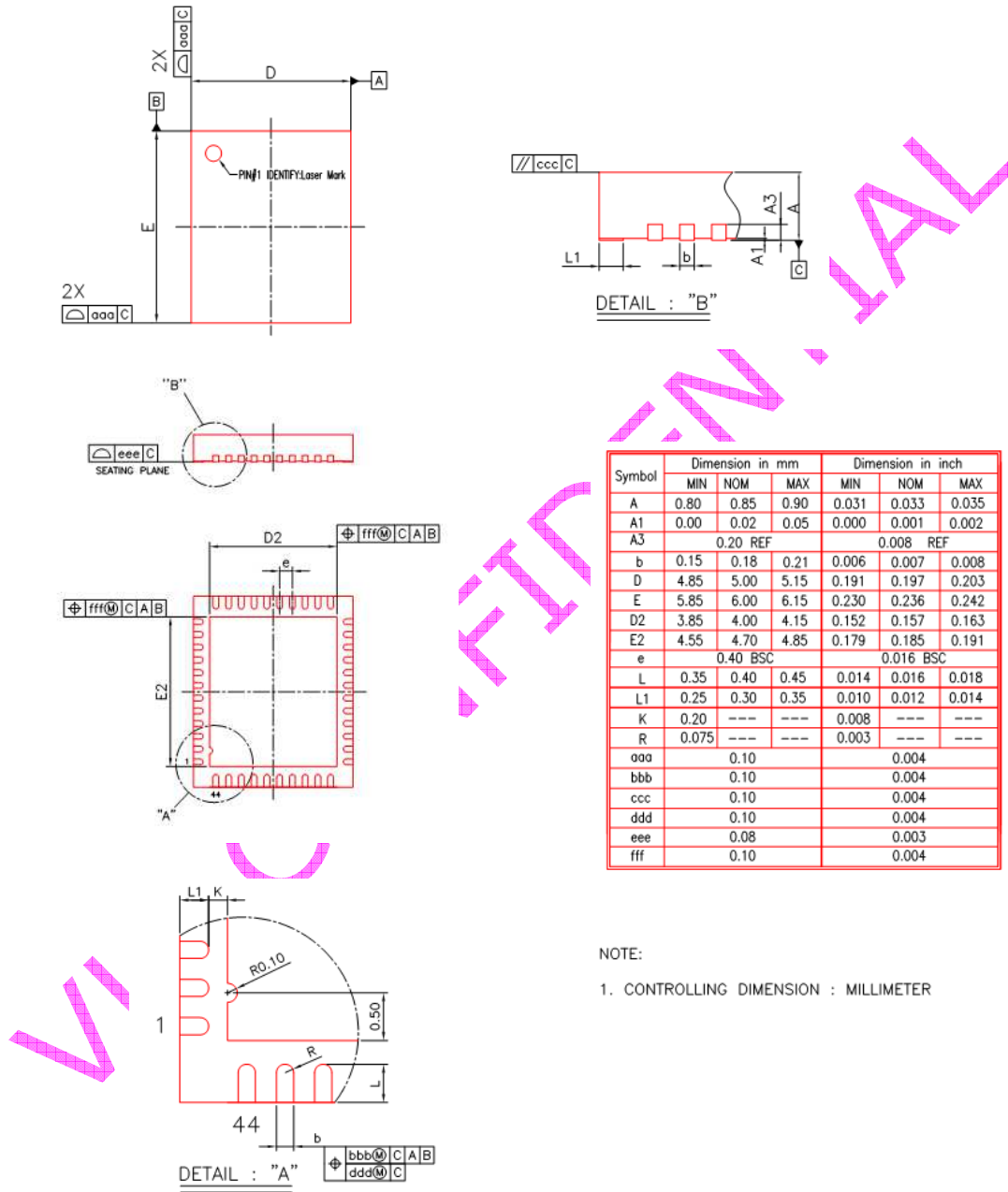

Figure 6 – QFN 44L 6x5x0.85 mm Mechanical Specification

Package Top Side Marking

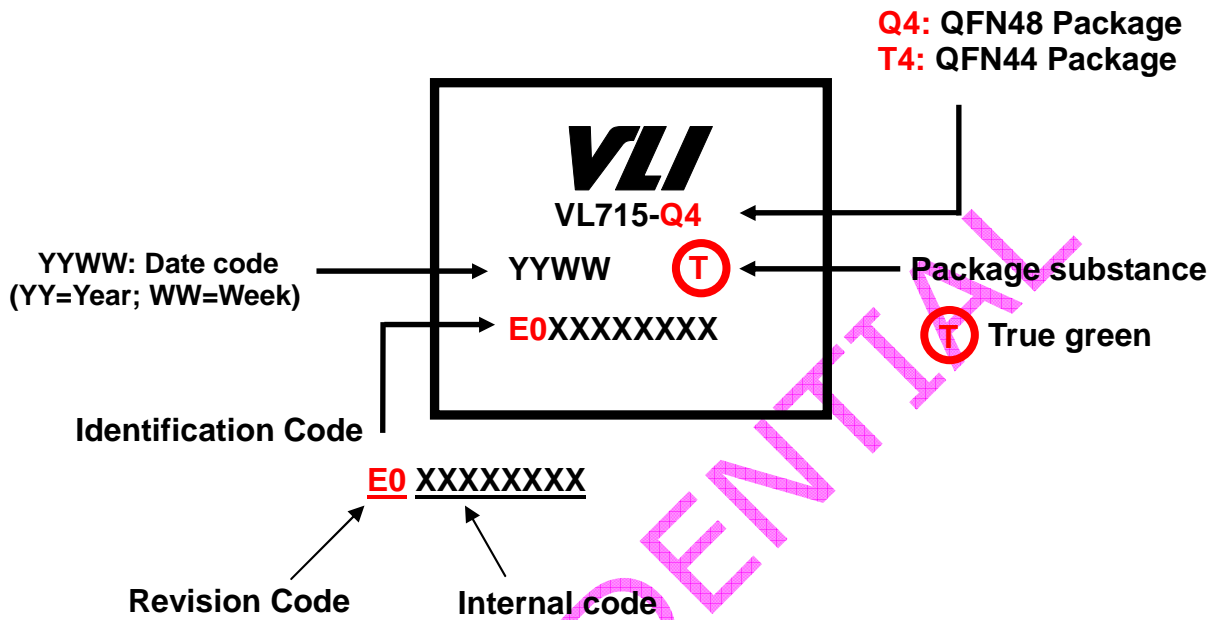

Figure 7 - VL715 Package Top Side Marking

Ordering Information

Part Number	Description	Package
VL715-Q4	USB3.1 to SATA 6Gb/s bridge	48-pin QFN (6x6mm)
VL715-T4	USB3.1 to SATA 6Gb/s bridge	44-pin QFN (6x5mm)

VIA Labs, Inc.
www.via-labs.com

7F, 529-1, Chung-Cheng Road,
Hsin-Tien, New Taipei City, Taiwan
Tel: (886-2) 2218-1838
Fax: (886-2) 2218-8924
Email: sales@via-labs.com.tw

Copyright © 2010 VIA Labs, Inc. All Rights Reserved.

No part of this document may be reproduced, transmitted, transcribed, stored in a retrieval system, or translated into any language, in any form or by any means, electronic, mechanical, magnetic, optical, chemical, manual or otherwise without the prior written permission of VIA Labs, Inc. The material in this document is for information only and is subject to change without notice. VIA Labs, Inc. reserves the right to make changes in the product design without reservation and without notice to its users.

All trademarks are the properties of their respective owners.

No license is granted, implied or otherwise, under any patent or patent rights of VIA Labs, Inc. VIA Labs, Inc. makes no warranties, implied or otherwise, in regard to this document and to the products described in this document. The information provided by this document is believed to be accurate and reliable as of the publication date of this document. However, VIA Labs, Inc. assumes no responsibility for any errors in this document. Furthermore, VIA Labs, Inc. assumes no responsibility for the use or misuse of the information in this document and for any patent infringements that may arise from the use of this document. The information and product specifications within this document are subject to change at any time, without notice and without obligation to notify any person of such change.