



VIA Labs, Inc.

Data Sheet

VL813
USB 3.0 Hub Controller

July 22, 2015
Revision 1.00



VIA Labs, Inc.
www.via-labs.com

7F, 529-1, Zhongzheng Rd.,
Xindian District, New Taipei City 231 Taiwan
Tel: (886-2) 2218-1838
Fax: (886-2) 2218-8924
Email: sales@via-labs.com.tw

Revision History

Rev	Date	Initial	Note
0.90	1/29/2015	DS	First External Release
1.00	7/22/2015	TS	Update Ordering Information Update WHCK Logo for Windows 8.1/10

VLI CONFIDENTIAL

Contents

Revision History	2
Contents	3
List of Figures	3
Product Features	4
VL813 System Overview	5
Pinout	7
Pin List	8
Pin Descriptions	9
Signal Type Definition	9
USB 3.0 Interface	9
USB 2.0 Interface	10
Analog Command Block	10
Side Band signal and Miscellaneous	11
Test Pin	11
Power and Ground	10
Electrical Specification	12
Timing Requirements for SPI Flash	13
General Reflow Profile Guidelines	15
Package Mechanical Specifications	16
Package Top Side Marking & Ordering Information	17

List of Figures

Figure 1 – VL813 Block Diagram	5
Figure 2 – VL813 Pin Diagram	7
Figure 3 – Illustration of SPI Flash Interface Timing – (1)	14
Figure 4 – Illustration of SPI Flash Interface Timing – (2)	14
Figure 5 – Reflow	15
Figure 6 – Mechanical Specification – QFN 76L 9x9x0.85 mm Package	16
Figure 7 – Package Top Side Marking	17

Product Features

VL813

Super-Speed USB Hub Controller

USB 3.0 Compliant

- Compliant to Universal Serial Bus 3.0 Specification Rev 1.0, including Hub errata
- Compliant to Universal Serial Bus Specification Revision 2.0
- Supports simultaneous Super-speed(SS), high-speed (HS), full-speed (FS) traffic, and low-speed (LS) traffic
- Four down-stream ports, one up-stream port
- In-house USB PHY employs advanced CMOS process for low power consumption
- Supports USB Low-Power States such as Ux states, Selective Suspend, LPM

Integrated Voltage Regulators

- Able to generate all required chip-power from 5V input
 - 5V to 1.2V Switching DC-DC Regulator
 - 5V to 3.3V LDO Regulator
- External Power Support
 - 3.3V, 1.2V External Input

Simplified Sideband Signal Support

- Supports gang mode over current detection on down-stream ports
- Supports individual mode for power enable and over current detection on 1 port for battery charging function
- Supports Dual LED status indicators with automatic or manual control via GPIO per down-stream port (Typically Green & Amber)

Comprehensive USB Battery Charging Support

- Supports USB Battery Charging Specification v1.2 (SDP, CDP, DCP)
- Support for Vendor Specific Charging Modes eg. Apple, RIM, etc.
- Supports Apple 1.0A/2.4A Charging modes
- Supports YD/T 1591-2009
- Supports "Sleep Charging" (DCP + Apple Mode)
- Support charging on 1 down-stream port, depending on configuration

Physical

- QFN 76L green package (9x9x0.85 mm)

Certification

- Earned USB 2.0 USB-IF certification
- Earned USB 3.0 USB-IF certification TID# 330000022
- Passed Windows 8/8.1/10 WHCK Testing

Applications

- Standalone USB hub
- Desktop front panel hub/Integrated Monitor/TV hub
- Notebook/Ultrabook Docking Station / Port Replicator
- USB hub compound device with keyboard, mouse, display, etc.

Platform and Operating System Support

- General support across all major OS and platforms that offer USB such as PC, MAC, Linux, etc.
- FW Update over USB
- USB hub function is dependent upon the USB Host Controller
- No proprietary driver needed, even for Battery Charging Function

Misc

- Optimized for Low Power consumption
- PLL embedded with external 25MHz crystal
- Support external SPI flash for firmware upgrade

VL813 System Overview

VIA Lab's VL813 is an advanced 4-port USB 3.0 Hub controller featuring fully-integrated voltage regulators, low power consumption, and comprehensive USB Charging support. The integrated 5V DC-DC switching regulator enables VL813 to be powered directly from 5V USB VBus, reducing BOM cost while offering high power efficiency. The custom in-house USB PHY supports USB power management and gives VL813 excellent signal integrity characteristics and improved backwards compatibility. VL813 also features a flexible firmware architecture, providing a framework for custom functions in addition to in-field updates.

VL813 based hub devices work under Windows, Mac OS X, and various Linux kernels without additional drivers. Since USB 3.0 hubs do not require additional drivers, VL811+ is also compatible with non-x86 devices and platforms that support USB hub functions such as smart phones, tablets, and set-top boxes. It is well suited for all USB hub applications such as standalone USB hubs, Notebook/Ultrabook docking stations/port-replicators, desktop PC front panel, motherboard on-board hub, and USB hub compound devices.

With well-planned pinout and a high level of integration, VL813 based devices enjoy easy layout and simplified BOM. Sideband signal pins are available for showing power enable, over current, GPIO, and LED status control. The SPI interface supports external EEPROM/Flash ROM which can be updated over USB. VL813 is available in QFN 76L green package (9x9x0.85 mm) to fit small form-factor designs.

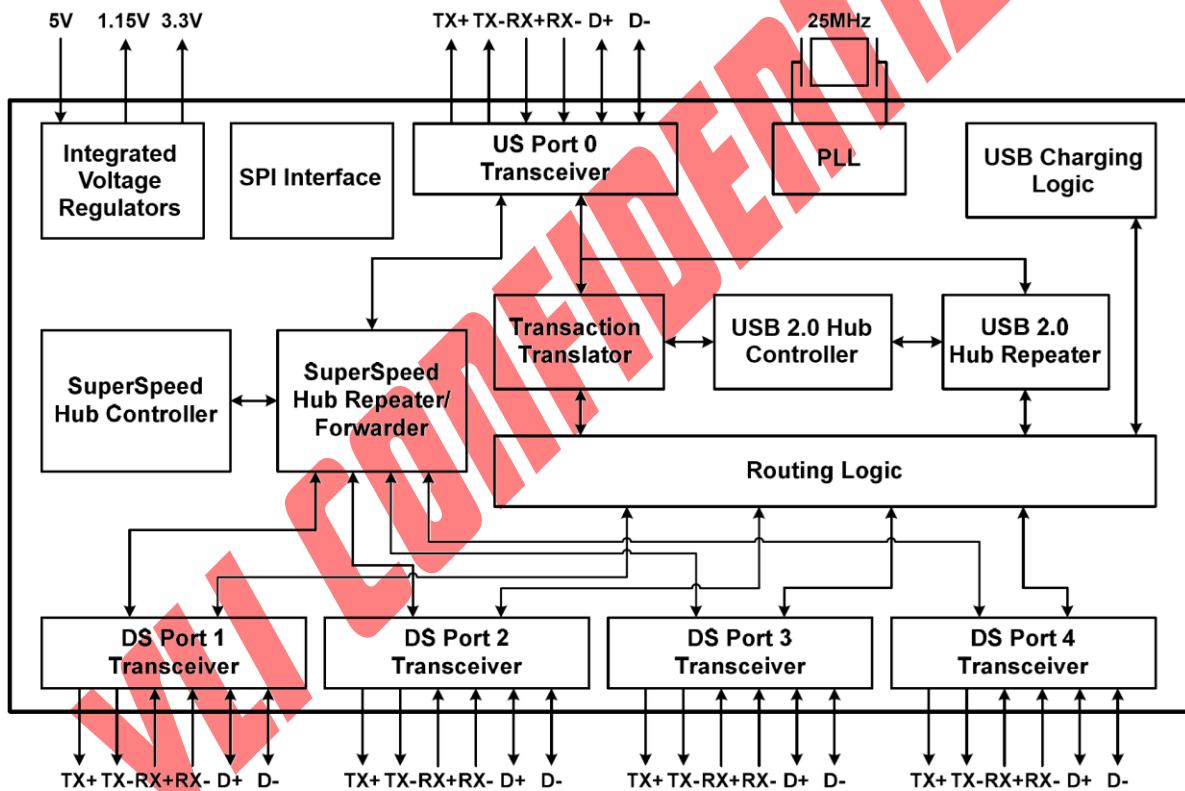

Figure 1 – VL813 Block Diagram

Rapid Charging over USB in Detail

3 Concepts of Rapid Charging over USB:

- **Rapid Charging over USB enables charging of devices at rates in excess of baseline USB standards.** The current limit of USB 2.0 is 500mA for configured devices, and the current limit of USB 3.0 is 900mA for configured devices. Depending on the device, Rapid Charging implementations typically feature current limits between 1000mA to 2000mA.
- **It is the Host/Hub's responsibility to advertise Rapid Charging capabilities, and it is the Device's responsibility to recognize and determine the Rapid Charging capabilities of the Host/Hub port it is connected to.** Since Rapid Charging over USB allows charging at rates in excess of USB spec, this detection mechanism is necessary to ensure safe and reliable operation, and can prevent situations where a device requests more current than what a host/hub port can supply. Also, this implies that Rapid Charging will only occur when both Host/Hub and Device supports it.
- **The rate at which a device charges is dependant upon the device.** This means that the device must determine the host/hub port's capabilities to determine which charging mode to use. Also, the rate at which a device charges can vary depending on the status of the device. For example, some devices only charge at their maximum rate when the battery is nearly depleted. When the battery is nearly full, they may switch to a trickle-charge mode. The Host/Hub rapid-charging port has no control over this behavior.

Supported USB Charging Modes

SDP – Standard Downstream Port

This is a typical USB 2.0 or USB 3.0 port and does not explicitly support Rapid USB Charging. SDP is constrained to the current limits as defined in the USB 2.0 or USB 3.0 spec which are 500mA and 900mA respectively. While the actual current limit is enforced by the polyfuse or power-switch providing current-limiting functionality for the downstream port, most USB devices will not draw more than 500mA or 900mA under USB 2.0 or USB 3.0 modes.

CDP – Charging Downstream Port

CDP is defined in the USB Battery Charging Specification 1.2 and enables devices that are able to correctly recognize CDP to simultaneously function as a USB device while drawing up to 1.5A for Rapid Charging when connected to the downstream port of a USB Host or Hub that advertises CDP capability.

DCP – Dedicated Charging Port

DCP is defined in the USB Battery Charging Specification 1.2 and has been in use on an unofficial basis prior to the official USB Battery Charging Specification. DCP is a dedicated charging mode, so when a device is charging under DCP, regular USB operations such as data transfer to the device are not supported.

Special Modes

Various vendors such as Apple, RIM, Motorola, etc may employ different detection mechanisms compared to other USB devices and thus, may enter Rapid Charging under the previously mentioned charging modes. VL811+ supports an auto detection mechanism that provides charging for the majority of devices.

Pinout

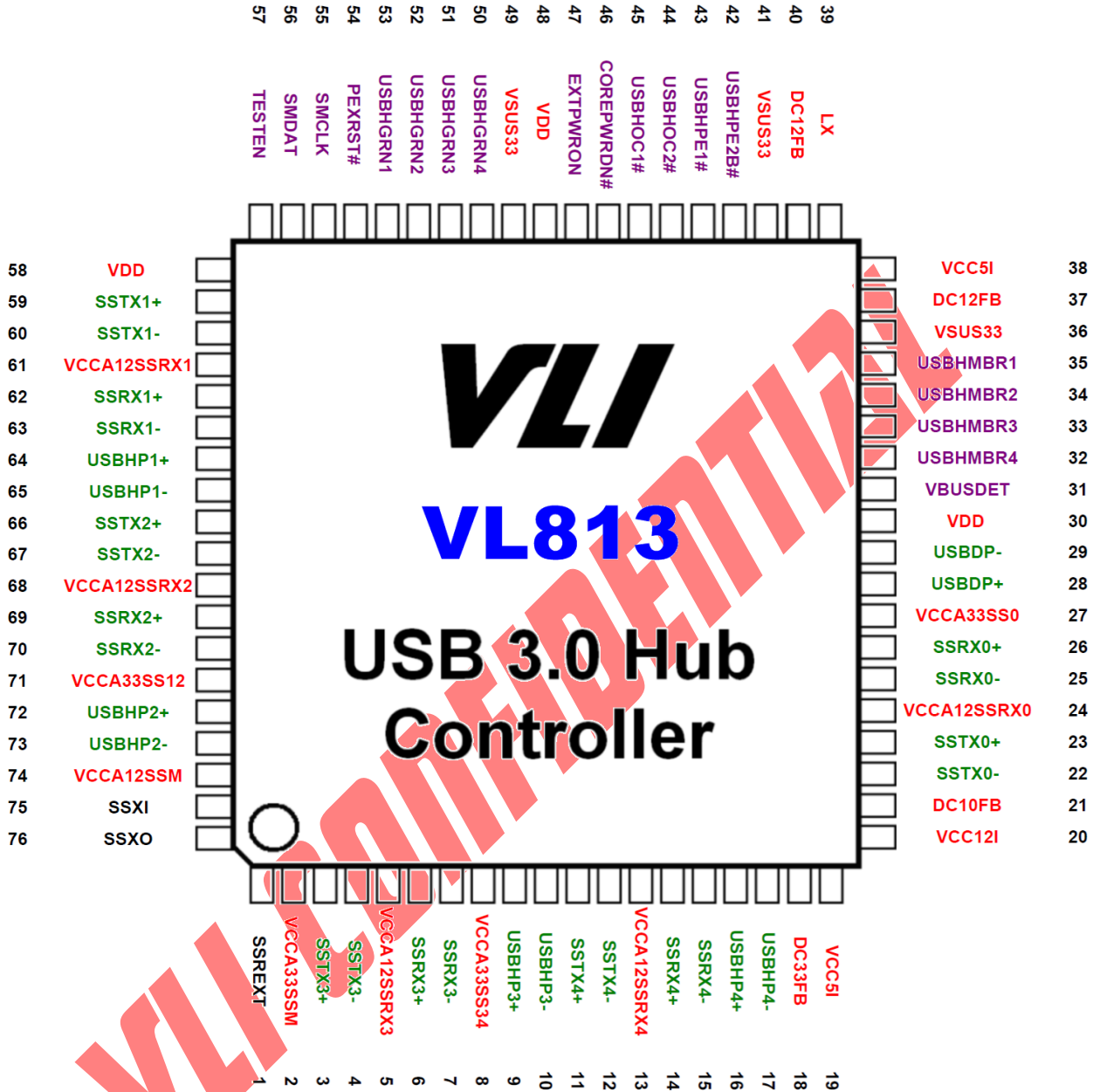

Figure 2 – VL813 Pin Diagram

Pin List

Table 1 – VL813+ Pin List

Pin	Pin Name	Pin	Pin Name
1	SSREXT	39	LX
2	VCCA33SSM	40	DC12FB
3	SSTX3+	41	VSUS33
4	SSTX3-	42	USBHPE2B#
5	VCCA12SSRX3	43	USBHPE1#
6	SSRX3+	44	USBHOC2#
7	SSRX3-	45	USBHOC1#
8	VCCA33SS34	46	COREPWRDN#
9	USBHP3+	47	EXTPWRON
10	USBHP3-	48	VDD
11	SSTX4+	49	VSUS33
12	SSTX4-	50	USBHGRN4
13	VCCA12SSRX4	51	USBHGRN3
14	SSRX4+	52	USBHGRN2
15	SSRX4-	53	USBHGRN1
16	USBHP4+	54	RESET#
17	USBHP4-	55	SMCLK
18	DC33FB	56	SMDAT
19	VCC5I	57	TESTEN
20	VCC12I	58	VDD
21	DC10FB	59	SSTX1+
22	SSTX0-	60	SSTX1-
23	SSTX0+	61	VCCA12SSRX1
24	VCCA12SSRX0	62	SSRX1+
25	SSRX0-	63	SSRX1-
26	SSRX0+	64	USBHP1+
27	VCCA33SS0	65	USBHP1-
28	USBDP+	66	SSTX2+
29	USBDP-	67	SSTX2-
30	VDD	68	VCCA12SSRX2
31	VBUSDET	69	SSRX2+
32	USBHMBR4	70	SSRX2-
33	USBHMBR3	71	VCCA33SS12
34	USBHMBR2	72	USBHP2+
35	USBHMBR1	73	USBHP2-
36	VSUS33	74	VCCA12SSM
37	DC12FB	75	SSXI
38	VCC5I	76	SSXO

Pin Descriptions

Signal Type Definition

Name	Type	Signal Description
Input	I	A logic input-only signal
Output	O	A logic output only signal
Input/Output	I/O	A logic bi-directional signal
Power	PWR	A power pin
Ground	GND	A ground pin

USB 3.0 Interface

Pin Name	Pin #	I/O	Signal Description
SSTX0+	23		USB 3.0 UP Port Differential Transmit Data +
SSTX0-	22		USB 3.0 UP Port Differential Transmit Data -
SSRX0+	26		USB 3.0 UP Port Differential Receive Data +
SSRX0-	25		USB 3.0 UP Port Differential Receive Data -
VCCA12SSRX0	24	PWR	Analog 1.2V
SSTX1+	59		USB 3.0 DP1 Port Differential Transmit Data +
SSTX1-	60		USB 3.0 DP1 Port Differential Transmit Data -
SSRX1+	62		USB 3.0 DP1 Port Differential Receive Data +
SSRX1-	63		USB 3.0 DP1 Port Differential Receive Data -
VCCA12SSRX1	61	PWR	Analog 1.2V
SSTX2+	66		USB 3.0 DP2 Port Differential Transmit Data +
SSTX2-	67		USB 3.0 DP2 Port Differential Transmit Data -
SSRX2+	69		USB 3.0 DP2 Port Differential Receive Data +
SSRX2-	70		USB 3.0 DP2 Port Differential Receive Data -
VCCA12SSRX2	68	PWR	Analog 1.2V
VCCA33SS12	71	PWR	Analog 3.3V
SSTX3+	3		USB 3.0 DP3 Port Differential Transmit Data +
SSTX3-	4		USB 3.0 DP3 Port Differential Transmit Data -
SSRX3+	6		USB 3.0 DP3 Port Differential Receive Data +
SSRX3-	7		USB 3.0 DP3 Port Differential Receive Data -
VCCA12SSRX3	5	PWR	Analog 1.2V
VCCA33SS34	8	PWR	Analog 3.3V
SSTX4+	11		USB 3.0 DP4 Port Differential Transmit Data +
SSTX4-	12		USB 3.0 DP4 Port Differential Transmit Data -
SSRX4+	14		USB 3.0 DP4 Port Differential Receive Data +
SSRX4-	15		USB 3.0 DP4 Port Differential Receive Data -
VCCA12SSRX4	13	PWR	Analog 1.2V
VCCA33SSM	2	PWR	USB 3.0 Master Block Analog 3.3V

USB 2.0 Interface

Pin Name	Pin #	I/O	Signal Description
USBDP+	28		USB 2.0 UP Bus Data Plus (D+)
USBDP-	29		USB 2.0 UP Bus Data Minus (D-)
VCCA33SS0	27	PWR	Analog 3.3V
USBHP1+	64		USB 2.0 DP1 Bus Data Plus (D+)
USBHP1-	65		USB 2.0 DP1 Bus Data Minus (D-)
USBHP2+	72		USB 2.0 DP2 Bus Data Plus (D+)
USBHP2-	73		USB 2.0 DP2 Bus Data Minus (D-)
USBHP3+	9		USB 2.0 DP3 Bus Data Plus (D+)
USBHP3-	10		USB 2.0 DP3 Bus Data Minus (D-)
USBHP4+	16		USB 2.0 DP4 Bus Data Plus (D+)
USBHP4-	17		USB 2.0 DP4 Bus Data Minus (D-)

Analog Command Block

Pin Name	Pin #	I/O	Signal Description
SSXI	75		25M crystal input
SSXO	76		25M crystal output
VCCA12SSM	74	PWR	Analog 1.2V
SSREXT	1		Connect to reference resistor for Super speed mode

Power and Ground

Pin Name	Pin #	I/O	Signal Description
GND	EPAD	GND	Ground
VDD	30,48,58	PWR	1.2V Core power
VSUS33	36,41,49	PWR	3.3V suspend power
VCC5I	19	PWR	5V Input for 5-3.3V Regulator
DC33FB	18	PWR	5-3.3V LDO Regulator Output
VCC12I	20	GND	Ground
DC10FB	21	FLOAT	NC (Float)
VCC5I	38	PWR	5V Input for integrated 5-1.2V Regulator
DC12FB	37, 40	PWR	5-1.2V DC-DC Switching Regulator Output
LX	39	PWR	LX for 5-1.2V DC-DC Switching Regulator

Side Band signal and Miscellaneous

Pin Name	Pin #	I/O	Signal Description
USBHMBR1	35	O	DP1 Amber (Over Current) LED Indicator and SPISO share pin. For LED, output high when active and external 100Kohm pull low required.
USBHMBR2	34	O	DP2 Amber (Over Current) LED Indicator and SPISI share pin. For LED, output high when active and external 100Kohm pull low required.
USBHMBR3	33	O	DP3 Amber (Over Current) LED Indicator / SPISCLK share pin. For LED, output high when active and external 100Kohm pull low required.
USBHMBR4	32	O	DP4 Amber (Over Current) LED Indicator / SPICS# share pin. For LED, output high when active and external 100Kohm pull low required.
USBHGRN1	53	O	DP1 Green (Port Connect) LED Indicator. Output high when active and external 100Kohm pull low required.
USBHGRN2	52	O	DP2 Green (Port Connect) LED Indicator. Output high when active and external 100Kohm pull low required.
USBHGRN3	51	O	DP3 Green (Port Connect) LED Indicator. Output high when active and external 100Kohm pull low required.
USBHGRN4	50	O	DP4 Green (Port Connect) LED Indicator. Output high when active and external 100Kohm pull low required.
USBHPE1#	43	O	Power Enable for Gangmode Ports Low: Port Power On. High: Port Power Off.
USBHPE2B#	42	O	Power Enable for USB Charging Port Low: Port Power On. High: Port Power Off.
USBHOC1#	45	I	DP1 Over Current Detect Low: Port Over Current High: Normal
USBHOC2#	44	I	DP2 Over Current Detect Low: Port Over Current High: Normal
EXTPWON	47	I	Upstream Port VBUS Detection for Upstream port plug-in
COREPWRDN#	46	O	Core power down (Reserved for controlling external core power switch)
VBUSDET	31	I	5V USB VBus Presence Detect
RESET#	54	I	System Reset Low: Reset High: Normal Operation

Test Pin

Pin Name	Pin #	I/O	Signal Description
TESTEN	57	I	Test Mode Enable Do not connect for normal operation. Internal pull down. Low: Normal mode. High: Test mode.
SMCLK	55	I	SMBus clock for debug only. It is not a standard SMBus interface. Open Drain
SMDAT	56	I/O	SMBus data for debug only. It is not a standard SMBus interface. Open Drain

Electrical Specification

Absolute Maximum Rating

Symbol	Parameter	Min	Max	Unit	Note
T _{STG}	Storage Temperature	-55	125	°C	—
V ₅₀	5V Power Supply Voltage	-0.5	5.5	V	—
V ₃₃	3.3V Power Supply Voltage	-0.5	3.63	V	—
V ₁₂	1.2V Input Voltage	-0.5	1.26	V	—
V _{IN}	Input voltage at I/O pins	-0.5	(≤ 3.63) and ($\leq V_{33}+0.3$)	V	—
V _{ESD}	Electrostatic Discharge	-2000	2000	V	Human Body Model
θ_{jc}	Thermal resistance between junction and case	<ul style="list-style-type: none"> ● For 4-layer PCB: 9.1 ● For 2-layer PCB: 11.3 		°C/W	2L & 4L PCB definitions follow JESD51-7
θ_{ja}	Thermal resistance between junction and ambient	<ul style="list-style-type: none"> ● For 4-layer PCB: 21.8 ● For 2-layer PCB: 56.8 		°C/W	
P _D	Power dissipation	—	1.0	W	—

Note: Stress above conditions may cause permanent damage to the device. Functional operation of this device should be restricted to the conditions described.

Note: About thermal factors, T_a is the concerned ambient temperature, and

$$\theta_{ca} = \theta_{ja} - \theta_{jc}$$

$$T_j = \theta_{ja} * P_D + T_a$$

$$T_c = \theta_{ca} * P_D + T_a$$

Operating Conditions

Symbol	Parameter	Min	Max	Unit	Note
T _A	Ambient Temperature	0	70	°C	—
T _j	Junction Temperature	0	125	°C	—
V ₅₀	5V Power Supply Voltage	4.75	5.25	V	—
V ₃₃	3.3V Power Supply Voltage	3.0	3.6	V	—
V ₁₂	1.2V Input Voltage	1.14	1.25	V	1.2V Nominal
V _{IL}	Input Low Voltage	—	0.8	V	—
V _{IH}	Input High Voltage	2.0	—	V	—
V _{OL}	Output Low Voltage	—	0.4	V	I _{OL} =4mA
V _{OH}	Output High Voltage	2.4	—	V	I _{OH} =4mA
I _{IL}	Input Leakage Current	—	+/-10	μA	0<V _i <V ₃₃
I _{OZ}	Tristate Leakage Current	—	+/-20	μA	0<V _o <V ₃₃

Timing Requirements for SPI Flash

SPI flash ROM is used to store the FW data for VL813. Timing guidelines are provided to assist in selection of appropriate and compatible SPI flash. To ensure SPI flash suitability, not only should the timing requirements conform to the provided guidelines, but actual testing with VL813 should also be done.

Symbol	Parameters	Condition	Value	Unit
f_{CT}	Clock Frequency for fast read mode(*)	Max value must larger than	15	MHz
f_c	Clock Frequency for read mode	Max value must larger than	15	MHz
t_{RI}	Input Rise time	Max value must larger than	5	ns
t_{FI}	Input Fall time	Max value must larger than	5	ns
t_{CKH}	SCK High Time	Min value must smaller than	20	ns
t_{CKL}	SCK Low Time	Min value must smaller than	20	ns
t_{CEH}	CE# High Time	Min value must smaller than	100	ns
t_{CS}	CE# Setup Time	Min value must smaller than	20	ns
t_{CH}	CE# Hold Time	Min value must smaller than	100	ns
t_{DS}	Data In Setup Time	Min value must smaller than	20	ns
t_{DH}	Data In Hold Time	Min value must smaller than	20	ns
t_{HS}	Hold Setup Time	Not Utilized		
t_{HD}	Hold Time	Not Utilized		
t_v	Output Valid	Max value must smaller than	20	ns
t_{OH}	Output Hold Time Normal Mode	Not Utilized		
t_{LZ}	Hold to Output Low Z	Not Utilized		
t_{HZ}	Hold to Output High Z	Not Utilized		
t_{DIS}	Output Disable Time	Not Utilized		
t_{EC}	Erase Time	Max value must smaller than	100	ms
t_{PP}	Page Program Time	Max value must smaller than	100	ms
t_{VCS}	Vcc Setup Time	Min value must smaller than	1	ms
t_w	Write Status Register Time (Flash bit)	Max value must smaller than	100	ms

*Fast read mode must be supported.

SERIAL INPUT/OUTPUT TIMING (1)

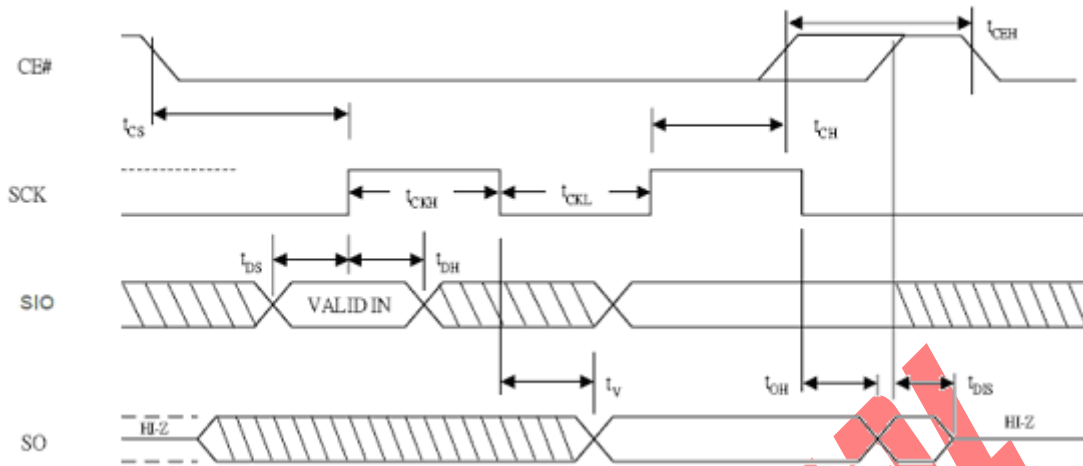

Figure 3 – Illustration of SPI Flash Interface Timing – (1)

HOLD TIMING

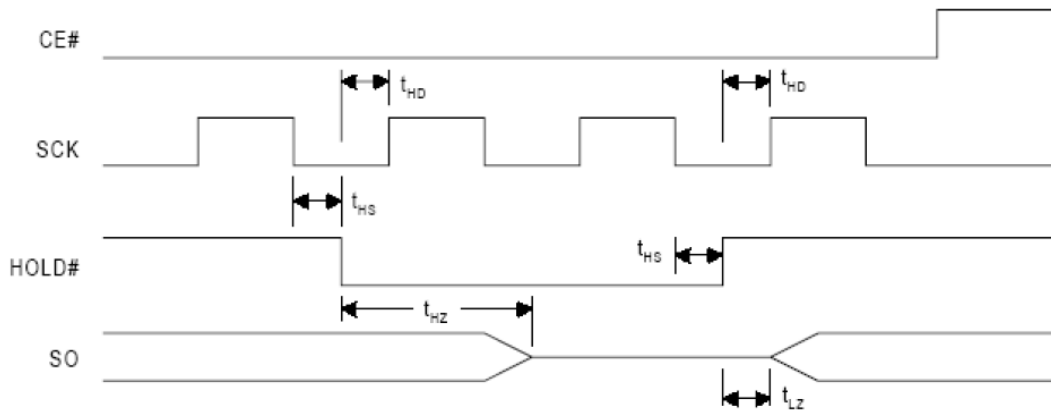
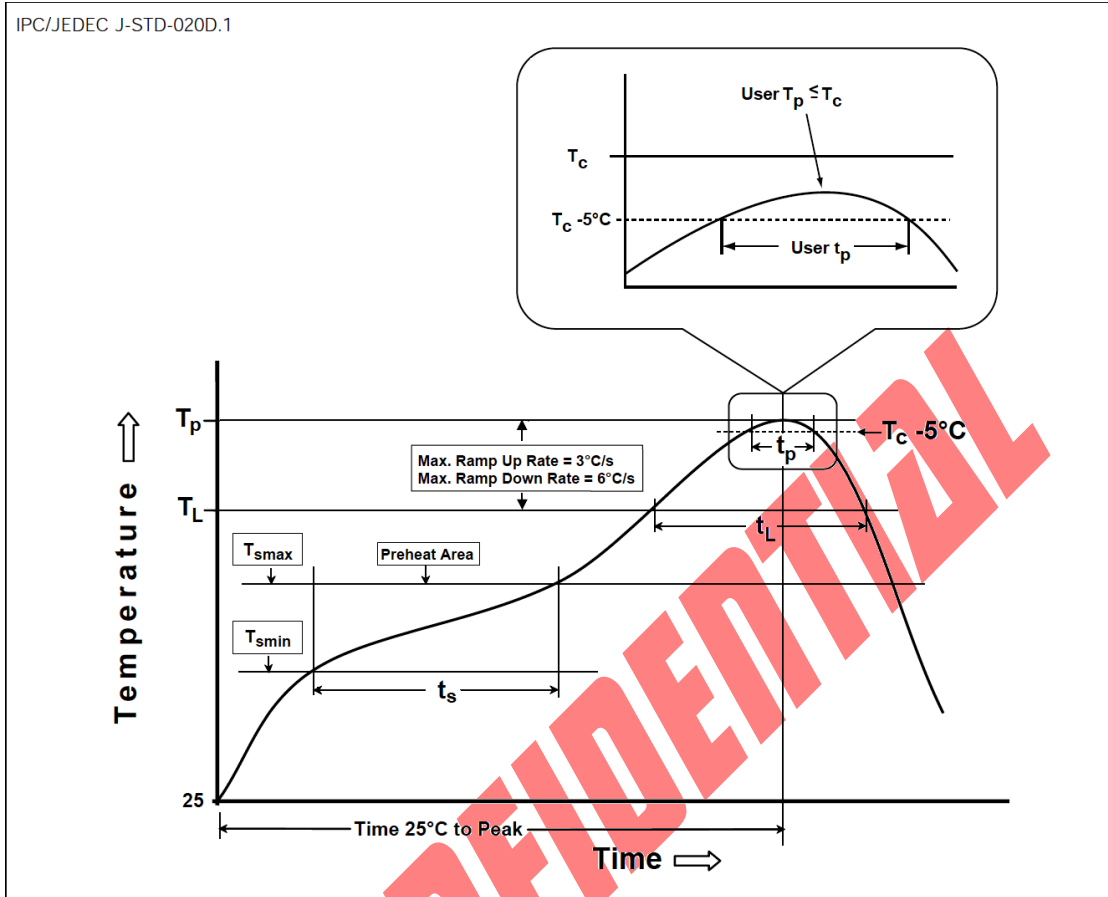

Figure 4 – Illustration of SPI Flash Interface Timing – (2)

General Reflow Profile Guidelines.



Profile Feature	Sn-Pb Eutectic Assembly	Pb-Free Assembly
Preheat/Soak		
Temperature Min (T_{smin})	100 °C	150 °C
Temperature Max (T_{smax})	150 °C	200 °C
Time (t_s) from (T_{smin} to T_{smax})	60-120 seconds	60-120 seconds
Ramp-up rate (T_L to T_p)	3 °C/second max.	3 °C/second max.
Liquidous temperature (T_L)	183 °C	217 °C
Time (t_L) maintained above T_L	60-150 seconds	60-150 seconds
Peak package body temperature (T_p)	225 °C	250 °C
Classification temperature (T_c)	230 °C	255 °C
Time (t_p)* within 5 °C of the specified classification temperature (T_c)	20* seconds	30* seconds
Ramp-down rate (T_p to T_L)	6 °C/second max.	6 °C/second max.
Time 25 °C to peak temperature	6 minutes max.	8 minutes max.

Note 1: All temperatures refer to the center of the package, measured on the package body surface that is facing up during assembly reflow (e.g., live-bug).

Figure 5 –Reflow

Package Mechanical Specifications

Maximum Temperature for IR Reflow

Parameter	Value	Unit
Maximum Temperature T_p	250	°C
Max Time within 5°C of T_p	30	seconds

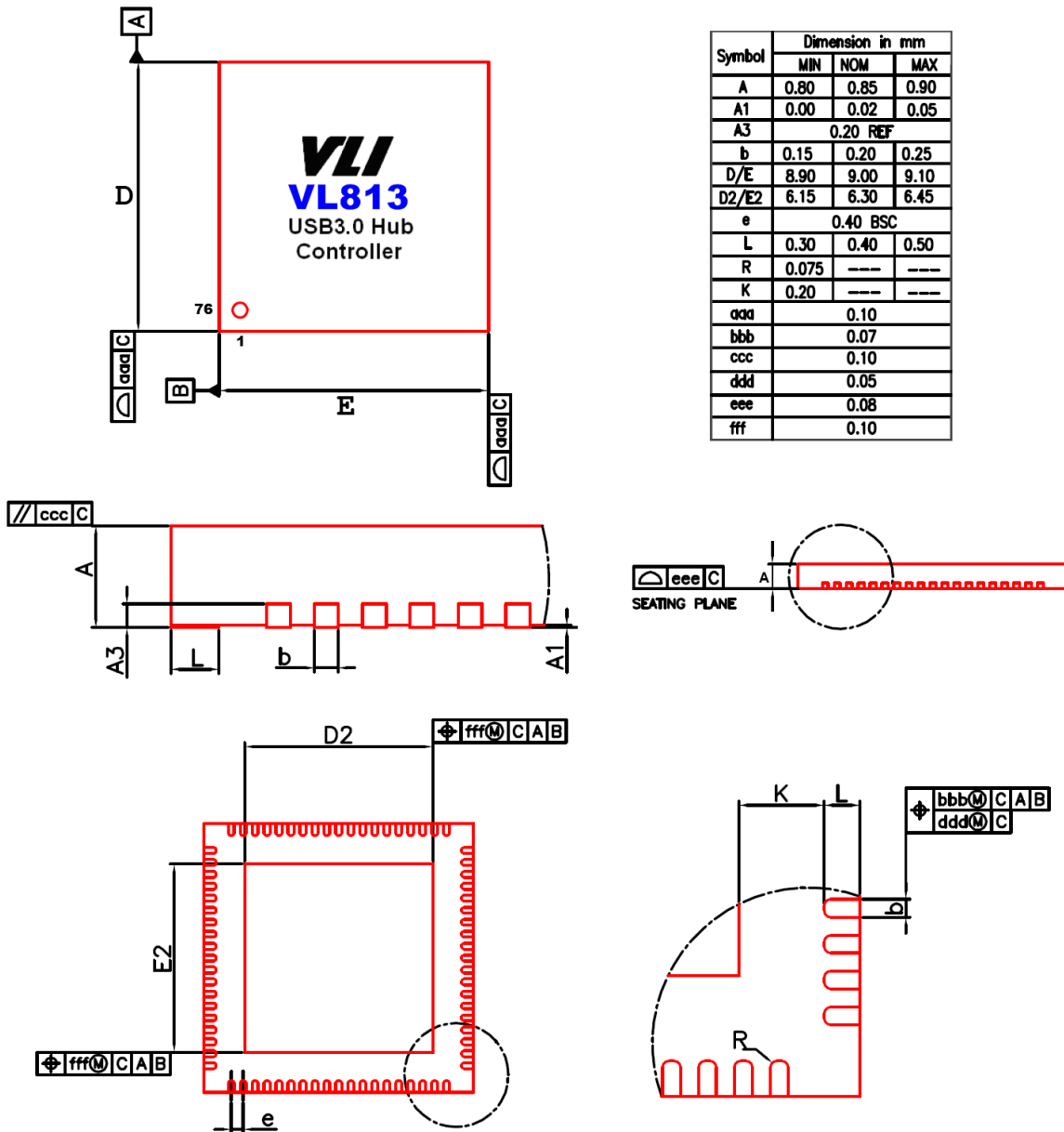

Figure 6 – Mechanical Specification – QFN 76L 9x9x0.85 mm Package

Package Top Side Marking & Ordering Information

Q7: QFN76 Package

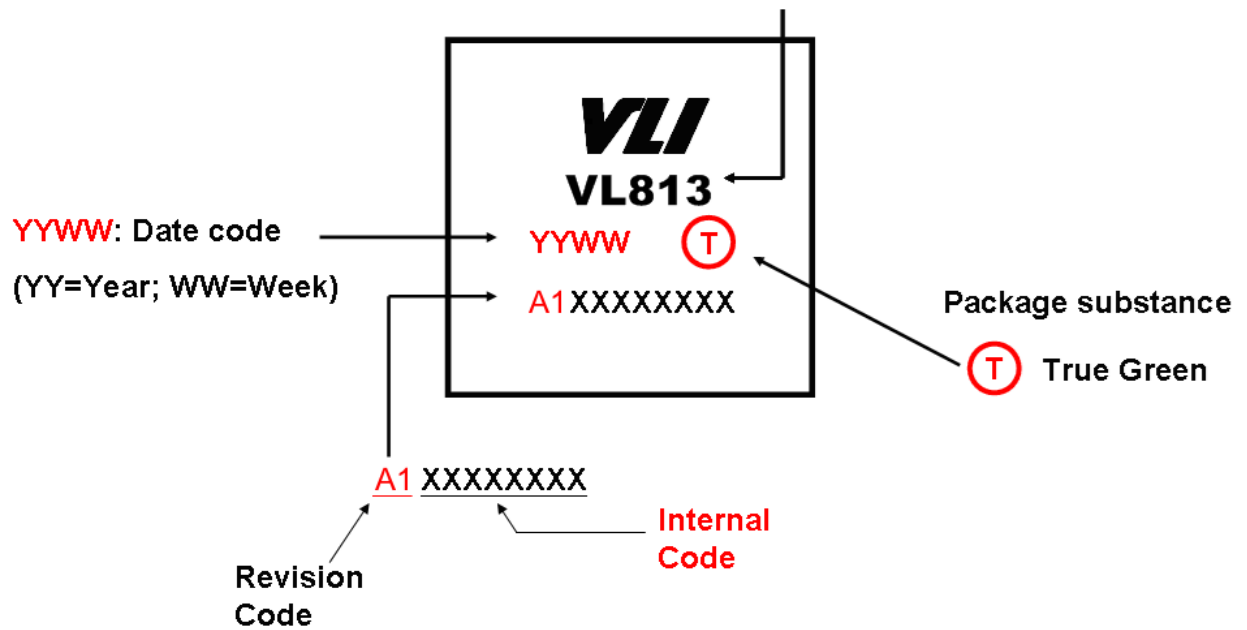

Figure 7 –Package Top Side Marking

Ordering Information	Description	Package Type
VL813 (A1)	Standard Configuration	QFN76 9x9 mm

VIA Labs, Inc.

www.via-labs.com

7F, 529-1, Zhongzheng Rd.,

Xindian District, New Taipei City 231 Taiwan

Tel: (886-2) 2218-1838

Fax: (886-2) 2218-8924

Email: sales@via-labs.com.tw

Copyright © 2013 VIA Labs, Inc. All Rights Reserved.

No part of this document may be reproduced, transmitted, transcribed, stored in a retrieval system, or translated into any language, in any form or by any means, electronic, mechanical, magnetic, optical, chemical, manual or otherwise without the prior written permission of VIA Labs, Inc. The material in this document is for information only and is subject to change without notice. VIA Labs, Inc. reserves the right to make changes in the product design without reservation and without notice to its users.

All trademarks are the properties of their respective owners.

No license is granted, implied or otherwise, under any patent or patent rights of VIA Labs, Inc. VIA Labs, Inc. makes no warranties, implied or otherwise, in regard to this document and to the products described in this document. The information provided by this document is believed to be accurate and reliable as of the publication date of this document. However, VIA Labs, Inc. assumes no responsibility for any errors in this document. Furthermore, VIA Labs, Inc. assumes no responsibility for the use or misuse of the information in this document and for any patent infringements that may arise from the use of this document. The information and product specifications within this document are subject to change at any time, without notice and without obligation to notify any person of such change.