

DIB .8 Amp Dual In-Line Bridge, Fast Recovery VM-X Series

For Fast Recovery Applications
 50V, 100V, 200V, 400V, 600V and 800V V_{RRM} Ratings
 25 Amps Peak One Half Cycle Surge Current
 Glass Passivated Diodes
 Standard .10" —2,54MM Dip Lead Spacing
 2 Dibs Will Fit Into Standard 14 Pin Dip Socket
 Moisture Resistant Epoxy Case

LTR.	INCHES	MILLIMETERS
A	.320-.335	8,13-8,51
B	.290-.310	7,37-7,87
C	.245-.255	6,22-6,48
D	.008-.012	0,20-0,30
E	.300-.350	7,62-8,89
F	.120-.130	3,05-3,30
G	.050-.080	1,27-2,03
H	.185-.215	4,70-5,46
I	.018-.022	0,46-0,56
J	.195-.205	4,95-5,21

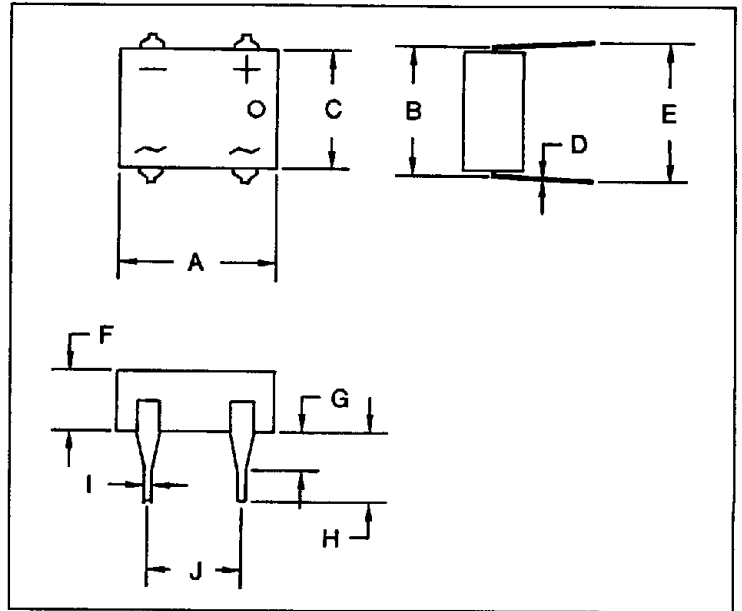

MAXIMUM RATINGS (At $T_A = 25^\circ\text{C}$ unless otherwise noted)

RATINGS	SYMBOL	VM08X	VM18X	VM28X	VM48X	VM68X	VM88X	VM108X
DC Blocking Voltage	V_{RM}							
Working Peak Reverse Voltage	V_{RWM}	50V	100V	200V	400V	600V	800V	1000V
Peak Repetitive Reverse Voltage	V_{RRM}							
RMS Reverse Voltage	$V_{R(RMS)}$	35V	70V	140V	280V	420V	560V	700V
Peak Surge Current, 1/2 cycle at 60 Hz (non-rep) and $T_A = 40^\circ\text{C}$	I_{FSM}	25 Amps						
DC Forward Current at $T_A = 40^\circ\text{C}$	I_O	800 mA						
Junction Operating and Storage Temperature Range	T_J, T_{STG}	- 50 to + 135°C						
Max. Soldering Time and Temperature		10 sec at 265°C						

ELECTRICAL CHARACTERISTICS (At $T_A = 25^\circ\text{C}$ unless otherwise noted)

CHARACTERISTICS	SYMBOL	
Maximum Instantaneous Forward Voltage Drop (per diode) at 800mA	V_{FM}	1.4V
Maximum Reverse Recovery Time $I_F = 1 \text{ Amp}, I_R = 2 \text{ Amp}$	t_r	200nSec
Maximum Reverse Current (per diode) at Rated V_{RRM}	I_{RM}	5.0 μA
Maximum Reverse Current (per diode) at Rated V_{RRM} and $T_A = 100^\circ\text{C}$	I_{RM}	0.5mA

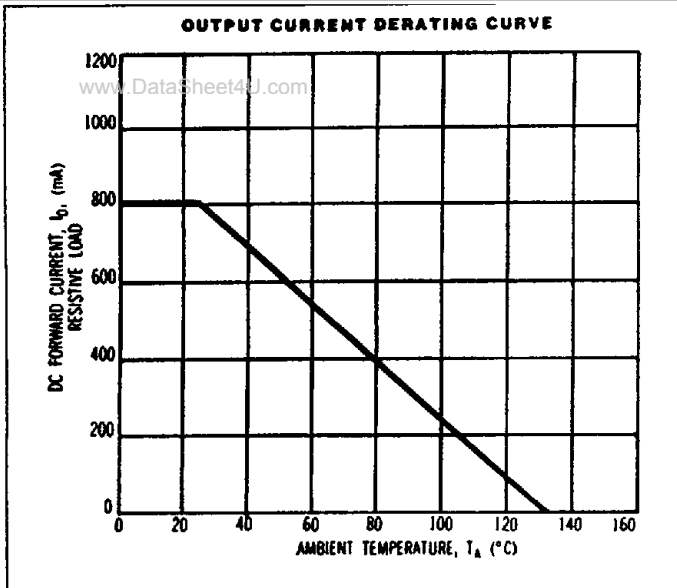

FIGURE 1

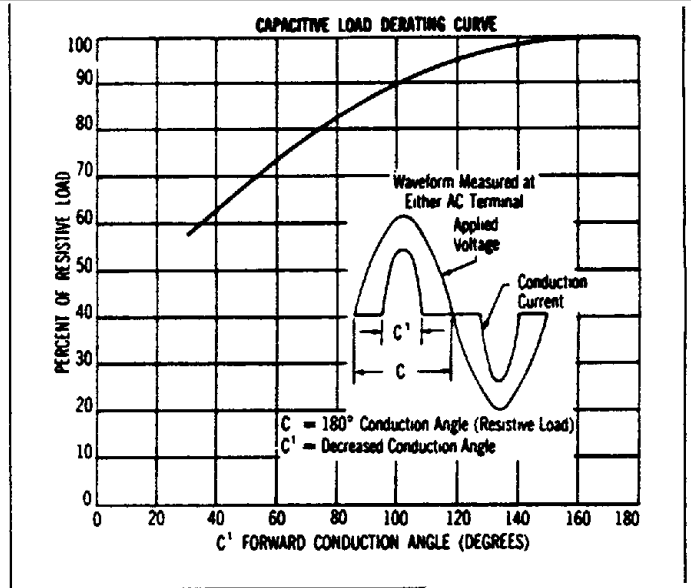

FIGURE 2

T-23-05

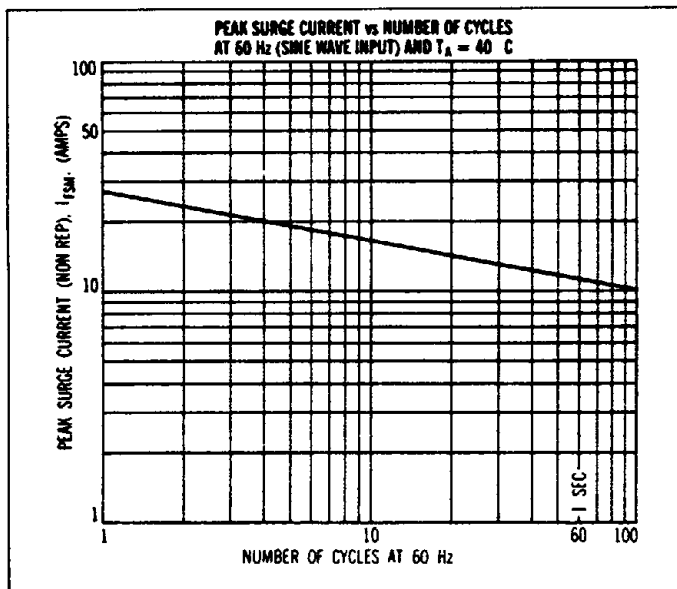

FIGURE 3

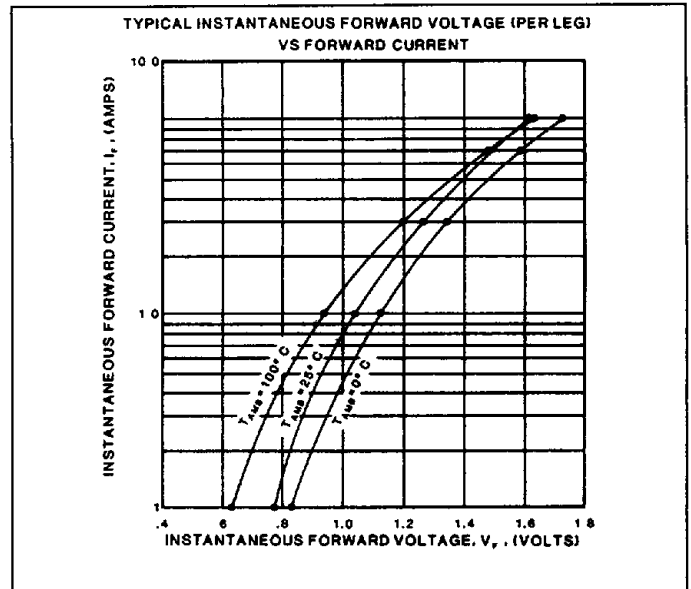

FIGURE 4

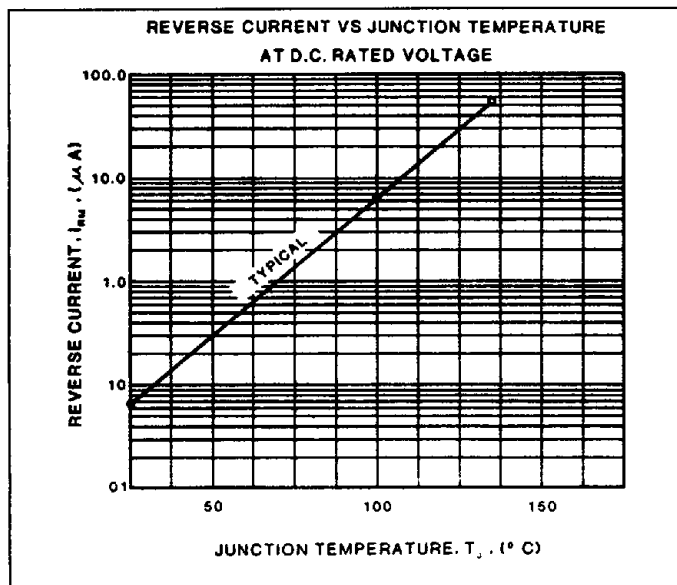

FIGURE 5

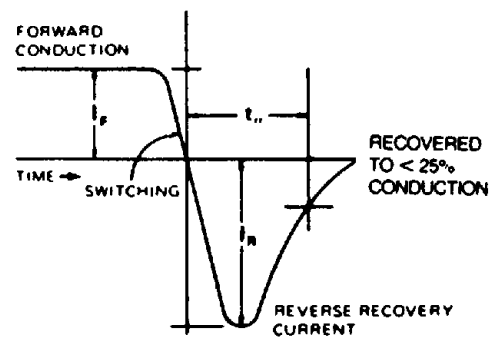

FIGURE 6