

GENERAL DESCRIPTION

Vesper presents the world's first piezoelectric MEMS microphone. The VM1000 provides superior performance and quality in all environments. The VM1000 is a low noise, high dynamic range, single-ended analog output piezoelectric MEMS microphone. This microphone consists of a piezoelectric sensor and circuitry to buffer and amplify the output.

The VM1000 has a small 3.76 mm X 2.95 mm X 1.1 mm package. This microphone is reflow solder compatible with no sensitivity degradation.



FEATURES

- Unique piezoelectric MEMS transducer
- Very-low noise floor
- Low part-to-part variation
- High dynamic range
- Stable performance in all conditions
- Dust and water resistant to IP57

APPLICATIONS

- Voice User Interface
- Beamforming Arrays
- Smart Home Devices
- Outdoor Applications
- Wearables

ORDERING INFORMATION

Product	Package Description	Quantity
VM1000-R13	13" Tape and Reel	5,000

BLOCK DIAGRAM

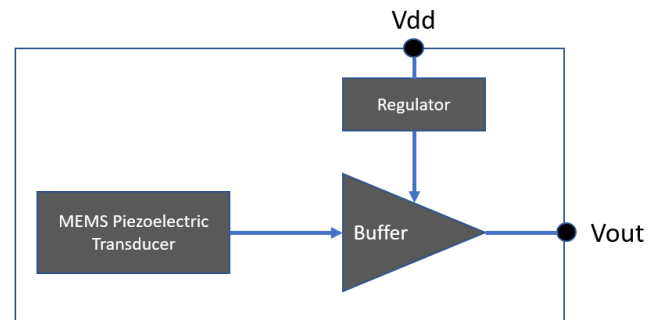

Functional Block Diagram

TYPICAL APPLICATION CIRCUIT

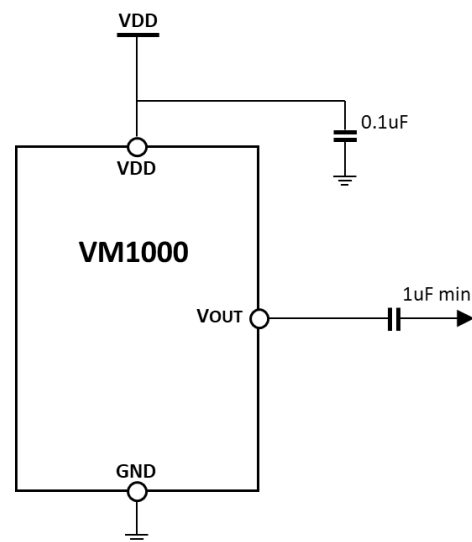

Typical Application Circuit

TABLE OF CONTENTS

SPECIFICATIONS	3
ABSOLUTE MAXIMUM RATINGS	4
ENVIRONMENTAL ROBUSTNESS	4
RELIABILITY SPECIFICATIONS	4
TYPICAL PERFORMANCE CHARACTERISTICS	5
SOLDER REFLOW PROFILE	5
HANDLING INSTRUCTIONS	5
DIMENSIONS AND PIN LAYOUT	6
PCB DESIGN AND LAND PATTERN LAYOUT	6
TAPE AND REEL SPECIFICATIONS	7
LID MARKING	7
SUPPORTING DOCUMENTS	8
COMPLIANCE INFORMATION	8
CONTACT DETAILS	8
LEGAL INFORMATION	8
REVISION HISTORY	9

SPECIFICATIONS

All specifications are at 25°C, VDD = 1.8 V unless otherwise noted

Parameter	Symbol	Conditions	Min.	Typ.	Max.	Units
Acoustic Specifications						
Sensitivity		1 kHz, 94 dB SPL	-41	-38	-35	dBV
Signal-to-Noise Ratio	SNR	94 dB SPL at 1 kHz signal, 20Hz to 20kHz, A-weighted Noise		62		dB(A)
Signal-to-Noise Ratio Voice Band	SNR	94 dB SPL at 1 kHz signal, 20Hz to 8kHz, A-weighted Noise		64		dB(A)
Total Harmonic Distortion	THD	94 dB SPL		0.1		%
Acoustic Overload Point	AOP	10.0% THD		127		dB SPL
Sensitivity Recovery Time After High SPL Event ¹		135 dB SPL for 50msec followed by 94 dB SPL		10		mS
Roll Off Frequency		-3dB at 1KHz		100		Hz
Directivity			Omni			
Polarity		Increase in sound pressure	Increase in output voltage			
Electrical Specifications						
Supply Voltage			1.6	1.8	3.6	V
Supply Current		V _{Supply} ≤ 3.6 V (TBR)		165		μA
Power Supply Rejection Ratio	PSRR	VDD = 1.8, 1kHz, 200mV _{PP} Sine wave		55		dB
Power Supply Rejection	PSR	VDD = 1.8, 217Hz, 100mV _{PP} square wave, 20 Hz – 20kHz, A-weighted		-85		dB(A)
Output Impedance	Z _{OUT}			400		Ω
Output DC Offset				0.8		V
Startup Time				200		μS

¹ Microphone is subjected to 135 dB SPL input at 1kHz for 50msec and then 94 dB SPL at 1kHz for measuring sensitivity recovery time. Recovery time is defined as the time taken for sensitivity to be within +1dB or -0.5dB of actual sensitivity.

ABSOLUTE MAXIMUM RATINGS

Parameter	Rating	Units
Supply Voltage	-0.3 to +3.6	V
Sound Pressure Level	160	dB re 20 μ Pa
Operating Temperature Range	-40 to +85	$^{\circ}$ C
Storage Temperature Range	-55 to +150	$^{\circ}$ C
Mechanical Shock	10,000g per IEC 60028-2-27:2008	
Vibration	Per MIL-STD 883E, 2007.2	

ENVIRONMENTAL ROBUSTNESS

IP adherence is evaluated by 1kHz Sensitivity spec post stress

Ingress Protection Type	Description
Dust Resistance	IP5X;
Water Immersion	IPX7; 2 hrs drying time, dry environment

RELIABILITY SPECIFICATIONS

Stress Test	Description
Temperature Cycling Test	-40 $^{\circ}$ C to +125 $^{\circ}$ C, 850 cycles
High Temperature Operating Life	+125 $^{\circ}$ C, 1000 hours, biased
High Temperature Storage	+125 $^{\circ}$ C, 1000 hours, unbiased
Temperature Humidity Bias	+85 $^{\circ}$ C, 85% RH, 1000 hours, biased
Reflow	3 reflow cycles with peak temperature of +260 $^{\circ}$ C
ESD-HBM	3 discharges, all pins, \pm 2kV
ESD-CDM	3 discharges, all pins, \pm 800V
ESD-LID/GND	3 discharges to lid, \pm 8kV
ESD-MM	3 discharges, all pins, \pm 200V
ESD-Air Discharge	3 discharges, \pm 15kV

TYPICAL PERFORMANCE CHARACTERISTICS

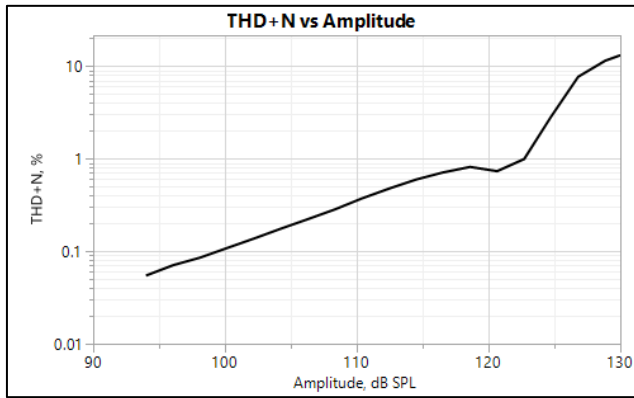

THD+N vs Amplitude

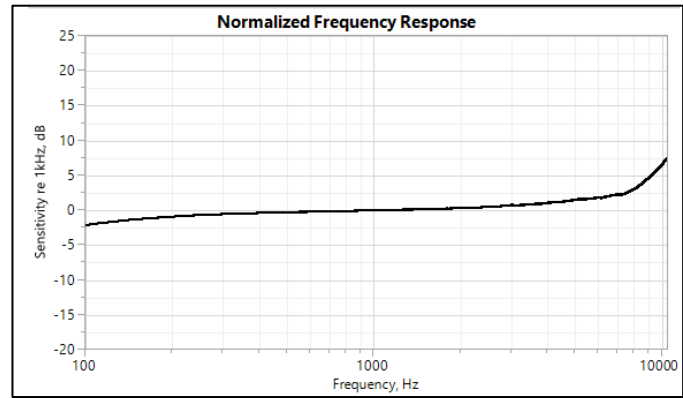

Normalized Frequency Response

SOLDER REFLOW PROFILE

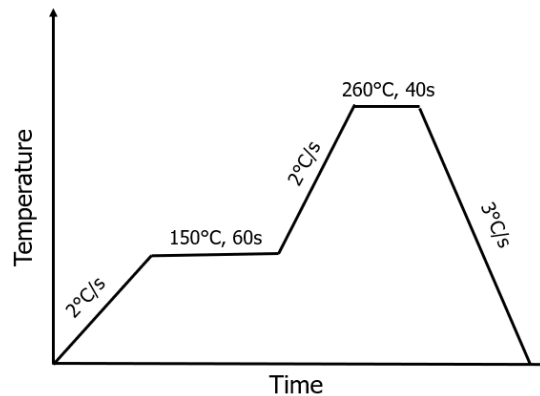

Solder Reflow Profile

HANDLING INSTRUCTIONS

The Piezo MEMS microphone is very robust to harsh environments such as dust and moisture. However, to avoid mechanical damage to the mic we recommend using appropriate handling procedures when manually handling the parts or when using pick and place equipment. The following guidelines will avoid damage:

- Do not apply a vacuum to the bottom side of the microphone. A vacuum pen may be used with care on the top side only.
- Do not apply very high air pressure over the port hole.
- Do not insert any large particles or objects in the port hole. The microphone is robust to small particles per IP5x specification.
- Do not board wash or clean after the reflow process or expose the acoustic port to harsh chemicals.

DIMENSIONS AND PIN LAYOUT

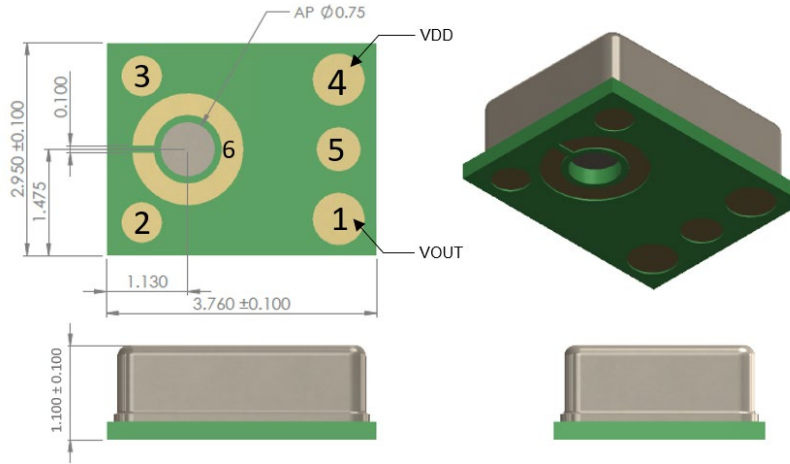

Pin Number	Pin Name	Description
1	V _{OUT}	Analog Output Voltage
2	GND	Ground
3	GND	Ground
4	V _{DD}	Power Supply
5	GND	Ground
6	GND	Ground

PCB DESIGN AND LAND PATTERN LAYOUT

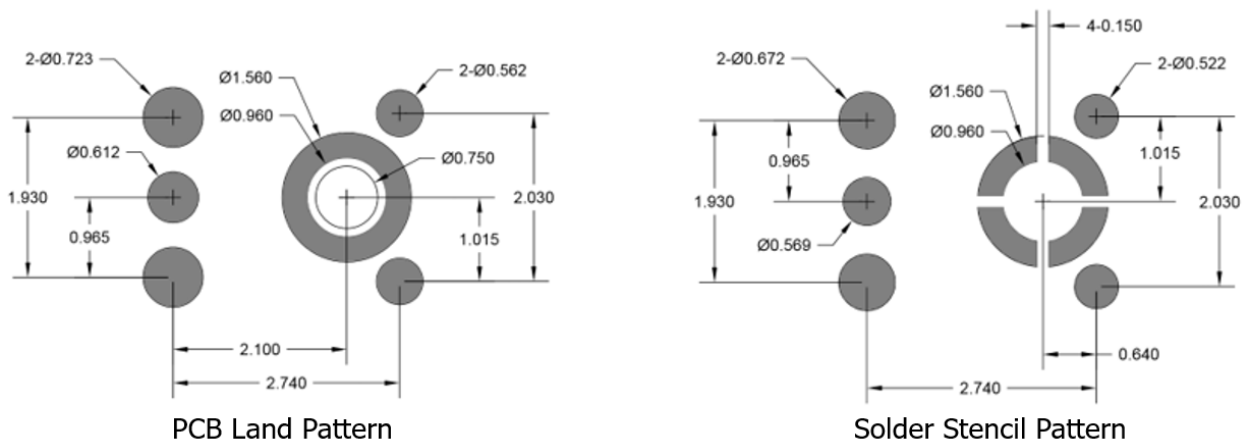

PCB and Solder Stencil Pattern – All Dimensions are in mm

TAPE AND REEL SPECIFICATIONS

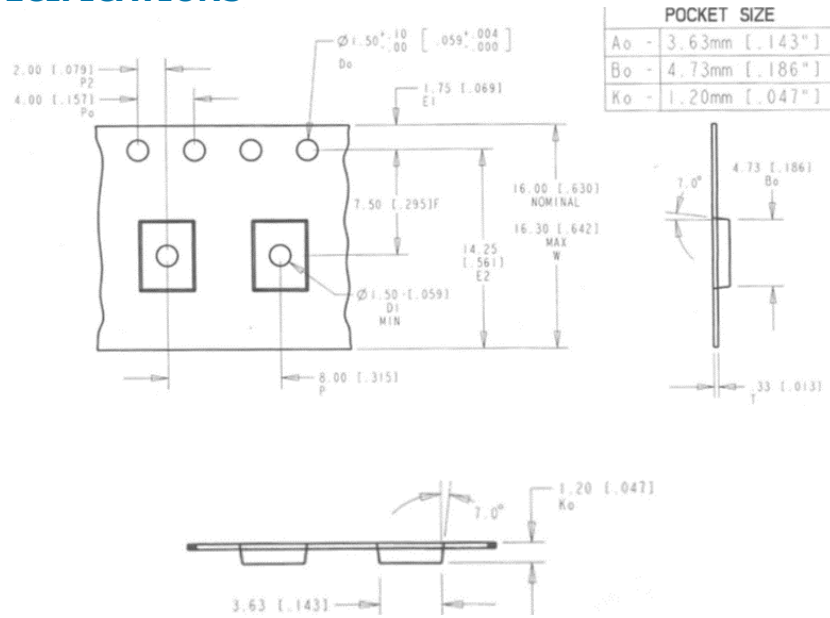

Tape and Reel specification - All dimensions in millimeters (inches)

LID MARKING

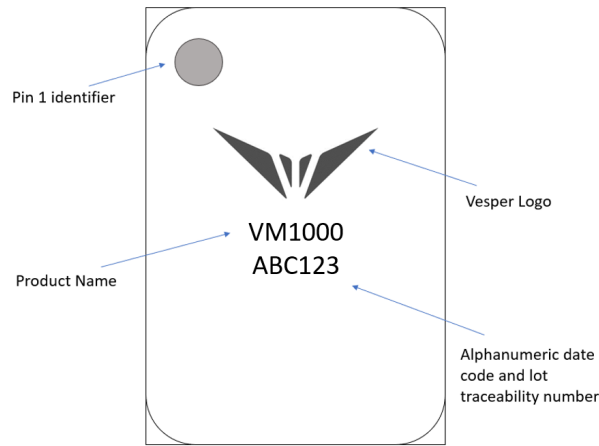

Lid Marking Description

SUPPORTING DOCUMENTS

VM1000_Coupon_PCB_UserGuide - Vesper VM1000 Coupon PCB board user guide

VM1000_3D_Model – Vesper VM1000 3D CAD Layout

AN3 – Vesper Piezoelectric MEMS Microphone Assembly Guidelines

COMPLIANCE INFORMATION

Electrostatic discharge (ESD) sensitive device:

Although this product features industry standard protection circuitry, damage may occur if subjected to excessive ESD. Proper ESD precautions should be taken to avoid damage to the device.



CONTACT DETAILS

Vesper Technologies
77 Summer St Floor 8
Boston, MA 02110
Email: info@vespermems.com

LEGAL INFORMATION

For any questions or comments on the datasheet email: erratum@vespermems.com

Information furnished by Vesper is believed to be accurate and reliable. However, no responsibility is assumed by Vesper for its use, nor for any infringements of patents or other rights of third parties that may result from its use. Specifications subject to change without notice. No license is granted by implication or otherwise under any patent or patent rights of Vesper. Trademarks and registered trademarks are the property of their respective owners.

REVISION HISTORY

Revision	Date	Description
0.0.0	02/22/2019	Initial Revision