



VND5E012MY-E

Double channel high-side driver with analog current sense for automotive applications

Features

Max transient supply voltage	V_{CC}	41V
Operating voltage range	V_{CC}	4.5 to 28V
Max on-state resistance (per ch.)	R_{ON}	12 m Ω
Current limitation (typ)	I_{LIMH}	74 A
Off-state supply current	I_S	2 μ A ⁽¹⁾

1. Typical value with all loads connected.

■ General

- Inrush current active management by power limitation
- Very low standby current
- 3.0V CMOS compatible inputs
- Optimized electromagnetic emissions
- Very low electromagnetic susceptibility
- In compliance with the 2002/95/EC european directive
- Very low current sense leakage

■ Diagnostic functions

- Proportional load current sense
- High current sense precision for wide current range
- Current sense disable
- Overload and short to ground (power limitation) indication
- Thermal shutdown indication

■ Protections

- Undervoltage shutdown
- Overvoltage clamp
- Load current limitation
- Self limiting of fast thermal transients
- Protection against loss of ground and loss of V_{CC}
- Overtemperature shutdown with auto restart (thermal shutdown)



- Reverse battery protection with self switch on of the Power MOSFET (see [Figure 29](#))
- Electrostatic discharge protection

Applications

- All types of resistive, inductive and capacitive loads
- Suitable as LED driver

Description

The VND5E012MY-E is a double channel high-side driver manufactured in the ST proprietary VIPower™ M0-5 technology and housed in the tiny PowerSSO-36 package. The VND5E012MY-E is designed to drive 12V automotive grounded loads delivering protection, diagnostics and easy 3V and 5V CMOS compatible interface with any microcontroller.

The device integrates advanced protective functions such as load current limitation, inrush and overload active management by power limitation, overtemperature shut-off with auto restart and over-voltage active clamp. A dedicated analog current sense pin is associated with every output channel in order to provide *Enhanced* diagnostic functions including fast detection of overload and short-circuit to ground through power limitation indication and overtemperature indication.

The current sensing and diagnostic feedback of the whole device can be disabled by pulling the CS_DIS pin high to allow sharing of the external sense resistor with other similar devices.

Contents

1	Block diagram and pin description	5
2	Electrical specifications	7
2.1	Absolute maximum ratings	7
2.2	Thermal data	8
2.3	Electrical characteristics	9
2.4	Waveforms	17
2.5	Electrical characteristics curves	19
3	Application information	22
3.1	Load dump protection	22
3.2	MCU I/Os protection	22
3.3	Current sense and diagnostic	23
3.4	Maximum demagnetization energy (VCC = 13.5V)	25
4	Package and PCB thermal data	26
4.1	PowerSSO-36 thermal data	26
5	Package information	29
5.1	ECOPACK [®] package	29
5.2	PowerSSO-36 mechanical data	29
5.3	Packing information	31
6	Order codes	32
7	Revision history	33

List of tables

Table 1.	Pin function	5
Table 2.	Suggested connections for unused and not connected pins	6
Table 3.	Absolute maximum rating	7
Table 4.	Thermal data	8
Table 5.	Power section	9
Table 6.	Switching ($V_{CC} = 13V$; $T_j = 25^{\circ}C$)	9
Table 7.	Logic inputs	10
Table 8.	Protections and diagnostics	10
Table 9.	Current sense ($8V < V_{CC} < 18V$)	11
Table 10.	Truth table	15
Table 11.	Electrical transient requirements (part 1)	16
Table 12.	Electrical transient requirements (part 2)	16
Table 13.	Electrical transient requirements (part 3)	16
Table 14.	Thermal parameter	28
Table 15.	PowerSSO-36 mechanical data	30
Table 16.	Device summary	32
Table 17.	Document revision history	33

List of figures

Figure 1.	Block diagram	5
Figure 2.	Configuration diagram (top view)	6
Figure 3.	Current and voltage conventions	7
Figure 4.	Current sense delay characteristics	12
Figure 5.	Switching characteristics	12
Figure 6.	Delay response time between rising edge of output current and rising edge of current sense (CS enabled)	13
Figure 7.	Output voltage drop limitation	13
Figure 8.	I_{OUT}/I_{SENSE} vs I_{OUT}	14
Figure 9.	Maximum current sense ratio drift vs load current	14
Figure 10.	Normal operation	17
Figure 11.	Overload or short to GND	17
Figure 12.	Intermittent overload	18
Figure 13.	T_J evolution in overload or short to GND	18
Figure 14.	Off-state output current	19
Figure 15.	High level input current	19
Figure 16.	Input clamp voltage	19
Figure 17.	Input high level voltage	19
Figure 18.	Input low level voltage	19
Figure 19.	Input hysteresis voltage	19
Figure 20.	On-state resistance vs T_{case}	20
Figure 21.	On-state resistance vs V_{CC}	20
Figure 22.	Undervoltage shutdown	20
Figure 23.	I_{LIMH} vs T_{case}	20
Figure 24.	Turn-on voltage slope	20
Figure 25.	Turn-off voltage slope	20
Figure 26.	CS_DIS clamp voltage	21
Figure 27.	Low level CS_DIS voltage	21
Figure 28.	High level CS_DIS voltage	21
Figure 29.	Application schematic	22
Figure 30.	Current sense and diagnostic	24
Figure 31.	Maximum turn-off current versus inductance	25
Figure 32.	PowerSSO-36 PC board	26
Figure 33.	$R_{thj-amb}$ vs PCB copper area in open box free air condition (one channel ON)	27
Figure 34.	PowerSSO-36 thermal impedance junction ambient single pulse (one channel ON)	27
Figure 35.	Thermal fitting model of a double channel HSD in PowerSSO-36 ⁽¹⁾	28
Figure 36.	PowerSSO-36 package dimensions	29
Figure 37.	PowerSSO-36 tube shipment (no suffix)	31
Figure 38.	PowerSSO-36 tape and reel shipment (suffix "TR")	31

1 Block diagram and pin description

Figure 1. Block diagram

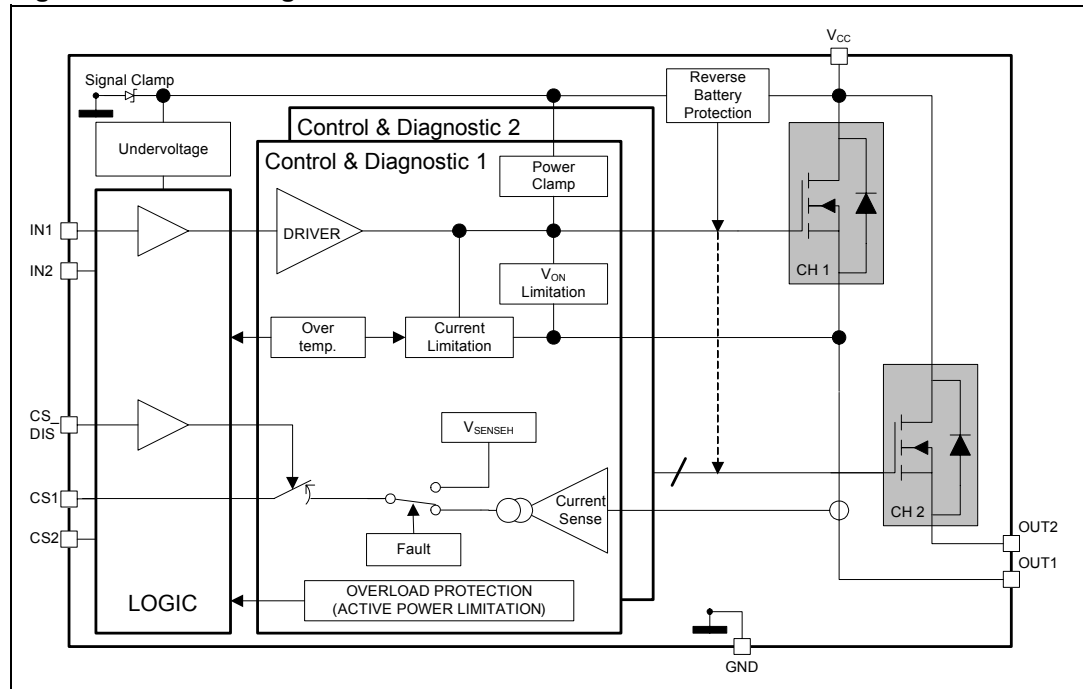


Table 1. Pin function

Name	Function
V_{CC}	Battery connection
OUT _{1,2}	Power output
GND	Ground connection
IN _{1,2}	Voltage controlled input pin with hysteresis, CMOS compatible. Controls output switch state
CS _{1,2}	Analog current sense pin, delivers a current proportional to the load current
CS_DIS	Active high CMOS compatible pin, to disable the current sense pin

Figure 2. Configuration diagram (top view)

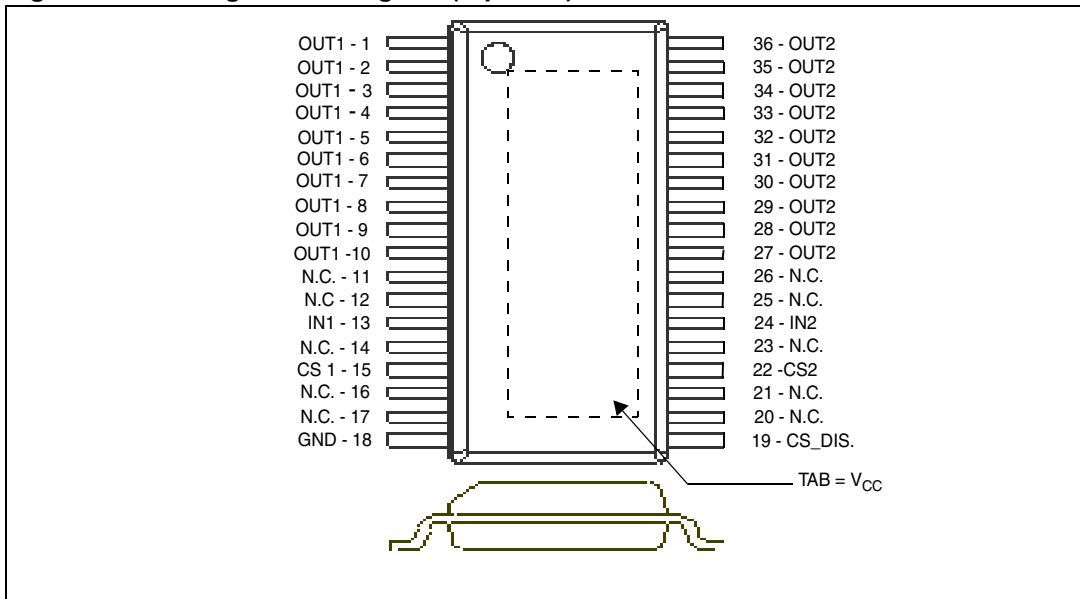
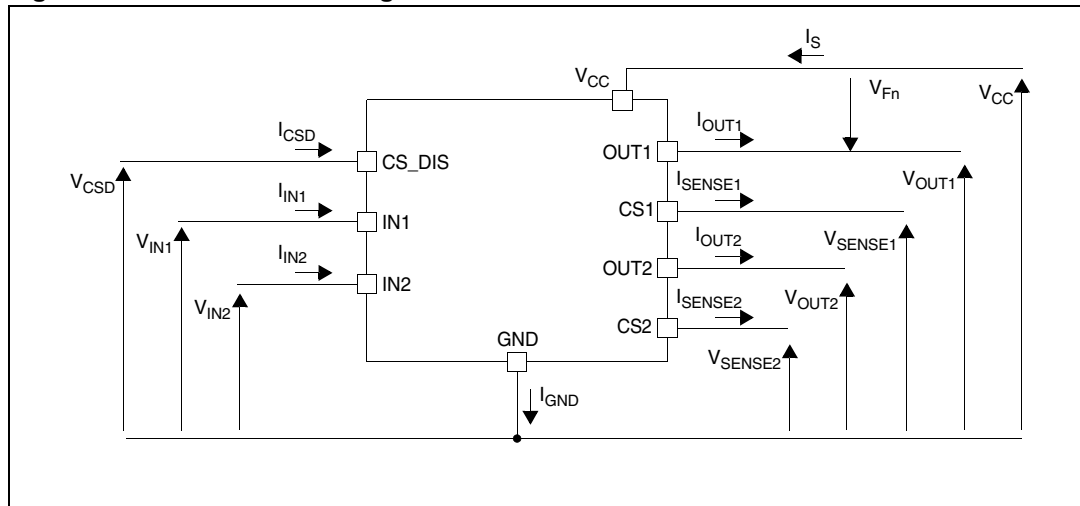


Table 2. Suggested connections for unused and not connected pins

Connection / pin	Current Sense	N.C.	Output	Input	CS_DIS
Floating	Not allowed	X	X	X	X
To ground	Through 1 KΩ resistor	X	Not allowed	Through 10 KΩ resistor	Through 10 KΩ resistor

2 Electrical specifications

Figure 3. Current and voltage conventions



2.1 Absolute maximum ratings

Stressing the device above the rating listed in the “Absolute maximum ratings” table may cause permanent damage to the device. These are stress ratings only and operation of the device at these or any other conditions above those indicated in the Operating sections of this specification is not implied. Exposure to the conditions in table below for extended periods may affect device reliability. Refer also to the STMicroelectronics SURE Program and other relevant quality document.

Table 3. Absolute maximum rating

Symbol	Parameter	Value	Unit
V_{CC}	DC supply voltage	28	V
V_{CCPK}	Transient supply voltage ($T < 400\text{ms}$, $R_{LOAD} > 0.5\Omega$)	41	V
$-V_{CC}$	Reverse DC supply voltage	16	V
V_{CC_LSC}	Maximum supply voltage for full protection to short-circuit (acc. AEC-Q100-012)	18	V
I_{OUT}	DC output current	Internally limited	A
$-I_{OUT}$	Reverse DC output current	50	A
I_{IN}	DC input current	-1 to 10	mA
I_{CSD}	DC current sense disable input current	-1 to 10	mA
V_{CSENSE}	Current sense maximum voltage	$V_{CC}-41$ $+V_{CC}$	V V
E_{MAX}	Maximum switching energy (single pulse) ($L = 0.47\text{ mH}$; $R_L = 0\ \Omega$; $V_{bat} = 13.5\text{ V}$; $T_{jstart} = 150\text{ }^\circ\text{C}$; $I_{OUT} = I_{limL}(\text{Typ.})$)	110	mJ

Table 3. Absolute maximum rating (continued)

Symbol	Parameter	Value	Unit
V _{ESD}	Electrostatic discharge (Human Body Model: R=1.5KΩ; C=100pF)		
	– V _{CC} , OUTPUT	5000	V
	– INPUT, CS_DIS – CURRENT SENSE	4000 2000	
V _{ESD}	Charge device model (CDM-AEC-Q100-011)	750	V
T _j	Junction operating temperature	-40 to 150	°C
T _{stg}	Storage temperature	-55 to 150	°C

2.2 Thermal data

Table 4. Thermal data

Symbol	Parameter	Max. value	Unit
R _{thj-case}	Thermal resistance junction-case (MAX) (with one channel ON)	2	°C/W
R _{thj-amb}	Thermal resistance junction-ambient (MAX)	See Figure 33 in the Thermal section	°C/W

2.3 Electrical characteristics

Values specified in this section are for $8V < V_{CC} < 28V$; $-40^{\circ}C < T_j < 150^{\circ}C$, unless otherwise specified.

Table 5. Power section

Symbol	Parameter	Test conditions	Min.	Typ.	Max.	Unit
V_{CC}	Operating supply voltage		4.5	13	28	V
V_{USD}	Undervoltage shutdown			3.5	4.5	V
$V_{USDhyst}$	Undervoltage shutdown hysteresis			0.5		V
R_{ON}	On-state resistance	$I_{OUT} = 5A$; $T_j = 25^{\circ}C$ $I_{OUT} = 5A$; $T_j = 150^{\circ}C$ $I_{OUT} = 5A$; $V_{CC} = 5V$; $T_j = 25^{\circ}C$		11	24 16	$m\Omega$ $m\Omega$ $m\Omega$
$R_{ON REV}$	Reverse battery on-state resistance	$V_{CC} = -13V$; $I_{OUT} = -5A$; $T_j = 25^{\circ}C$			12	$m\Omega$
V_{clamp}	Clamp voltage	$I_S = 20 mA$	41	46	52	V
I_S	Supply current	Off-state; $V_{CC} = 13V$; $T_j = 25^{\circ}C$; $V_{IN} = V_{OUT} = V_{SENSE} = V_{CSD} = 0V$ On-state; $V_{CC} = 13V$; $V_{IN} = 5V$; $I_{OUT} = 0A$		2 ⁽¹⁾ 3.5	5 ⁽¹⁾ 6.5	μA mA
$I_{L(off)}$	Off-state output current ⁽²⁾	$V_{IN} = V_{OUT} = 0V$; $V_{CC} = 13V$; $T_j = 25^{\circ}C$ $V_{IN} = V_{OUT} = 0V$; $V_{CC} = 13V$; $T_j = 125^{\circ}C$	0 0	0.01	3 5	μA

1. PowerMOS leakage included.

2. For each channel.

Table 6. Switching ($V_{CC} = 13V$; $T_j = 25^{\circ}C$)

Symbol	Parameter	Test conditions	Min.	Typ.	Max.	Unit
$t_{d(on)}$	Turn-on delay time	$R_L = 2.6\Omega$ (see Figure 5)	-	30	-	μs
$t_{d(off)}$	Turn-off delay time	$R_L = 2.6\Omega$ (see Figure 5)	-	20	-	μs
$(dV_{OUT}/dt)_{on}$	Turn-on voltage slope	$R_L = 2.6\Omega$	-	See Figure 24	-	$V/\mu s$
$(dV_{OUT}/dt)_{off}$	Turn-off voltage slope	$R_L = 2.6\Omega$	-	See Figure 25	-	$V/\mu s$
W_{ON}	Switching energy losses during t_{WON}	$R_L = 2.6\Omega$ (see Figure 5)	-	1	-	mJ
W_{OFF}	Switching energy losses during t_{WOFF}	$R_L = 2.6\Omega$ (see Figure 5)	-	0.5	-	mJ

Electrical specifications

VND5E012MY-E

Table 7. Logic inputs

Symbol	Parameter	Test conditions	Min.	Typ.	Max.	Unit
V_{IL}	Input low level voltage				0.9	V
I_{IL}	Low level input current	$V_{IN} = 0.9V$	1			μA
V_{IH}	Input high level voltage		2.1			V
I_{IH}	High level input current	$V_{IN} = 2.1V$			10	μA
$V_{I(hyst)}$	Input hysteresis voltage		0.25			V
V_{ICL}	Input clamp voltage	$I_{IN} = 1mA$ $I_{IN} = -1mA$	5.5	-0.7	7	V V
V_{CSDL}	CS_DIS low level voltage				0.9	V
I_{CSDL}	Low level CS_DIS current	$V_{CSD} = 0.9V$	1			μA
V_{CSDH}	CS_DIS high level voltage		2.1			V
I_{CSDH}	High level CS_DIS current	$V_{CSD} = 2.1V$			10	μA
$V_{CSD(hyst)}$	CS_DIS hysteresis voltage		0.25			V
V_{CSCL}	CS_DIS clamp voltage	$I_{CSD} = 1mA$ $I_{CSD} = -1mA$	5.5	-0.7	7	V V

Table 8. Protections and diagnostics (1)

Symbol	Parameter	Test conditions	Min.	Typ.	Max.	Unit
I_{limH}	DC short circuit current	$V_{CC} = 13V$ $5V < V_{CC} < 18V$	52	74	104 104	A A
I_{limL}	Short circuit current during thermal cycling	$V_{CC} = 13V$; $T_R < T_j < T_{TSD}$		18.5		A
T_{TSD}	Shutdown temperature		150	175	200	$^{\circ}C$
T_R	Reset temperature		$T_{RS} + 1$	$T_{RS} + 5$		$^{\circ}C$
T_{RS}	Thermal reset of status		135			$^{\circ}C$
T_{HYST}	Thermal hysteresis ($T_{TSD} - T_R$)			7		$^{\circ}C$
V_{DEMAG}	Turn-off output voltage clamp	$I_{OUT} = 2A$; $V_{IN} = 0$; $L = 6mH$	$V_{CC} - 28$	$V_{CC} - 31$	$V_{CC} - 35$	V
V_{ON}	Output voltage drop limitation	$I_{OUT} = 0.4A$; $T_j = -40^{\circ}C \dots 150^{\circ}C$ (see Figure 7)		25		mV

1. To ensure long term reliability under heavy overload or short circuit conditions, protection and related diagnostic signals must be used together with a proper software strategy. If the device is subjected to abnormal conditions, this software must limit the duration and number of activation cycles.

Table 9. Current sense (8V<V_{CC}<18V)

Symbol	Parameter	Test conditions	Min.	Typ.	Max.	Unit
K ₀	I _{OUT} /I _{SENSE}	I _{OUT} =0.25A; V _{SENSE} =0.5V T _J = -40°C...150°C	2615	5130	7770	
K ₁	I _{OUT} /I _{SENSE}	I _{OUT} =5A; V _{SENSE} =0.5V T _J =-40°C...150°C T _J =25°C...150°C	4155 4530	5330 5330	6650 6130	
dK ₁ /K ₁ ⁽¹⁾	Current sense ratio drift	I _{OUT} =5A; V _{SENSE} = 0.5V; V _{CSD} =0V; T _J = -40 °C to 150 °C	-8		8	%
K ₂	I _{OUT} /I _{SENSE}	I _{OUT} =10A; V _{SENSE} =4V T _J =-40°C...150°C T _J =25°C...150°C	4705 4865	5290 5290	5950 5715	
dK ₂ /K ₂ ⁽¹⁾	Current sense ratio drift	I _{OUT} = 10 A; V _{SENSE} = 4 V; V _{CSD} =0V; T _J = -40 °C to 150 °C	-5		5	%
K ₃	I _{OUT} /I _{SENSE}	I _{OUT} =25A; V _{SENSE} =4V T _J =-40°C...150°C T _J =25°C...150°C	4935 4985	5250 5250	5565 5515	
dK ₃ /K ₃ ⁽¹⁾	Current sense ratio drift	I _{OUT} = 25 A; V _{SENSE} = 4 V; V _{CSD} = 0V; T _J = -40 °C to 150 °C	-4		4	%
I _{SENSE0}	Analog sense leakage current	I _{OUT} =0A; V _{SENSE} =0V; V _{CSD} =5V; V _{IN} =0V; T _J =-40°C...150°C	0		1	μA
		V _{CSD} =0V; V _{IN} =5V; T _J =-40°C...150°C	0		2	μA
		I _{OUT} =5A; V _{SENSE} =0V; V _{CSD} =V _{IN} =5V;	0		1	μA
V _{SENSE}	Max analog sense output voltage	I _{OUT} =15A; V _{CSD} =0V	5			V
V _{SENSEH}	Analog sense output voltage in fault condition ⁽²⁾	V _{CC} =13V; R _{SENSE} =10KΩ		8		V
I _{SENSEH}	Analog sense output current in fault condition ⁽²⁾	V _{CC} =13V; V _{SENSE} =5V		9		mA
t _{DSENSE1H}	Delay response time from falling edge of CS_DIS pin	V _{SENSE} <4V, 1.5A<I _{OUT} <25A I _{SENSE} =90% of I _{SENSE max} (see Figure 4)		50	100	μs
t _{DSENSE1L}	Delay response time from rising edge of CS_DIS pin	V _{SENSE} <4V, 1.5A<I _{OUT} <25A I _{SENSE} =10% of I _{SENSE max} (see Figure 4)		5	20	μs

Table 9. Current sense (8V<V_{CC}<18V) (continued)

Symbol	Parameter	Test conditions	Min.	Typ.	Max.	Unit
t_{DSENSE2H}	Delay response time from rising edge of INPUT pin	$V_{\text{SENSE}} < 4\text{V}$, $1.5\text{A} < I_{\text{OUT}} < 25\text{A}$ $I_{\text{SENSE}} = 90\%$ of $I_{\text{SENSE max}}$ (see Figure 4)		70	300	μs
$\Delta t_{\text{DSENSE2H}}$	Delay response time between rising edge of output current and rising edge of current sense	$V_{\text{SENSE}} < 4\text{V}$, $I_{\text{SENSE}} = 90\%$ of I_{SENSEMAX} , $I_{\text{OUT}} = 90\%$ of I_{OUTMAX} $I_{\text{OUTMAX}} = 5\text{A}$ (see Figure 6)			300	μs
t_{DSENSE2L}	Delay response time from falling edge of INPUT pin	$V_{\text{SENSE}} < 4\text{V}$, $1.5\text{A} < I_{\text{OUT}} < 25\text{A}$ $I_{\text{SENSE}} = 10\%$ of $I_{\text{SENSE max}}$ (see Figure 4)		100	250	μs

1. Parameter guaranteed by design; it is not tested.
2. Fault condition includes: power limitation and overtemperature.

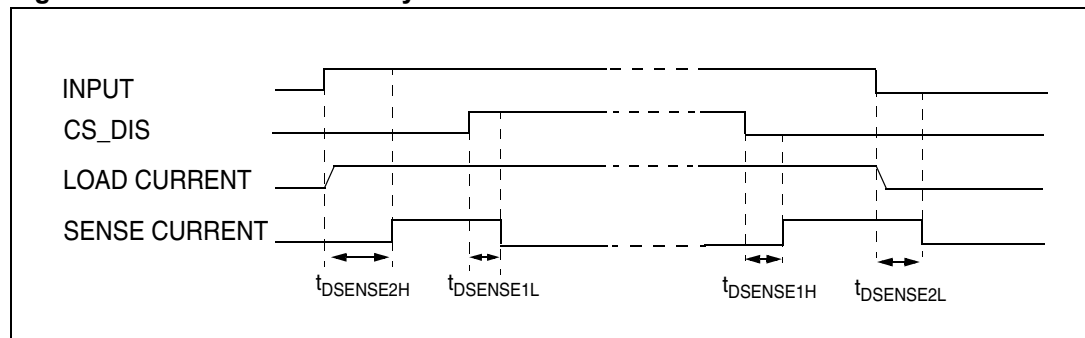
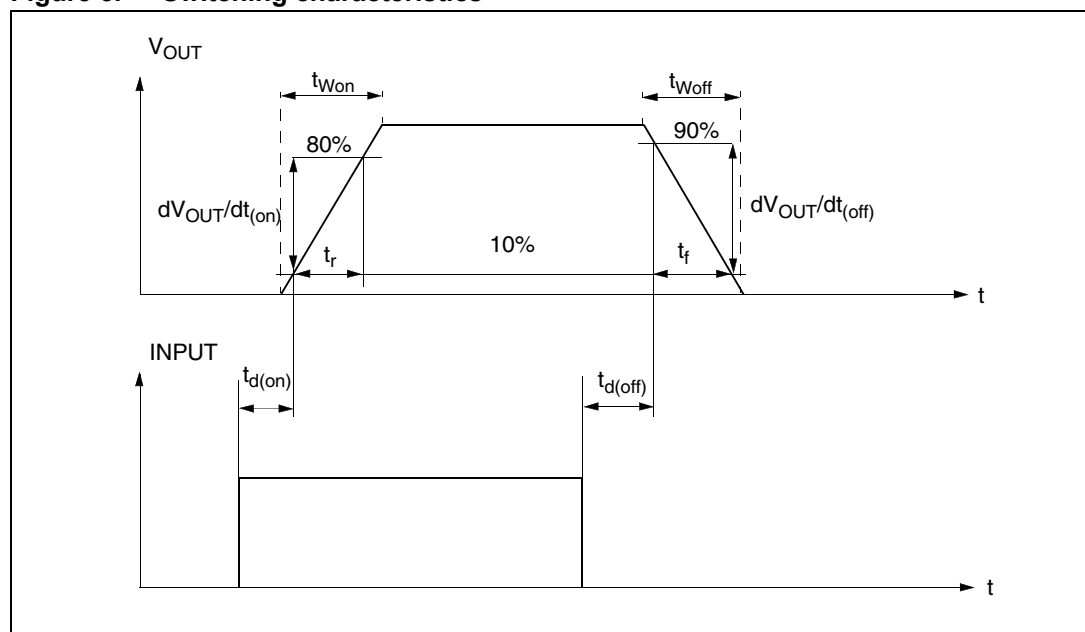
Figure 4. Current sense delay characteristics**Figure 5. Switching characteristics**

Figure 6. Delay response time between rising edge of output current and rising edge of current sense (CS enabled)

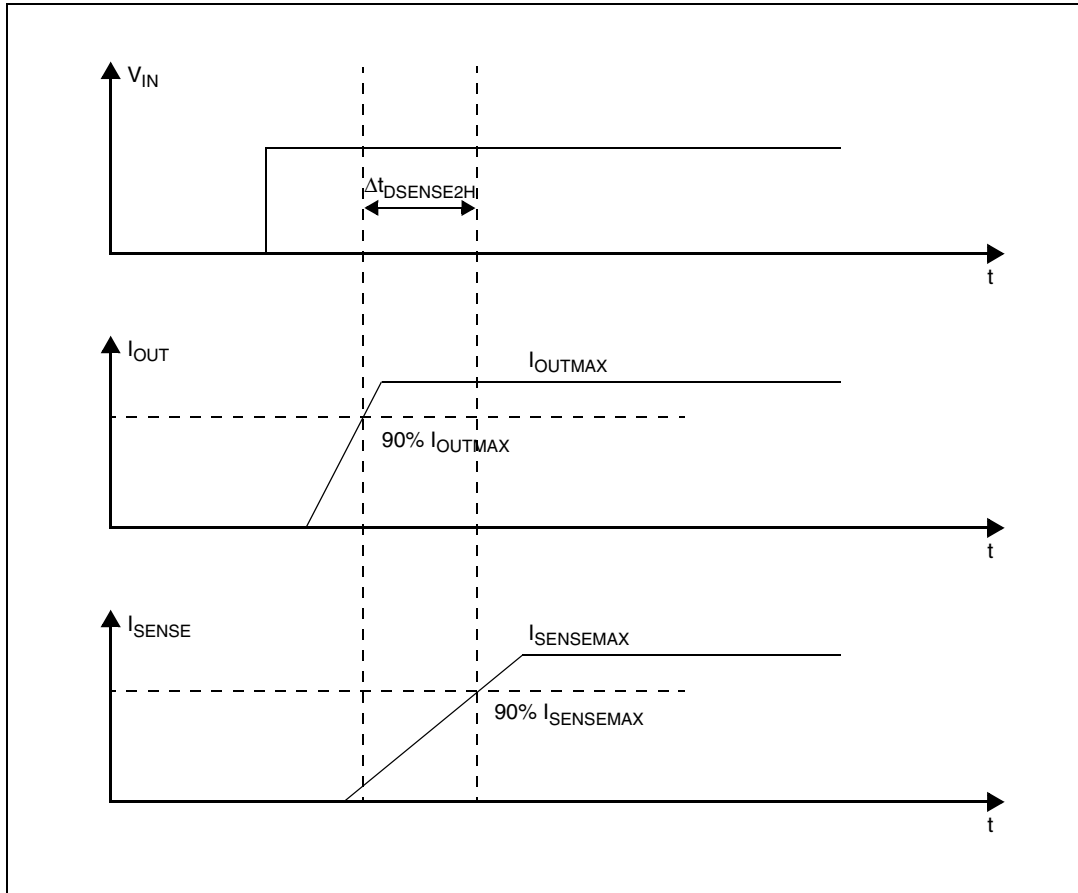
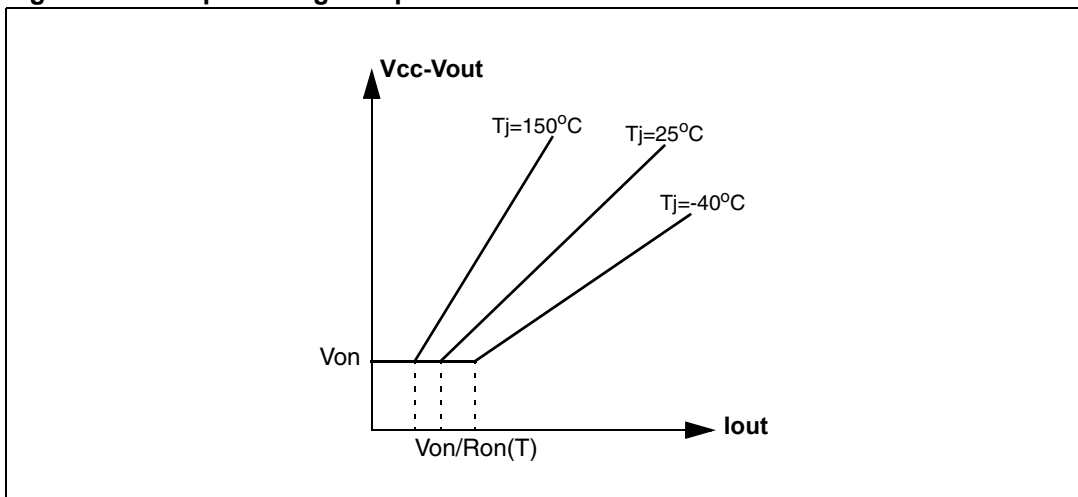


Figure 7. Output voltage drop limitation



www.DataSheet4U.com

Figure 8. I_{OUT}/I_{SENSE} vs I_{OUT}

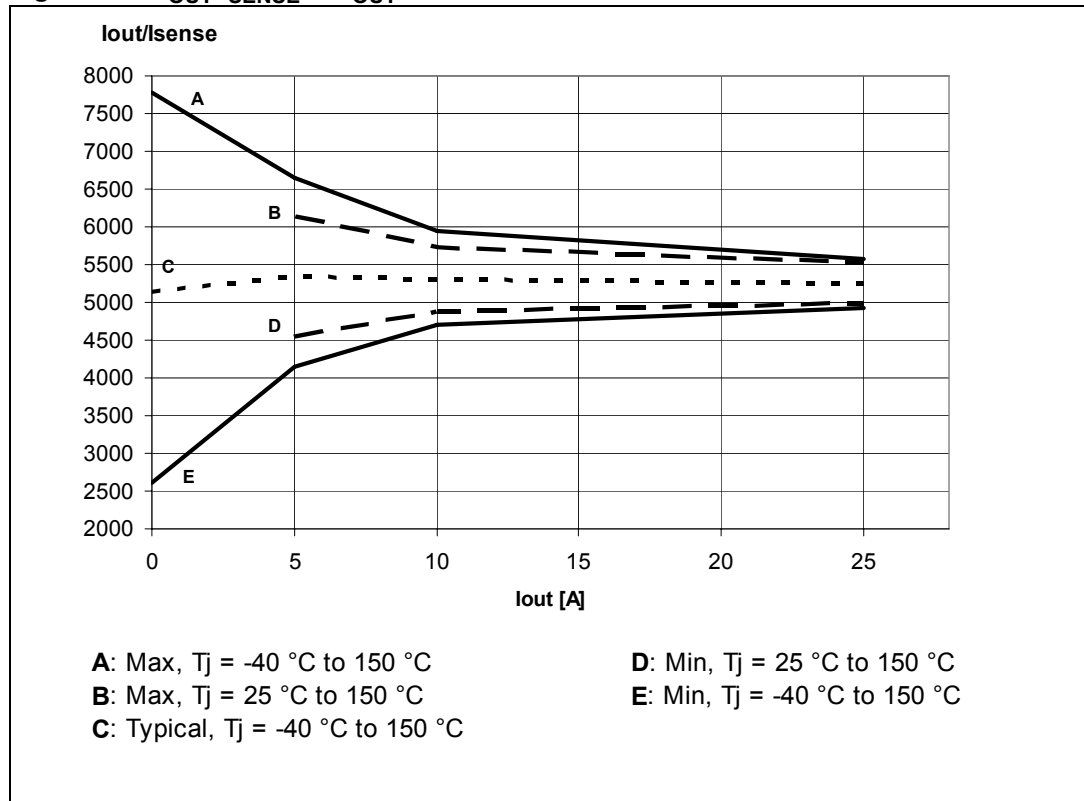
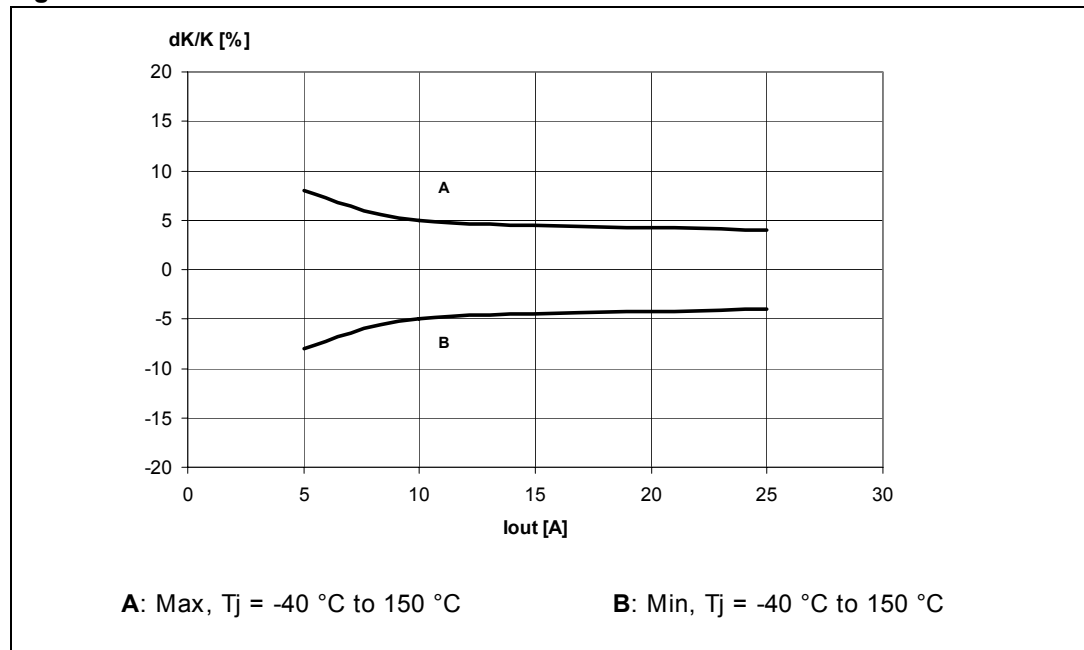


Figure 9. Maximum current sense ratio drift vs load current



Note: Parameter guaranteed by design; it is not tested.

Table 10. Truth table

Conditions	Input	Output	Sense ($V_{CSD}=0V$) ⁽¹⁾
Normal operation	L	L	0
	H	H	Nominal
Overtemperature	L	L	0
	H	L	V_{SENSEH}
Undervoltage	L	L	0
	H	L	0
Overload	H	X	Nominal
	H	(no power limitation) Cycling (power limitation)	V_{SENSEH}
Short circuit to GND (Power limitation)	L	L	0
	H	L	V_{SENSEH}
Negative output voltage clamp	L	L	0

1. If the V_{CSD} is high, the SENSE output is at a high impedance, its potential depends on leakage currents and external circuit.

Table 11. Electrical transient requirements (part 1)

ISO 7637-2: 2004(E) Test pulse	Test levels ⁽¹⁾		Number of pulses or test times	Burst cycle/pulse repetition time		Delays and impedance
	III	IV				
1	-75 V	-100 V	5000 pulses	0.5 s	5 s	2 ms, 10 Ω
2a	+37 V	+50 V	5000 pulses	0.2 s	5 s	50 μs, 2 Ω
3a	-100 V	-150 V	1h	90 ms	100 ms	0.1 μs, 50 Ω
3b	+75 V	+100 V	1h	90 ms	100 ms	0.1 μs, 50 Ω
4	-6 V	-7 V	1 pulse			100 ms, 0.01 Ω
5b ⁽²⁾	+65 V	+87 V	1 pulse			400 ms, 2 Ω

1. The above test levels must be considered referred to $V_{CC} = 13.5$ V except for pulse 5b.
2. Valid in case of external load dump clamp: 40 V maximum referred to ground.

Table 12. Electrical transient requirements (part 2)

ISO 7637-2: 2004(E) Test pulse	Test level results ⁽¹⁾	
	III	IV
1	C	C
2a	C	C
3a	C	C
3b	C	C
4	C	C
5b ⁽²⁾⁽³⁾	C	C

1. The above test levels must be considered referred to $V_{CC} = 13.5$ V except for pulse 5b
2. Valid in case of external load dump clamp: 40 V maximum referred to ground.
3. Suppressed load dump (pulse 5b) is withstood with a minimum load connected as specified in [Table 3: Absolute maximum rating](#).

Table 13. Electrical transient requirements (part 3)

Class	Contents
C	All functions of the device are performed as designed after exposure to disturbance.
E	One or more functions of the device are not performed as designed after exposure to disturbance and cannot be returned to proper operation without replacing the device.

2.4 Waveforms

Figure 10. Normal operation

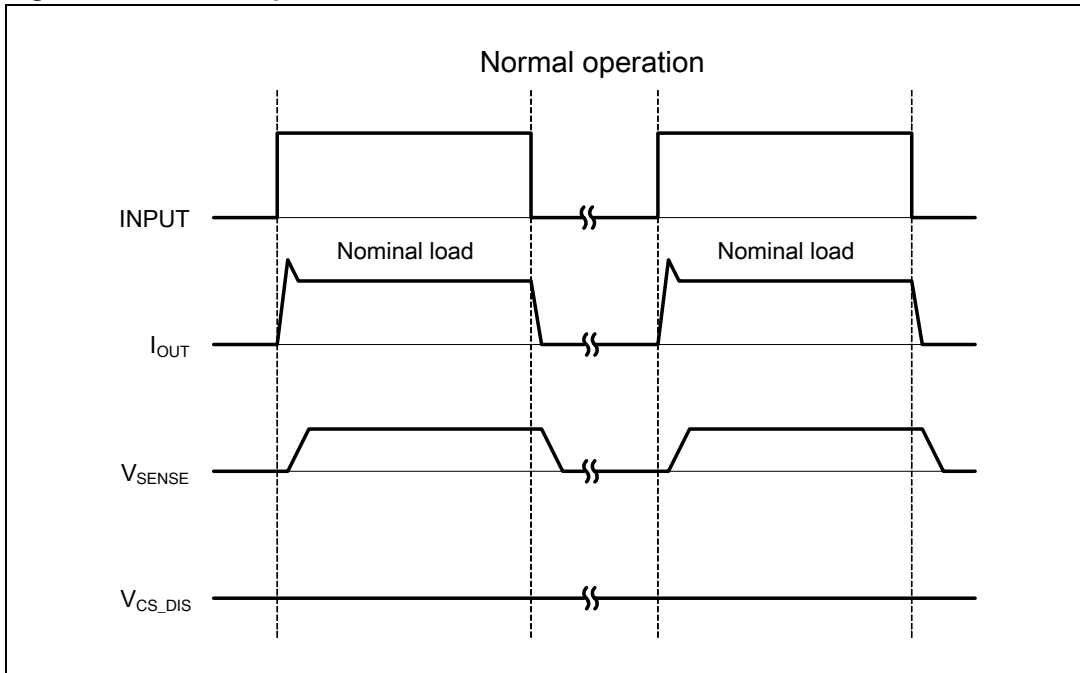
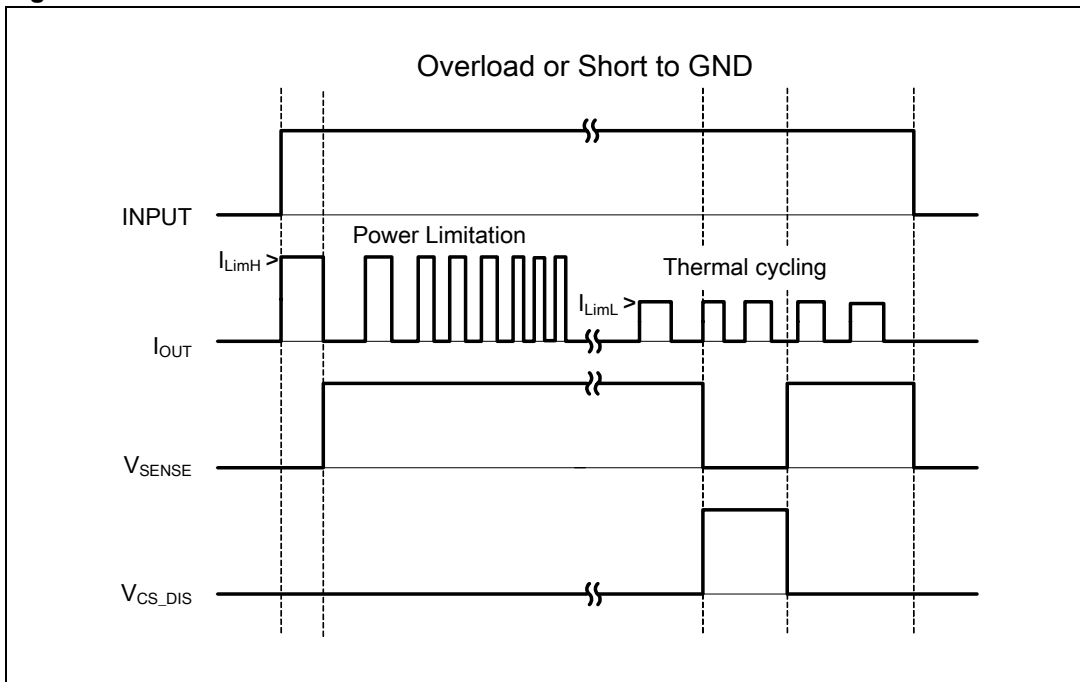


Figure 11. Overload or short to GND



www.DataSheet4U.com

Figure 12. Intermittent overload

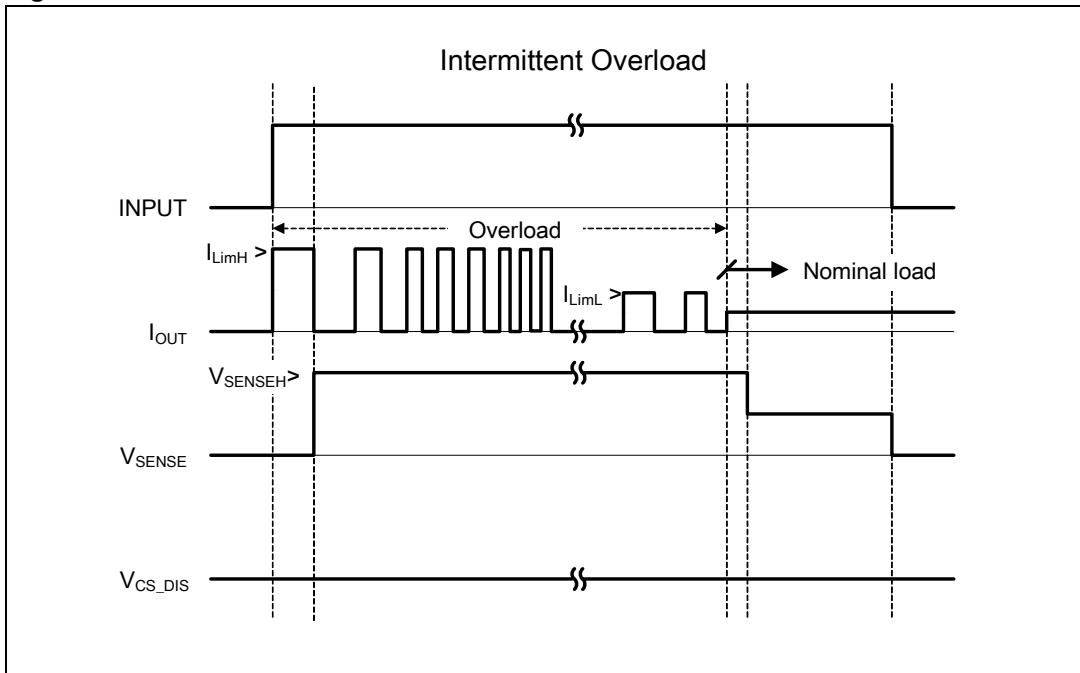
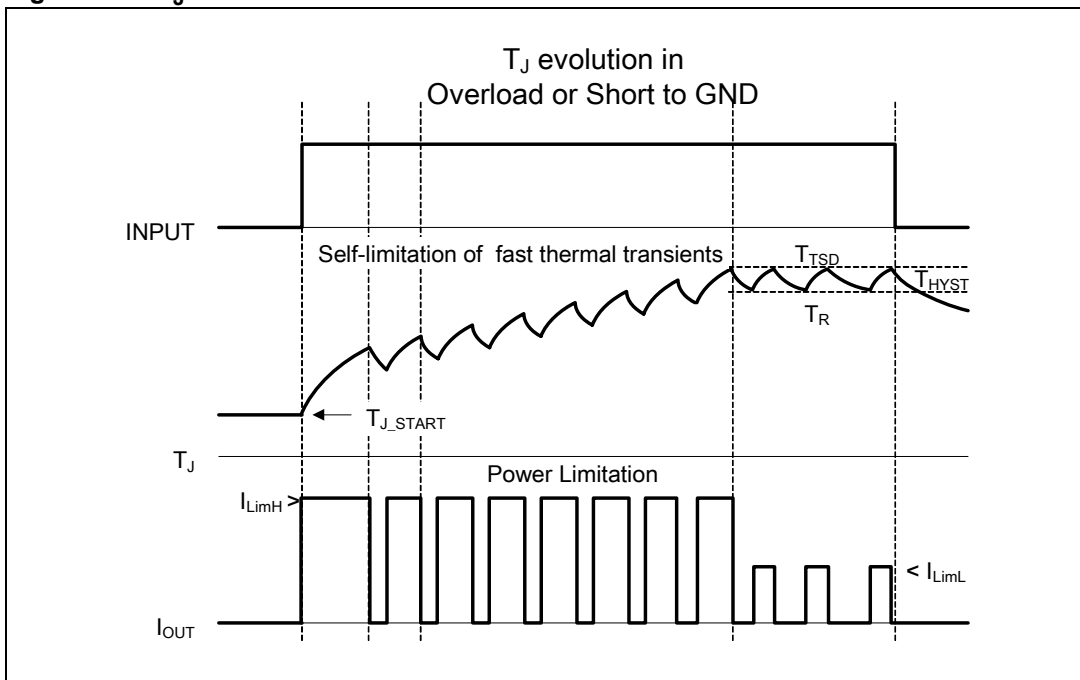


Figure 13. T_J evolution in overload or short to GND



www.DataSheet4U.com

2.5 Electrical characteristics curves

Figure 14. Off-state output current

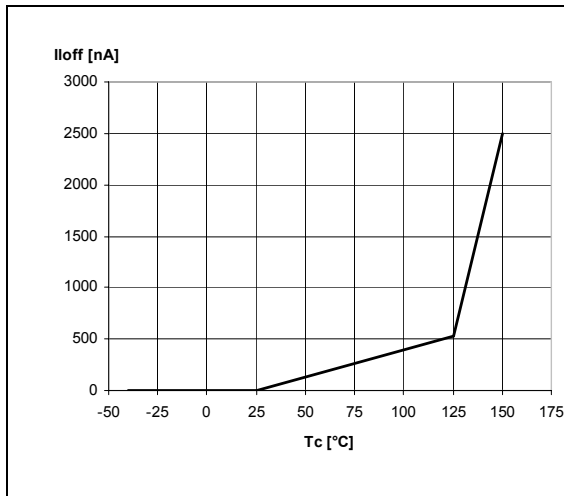


Figure 15. High level input current

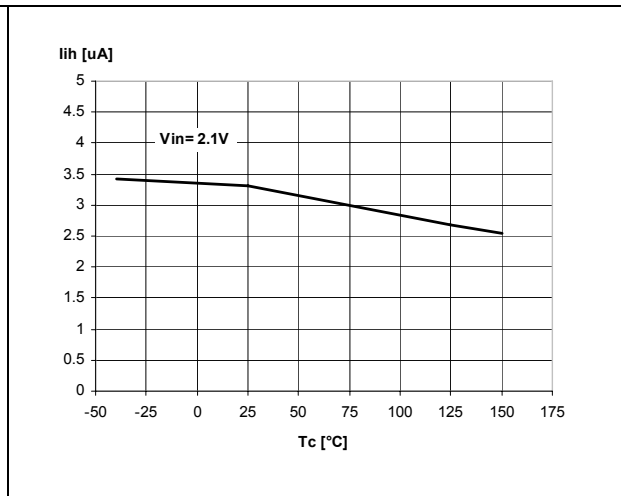


Figure 16. Input clamp voltage

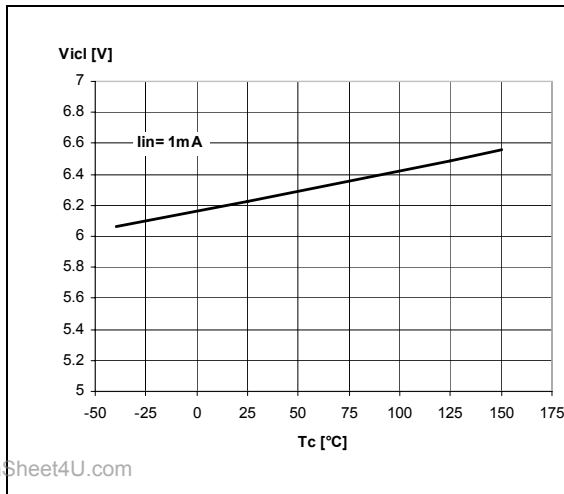


Figure 17. Input high level voltage

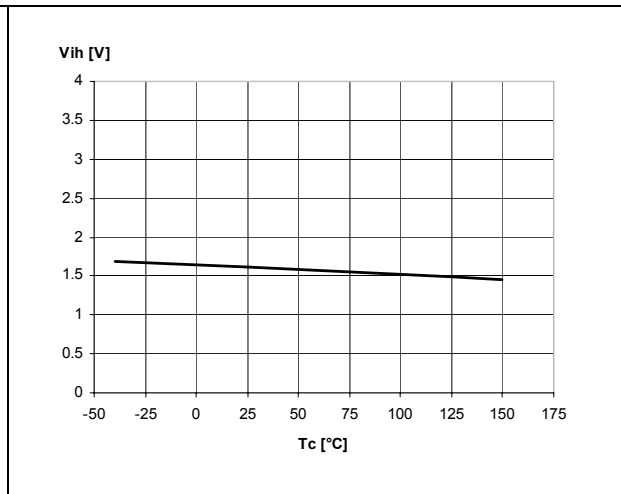


Figure 18. Input low level voltage

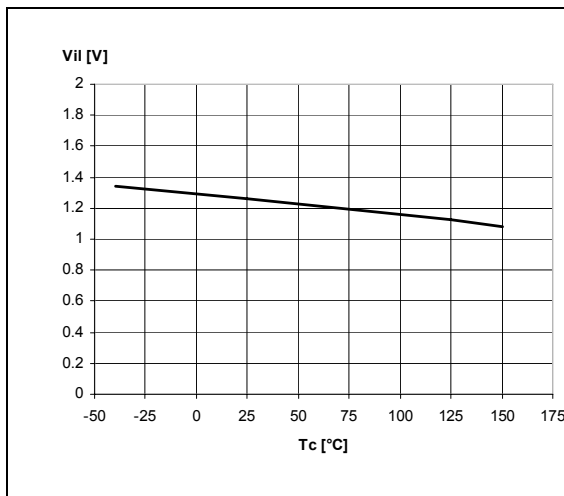
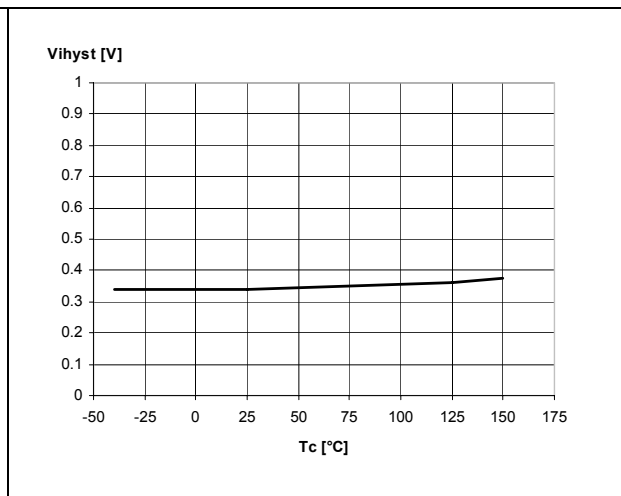


Figure 19. Input hysteresis voltage



www.DataSheet4U.com

Electrical specifications

VND5E012MY-E

Figure 20. On-state resistance vs T_{case}

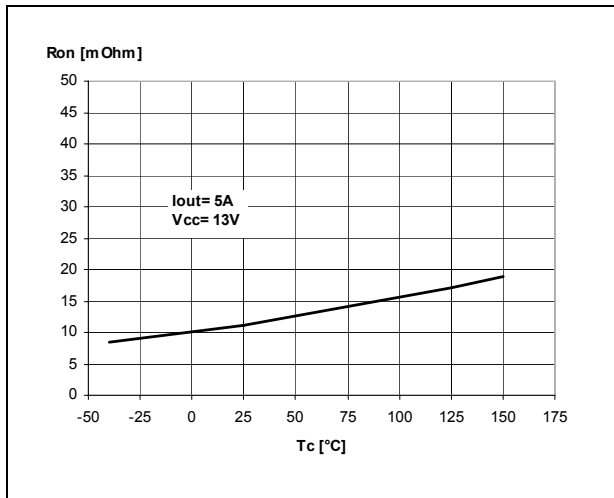


Figure 21. On-state resistance vs V_{CC}

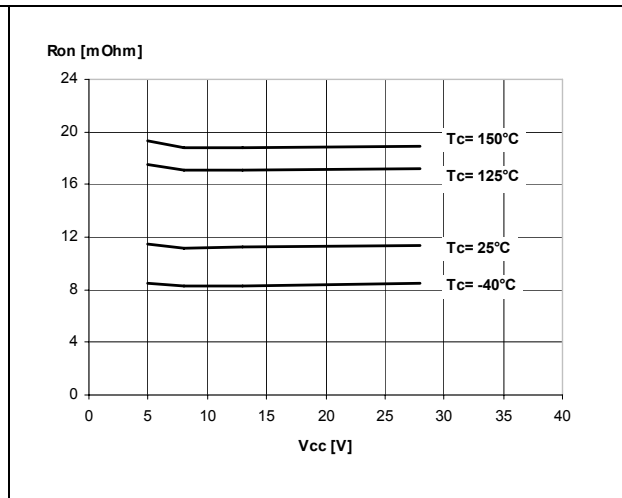


Figure 22. Undervoltage shutdown

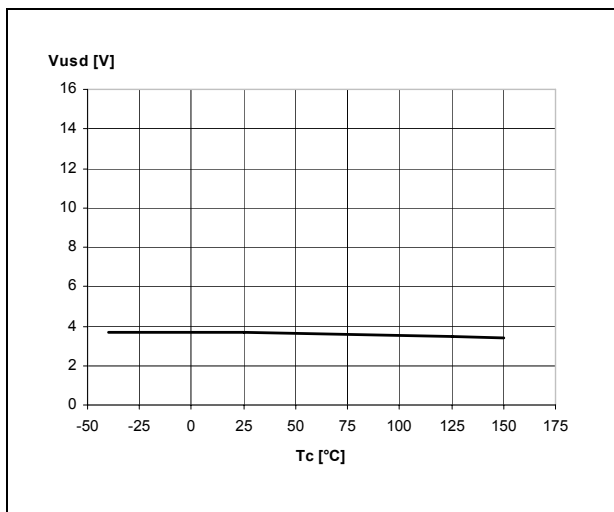


Figure 23. I_{LIMH} vs T_{case}

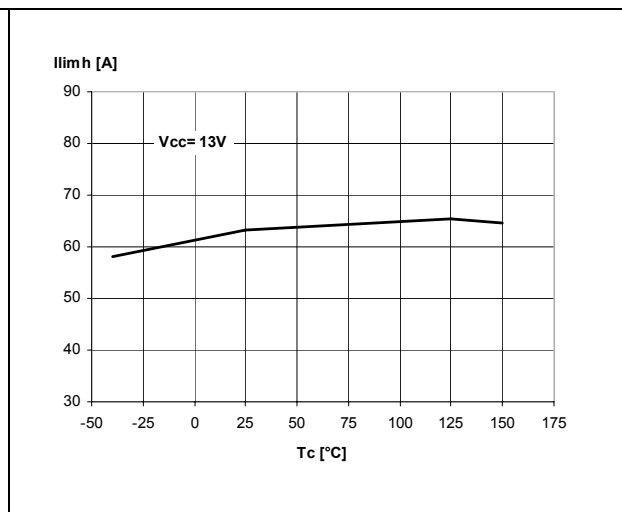


Figure 24. Turn-on voltage slope

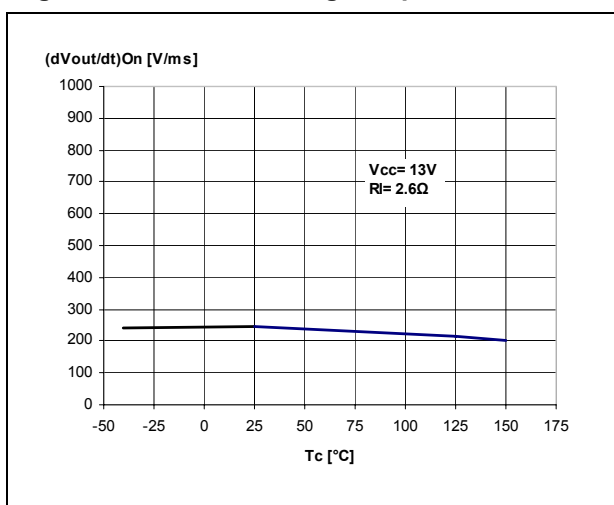


Figure 25. Turn-off voltage slope

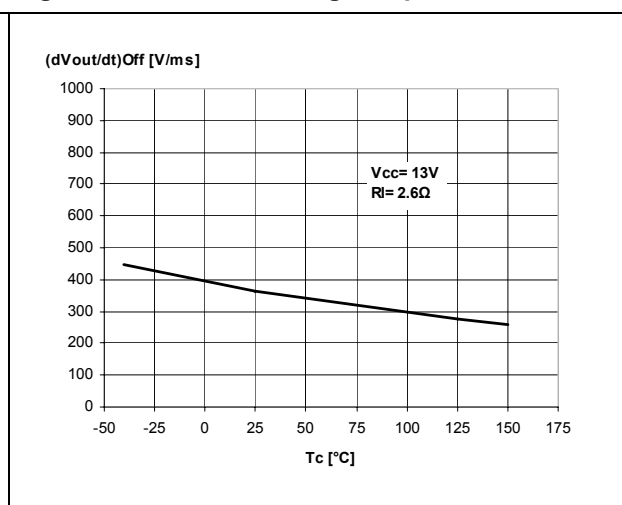


Figure 26. CS_DIS clamp voltage

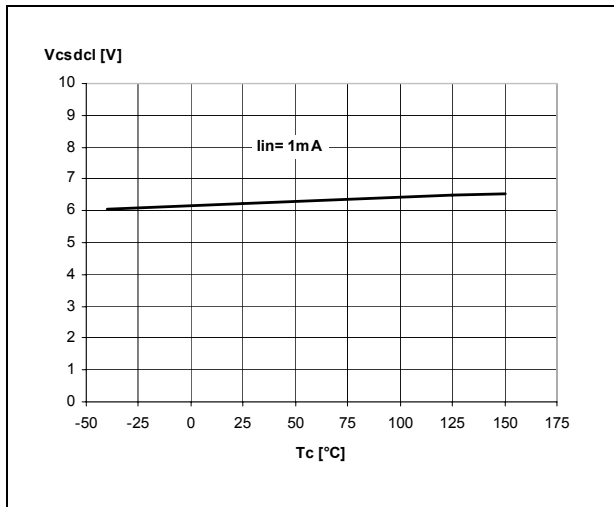


Figure 27. Low level CS_DIS voltage

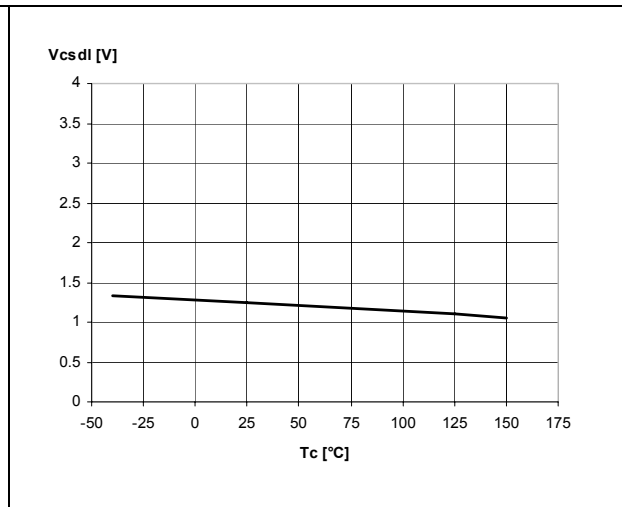
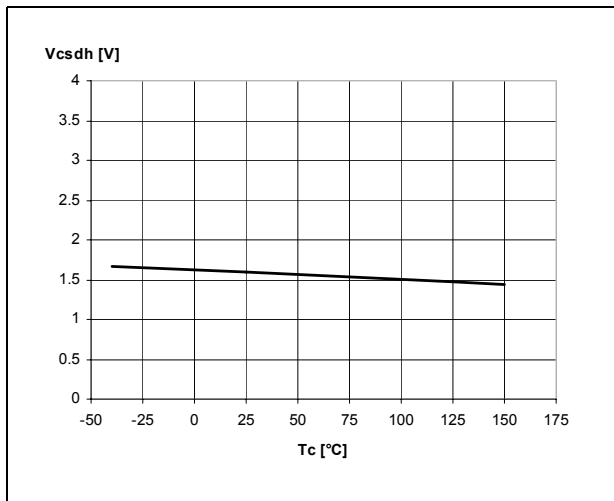
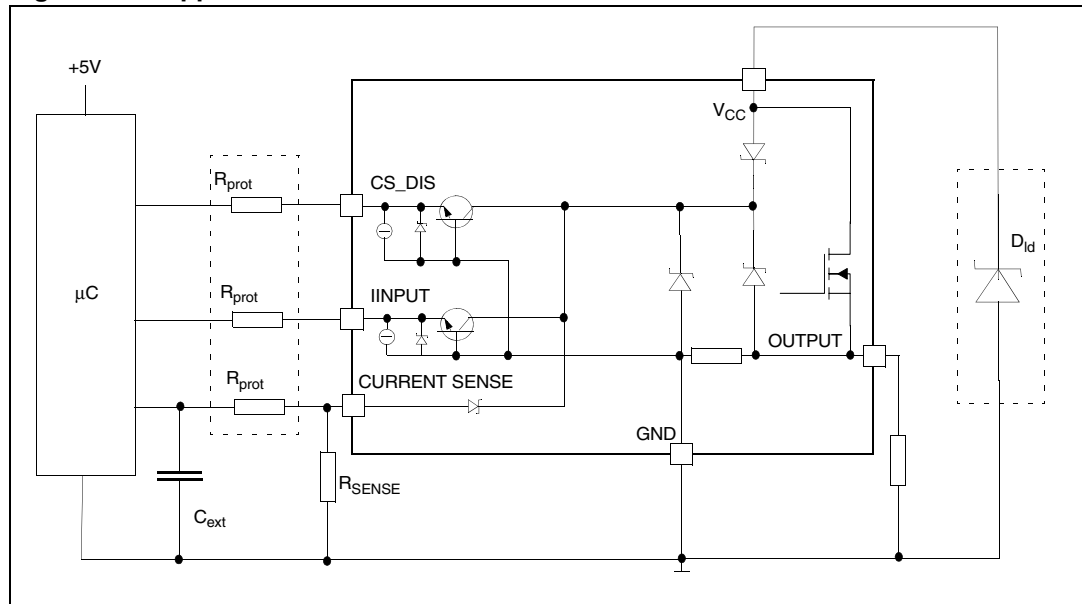


Figure 28. High level CS_DIS voltage



3 Application information

Figure 29. Application schematic



Note: Channel 2 has the same internal circuit as channel 1.

3.1 Load dump protection

D_{id} is necessary (Voltage Transient Suppressor) if the load dump peak voltage exceeds the V_{CCPK} max rating. The same applies if the device is subject to transients on the V_{CC} line that are greater than the ones shown in the ISO 7637-2: 2004(E) table.

3.2 MCU I/Os protection

When negative transients are present on the V_{CC} line, the control pins is pulled negative to approximately -1.5 V. ST suggests to insert a resistor (R_{prot}) in line to prevent the microcontroller I/Os pins to latch-up.

The value of these resistors is a compromise between the leakage current of microcontroller and the current required by the HSD I/Os (input levels compatibility) with the latch-up limit of microcontroller I/Os.

Equation 1

$$-V_{CCpeak} / I_{latchup} \leq R_{prot} \leq (V_{OH\mu C} - V_{IH}) / I_{IHmax}$$

Calculation example:

For $V_{CCpeak} = -1.5$ V; $I_{latchup} \geq 20$ mA; $V_{OH\mu C} \geq 4.5$ V

$$75 \Omega \leq R_{\text{prot}} \leq 240 \text{ k}\Omega$$

Recommended values: $R_{\text{prot}} = 10 \text{ k}\Omega$, $C_{\text{EXT}} = 10 \text{ nF}$.

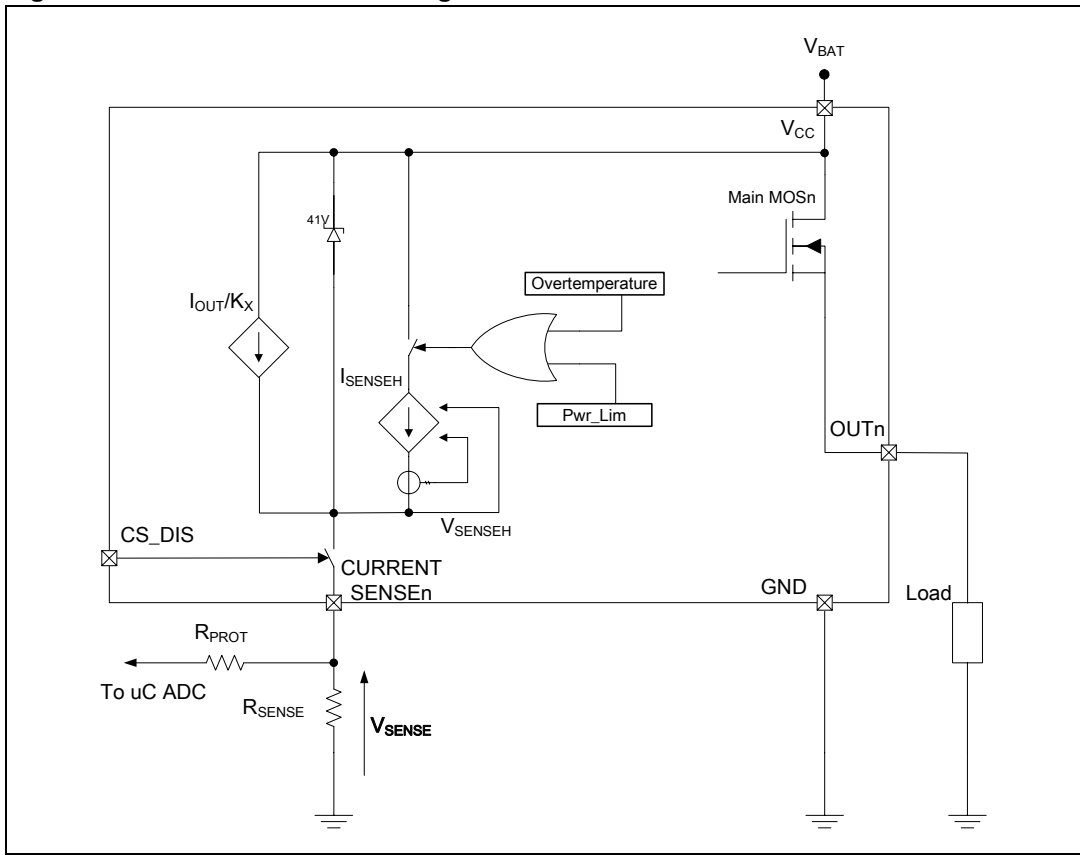
3.3 Current sense and diagnostic

The current sense pin performs a double function (see [Figure 30: Current sense and diagnostic](#)):

- **Current mirror of the load current in normal operation**, delivering a current proportional to the load one according to a known ratio K_x .
The current I_{SENSE} can be easily converted to a voltage V_{SENSE} by means of an external resistor R_{SENSE} . Linearity between I_{OUT} and V_{SENSE} is ensured up to 5V minimum (see parameter V_{SENSE} in [Table 9: Current sense \(8V < V_{CC} < 18V\)](#)). The current sense accuracy depends on the output current (refer to current sense electrical characteristics [Table 9: Current sense \(8V < V_{CC} < 18V\)](#)).
- **Diagnostic flag in fault conditions**, delivering a fixed voltage V_{SENSEH} up to a maximum current I_{SENSEH} in case of the following fault conditions (refer to [Truth table](#)):
 - Power limitation activation
 - Overtemperature

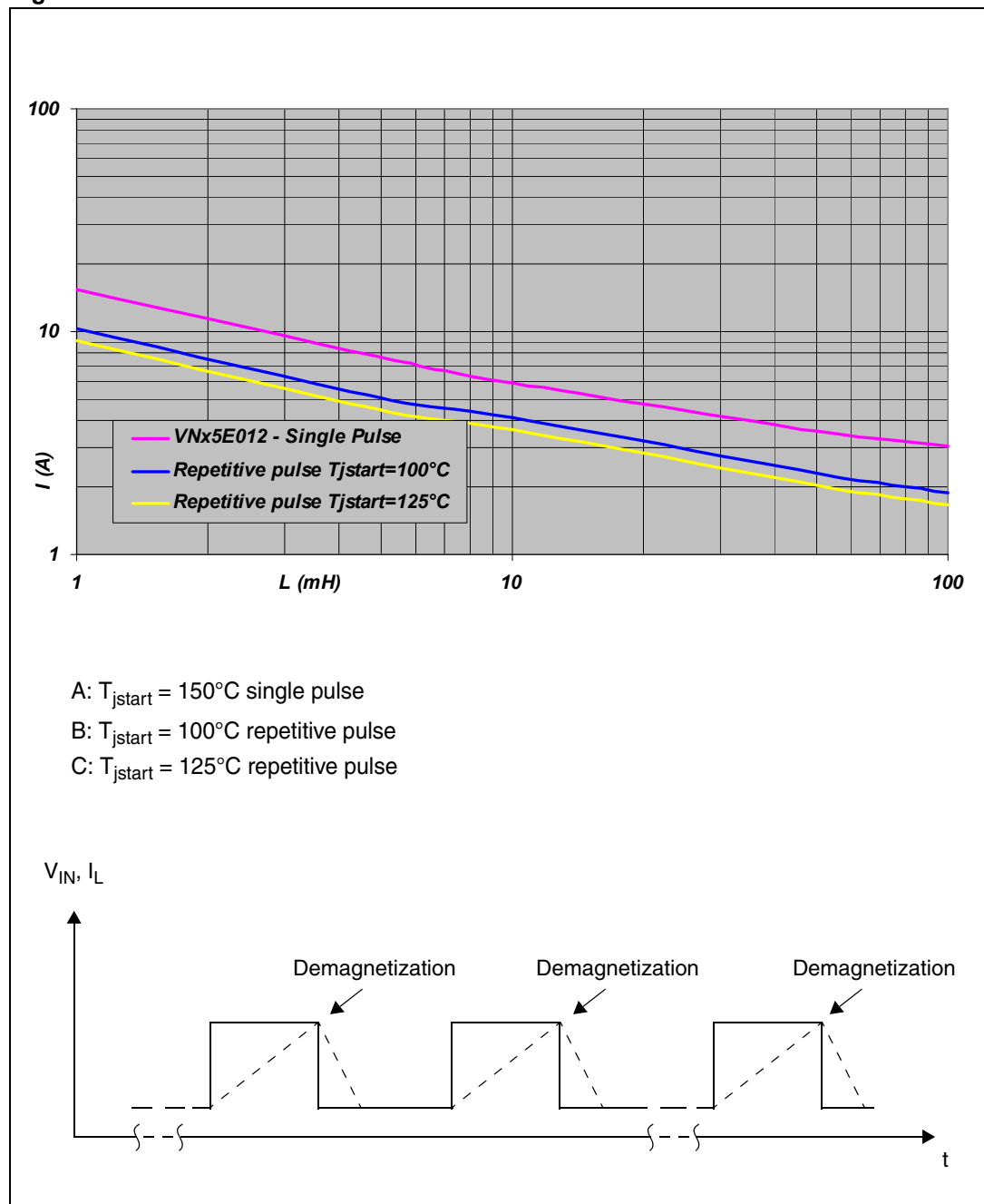
A logic level high on CS_DIS pin sets at the same time all the current sense pins of the device in a high impedance state, thus disabling the current monitoring and diagnostic detection. This feature allows multiplexing of the microcontroller analog inputs by sharing of sense resistance and ADC line among different devices.

Figure 30. Current sense and diagnostic



3.4 Maximum demagnetization energy ($V_{CC} = 13.5V$)

Figure 31. Maximum turn-off current versus inductance



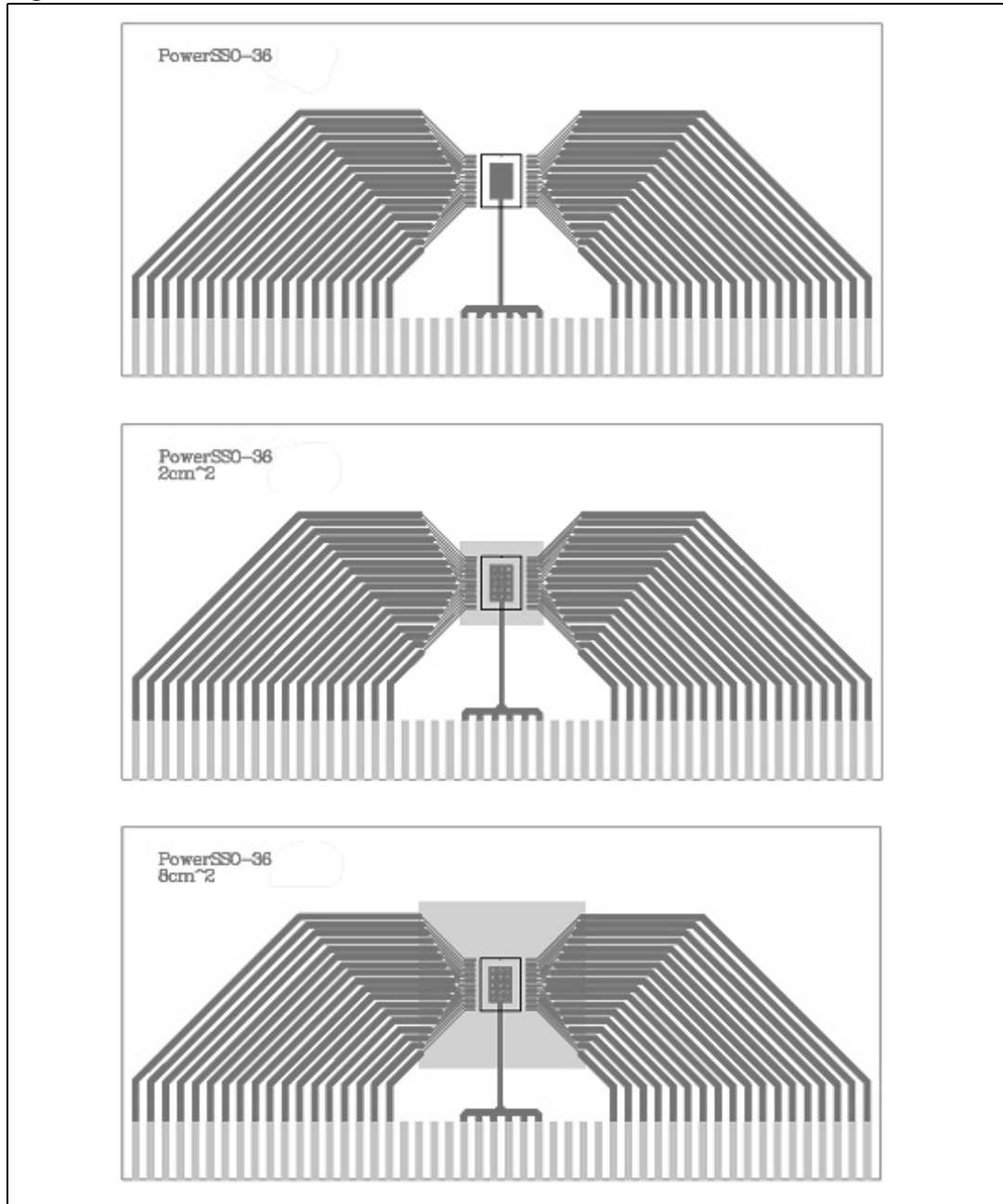
Note: Values are generated with $R_L = 0 \Omega$.

In case of repetitive pulses, T_{jstart} (at beginning of each demagnetization) of every pulse must not exceed the temperature specified above for curves A and B.

4 Package and PCB thermal data

4.1 PowerSSO-36 thermal data

Figure 32. PowerSSO-36 PC board



www.DataSheet4U.com

Note: Layout condition of R_{th} and Z_{th} measurements (PCB: Double layer, Thermal Vias, FR4 area= 129mm x 60mm, PCB thickness=1.6mm, Cu thickness=70 μ m (front and back side), Copper areas: from minimum pad lay-out to 8cm²).

Figure 33. $R_{thj-amb}$ vs PCB copper area in open box free air condition (one channel ON)

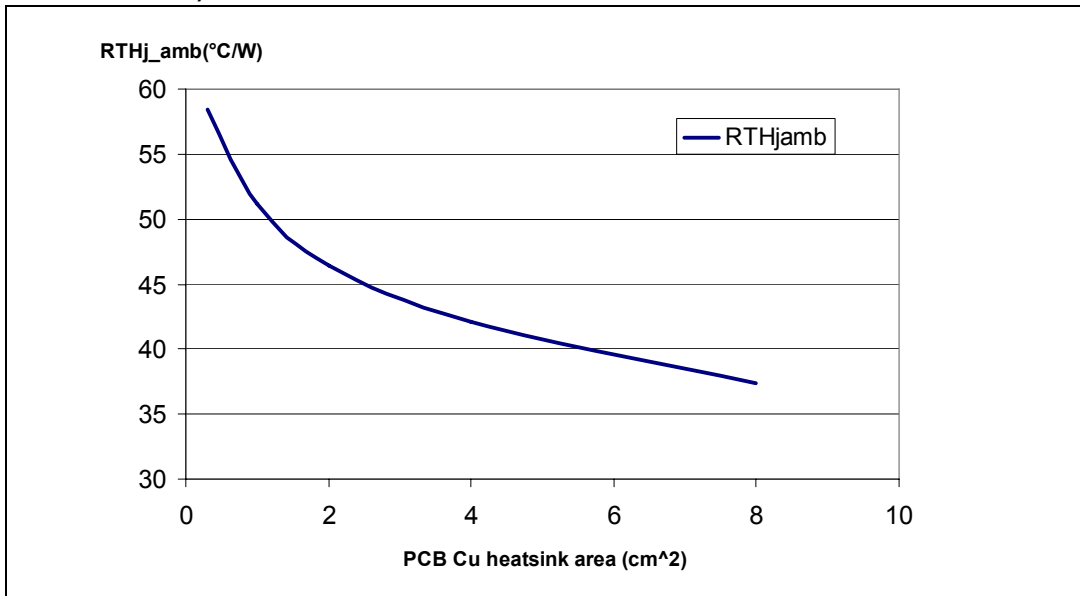
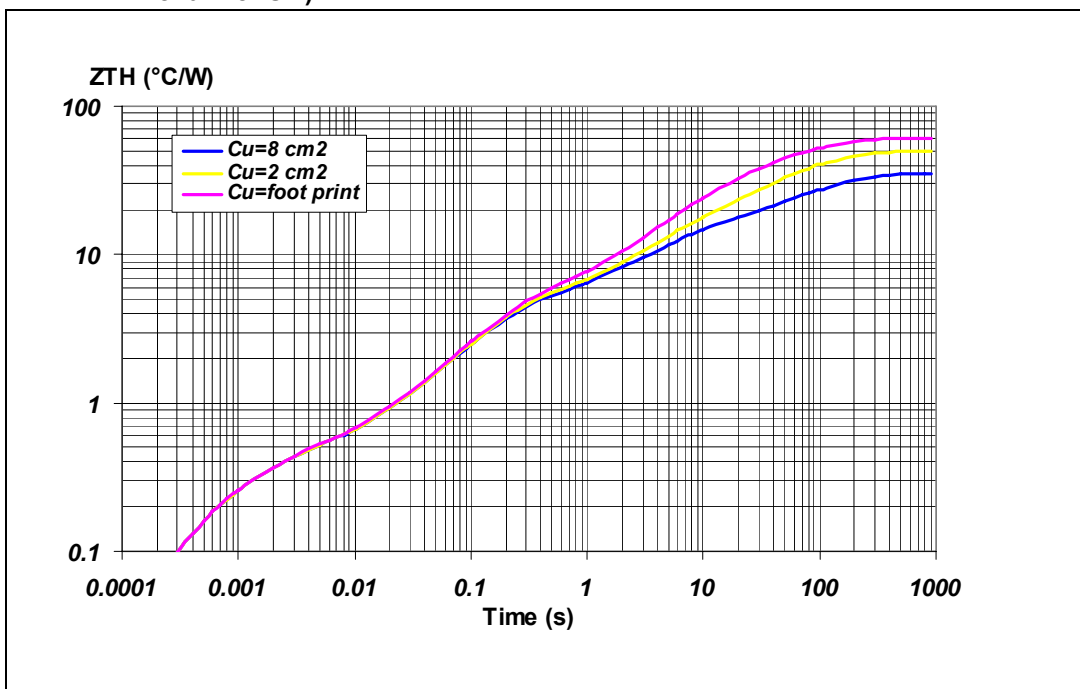
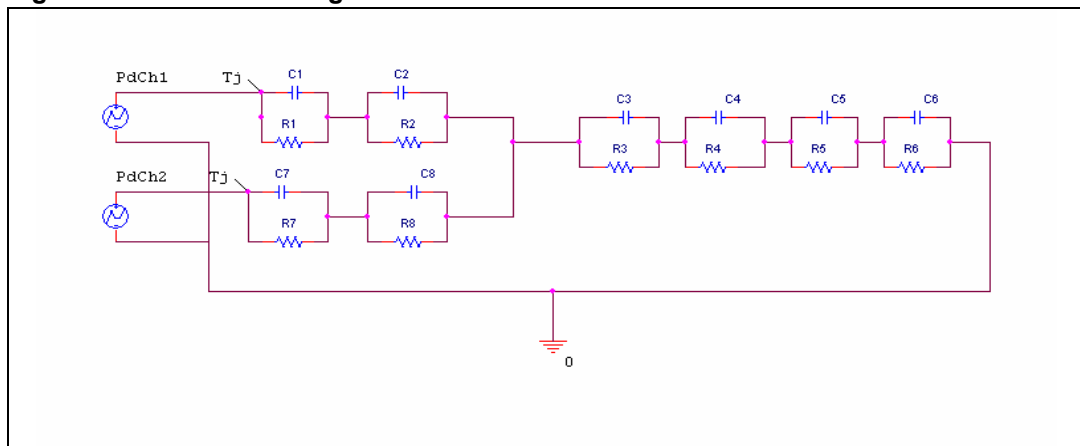


Figure 34. PowerSSO-36 thermal impedance junction ambient single pulse (one channel ON)



www.DataSheet4U.com

Figure 35. Thermal fitting model of a double channel HSD in PowerSSO-36⁽¹⁾

1. The fitting model is a simplified thermal tool and is valid for transient evolutions where the embedded protections (power limitation or thermal cycling during thermal shutdown) are not triggered.

Equation 2: pulse calculation formula

$$Z_{TH\delta} = R_{TH} \cdot \delta + Z_{THtp}(1 - \delta)$$

$$\text{where } \delta = t_p/T$$

Table 14. Thermal parameter

Area/island (cm ²)	Footprint	2	8
R1 (°C/W)	0.1		
R2 (°C/W)	0.3		
R3 (°C/W)	5		
R4 (°C/W)	8		
R5 (°C/W)	18	10	10
R6 (°C/W)	27	23	14
R7 (°C/W)	0.1		
R8 (°C/W)	0.3		
C1 (W.s/°C)	0.0025		
C2 (W.s/°C)	0.005		
C3 (W.s/°C)	0.04		
C4 (W.s/°C)	0.5		
C5 (W.s/°C)	1	2	2
C6 (W.s/°C)	3	6	9
C7 (W.s/°C)	0.0025		
C8 (W.s/°C)	0.005		

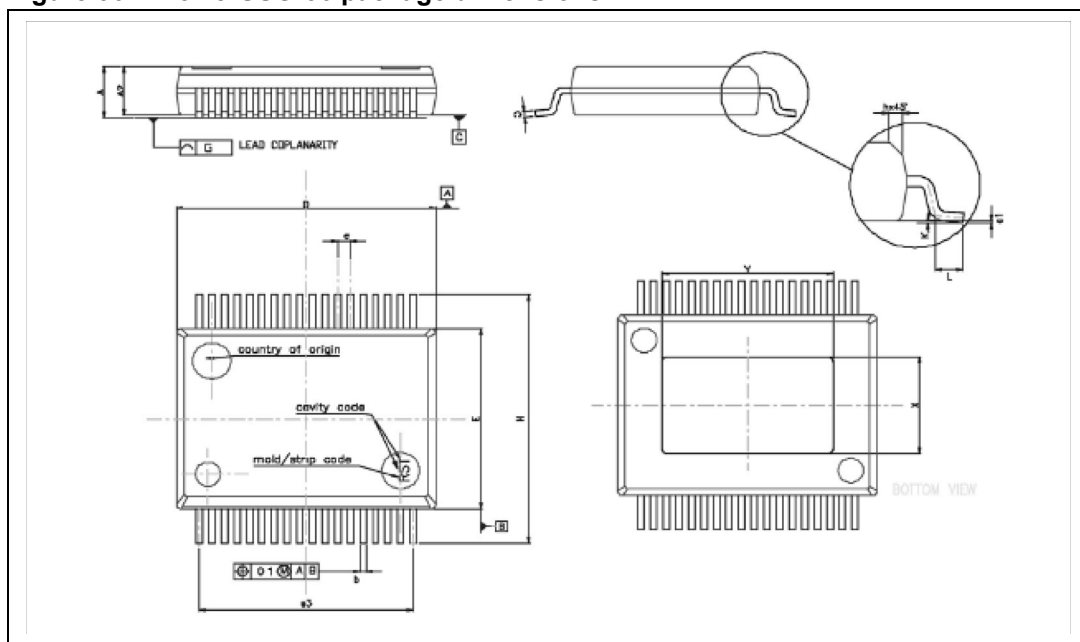
5 Package information

5.1 ECOPACK[®] package

In order to meet environmental requirements, ST offers these devices in different grades of ECOPACK[®] packages, depending on their level of environmental compliance. ECOPACK[®] specifications, grade definitions and product status are available at: www.st.com. ECOPACK[®] is an ST trademark.

5.2 PowerSSO-36 mechanical data

Figure 36. PowerSSO-36 package dimensions



www.DataSheet4U.com

Table 15. PowerSSO-36 mechanical data

Symbol	Millimeters		
	Min.	Typ.	Max.
A	2.15	-	2.47
A2	2.15	-	2.40
a1	0	-	0.075
b	0.18	-	0.36
c	0.23	-	0.32
D	10.10	-	10.50
E	7.4	-	7.6
e	-	0.5	-
e3	-	8.5	-
G	-	-	0.1
G1	-	-	0.06
H	10.1	-	10.5
h	-	-	0.4
L	0.55	-	0.85
N	-	-	10 deg
X	4.1	-	4.7
Y	6.5	-	7.1

5.3 Packing information

Figure 37. PowerSSO-36 tube shipment (no suffix)

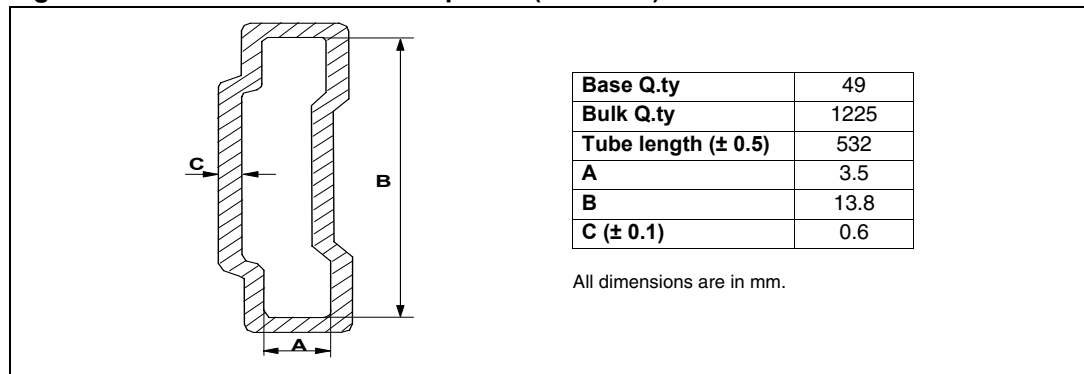
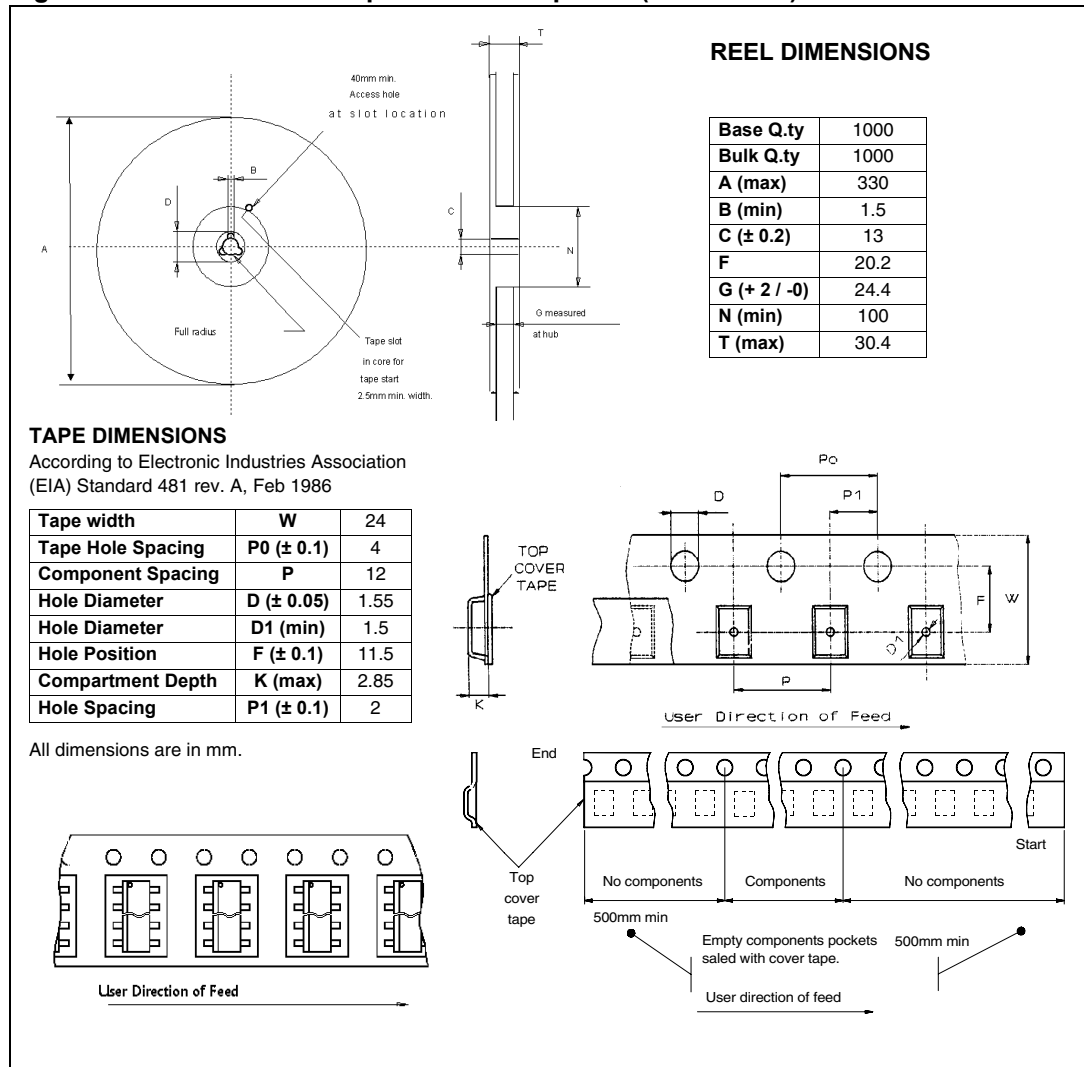


Figure 38. PowerSSO-36 tape and reel shipment (suffix "TR")



www.DataSheet4U.com

6 Order codes

Table 16. Device summary

Package	Order codes	
	Tube	Tape and reel
PowerSSO-36	VND5E012MY-E	VND5E012MYTR-E

7 Revision history

Table 17. Document revision history

Date	Revision	Changes
21-Oct-2009	1	Initial release.
04-Dec-2009	2	Updated Section 4.1: PowerSSO-36 thermal data

Please Read Carefully:

Information in this document is provided solely in connection with ST products. STMicroelectronics NV and its subsidiaries ("ST") reserve the right to make changes, corrections, modifications or improvements, to this document, and the products and services described herein at any time, without notice.

All ST products are sold pursuant to ST's terms and conditions of sale.

Purchasers are solely responsible for the choice, selection and use of the ST products and services described herein, and ST assumes no liability whatsoever relating to the choice, selection or use of the ST products and services described herein.

No license, express or implied, by estoppel or otherwise, to any intellectual property rights is granted under this document. If any part of this document refers to any third party products or services it shall not be deemed a license grant by ST for the use of such third party products or services, or any intellectual property contained therein or considered as a warranty covering the use in any manner whatsoever of such third party products or services or any intellectual property contained therein.

UNLESS OTHERWISE SET FORTH IN ST'S TERMS AND CONDITIONS OF SALE ST DISCLAIMS ANY EXPRESS OR IMPLIED WARRANTY WITH RESPECT TO THE USE AND/OR SALE OF ST PRODUCTS INCLUDING WITHOUT LIMITATION IMPLIED WARRANTIES OF MERCHANTABILITY, FITNESS FOR A PARTICULAR PURPOSE (AND THEIR EQUIVALENTS UNDER THE LAWS OF ANY JURISDICTION), OR INFRINGEMENT OF ANY PATENT, COPYRIGHT OR OTHER INTELLECTUAL PROPERTY RIGHT.

UNLESS EXPRESSLY APPROVED IN WRITING BY AN AUTHORIZED ST REPRESENTATIVE, ST PRODUCTS ARE NOT RECOMMENDED, AUTHORIZED OR WARRANTED FOR USE IN MILITARY, AIR CRAFT, SPACE, LIFE SAVING, OR LIFE SUSTAINING APPLICATIONS, NOR IN PRODUCTS OR SYSTEMS WHERE FAILURE OR MALFUNCTION MAY RESULT IN PERSONAL INJURY, DEATH, OR SEVERE PROPERTY OR ENVIRONMENTAL DAMAGE. ST PRODUCTS WHICH ARE NOT SPECIFIED AS "AUTOMOTIVE GRADE" MAY ONLY BE USED IN AUTOMOTIVE APPLICATIONS AT USER'S OWN RISK.

www.DataSheet4U.com

Resale of ST products with provisions different from the statements and/or technical features set forth in this document shall immediately void any warranty granted by ST for the ST product or service described herein and shall not create or extend in any manner whatsoever, any liability of ST.

ST and the ST logo are trademarks or registered trademarks of ST in various countries.

Information in this document supersedes and replaces all information previously supplied.

The ST logo is a registered trademark of STMicroelectronics. All other names are the property of their respective owners.

© 2009 STMicroelectronics - All rights reserved

STMicroelectronics group of companies

Australia - Belgium - Brazil - Canada - China - Czech Republic - Finland - France - Germany - Hong Kong - India - Israel - Italy - Japan - Malaysia - Malta - Morocco - Philippines - Singapore - Spain - Sweden - Switzerland - United Kingdom - United States of America

www.st.com