



# VNB14N04 - VNK14N04FM VNV14N04

"OMNIFET"  
fully autoprotected Power MOSFET

## Features

Type	V <sub>clamp</sub>	R <sub>DS(on)</sub>	I <sub>lim</sub>
VNB14N04	42 V	0.07 Ω	14 A
VNK14N04FM	42 V	0.07 Ω	14 A
VNV14N04	42 V	0.07 Ω	14 A

- Linear current limitation
- Thermal shutdown
- Short circuit protection
- Integrated clamp
- Low current drawn from input pin
- Diagnostic feedback through input pin
- ESD protection
- Direct access to the gate of the power MOSFET (analog driving)
- Compatible with standard power MOSFET



## Description

The VNB14N04, VNK14N04FM and VNV14N04 are monolithic devices made using STMicroelectronics VIPower M0 Technology, intended for replacement of standard power MOSFETS in DC to 50 kHz applications. Built-in thermal shutdown, linear current limitation and overvoltage clamp protect the chip in harsh environment.

Fault feedback can be detected by monitoring the voltage at the input pin.

**Table 1. Device summary**

Part number	Order code
VNB14N04	VNB14N04, VNB14N04-E, VNB14N0413TR, VNB14N04TR-E
VNK14N04FM	VNK14N04FM
VNV14N04	VNV14N04, VNV14N04-E

# Contents

<b>1</b>	<b>Block diagram</b> .....	<b>3</b>
<b>2</b>	<b>Electrical specification</b> .....	<b>4</b>
2.1	Absolute maximum rating .....	4
2.2	Thermal data .....	4
2.3	Electrical characteristics .....	4
<b>3</b>	<b>Protection features</b> .....	<b>7</b>
<b>4</b>	<b>Package information</b> .....	<b>13</b>
<b>5</b>	<b>Revision history</b> .....	<b>16</b>

Obsolete Product(s) - Obsolete Product(s)

# 1 Block diagram

Figure 1. Block diagram

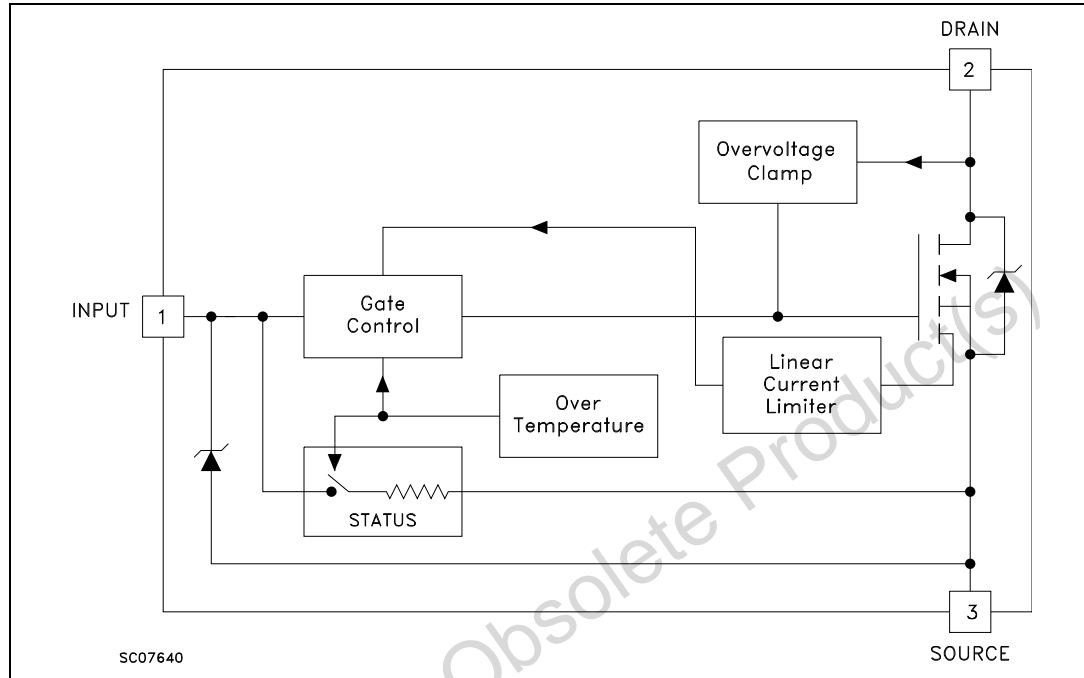

1. PowerSO-10 pin configuration : INPUT = 6,7,8,9,10; SOURCE = 1,2,4,5; DRAIN = TAB

## 2 Electrical specification

### 2.1 Absolute maximum rating

Table 2. Absolute maximum rating

Symbol	Parameter	Value		Unit
		PowerSO-10 D2PAK	SOT-82FM	
V <sub>DS</sub>	Drain-source voltage (V <sub>in</sub> = 0)	Internally clamped		V
V <sub>in</sub>	Input voltage	18		V
I <sub>D</sub>	Drain current	Internally limited		A
I <sub>R</sub>	Reverse DC output current	-14		A
V <sub>esd</sub>	Electrostatic discharge (C = 100 pF, R=1.5 KΩ)	2000		V
P <sub>tot</sub>	Total dissipation at T <sub>c</sub> = 25 °C	50	9.5	W
T <sub>j</sub>	Operating junction temperature	Internally limited		°C
T <sub>c</sub>	Case operating temperature	Internally limited		°C
T <sub>stg</sub>	Storage temperature	-55 to 150		°C

### 2.2 Thermal data

Table 3. Thermal data

Symbol	Parameter	PowerSO-10	SOT82-FM	D2PAK	Unit
R <sub>thj-case</sub>	Thermal resistance junction-case max	2.5	13	2.5	°C/W
R <sub>thj-amb</sub>	Thermal resistance junction-ambient max	50	100	62.5	°C/W

### 2.3 Electrical characteristics

T<sub>case</sub> = 25 °C unless otherwise specified.

Table 4. Electrical characteristics

Symbol	Parameter	Test conditions	Min.	Typ.	Max.	Unit
<b>Off</b>						
V <sub>CLAMP</sub>	Drain-source clamp voltage	I <sub>D</sub> = 200 mA V <sub>in</sub> = 0	36	42	48	V
V <sub>CLTH</sub>	Drain-source clamp threshold voltage	I <sub>D</sub> = 2 mA V <sub>in</sub> = 0	35			V
V <sub>INCL</sub>	Input-source reverse clamp voltage	I <sub>in</sub> = -1 mA	-1		-0.3	V

Table 4. Electrical characteristics (continued)

Symbol	Parameter	Test conditions	Min.	Typ.	Max.	Unit
$I_{DSS}$	Zero input voltage drain current ( $V_{in} = 0$ )	$V_{DS} = 13\text{ V } V_{in} = 0$			50	$\mu\text{A}$
		$V_{DS} = 25\text{ V } V_{in} = 0$			200	$\mu\text{A}$
$I_{ISS}$	Supply current from input pin	$V_{DS} = 0\text{ V } V_{in} = 10\text{ V}$		250	500	$\mu\text{A}$
<b>On<sup>(1)</sup></b>						
$V_{IN(th)}$	Input threshold voltage	$V_{DS} = V_{in} I_D + I_{in} = 1\text{ mA}$	0.8		3	V
$R_{DS(on)}$	Static drain-source on resistance	$V_{in} = 10\text{ V } I_D = 7\text{ A}$			0.7	$\Omega$
		$V_{in} = 5\text{ V } I_D = 7\text{ A}$			0.1	$\Omega$
<b>Dynamic</b>						
$g_{fs}^{(1)}$	Forward transconductance	$V_{DS} = 13\text{ V } I_D = 7\text{ A}$	8	10		S
$C_{OSS}$	Output capacitance	$V_{DS} = 13\text{ V } f = 1\text{ MHz } V_{in} = 0$		400	500	pF
<b>Switching<sup>(2)</sup></b>						
$t_{d(on)}$ $t_r$ $t_{d(off)}$ $t_f$	Turn-on delay time	$V_{DD} = 15\text{ V } I_d = 7\text{ A}$ $V_{gen} = 10\text{ V } R_{gen} = 10\ \Omega$ (see <a href="#">Figure 26</a> )		60	120	ns
	Rise time			160	300	ns
	Turn-off delay time			250	400	ns
	Fall time			100	200	ns
$t_{d(on)}$ $t_r$ $t_{d(off)}$ $t_f$	Turn-on delay time	$V_{DD} = 15\text{ V } I_d = 7\text{ A}$ $V_{gen} = 10\text{ V } R_{gen} = 1000\ \Omega$ (see <a href="#">Figure 26</a> )		300	500	ns
	Rise time			1.5	2.2	$\mu\text{s}$
	Turn-off delay time			5.5	7.5	$\mu\text{s}$
	Fall time			1.8	2.5	$\mu\text{s}$
$(di/dt)_{on}$	Turn-on current slope	$V_{DD} = 15\text{ V } I_D = 7\text{ A}$ $V_{in} = 10\text{ V } R_{gen} = 10\ \Omega$		120		A/ $\mu\text{s}$
$Q_i$	Total input charge	$V_{DD} = 12\text{ V } I_D = 7\text{ A } V_{in} = 10\text{ V}$		30		nC
<b>Source drain diode</b>						
$V_{SD}^{(1)}$	Forward on voltage	$I_{SD} = 7\text{ A } V_{in} = 0$			1.6	V
$t_{rr}^{(2)}$ $Q_{rr}^{(2)}$	Reverse recovery time	$I_{SD} = 7\text{ A } di/dt = 100\text{ A}/\mu\text{s}$ $V_{DD} = 30\text{ V } T_j = 25\text{ }^\circ\text{C}$ (see test circuit, <a href="#">Figure 28</a> )		110		ns
	Reverse recovery charge			0.34		$\mu\text{C}$
$I_{RRM}^{(2)}$	Reverse recovery current			6.1		A
<b>Protection</b>						
$I_{lim}$	Drain current limit	$V_{in} = 10\text{ V } V_{DS} = 13\text{ V}$	10	14	20	A
		$V_{in} = 5\text{ V } V_{DS} = 13\text{ V}$	10	14	20	A
$t_{dlim}^{(2)}$	Step response	$V_{in} = 10\text{ V}$		30	60	$\mu\text{s}$
	Current limit	$V_{in} = 5\text{ V}$		80	150	$\mu\text{s}$
$T_{jsh}^{(2)}$	Overtemperature shutdown		150			$^\circ\text{C}$
$T_{jrs}^{(2)}$	Overtemperature reset		135			$^\circ\text{C}$

Table 4. Electrical characteristics (continued)

Symbol	Parameter	Test conditions	Min.	Typ.	Max.	Unit
$I_{gf}^{(2)}$	Fault sink current	$V_{in} = 10\text{ V } V_{DS} = 13\text{ V}$ $V_{in} = 5\text{ V } V_{DS} = 13\text{ V}$		50 20		mA mA
$E_{as}^{(2)}$	Single pulse avalanche energy	starting $T_j = 25^\circ\text{C } V_{DD} = 20\text{ V}$ $V_{in} = 10\text{ V } R_{gen} = 1\text{ K}\Omega L = 10\text{ mH}$	0.65			J

1. Pulsed: Pulse duration = 300  $\mu\text{s}$ , duty cycle 1.5 %
2. Parameters guaranteed by design/characterization

Obsolete Product(s) - Obsolete Product(s)

### 3 Protection features

During normal operation, the Input pin is electrically connected to the gate of the internal power MOSFET. The device then behaves like a standard power MOSFET and can be used as a switch from DC to 50 kHz. The only difference from the user's standpoint is that a small DC current ( $I_{ISS}$ ) flows into the Input pin in order to supply the internal circuitry.

The device integrates:

- Overvoltage clamp protection: internally set at 42 V, along with the rugged avalanche characteristics of the Power MOSFET stage give this device unrivalled ruggedness and energy handling capability. This feature is mainly important when driving inductive loads.
- Linear current limiter circuit: limits the drain current  $I_D$  to  $I_{lim}$  whatever the Input pin voltage. When the current limiter is active, the device operates in the linear region, so power dissipation may exceed the capability of the heatsink. Both case and junction temperatures increase, and if this phase lasts long enough, junction temperature may reach the overtemperature threshold  $T_{jsh}$ .
- Overtemperature and short circuit protection: these are based on sensing the chip temperature and are not dependent on the input voltage. The location of the sensing element on the chip in the power stage area ensures fast, accurate detection of the junction temperature. Overtemperature cutout occurs at minimum 150 °C. The device is automatically restarted when the chip temperature falls below 135 °C.
- Status feedback: in the case of an overtemperature fault condition, a Status Feedback is provided through the Input pin. The internal protection circuit disconnects the input from the gate and connects it instead to ground via an equivalent resistance of 100 Ω. The failure can be detected by monitoring the voltage at the Input pin, which will be close to ground potential.

Additional features of this device are ESD protection according to the Human Body model and the ability to be driven from a TTL Logic circuit (with a small increase in  $R_{DS(on)}$ ).

Figure 2. Thermal impedance for D2PAK/PowerSO-10

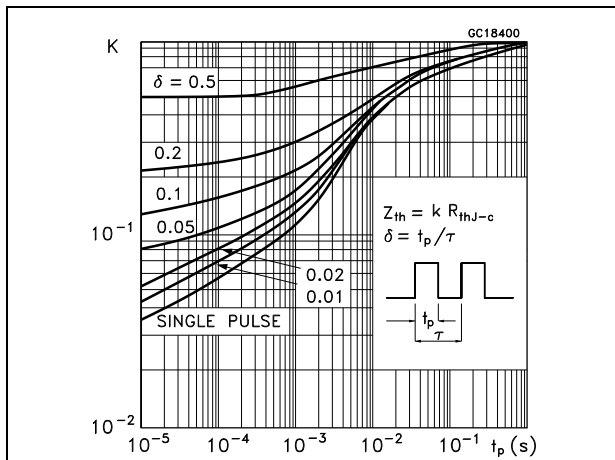

Figure 3. Derating curve

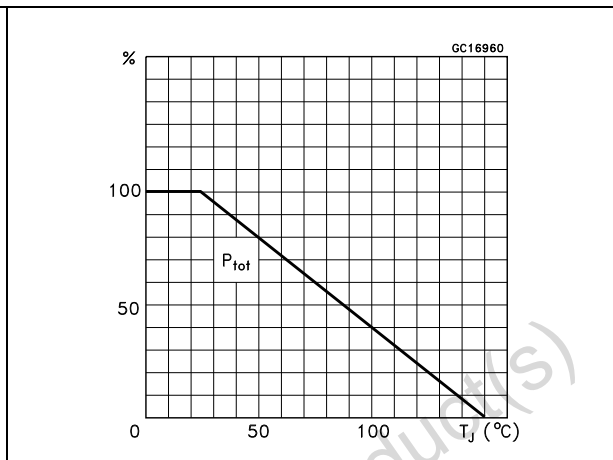

Figure 4. Output characteristics

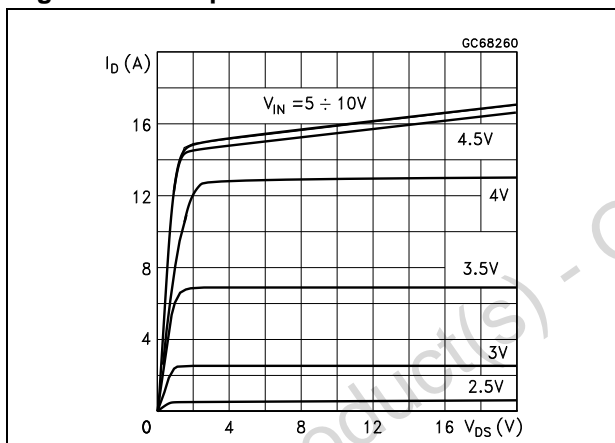

Figure 5. Transconductance

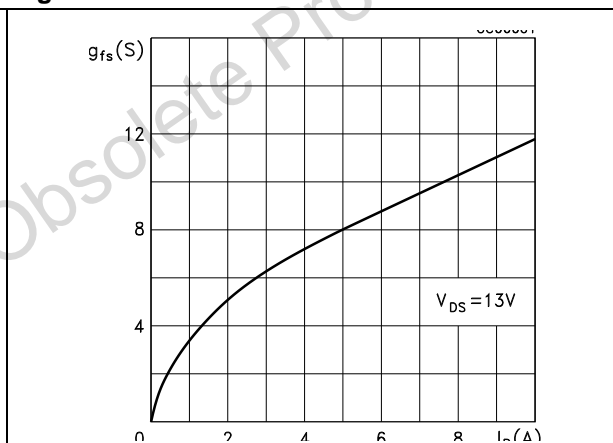

Figure 6. Static drain-source on resistance vs input voltage

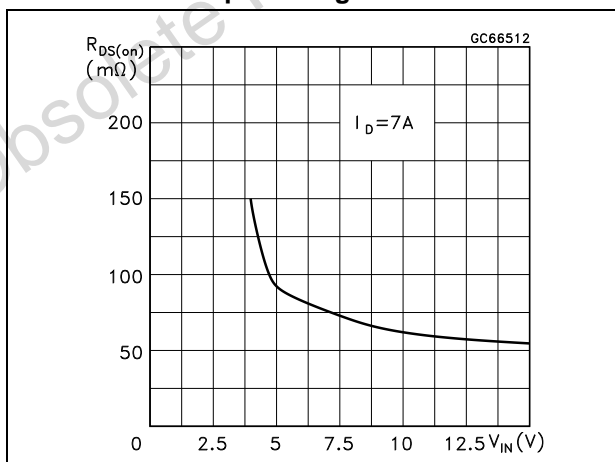

Figure 7. Static drain-source on resistance (part 1/2)

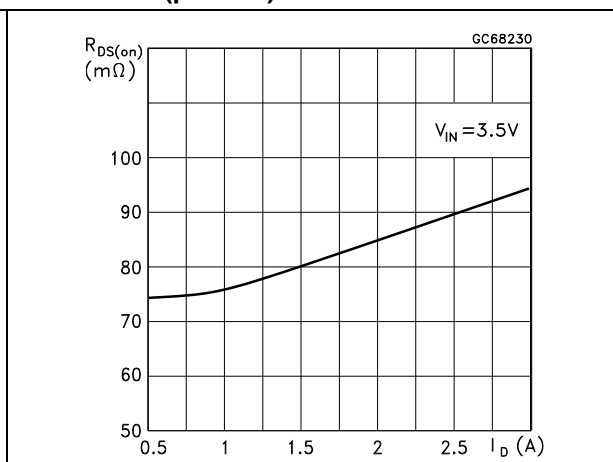



Figure 8. Static drain-source on resistance (part 2/2)

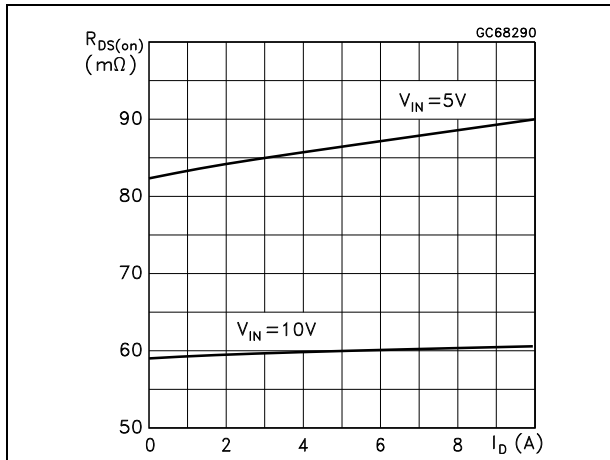

Figure 9. Input charge vs input voltage

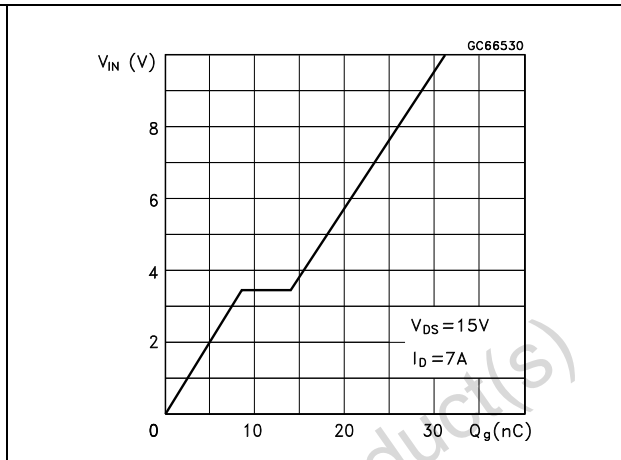

Figure 10. Capacitance variations

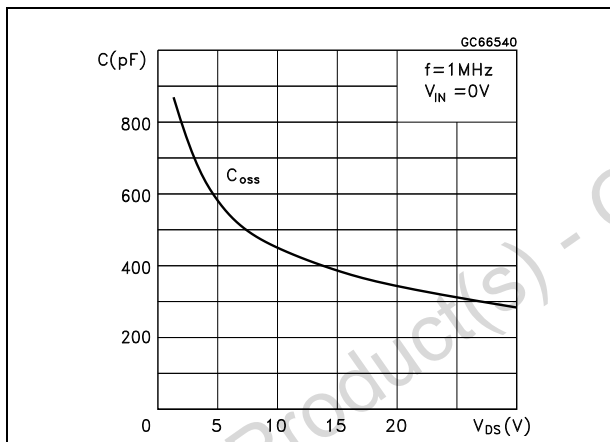

Figure 11. Normalized input threshold voltage vs temperature

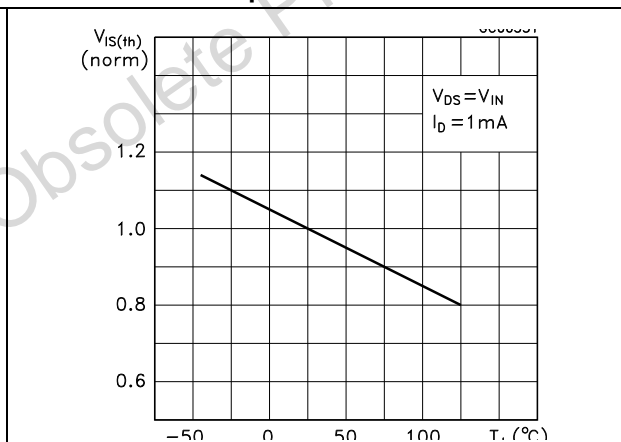

Figure 12. Normalized on resistance vs temperature (part 1/2)

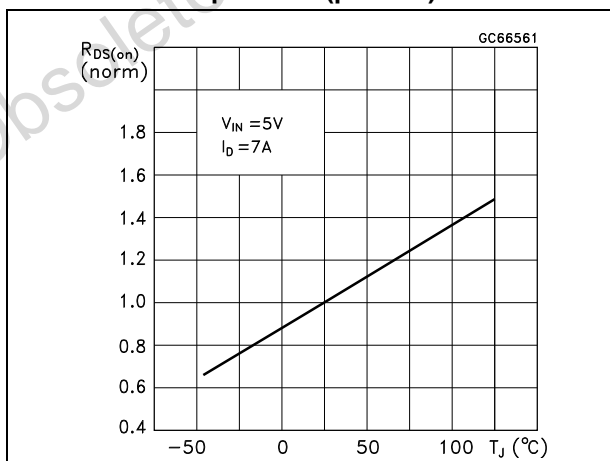

Figure 13. Normalized on resistance vs temperature (part 2/2)

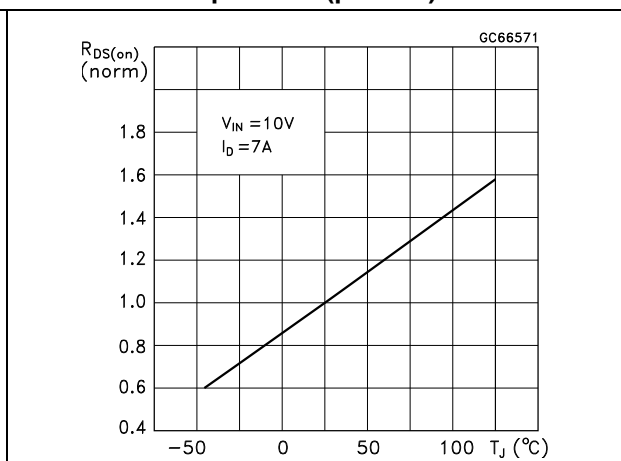

Figure 14. Turn-on current slope(part 1/2)

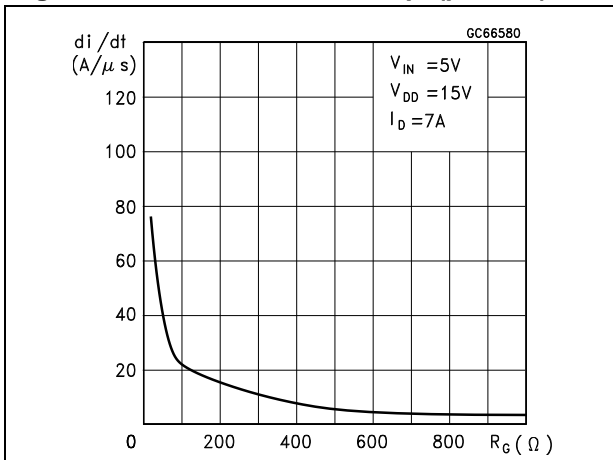

Figure 15. Turn-on current slope (part 2/2)

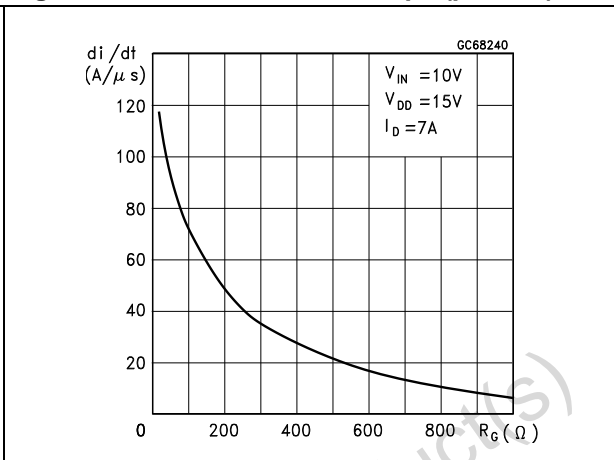

Figure 16. Turn-off drain-source voltage slope (part 1/2)

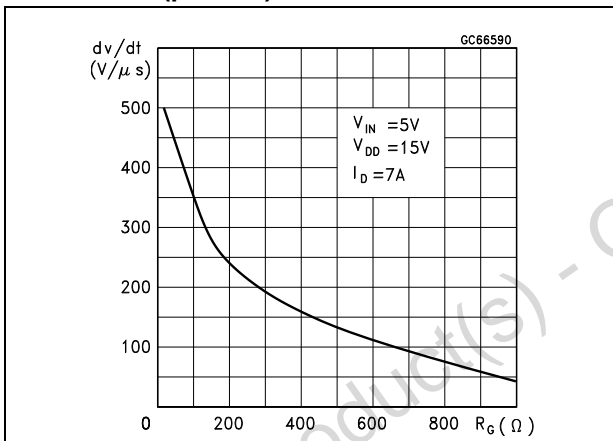

Figure 17. Turn-off drain-source voltage slope (part 2/2)

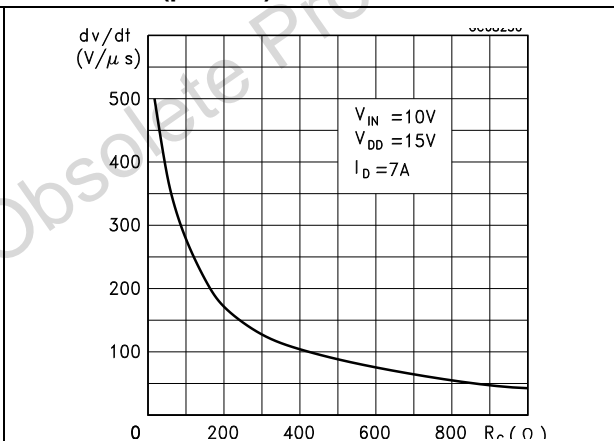

Figure 18. Switching time resistive load (part 1/3)

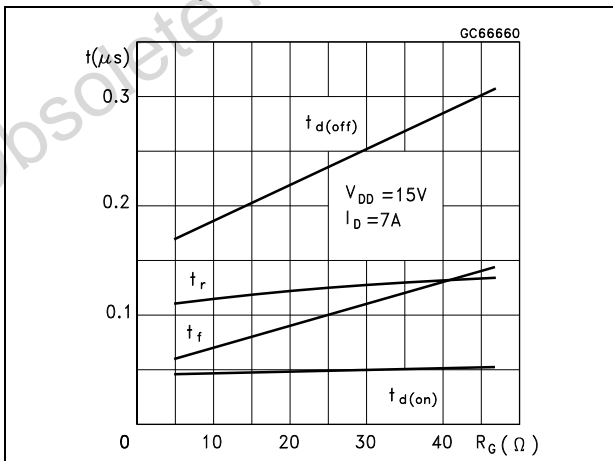

Figure 19. Switching time resistive load (part 2/3)

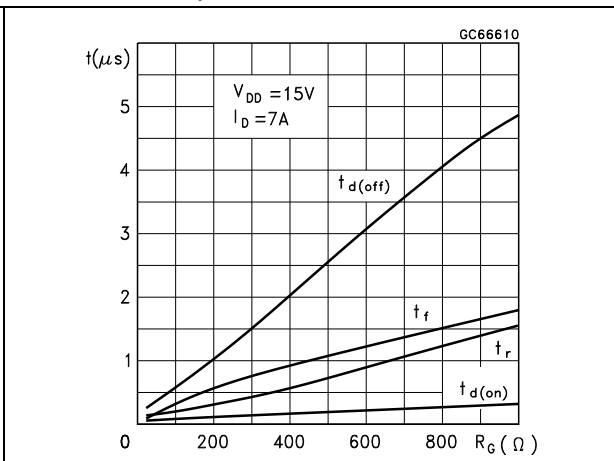

Figure 20. Switching time resistive load (part 3/3)

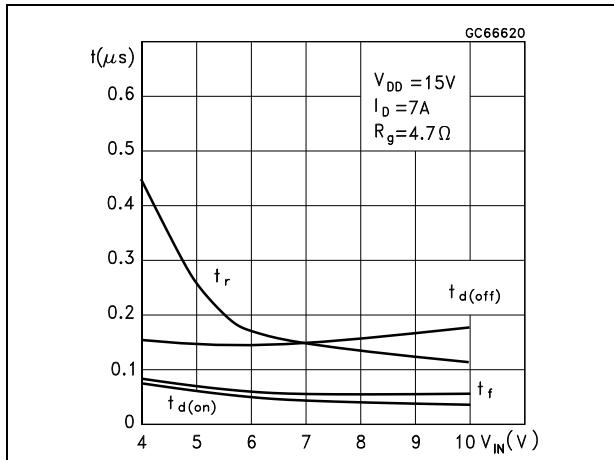

Figure 22. Step response current limit

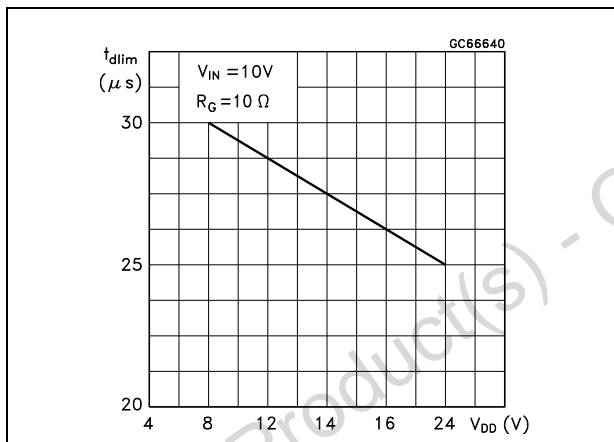

Figure 21. Current limit vs junction temperature

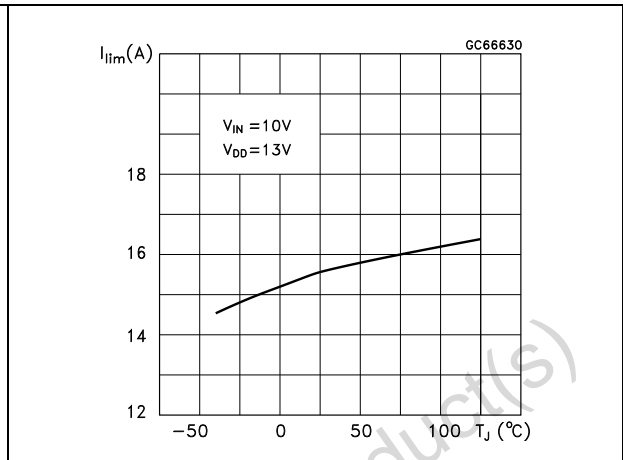

Figure 23. Source drain diode forward characteristics

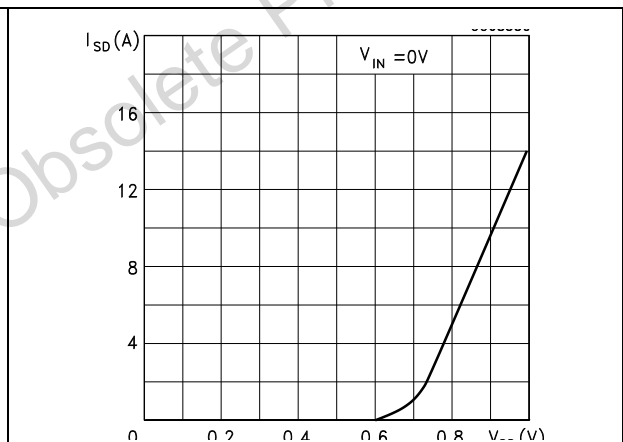

Figure 24. Unclamped inductive load test circuits

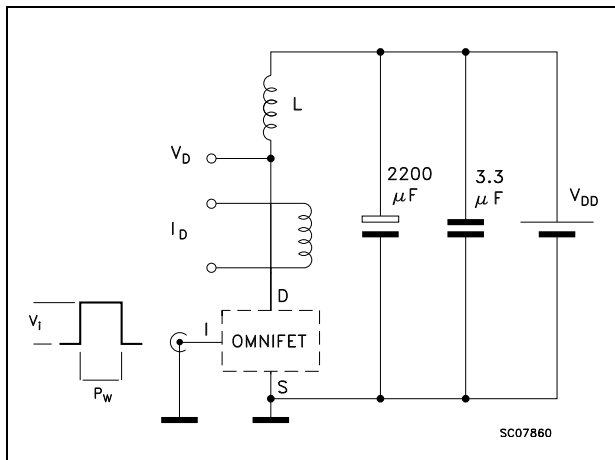

Figure 25. Unclamped inductive waveforms

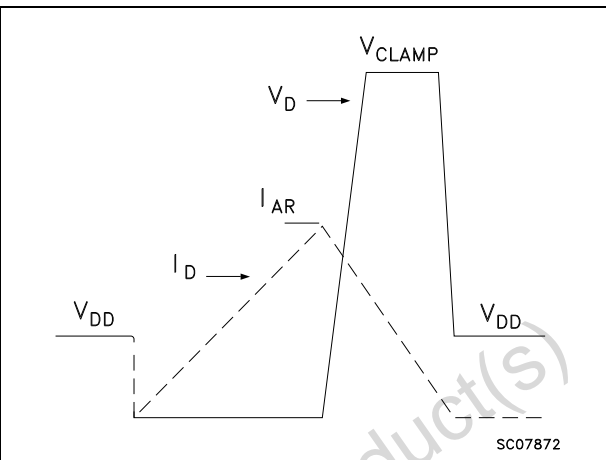

Figure 26. Switching times test circuits for resistive load

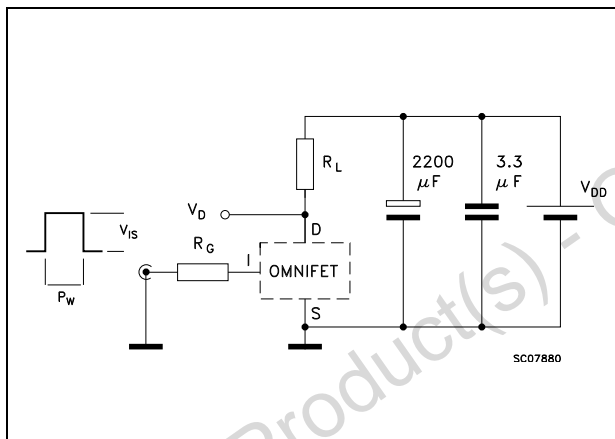

Figure 27. Input charge test circuit

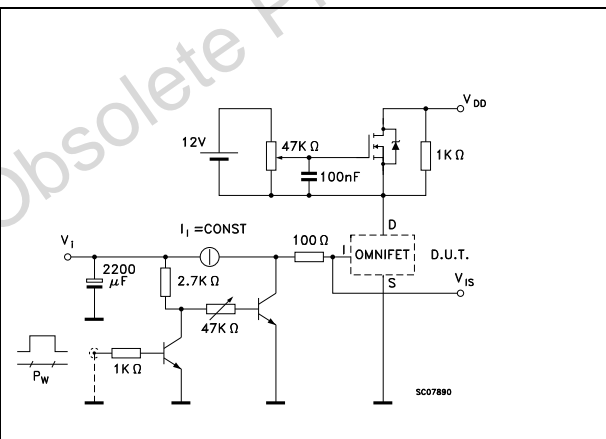

Figure 28. Test circuit for inductive load switching and diode recovery times

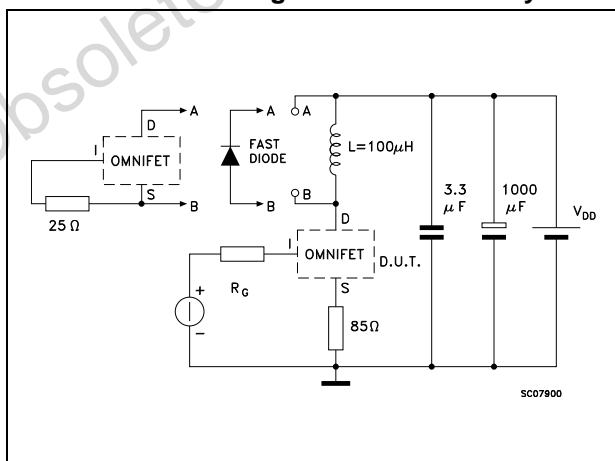
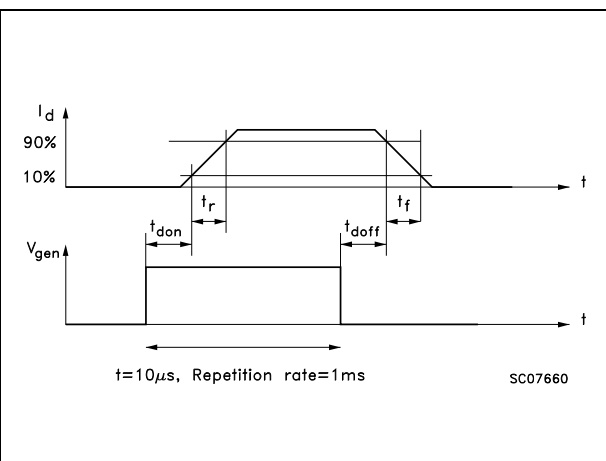

Figure 29. Waveforms



## 4 Package information

In order to meet environmental requirements, ST offers these devices in different grades of ECOPACK® packages, depending on their level of environmental compliance. ECOPACK® specifications, grade definitions and product status are available at: [www.st.com](http://www.st.com).

ECOPACK® is an ST trademark.

**Figure 30. TO-263 (D2PAK) mechanical data**

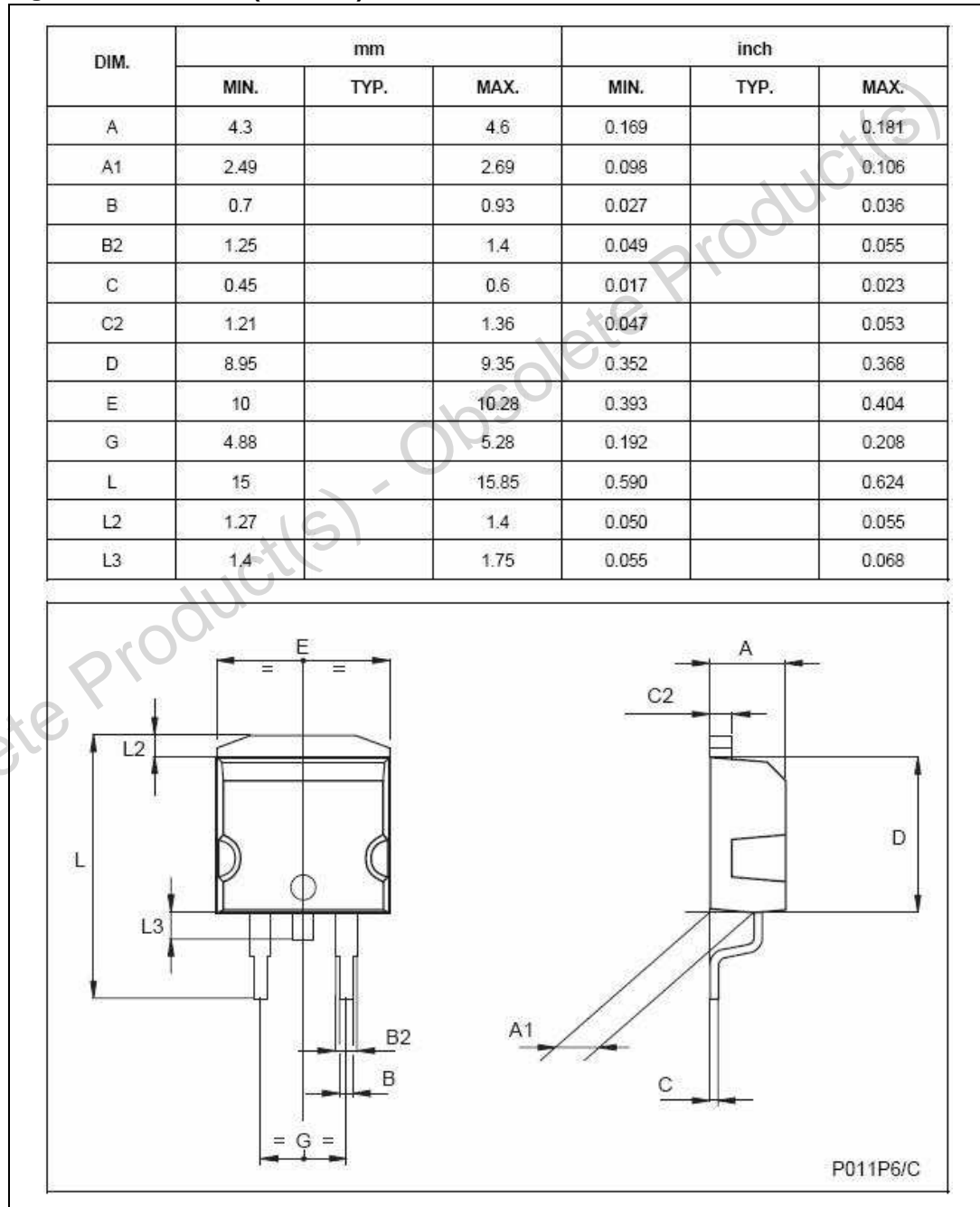

Figure 31. SOT82-FM mechanical data

DIM.	mm			inch		
	MIN.	TYP.	MAX.	MIN.	TYP.	MAX.
A	2.85		3.05	1.122		1.200
A1	1.47		1.67	0.578		0.657
b	0.40		0.60	0.157		0.236
b1	1.4		1.6	0.551		0.630
b2	1.3		1.5	0.511		0.590
c	0.45		0.6	0.177		0.236
D	10.5		10.9	4.133		4.291
e	2.2		2.8	0.866		1.102
E	7.45		7.75	2.933		3.051
L	15.5		15.9	6.102		6.260
L1	1.95		2.35	0.767		0.925

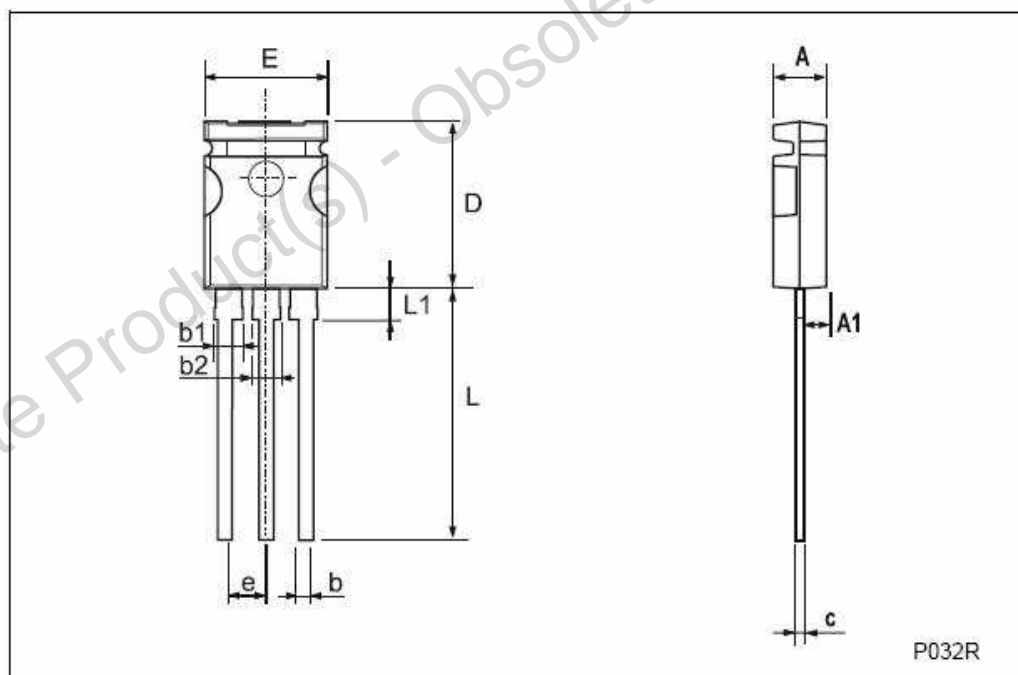
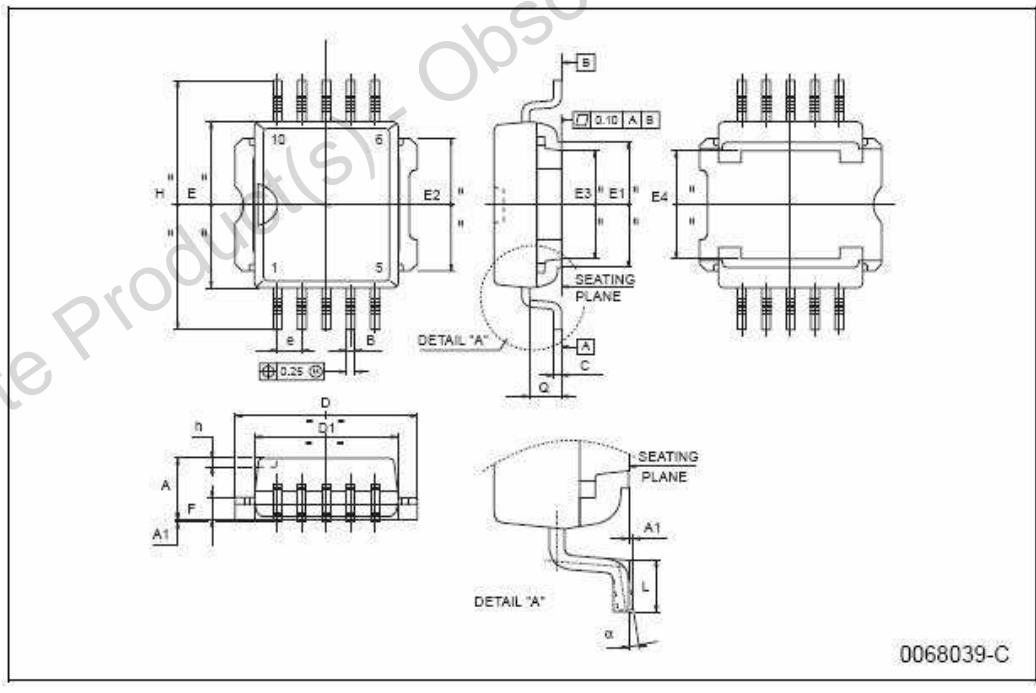

Figure 32. PowerSO-10 mechanical data

DIM.	mm			inch		
	MIN.	TYP.	MAX.	MIN.	TYP.	MAX.
A	3.35		3.65	0.132		0.144
A1	0.00		0.10	0.000		0.004
B	0.40		0.60	0.016		0.024
c	0.35		0.55	0.013		0.022
D	9.40		9.60	0.370		0.378
D1	7.40		7.60	0.291		0.300
E	9.30		9.50	0.366		0.374
E1	7.20		7.40	0.283		0.291
E2	7.20		7.60	0.283		0.300
E3	6.10		6.35	0.240		0.250
E4	5.90		6.10	0.232		0.240
e		1.27			0.050	
F	1.25		1.35	0.049		0.053
H	13.80		14.40	0.543		0.567
h		0.50			0.002	
L	1.20		1.80	0.047		0.071
q		1.70			0.067	
$\alpha$	$0^\circ$		$8^\circ$			



## 5 Revision history

**Table 5. Document revision history**

Date	Revision	Changes
20-Jan-1998	1	Initial release.
21-Jun-2004	5	Update.
08-Apr-2009	6	Document reformatted. Added <a href="#">Table 1: Device summary on page 1</a> . Updated <a href="#">Section 4: Package information on page 13</a>
25-Sep-2013	7	Updated Disclaimer.



**Please Read Carefully:**

Information in this document is provided solely in connection with ST products. STMicroelectronics NV and its subsidiaries ("ST") reserve the right to make changes, corrections, modifications or improvements, to this document, and the products and services described herein at any time, without notice.

All ST products are sold pursuant to ST's terms and conditions of sale.

Purchasers are solely responsible for the choice, selection and use of the ST products and services described herein, and ST assumes no liability whatsoever relating to the choice, selection or use of the ST products and services described herein.

No license, express or implied, by estoppel or otherwise, to any intellectual property rights is granted under this document. If any part of this document refers to any third party products or services it shall not be deemed a license grant by ST for the use of such third party products or services, or any intellectual property contained therein or considered as a warranty covering the use in any manner whatsoever of such third party products or services or any intellectual property contained therein.

**UNLESS OTHERWISE SET FORTH IN ST'S TERMS AND CONDITIONS OF SALE ST DISCLAIMS ANY EXPRESS OR IMPLIED WARRANTY WITH RESPECT TO THE USE AND/OR SALE OF ST PRODUCTS INCLUDING WITHOUT LIMITATION IMPLIED WARRANTIES OF MERCHANTABILITY, FITNESS FOR A PARTICULAR PURPOSE (AND THEIR EQUIVALENTS UNDER THE LAWS OF ANY JURISDICTION), OR INFRINGEMENT OF ANY PATENT, COPYRIGHT OR OTHER INTELLECTUAL PROPERTY RIGHT.**

**ST PRODUCTS ARE NOT DESIGNED OR AUTHORIZED FOR USE IN: (A) SAFETY CRITICAL APPLICATIONS SUCH AS LIFE SUPPORTING, ACTIVE IMPLANTED DEVICES OR SYSTEMS WITH PRODUCT FUNCTIONAL SAFETY REQUIREMENTS; (B) AERONAUTIC APPLICATIONS; (C) AUTOMOTIVE APPLICATIONS OR ENVIRONMENTS, AND/OR (D) AEROSPACE APPLICATIONS OR ENVIRONMENTS. WHERE ST PRODUCTS ARE NOT DESIGNED FOR SUCH USE, THE PURCHASER SHALL USE PRODUCTS AT PURCHASER'S SOLE RISK, EVEN IF ST HAS BEEN INFORMED IN WRITING OF SUCH USAGE, UNLESS A PRODUCT IS EXPRESSLY DESIGNATED BY ST AS BEING INTENDED FOR "AUTOMOTIVE, AUTOMOTIVE SAFETY OR MEDICAL" INDUSTRY DOMAINS ACCORDING TO ST PRODUCT DESIGN SPECIFICATIONS. PRODUCTS FORMALLY ESCC, QML OR JAN QUALIFIED ARE DEEMED SUITABLE FOR USE IN AEROSPACE BY THE CORRESPONDING GOVERNMENTAL AGENCY.**

Resale of ST products with provisions different from the statements and/or technical features set forth in this document shall immediately void any warranty granted by ST for the ST product or service described herein and shall not create or extend in any manner whatsoever, any liability of ST.

ST and the ST logo are trademarks or registered trademarks of ST in various countries.

Information in this document supersedes and replaces all information previously supplied.

The ST logo is a registered trademark of STMicroelectronics. All other names are the property of their respective owners.

© 2013 STMicroelectronics - All rights reserved

STMicroelectronics group of companies

Australia - Belgium - Brazil - Canada - China - Czech Republic - Finland - France - Germany - Hong Kong - India - Israel - Italy - Japan - Malaysia - Malta - Morocco - Philippines - Singapore - Spain - Sweden - Switzerland - United Kingdom - United States of America

[www.st.com](http://www.st.com)

