

OMNIFET III fully protected low-side driver

Datasheet - production data

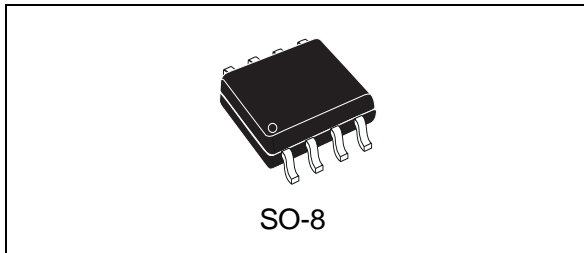

Description

The VNLD5160-E is a monolithic device made using STMicroelectronics® VIPower® technology, intended for driving resistive or inductive loads with one side connected to the battery. Built-in thermal shutdown protects the chip from overtemperature and short-circuit. Output current limitation protects the device in an overload condition. In case of long duration overload, the device limits the dissipated power to a safe level up to thermal shutdown intervention. Thermal shutdown, with automatic restart, allows the device to recover normal operation as soon as a fault condition disappears. Fast demagnetization of inductive loads is achieved at turn-off.

Features

Type	V _{clamp}	R _{DS(on)}	I _D
VNLD5160-E	41 V	160 mΩ	3.5 A

- Automotive qualified
- Drain current: 3.5 A
- ESD protection
- Overvoltage clamp
- Thermal shutdown
- Current and power limitation
- Very low standby current
- Very low electromagnetic susceptibility
- Compliant with European directive 2002/95/EC
- Open drain status output
- Specially intended for R10W or 2xR5W automotive signal lamps

Table 1. Devices summary

Package	Order codes	
	Tube	Tape and reel
SO-8	VNLD5160-E	VNLD5160TR-E

Contents

1	Block diagrams and pins configurations	5
2	Electrical specifications	7
2.1	Absolute maximum ratings	7
2.2	Thermal data	7
2.3	Electrical characteristics	8
3	Application information	11
3.1	MCU I/O protection	11
4	Package and PC board thermal data	13
4.1	SO-8 thermal data	13
5	Package and packing information	16
5.1	SO-8 package information	16
5.2	SO-8 packing information	18
6	Revision history	19

List of tables

Table 1.	Devices summary	1
Table 2.	Pin function	5
Table 3.	Suggested connections for unused and n.c. pins	6
Table 4.	Absolute maximum ratings	7
Table 5.	Thermal data	7
Table 6.	PowerMOS section	8
Table 7.	Source drain diode	8
Table 8.	Input section.	8
Table 9.	Status pin	8
Table 10.	Switching characteristics	9
Table 11.	Protection and diagnostics	9
Table 12.	Truth table.	10
Table 13.	Thermal parameters	15
Table 14.	SO-8 mechanical data	17
Table 15.	Document revision history	19

List of figures

Figure 1.	Block diagram	5
Figure 2.	Current and voltage conventions	6
Figure 3.	Configuration diagrams (top view)	6
Figure 4.	Switching characteristics	10
Figure 5.	Application schematic	11
Figure 6.	Maximum demagnetization energy ($V_{CC} = 13.5\text{ V}$)	12
Figure 7.	SO-8 PC board	13
Figure 8.	Rthj-amb vs PCB copper area in open box free air condition	13
Figure 9.	SO-8 thermal impedance junction ambient single pulse	14
Figure 10.	Thermal fitting model of a LSD in SO-8	14
Figure 11.	SO-8 package outline	16
Figure 12.	SO-8 tube shipment (no suffix)	18
Figure 13.	SO-8 tape and reel shipment (suffix "TR")	18

1 Block diagrams and pins configurations

Figure 1. Block diagram

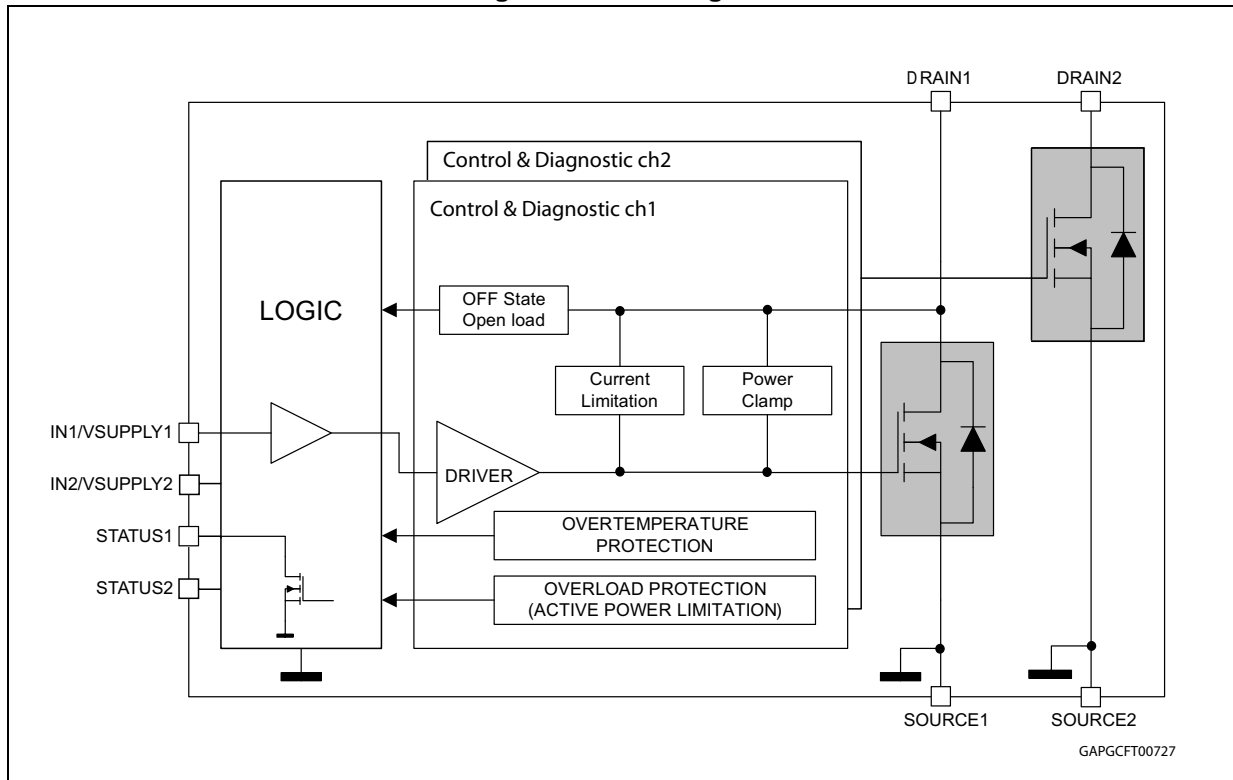

Table 2. Pin function

Name	Function
IN _{1,2} /VSUPPLY _{1,2}	Voltage controlled input pin with hysteresis, CMOS compatible. They control output switch state.
DRAIN _{1,2}	PowerMOS drain.
SOURCE _{1,2}	PowerMOS source and ground reference for the control section.
STATUS _{1,2}	Open drain digital diagnostic pin.

Figure 2. Current and voltage conventions

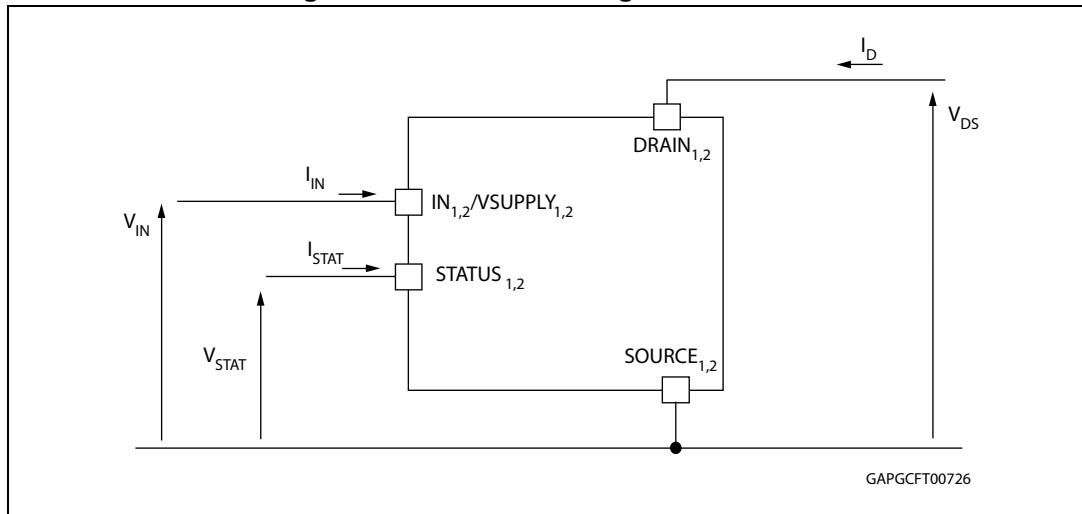

Figure 3. Configuration diagrams (top view)

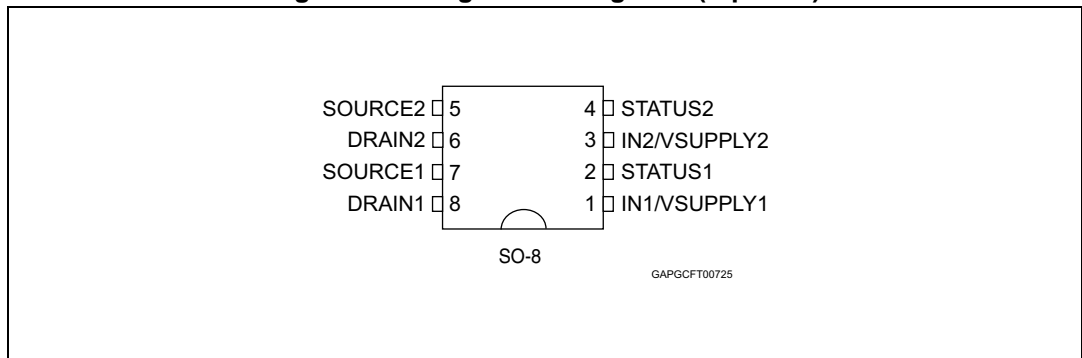

Table 3. Suggested connections for unused and n.c. pins

Connection / pin	STATUS _{1,2}	N.C.	INPUT _{1,2}
Floating	X ⁽¹⁾	X	X
To ground	Not allowed	X	Through 10 kΩ resistor

1. X: do not care.

2 Electrical specifications

2.1 Absolute maximum ratings

Stressing the device above the rating listed in the [Table 4](#) may cause permanent damage to the device. These are stress ratings only and operation of the device at these or any other conditions above those indicated in the operating sections of this specification is not implied. Exposure to absolute maximum rating conditions for extended periods may affect device reliability.

Table 4. Absolute maximum ratings

Symbol	Parameter	Value	Unit
V_{DS}	Drain-source voltage ($V_{IN} = 0$ V)	Internally clamped	V
I_D	DC drain current	Internally limited	A
$-I_D$	Reverse DC drain current	4	A
I_S	DC supply current	-1 to 10	mA
I_{IN}	DC input current	-1 to 10	mA
I_{STAT}	DC status current	-1 to 10	mA
V_{ESD1}	Electrostatic discharge ($R = 1.5$ k Ω ; $C = 100$ pF) – DRAIN – SUPPLY, INPUT, STATUS	5000 4000	V
V_{ESD2}	Electrostatic discharge on output pin only ($R = 330$ Ω , $C = 150$ pF)	2000	V
T_j	Junction operating temperature	-40 to 150	$^{\circ}$ C
T_{stg}	Storage temperature	-55 to 150	$^{\circ}$ C
E_{AS}	Single pulse avalanche energy ($L = 8.5$ mH, $T_J = 150$ $^{\circ}$ C, $R_L = 0$, $I_{OUT} = I_{limL}$)	37	mJ

2.2 Thermal data

Table 5. Thermal data

Symbol	Parameter	Maximum value	Unit
$R_{thj-amb}$	Thermal resistance junction-ambient	111.5	$^{\circ}$ C/W

2.3 Electrical characteristics

Values specified in this section are for $V_{supply} = V_{IN} = 4.5\text{ V to }5.5\text{ V}$, $-40\text{ °C} < T_j < 150\text{ °C}$, unless otherwise stated.

Table 6. PowerMOS section

Symbol	Parameter	Test conditions	Min.	Typ.	Max.	Unit
R _{ON}	ON-state resistance	I _D = 1 A; T _j = 25 °C, V _{supply} = V _{IN} = 5 V		160		mΩ
		I _D = 1 A; T _j = 150 °C, V _{supply} = V _{IN} = 5 V			320	
V _{CLAMP}	Drain-source clamp voltage	V _{IN} = 0 V; I _D = 1 A	41	46	52	V
V _{CLTH}	Drain-source clamp threshold voltage	V _{IN} = 0 V; I _D = 2 mA	36			V
I _{DSS}	OFF-state output current	V _{IN} = 0 V; V _{DS} = 13 V; T _j = 25 °C	0		3	μA
		V _{IN} = 0 V; V _{DS} = 13 V; T _j = 125 °C	0		5	

Table 7. Source drain diode

Symbol	Parameter	Test conditions	Min.	Typ.	Max.	Unit
V _{SD}	Forward on voltage	I _D = 1 A; V _{IN} = 0 V	—	0.8	—	V

Table 8. Input section

Symbol	Parameter	Test conditions	Min.	Typ.	Max.	Unit
I _{ISS}	Supply current from input pin	ON-state: V _{supply} = V _{IN} = 5 V; V _{DS} = 0 V		30	65	μA
V _{ICL}	Input clamp voltage	I _S = 1 mA	5.5		7	V
		I _S = -1 mA		-0.7		
V _{INTH}	Input threshold voltage	V _{DS} = V _{IN} ; I _D = 1 mA	1		3.5	V

Table 9. Status pin

Symbol	Parameter	Test conditions	Min.	Typ.	Max.	Unit
V _{STAT}	Status low output voltage	I _{STAT} = 1 mA			0.5	V
I _{LSTAT}	Status leakage current	Normal operation; V _{STAT} = 5 V			10	μA
C _{STAT}	Status pin input capacitance	Normal operation; V _{STAT} = 5 V			100	pF
V _{STCL}	Status clamp voltage	I _{STAT} = 1 mA	5.5		7	V
		I _{STAT} = -1 mA		-0.7		

Table 10. Switching characteristics

Symbol	Parameter	Test conditions	Min.	Typ.	Max.	Unit
$t_{d(ON)}$	Turn-on delay time	$R_L = 13 \Omega$; $V_{CC} = 13 V^{(1)}$	—	8.9	—	μs
$t_{d(OFF)}$	Turn-off delay time	$R_L = 13 \Omega$; $V_{CC} = 13 V^{(1)}$	—	13.2	—	μs
t_r	Rise time	$R_L = 13 \Omega$; $V_{CC} = 13 V^{(1)}$	—	14.1	—	μs
t_f	Fall time	$R_L = 13 \Omega$; $V_{CC} = 13 V^{(1)}$	—	11.5	—	μs
W_{ON}	Switching energy losses at turn-on	$R_L = 13 \Omega$; $V_{CC} = 13 V$	—	34.3	—	mJ
W_{OFF}	Switching energy losses at turn-off	$R_L = 13 \Omega$; $V_{CC} = 13 V$	—	34.3	—	mJ

1. See [Figure 4: Switching characteristics](#).

Table 11. Protection and diagnostics

Symbol	Parameter	Test conditions	Min.	Typ.	Max.	Unit
I_{limH}	DC short-circuit current	$V_{DS} = 13 V$; $V_{supply} = V_{IN} = 5 V$	3.5	5	7.5	A
I_{limL}	Short-circuit current during thermal cycling	$V_{DS} = 13 V$; $T_R < T_j < T_{TSD}$; $V_{supply} = V_{IN} = 5 V$		2.5		A
t_{dimL}	Step response current limit	$V_{DS} = 13 V$; $V_{input} = 5 V$		20		μs
T_{TSD}	Shutdown temperature		150	175	200	$^{\circ}C$
T_R	Reset temperature		$T_{RS} + 1$	$T_{RS} + 5$		$^{\circ}C$
T_{RS}	Thermal reset of STATUS		135			$^{\circ}C$
T_{HYST}	Thermal hysteresis ($T_{TSD} - T_R$)			7		$^{\circ}C$

Table 12. Truth table

Conditions	INPUT	DRAIN	STATUS
Normal operation	L	H	H
	H	L	H
Current limitation	L	H	H
	H	X	H
Overtemperature	L	H	H
	H	H	L
Undervoltage	L	H	X
	H	H	X

Figure 4. Switching characteristics

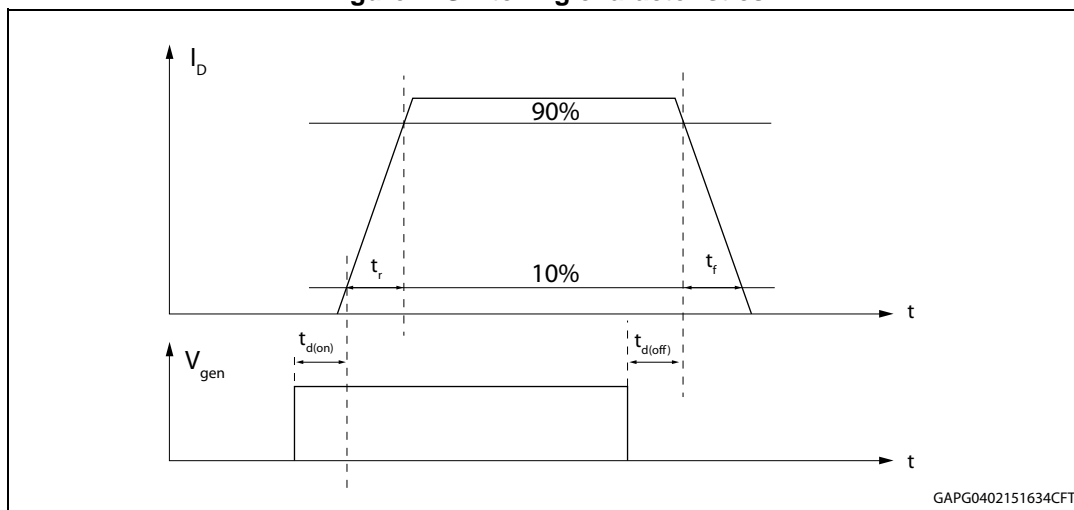

3 Application information

Figure 5. Application schematic

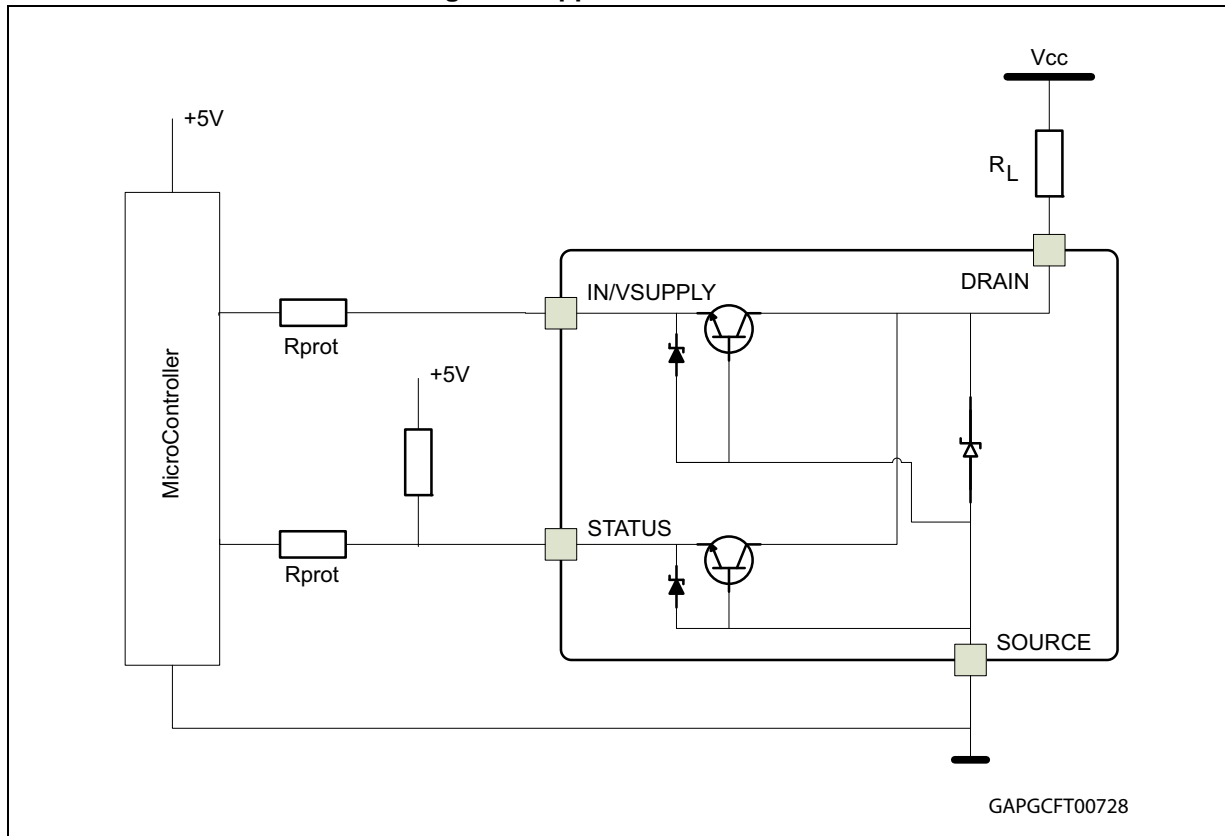

3.1 MCU I/O protection

ST suggests to insert a resistor (R_{prot}) in line to prevent the microcontroller I/O pins from latching up^(a). The value of these resistors is a compromise between the leakage current of microcontroller and the current required by the LSD I/Os (input levels compatibility) with the latch-up limit of microcontroller I/Os:

Equation 1

$$\frac{0.7}{I_{latchup}} \leq R_{prot} \leq \frac{(V_{OH\mu C} - V_{IH})}{I_{IH\ max}}$$

a. In case of negative transient on the drain pin.

Let:

- $I_{latchup} \geq 20 \text{ mA}$
- $V_{OH\mu C} \geq 4.5 \text{ V}$
- $35 \Omega \leq R_{prot} \leq 100 \text{ K}\Omega$

Then, the recommended value is $R_{prot} = 10 \text{ K}\Omega$

Figure 6 shows the turn-off current drawn during the demagnetization.

Figure 6. Maximum demagnetization energy ($V_{CC} = 13.5 \text{ V}$)

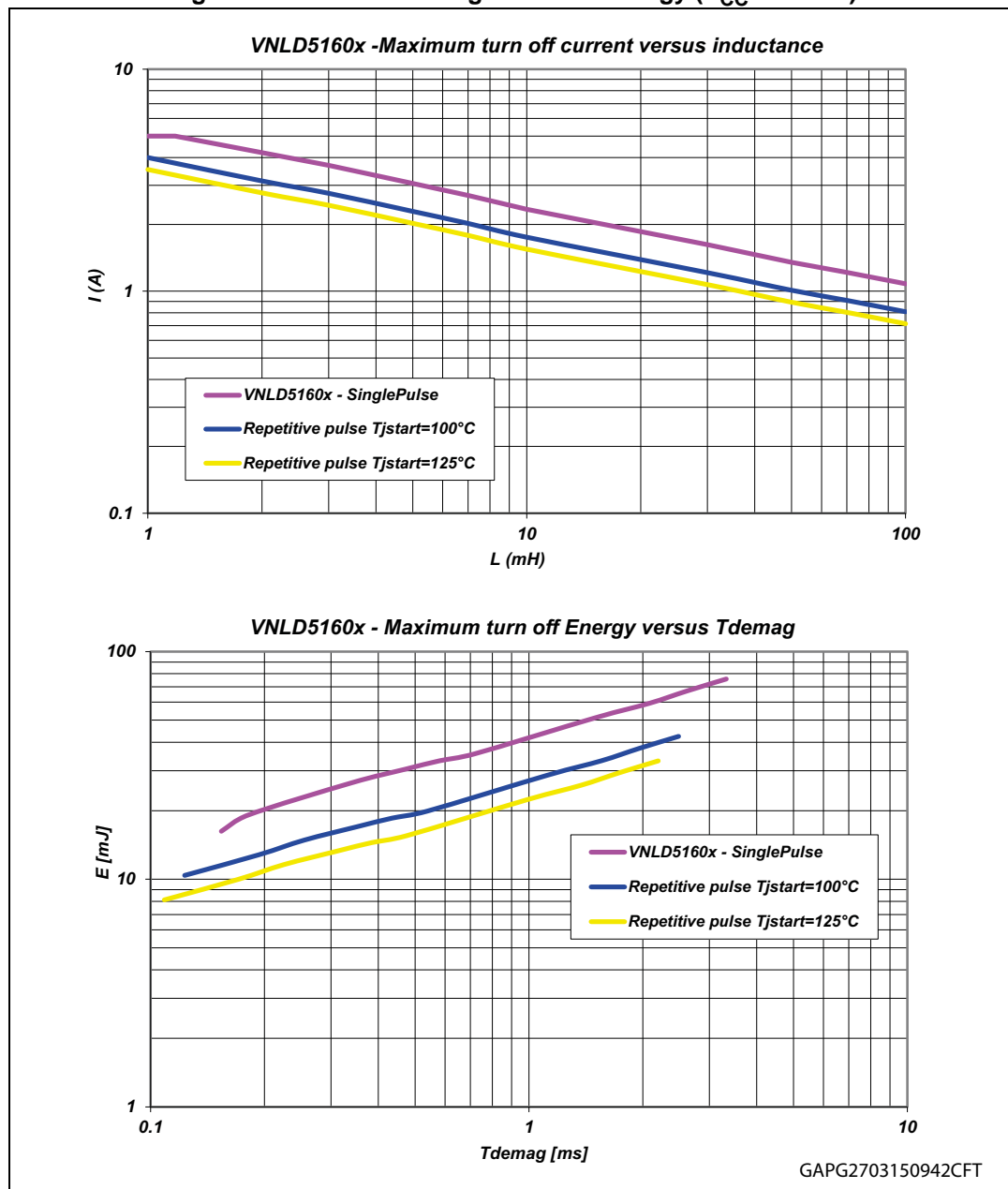

1. Values are generated with $R_{l} = 0\Omega$.
 In case of repetitive pulses, T_{jstart} (at the beginning of each demagnetization) of every pulse must not exceed the temperature specified above for curves A and B

4 Package and PC board thermal data

4.1 SO-8 thermal data

Figure 7. SO-8 PC board

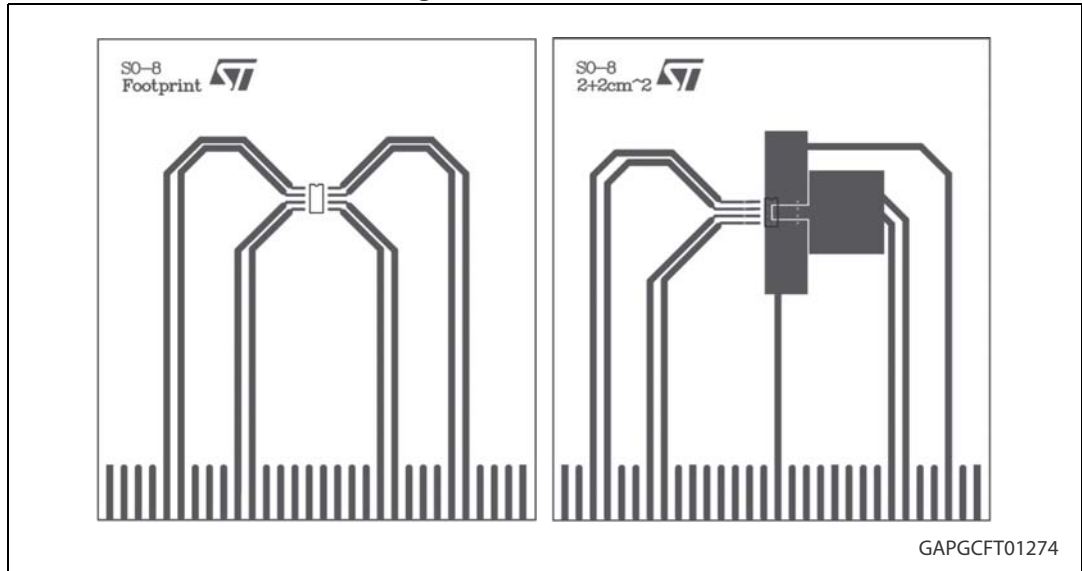

1. Layout condition of R_{th} and Z_{th} measurements (Board finish thickness 1.6 mm +/- 10%; Board double layer; Board dimension 78 mm x 86 mm; Board Material FR4; Cu thickness 0.070 mm (front and back side); Thermal vias separation 1.2 mm; Thermal via diameter 0.3 mm +/- 0.08 mm; Cu thickness on vias 0.025 mm).

Figure 8. $R_{thj-amb}$ vs PCB copper area in open box free air condition

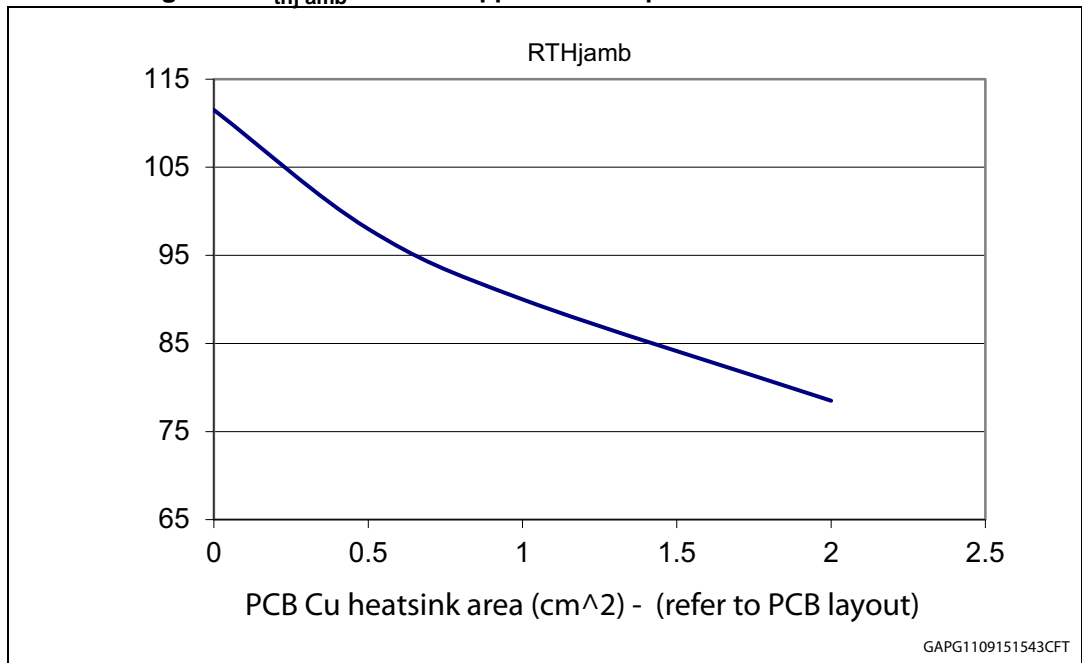
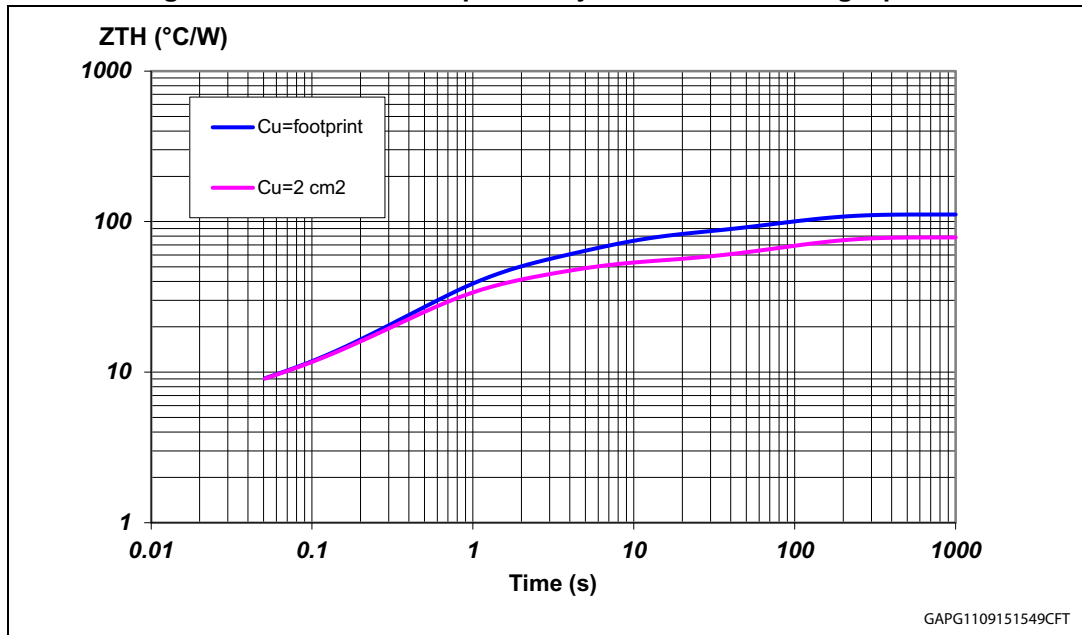

Figure 9. SO-8 thermal impedance junction ambient single pulse



Equation 2: pulse calculation formula

$$Z_{TH\delta} = R_{TH} \cdot \delta + Z_{THtp}(1 - \delta)$$

where $\delta = t_p/T$

Figure 10. Thermal fitting model of a LSD in SO-8

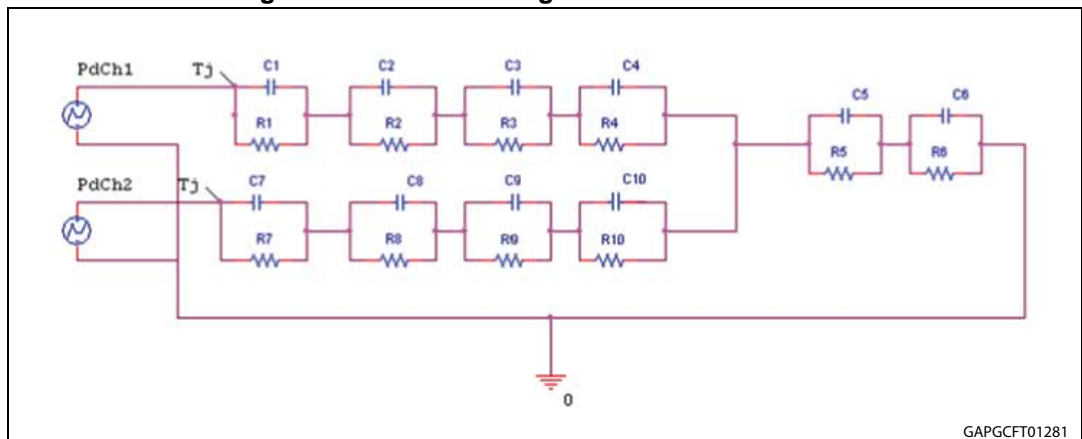

Note: The fitting model is a simplified thermal tool and is valid for transient evolutions where the embedded protections (power limitation or thermal cycling during thermal shutdown) are not triggered.

Table 13. Thermal parameters

Area/island (cm ²)	Footprint	2
R1 = R7 (°C/W)	1	1
R2 = R8 (°C/W)	2	2
R3 = R9 (°C/W)	3.5	3.5
R4 = R10 (°C/W)	34	25
R5 (°C/W)	36	20
R6 (°C/W)	35	27
C1 = C7 (W.s/°C)	0.00005	0.00005
C2 = C8 (W.s/°C)	0.002	0.002
C3 = C9 (W.s/°C)	0.005	0.005
C4 = C10 (W.s/°C)	0.02	0.02
C5 (W.s/°C)	0.15	0.15
C6 (W.s/°C)	2.5	3.5

5 Package and packing information

In order to meet environmental requirements, ST offers these devices in different grades of ECOPACK® packages, depending on their level of environmental compliance. ECOPACK® specifications, grade definitions and product status are available at: www.st.com. ECOPACK® is an ST trademark.

5.1 SO-8 package information

Figure 11. SO-8 package outline

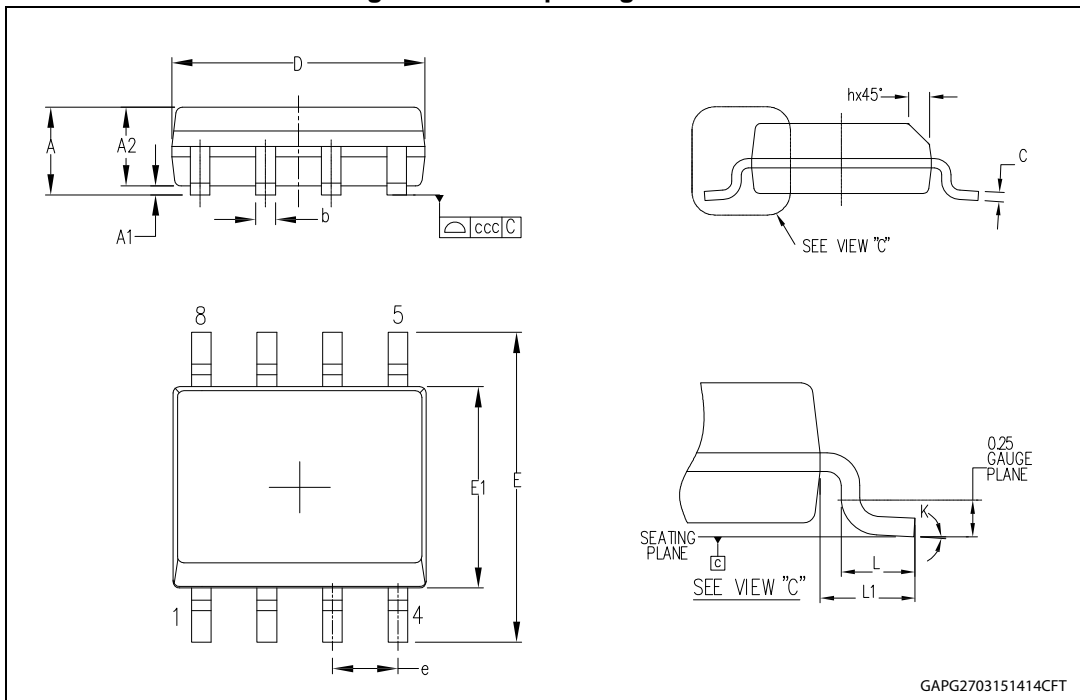

Table 14. SO-8 mechanical data

Symbol	Millimeters		
	Min.	Typ.	Max.
A			1.75
A1	0.10		0.25
A2	1.25		
b	0.28		0.48
c	0.17		0.23
D ⁽¹⁾	4.80	4.90	5.00
E	5.80	6.00	6.20
E1 ⁽²⁾	3.80	3.90	4.00
e		1.27	
h	0.25		0.50
L	0.40		1.27
L1		1.04	
k	0°		8°
ccc			0.10

1. Dimensions D does not include mold flash, protrusions or gate burrs. Mold flash, protrusions or gate burrs shall not exceed 0.15 mm in total (both side).
2. Dimension "E1" does not include interlead flash or protrusions. Interlead flash or protrusions shall not exceed 0.25 mm per side.

5.2 SO-8 packing information

Figure 12. SO-8 tube shipment (no suffix)

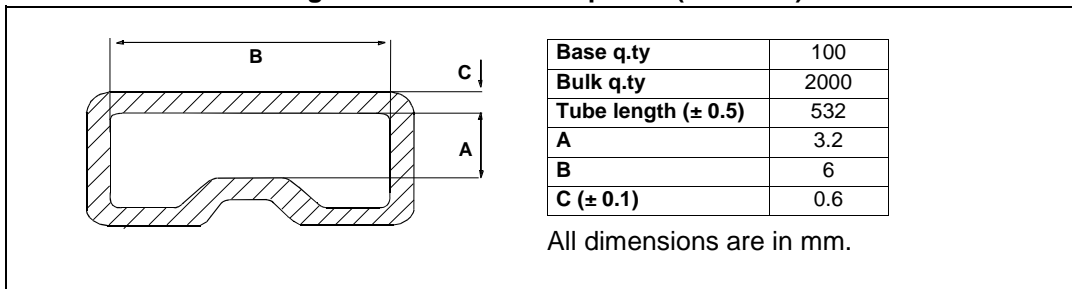
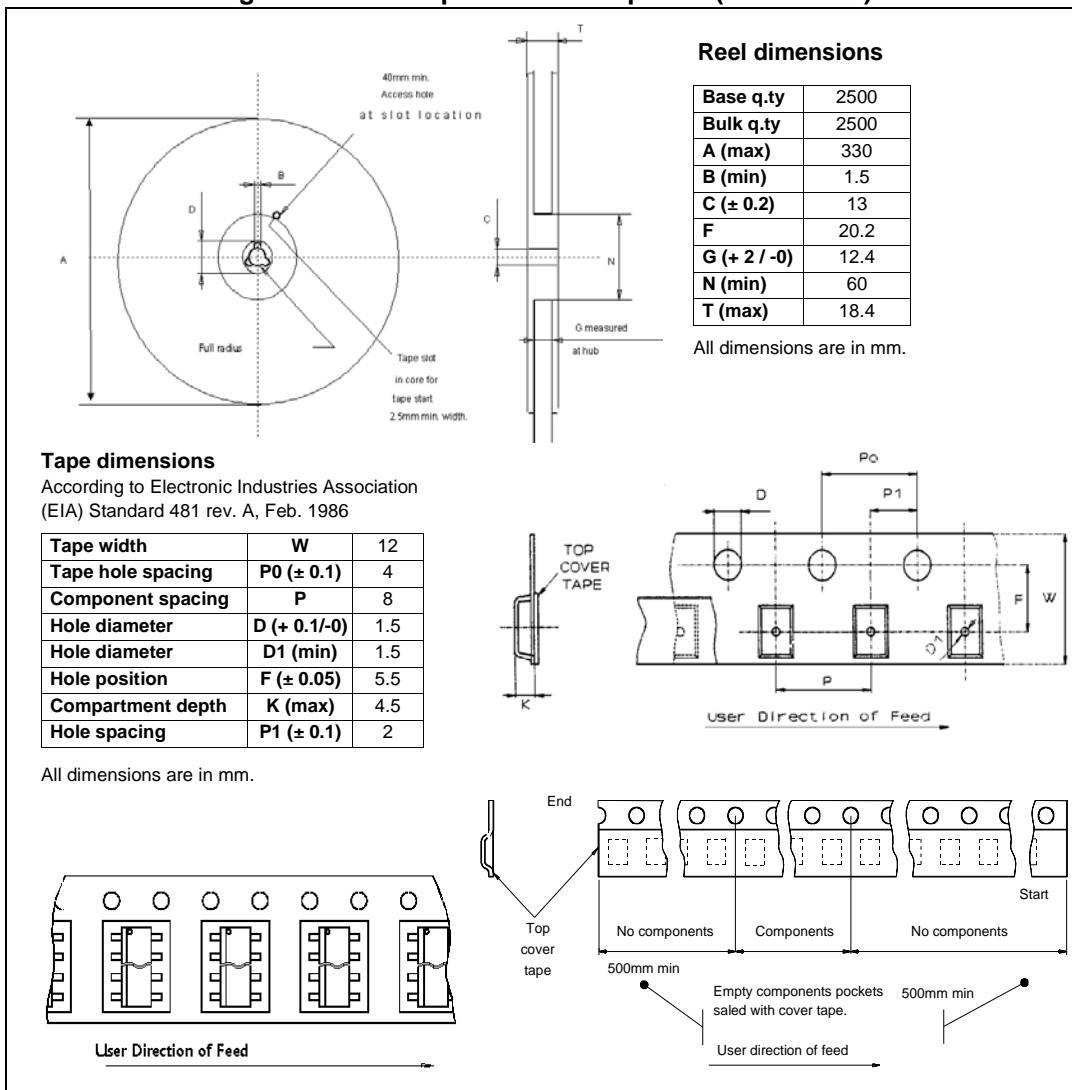

Figure 13. SO-8 tape and reel shipment (suffix “TR”)



6 Revision history

Table 15. Document revision history

Date	Revision	Changes
02-Apr-2015	1	Initial release.
14-Sep-2015	2	Updated Table 5: Thermal data Updated Chapter 4: Package and PC board thermal data

IMPORTANT NOTICE – PLEASE READ CAREFULLY

STMicroelectronics NV and its subsidiaries ("ST") reserve the right to make changes, corrections, enhancements, modifications, and improvements to ST products and/or to this document at any time without notice. Purchasers should obtain the latest relevant information on ST products before placing orders. ST products are sold pursuant to ST's terms and conditions of sale in place at the time of order acknowledgement.

Purchasers are solely responsible for the choice, selection, and use of ST products and ST assumes no liability for application assistance or the design of Purchasers' products.

No license, express or implied, to any intellectual property right is granted by ST herein.

Resale of ST products with provisions different from the information set forth herein shall void any warranty granted by ST for such product.

ST and the ST logo are trademarks of ST. All other product or service names are the property of their respective owners.

Information in this document supersedes and replaces information previously supplied in any prior versions of this document.

© 2015 STMicroelectronics – All rights reserved