

## FEATURES

- High quality voice & sound generation
- 10 messages with direct trigger pins
- Playback-only with external EPROM or ROM
- Stand-alone operation
- 128K x 8 direct memory addressing, expandable
- Single 5V DC supply voltage

- Low power consumption
- Internal RC oscillator or external clock
- Continuous Variable Slope Delta (CVSD) modulation
- Sampling rate from 24Kbps to 128 Kbps
- Message digitization with the VP-880 system
- 48-pin DIP (VP-1410A) or 48-pin QFP (VP-1410AF)

## GENERAL DESCRIPTIONS

The VP-1410A Digital Voice Processor is an advanced CMOS LSI chip designed for multiple-message playback applications. It can access up to 10 different messages of variable length stored in external EPROM or ROM chips. Message activation is simplified since each message has its own trigger pin. If memory bank switching technique is used, the number of messages supported can be easily expanded to 20, 40 or more.

The VP-1410A is totally self-contained. It can access the external memory all by itself without the help from any microprocessor. Although the chip provides only 16 address lines, an external counter can be easily added to extend the memory addressing to virtually no limitation. Therefore very long message length can be achieved easily. Overall, the VP-1410A offers high voice quality and flexible memory addressing that no other chips can.

## APPLICATIONS

- Multiple message playback
- Sound effects generator
- Digital message repeaters for consumer, industrial, security and telecommunication products

### VP-1410A (DIP48) Pin Assignment

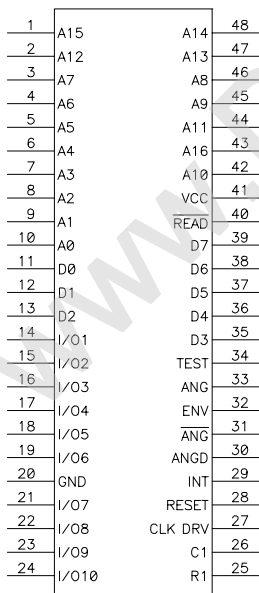

### VP-1410AF (QFP48) Pin Assignment

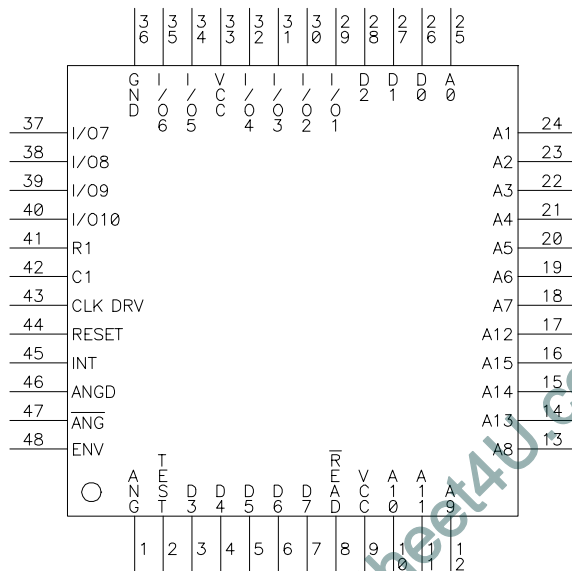

## ABSOLUTE MAXIMUM RATINGS\*

Supply Voltage, $V_{DD} - V_{SS}$ .....	0 to 5.5V
Input Volotage, $V_{IN}$ .....	$V_{SS}$ to $V_{DD}$
Operating Temperature, $T_{OP}$ .....	-10°C to 60°C
Storage Temperature, $T_{ST}$ .....	-20°C to 80°C

\* Stresses above those listed under "Absolute Maximum Ratings" may cause permanent damage to the device. This is a stress rating only and functional operation of the device at these or any other conditions above those indicated in the operational sections of this specification is not implied.

## ELECTRICAL CHARACTERISTICS

( $V_{DD} = 5V$ ,  $F_{OSC} = 2048KHZ$ ,  $F_{CLOCK} = 32 KHZ$  unless otherwise specified)

Symbol	Parameter		Min.	Typ.	Max.	Units
$V_{DD}$	Supply Voltage		4.5	5	5.5	V
$I_{DD}$	Standby Current			1.4		mA
$I_{DRIVE}$	Clock Drive Current		12			mA
$I_{SINK}$	Clock Sink Current		12			mA
$V_{IH}$	Input Voltage	High	3.5		5	V
$V_{IL}$		Low	0		1.5	V
$I_{DRIVE}$	Output Current	Drive	3	4		mA
$I_{SINK}$		Sink	3	4		mA
$T_{RESET}$	Reset Pulse Width		500			ns
$T_{tr}$	I/O Input Pulse Width			35		us
$F_C$	Internal Memory Search Clock			12		MHz

## TIMING DIAGRAM

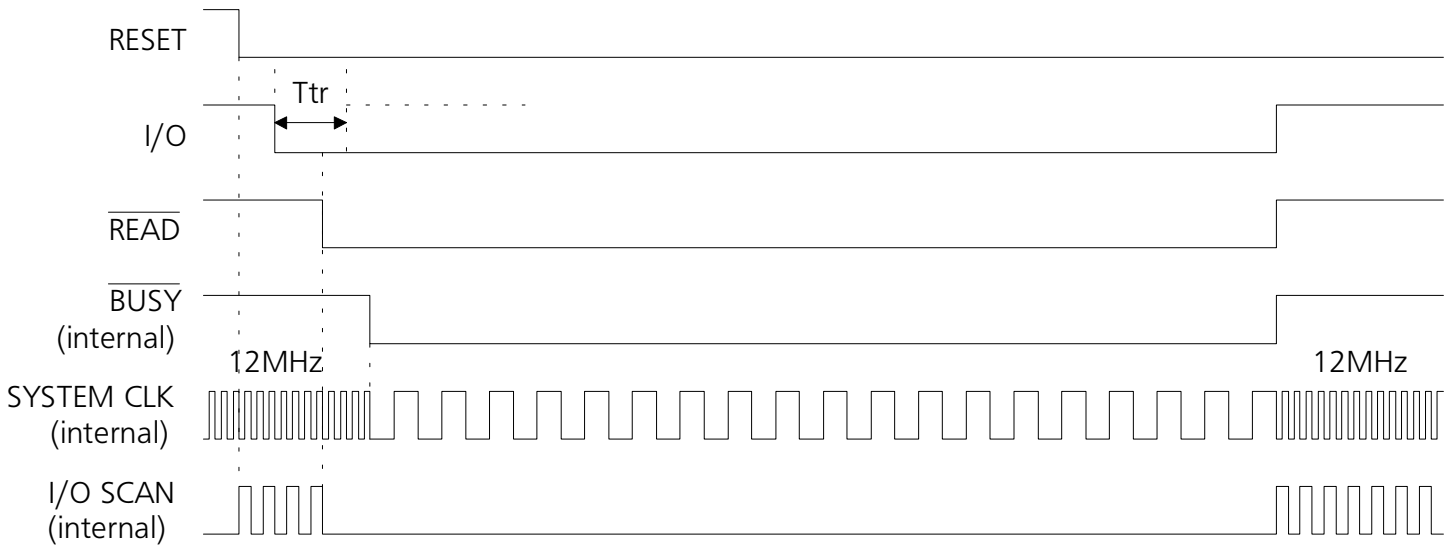

## PIN DESCRIPTIONS

### A0 - A16

Output, address bus, expandable by adding a counter. Note that VP-1410AF does not have A16.

### ANG & $\overline{\text{ANG}}$

Output, differential analog audio signal.

### ANGD

Input, analog signal to be connected to the external comparator output.

### C1

Input, internal RC oscillator. If external clock is to be used, it must be connected to this pin and its frequency 64x the sampling rate.

### CLK DRV

Output, buffered clock signal, a square wave of the same frequency as the sampling rate.

### D0 - D7

Input, data bus.

### ENV

Input, to be connected to an external integrator output.

### INT

Output, connected to an external integrator to produce envelope waveform.

### GND

Ground.

### I/O1 ~ I/O10

Input/output, trigger pin, active low. I/O1 is for message #1, I/O2 is for message #2 and etc. When the chip is idle but not under reset, this pin is the trigger input and pulsing it will put the chip in the "Play" mode and start the message. Once in the "Play" mode, the pin becomes a "low" output until the message is over.

### R1

Output, internal oscillator pin. Leave un-connected when using external clock.

### $\overline{\text{READ}}$

Output, active low. It indicates the chip is in the "Play" mode. This signal is usually used to enable memory output.

### RESET

Input, active high. Reset the chip back to the "Idle" mode. This pin is level sensitive.

### TEST

For factory use only, keep it un-connected.

### VCC

Input, supply voltage.

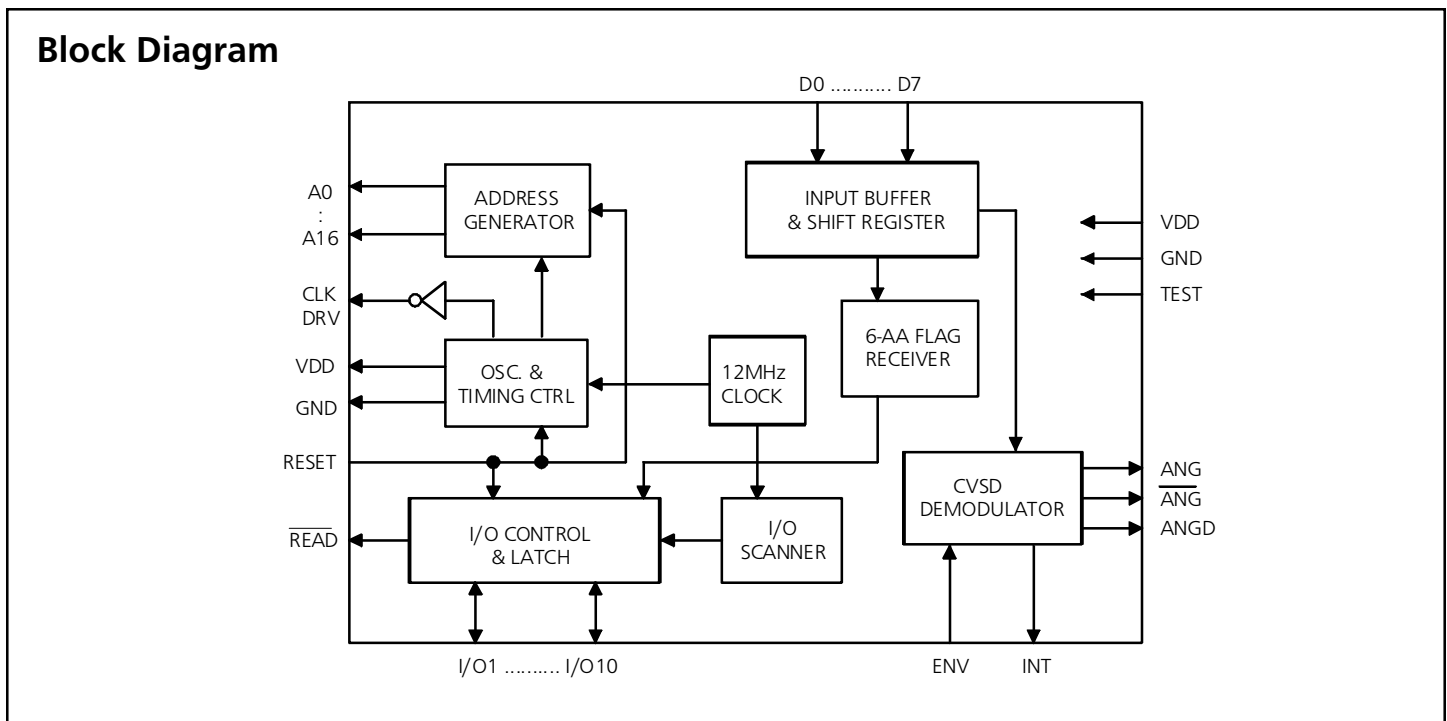

# APPLICATION NOTES

## 1. VP-1410AF Missing A16

Due to packaging constraint, the VP-1410AF does not provide address line A16. Therefore, A16 must be generated externally by adding a binary counter, as explained below.

## 2. Memory Address Expansion

The VP-1410A's internal 17-bit address counter covers memory space up to 128K x 8, or 1M bits. It can be easily expanded by just adding an external binary counter, clocked by the falling edge of address line A16. The first counter output becomes A17, the second output becomes A18 and etc. This is possible since once started, the VP-1410A will continue to play until it reaches the EOM (End Of Message) flag. When the internal address counter reaches the maximum count before the chip sees the EOM flag, the counter simply overflows and restarts from zero again. Therefore the VP-1410A can access an unlimited amount of memory by adding an external address counter.

## 3. EOM (End Of Message) Flag

The EOM flag consists of six consecutive bytes of "AA", or "10101010" in binary format. After a trigger signal is received, the VP-1410A uses the internal 12MHz system clock to scan through memory space and finds the correct message by counting the number of EOM flags. For example, to find the 5th message, it must scan through each and every memory location until it finds 4 EOM flags. The first byte following the 4th EOM flag is the first byte of the 5th message.

## 4. Creating Master EPROM File on the VP-880 System

Follow these steps to create the master EPROM file:

1. Digitize, edit and save each message in a separate file.
2. Use VP-880's function "H" to combine all the messages together. The VP-880 program will automatically search and eliminate any EOM flag within each message, which is naturally formed during digitization. It will then put a EOM flag at the end of each message and combine them into one or several master files.

# CIRCUIT DESIGN EXAMPLES

## 1. 10-Message Playback, 8M EPROM

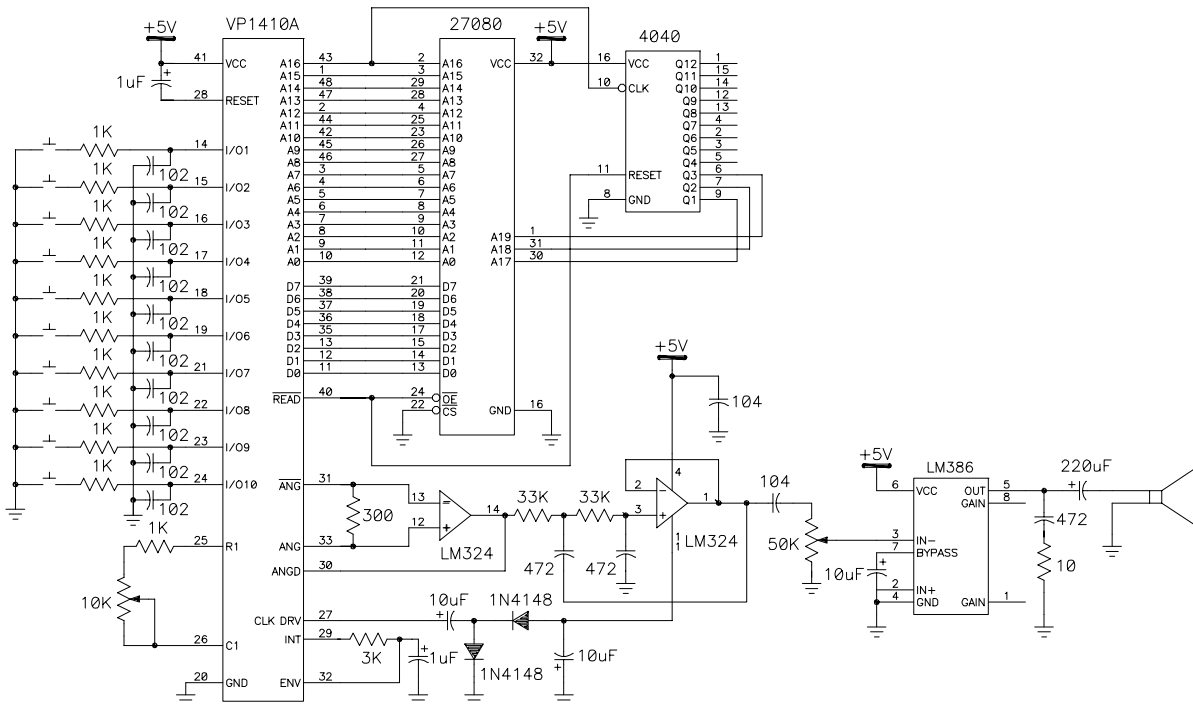

# PACKAGING INFORMATION

48L 10\*10\*2.0mm PQFP (Footprint : 5.0mm)

