

1 WATT UNREGULATED

DC/DC CONVERTERS V-PAC AND S-PAC SERIES

FEATURES

- Ultra-compact SIP and DIP packages
- Designed to meet FCC Sec 15, Sub Part J, A&B
- PC mountable
- Short circuit protected, self recovering
- Input/Output isolated
- Single, dual and combinable outputs
- No derating to 71°C
- High reliability (MTBF > 300,000 hours), demonstrated
- 100 KHZ switching frequency
- 100% burned-in and triple tested
- 3 year warranty

GENERAL DESCRIPTION

This series of 1 watt unregulated DC/DC converters operates from an input of 5VDC or 12VDC and makes available at board level, a wide range of output voltages. These voltages are isolated from the input voltage and some dual outputs are isolated from one another. The converters are encapsulated and operate without derating or heatsinking over their full specified temperature range. Solid tantalum capacitors are used for enhanced reliability. They are specifically designed for RS-232 line driver/receiver, OP-AMP, EPROM, EEPROM and negative voltage biasing applications.

GENERAL ELECTRICAL SPECIFICATIONS

(Specifications at Nominal Input and 25°C)

PARAMETER	LIMIT	CONDITIONS
Input Voltage Range	4.75 - 5.25VDC 11.4 - 12.6VDC	5V Input Devices 12V Input Devices
Input Filter	Filter Cap	See Filtering Options
Input/Output Isolation	10 ³ megohms (Min.) 40 pf (Max.) 500 VDC (Min.)	All Device Types
Output Accuracy	± 10%	Nom. Line and Full Load
Load Regulation	See Graph	
Line Regulation	1%/1% Vin	Typical
Output Voltage Temperature Coefficient	0.05%/°C	Typical
Output Noise/Ripple	300mV, P-P (Max.)	20HZ-20MHZ Bandwidth
Short Circuit Protection	Power Limited	All Units
Duration	Continuous	
Switching Frequency	100 KHZ	Typical
Operating Temperature	-25°C to +71°C	271°C
Derating	None	To 71°C
Storage Temperature	-55°C to +125°C	

SELECTION GUIDE STANDARD PRODUCTS

DEVICE TYPE	INPUT VOLTAGE VDC	INPUT CURRENT A (MAX)	OUTPUT VOLTAGE VDC	OUTPUT CURRENT ma	PACKAGE
SP5	5	.400	+ or - 5	200	SA
VP5	5	.400	+ or - 5	200	VA
SP10	5	.400	+ or - 10	100	SA
VP10	5	.400	+ or - 10	100	VA
SP12/12	5	.400	Dual 12*	±40	SD
VP12/12	5	.400	Dual 12*	±40	VD
SP15/15	5	.400	Dual 15*	±33	SD
VP15/15	5	.400	Dual 15*	±33	VD
SA10.5-10.5	5	.400	±10.5	±40	SC
VA10.5-10.5	5	.400	±10.5	±40	VC
SA12-12	5	.400	±12	±40	SC
VA12-12	5	.400	±12	±40	VC
SA15-15	5	.400	±15	±33	SC
VA15-15	5	.400	±15	±33	VC
S12P5	12	.150	+ or - 5	200	SA
V12P5	12	.150	+ or - 5	200	VA
S12A12-12	12	.200	±12	±40	SC
V12A12-12	12	.200	±12	±40	VC
S12A15-15	12	.200	±15	±33	SC
V12A15-15	12	.200	±15	±33	VC
V24A12-12	24	.200	±12	±40	VC

*Dual isolated (50VDC) output channels.

MECHANICAL DIMENSIONS AND PIN CONNECTIONS

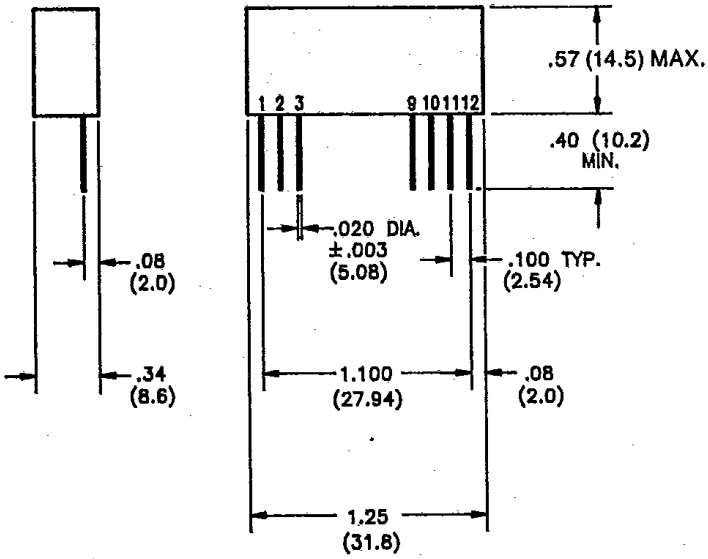

SA	SC	SD
1 +INPUT	1 +INPUT	1 +INPUT
2 NC	2 -OUTPUT 2	2 -OUTPUT 2
3 NC	3 +OUTPUT 2	3 +OUTPUT 2
9 NC	9 NC	9 NC
10 -OUTPUT	10 -OUTPUT 1	10 -OUTPUT 1
11 +OUTPUT	11 +OUTPUT 1	11 +OUTPUT 1
12 -INPUT	12 -INPUT	12 -INPUT

(PIN 3 AND PIN 10 STRAPPED INTERNALLY)

Note: All dimensions in parentheses are mm.
Tolerances unless otherwise specified: .XX ± .03
.XXX ± .010

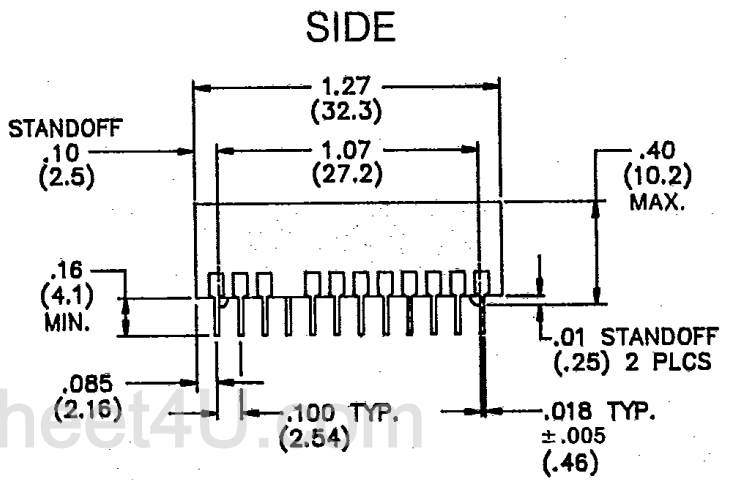
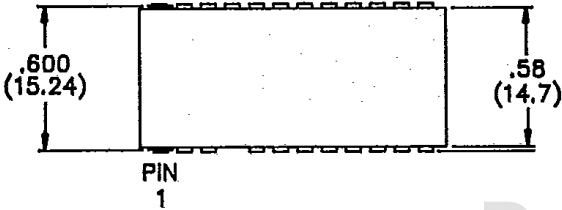

www.DataSheet4U.com

TOP VIEW VA

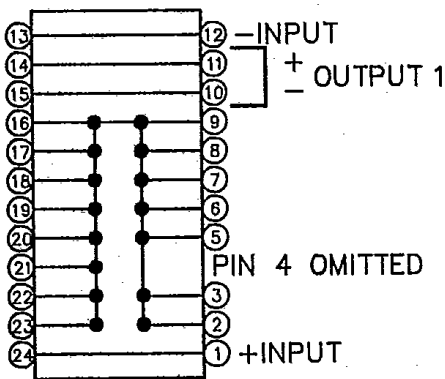

TOP VIEW VC

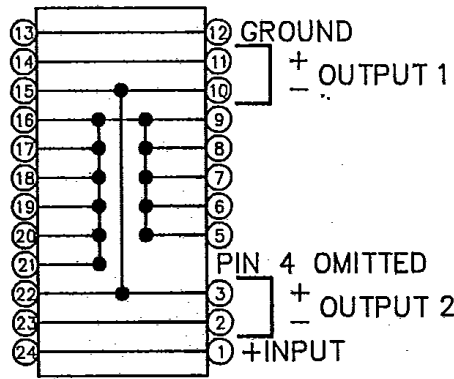

TOP VIEW VD

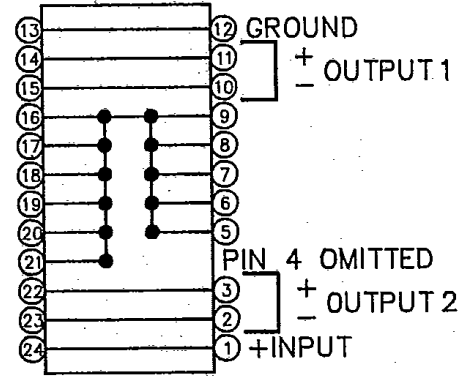

PERFORMANCE DATA

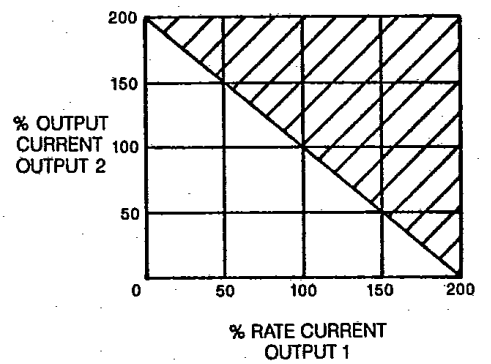
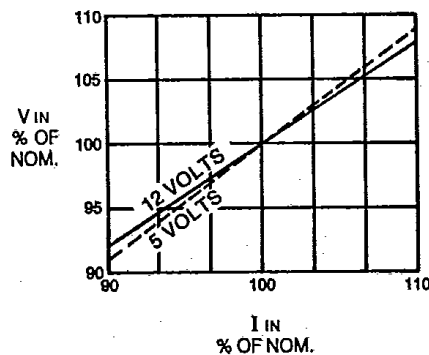
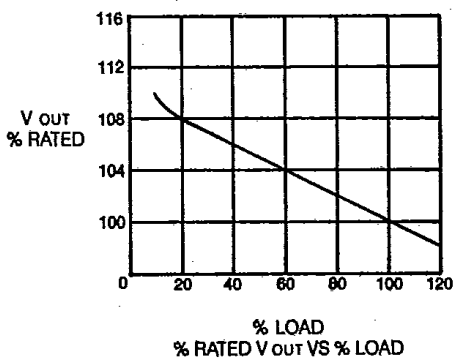

OUTPUT CONFIGURATION OPTIONS

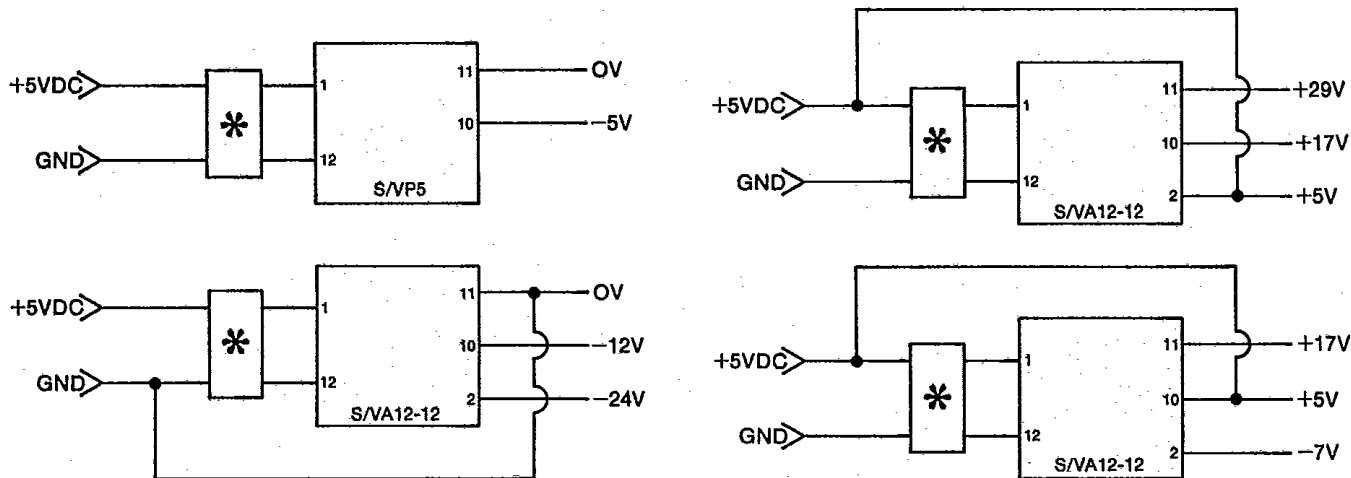

Standard isolated outputs: 5, 10, ± 12 , ± 10.5 , ± 15 VDC

Combined isolated outputs: 21, 24, 30VDC

Combined non-isolated outputs: -3, -7, -12, -15, -24, -30, +17, +20, +26, +29, +35, +36, +42VDC

- Achieving these voltages is dependent on model-type selected and configuration used. Please contact factory for assistance in selection.
- Total load is 1 watt. This load may be split unequally between the two outputs.

TEST CIRCUIT SCHEMATIC

- When measuring output noise use most direct possible connections to ensure correct readings.
- All noise measurements between 20HZ to 20MHZ BW.
- R(LOAD) Selected for maximum rated output current.

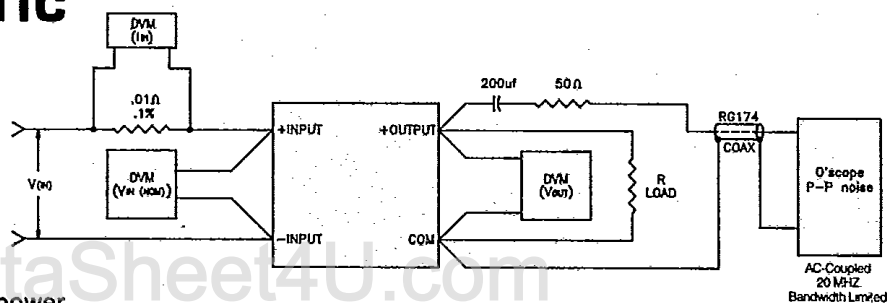

Caution: (1) Do not insert or remove device with power applied. (2) Care must be taken to observe input polarity.

TYPICAL APPLICATION

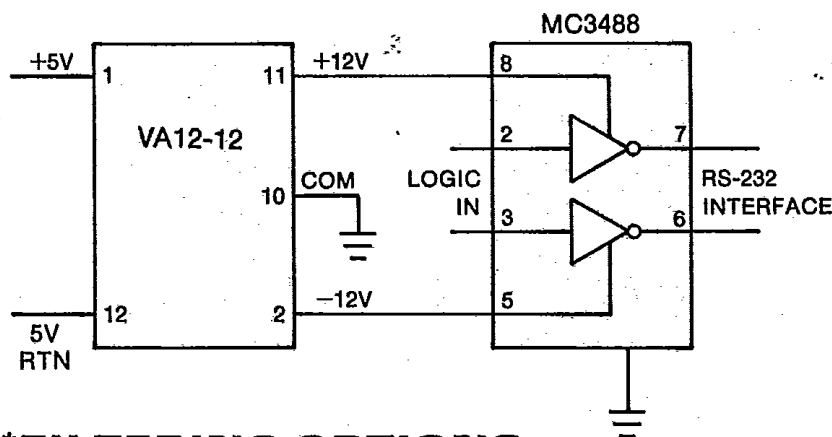

*FILTERING OPTIONS

If the reflected ripple from a V-PAC or S-PAC series device requires reduction, this filter option may be connected externally. A recommended filter configuration with various component values is represented here:

		C1*, C2*	
Z		15 μ F, 20V	39 μ F, 10V
3 μ H	-60db	-70db	
1 Ω	-40db	-50db	

*Low ESR Tantalum Capacitor

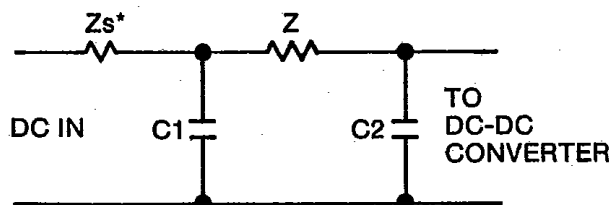

*Zs is Source Impedance