

**Dual Adjustable Positive Voltage Regulators
Radiation Tolerant**

www.aeroflex.com/voltreg

September 9, 2011



FEATURES

- ❑ Manufactured using  Linear Technology Corporation® Space Qualified RH117 die
- ❑ Radiation performance
 - Total dose: 100 krads(Si), Dose rate = 50 - 300 rads(Si)/s
 - ELDRS: 50 krads(Si), Dose rate ≤ 10 mrads(Si)/s
- ❑ Thermal shutdown
- ❑ Output voltage adjustable: 1.25V to 37V
- ❑ 3-Terminal
- ❑ Output current: 1.5A
- ❑ Voltage reference: 1.25V
- ❑ Load regulation: 1.9% max
- ❑ Line regulation: 0.06%/V max
- ❑ Ripple rejection: >66dB
- ❑ Packaging – Hermetic metal
 - Thru-hole or Surface mount
 - 6 Leads, .655"L x .415"W x .200"Ht
 - Power package
 - Weight - 5 gm max
- ❑ Designed for aerospace and high reliability space applications
- ❑ Aeroflex Plainview’s Radiation Hardness Assurance Plan is DLA Certified to MIL-PRF-38534, Appendix G.

DESCRIPTION

The Aeroflex Plainview VRG8607/08 consists of two positive (RH117) voltage regulators each capable of supplying in excess of 1.5Amps over the output voltage range as defined under recommended operating conditions. Each regulator is exceptionally easy to set-up, requiring only 2 external resistors to set the output voltage. The module design has been optimized for excellent regulation and low thermal transients. There is full electrical isolation between the regulators and each regulator to the package.

Further, the VRG8607/08 features internal current limiting, thermal shutdown and safe-area compensation, making them virtually blowout-proof against overloads. The VRG8607/08 serves a wide variety of applications including local on-card regulation, programmable output voltage regulation or precision current regulation.

The VRG8607/08 has been specifically designed to meet exposure to radiation environments. The VRG8607 is configured for a Thru-Hole 6 lead metal power package and the VRG8608 is configured for a Surface Mount 6 lead metal power package. It is guaranteed operational from -55°C to +125°C. Available screened to MIL-STD-883, the VRG8607/08 is ideal for demanding military and space applications.

For detailed performance characteristic curves, applications information and typical applications see the latest  Linear Technology Corporation® data sheets for their RH/LT117, which is available on-line at www.linear.com.

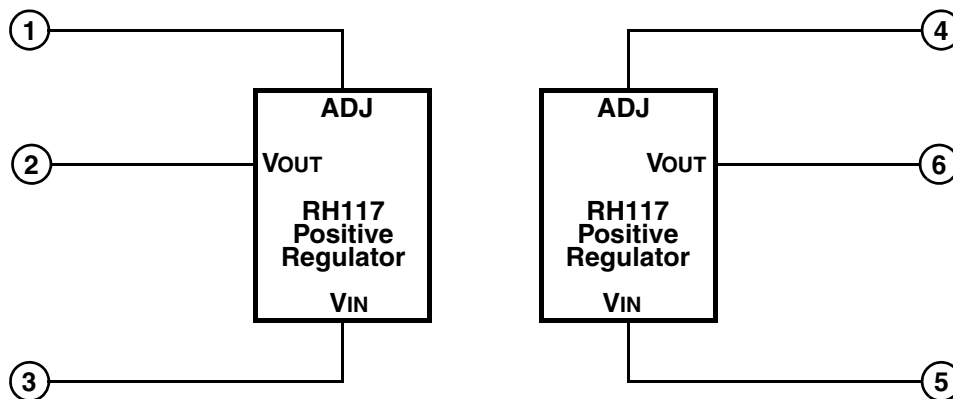

FIGURE 1 – BLOCK DIAGRAM / SCHEMATIC

ABSOLUTE MAXIMUM RATINGS

PARAMETER	RANGE	UNITS
Operating (Junction) Temperature Range	-55 to +150	°C
Lead Temperature (soldering, 10 sec)	300	°C
Storage Temperature Range	-65 to +150	°C
Input-Output Voltage Differential	40 (Pos)	V
Thermal Resistance (Junction to case Θ_{JC}) each Regulator	5	°C/W
ESD Rating	1,999 ^{1/}	KV

^{1/} Meets ESD testing per MIL-STD-883, method 3015, Class 1C.

NOTICE: Stresses above those listed under "Absolute Maximums Rating" may cause permanent damage to the device. These are stress rating only; functional operation beyond the "Operation Conditions" is not recommended and extended exposure beyond the "Operation Conditions" may effect device reliability.

RECOMMENDED OPERATING CONDITIONS

PARAMETER	RANGE	UNITS
Output Voltage Range	1.3 to 37	VDC
Case Operating Temperature Range	-55 to +125	°C

ELECTRICAL PERFORMANCE CHARACTERISTICS ^{1/}

PARAMETER	SYM	CONDITIONS (P ≤ P _{MAX})	MIN	MAX	UNITS
Reference Voltage ^{4/}	V _{REF}	3V ≤ (V _{IN} - V _{OUT}) ≤ V _{DIFF} MAX, 10mA ≤ I _{OUT} ≤ I _{MAX}	1.200	1.300	V
Line Regulation ^{2/ 4/}	$\frac{\Delta V_{OUT}}{\Delta V_{IN}}$	3V ≤ (V _{IN} - V _{OUT}) ≤ V _{DIFF} MAX, I _{OUT} = 10mA	-	0.03	%/V
Load Regulation ^{2/ 4/}	$\frac{\Delta V_{OUT}}{\Delta I_{OUT}}$	10mA ≤ I _{OUT} ≤ I _{MAX} , V _{OUT} ≤ 5V 10mA ≤ I _{OUT} ≤ I _{MAX} , V _{OUT} ≥ 5V	- -	60 1.2	mV %
Thermal Regulation		I _{OUT} = 1.5A, (V _{IN} - V _{OUT}) = 13.3V, 20ms Pulse, 20W, T _C = +25°C	-	0.07	%/W
Ripple Rejection Ratio		V _{OUT} = 10V, f = 120Hz, C _{ADJ} = 10μF	66	-	dB
Adjustment Pin Current ^{4/}	I _{ADJ}	I _{OUT} = 10mA, 3V ≤ (V _{IN} - V _{OUT}) ≤ 40V	-	100	μA
Adjustment Pin Current Change ^{4/}	ΔI _{ADJ}	10mA ≤ I _{OUT} ≤ I _{MAX} 3.0V ≤ (V _{IN} - V _{OUT}) ≤ 40V	-	5	μA
Minimum Load Current ^{3/ 4/}	I _{MIN}	(V _{IN} - V _{OUT}) = 40V	-	5	mA
Current Limit ^{4/ 5/}	I _{MAX}	(V _{IN} - V _{OUT}) ≤ 15V	1.5	-	A
		(V _{IN} - V _{OUT}) = 40V, T _C = +25°C	0.30	-	
Long Term Stability ^{3/}	$\frac{\Delta V_{OUT}}{\Delta TIME}$	T _C = +125°C	-	1	%
Thermal Resistance, each Regulator (Junction to Case) ^{3/}	Θ _{JC}		-	5	°C/W

Notes:

^{1/} Unless otherwise specified, these specifications apply for (V_{in} - V_{out}) = 5V, I_{out} = 0.5A and -55°C < T_c < +125°C.

^{2/} Regulation is measured at a constant junction temperature, using pulse testing with a low duty cycle. Changes in output voltage due to heating effects are covered under the specification for thermal regulation. Measurements taken at the output lead must be adjusted for lead resistance.

^{3/} Not tested. Shall be guaranteed to the specified limits.

^{4/} Specification derated to reflect High Dose Rate (1019 condition A) to 100 krad(Si) and Low Dose Rate (1019 condition D) to 50 krad(Si), @ +25°C.

^{5/} Pulsed @ < 10% duty cycle @ +25°C.

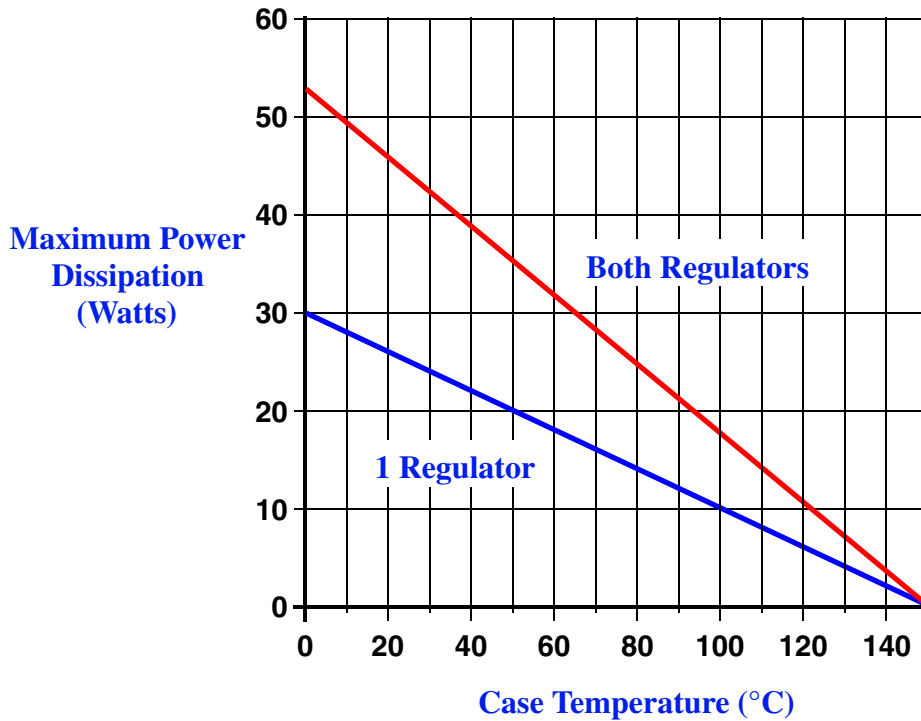
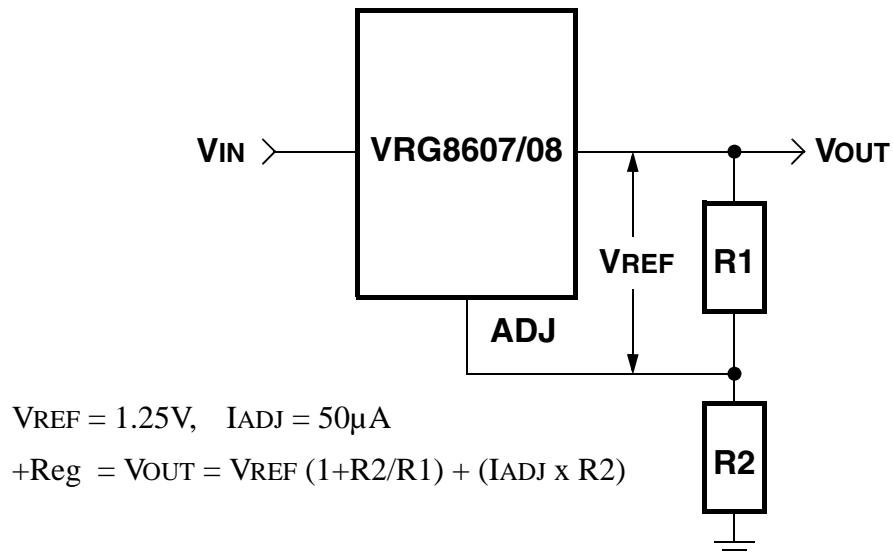

FIGURE 2 – MAXIMUM POWER vs CASE TEMPERATURE

The maximum Power dissipation is limited by the thermal shutdown function of each regulator chip in the VRG8607/08. The graph above represents the achievable power before the chip shuts down. The first line in the graph represents the maximum power dissipation of the VRG8607/08 with one regulator on (the other off) and the other line represents both regulators on dissipating equal power. If both regulators are on and one regulator is dissipating more power than the other, the maximum power dissipation of the VRG8607/08 will fall between the two lines. This graph is based on the maximum junction temperature of 150°C and a thermal resistance (Θ_{JC}) of 5°C/W.



Adjustable Regulator

FIGURE 3 – TYPICAL APPLICATIONS

TABLE I – PIN NUMBERS vs FUNCTION

PIN	FUNCTION
1	POS_ADJ_1
2	POS_VOUT_1
3	POS_VIN_1
4	POS_ADJ_2
5	POS_VIN_2
6	POS_VOUT_2

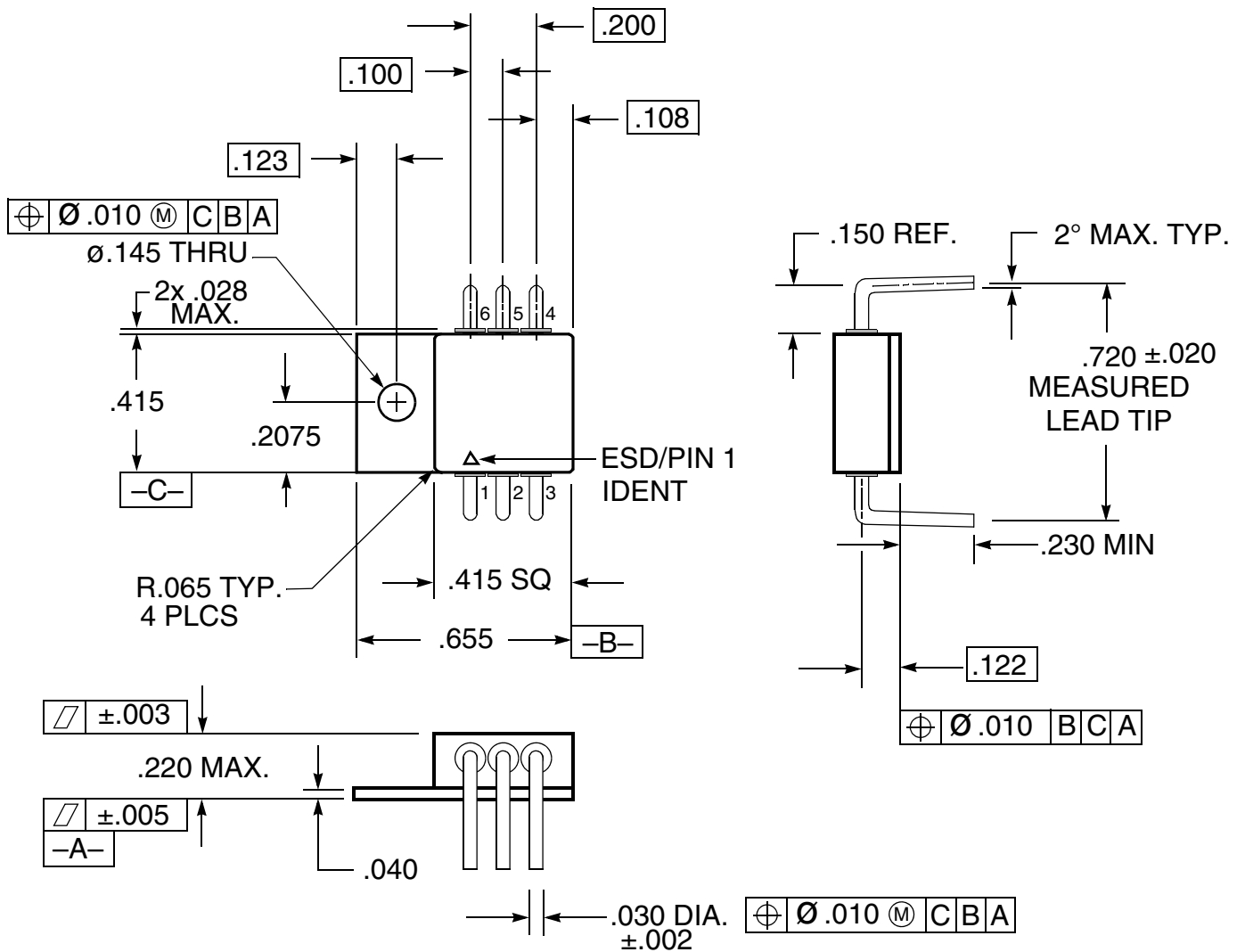

- Notes:
1. Dimension Tolerance: $\pm .005$ inches
 2. Package contains BeO substrate
 3. Case electrically isolated

FIGURE 4 – PACKAGE OUTLINE — THRU-HOLE POWER PACKAGE

TABLE II – PIN NUMBERS vs FUNCTION

PIN	FUNCTION
1	POS_ADJ_1
2	POS_VOUT_1
3	POS_VIN_1
4	POS_ADJ_2
5	POS_VIN_2
6	POS_VOUT_2

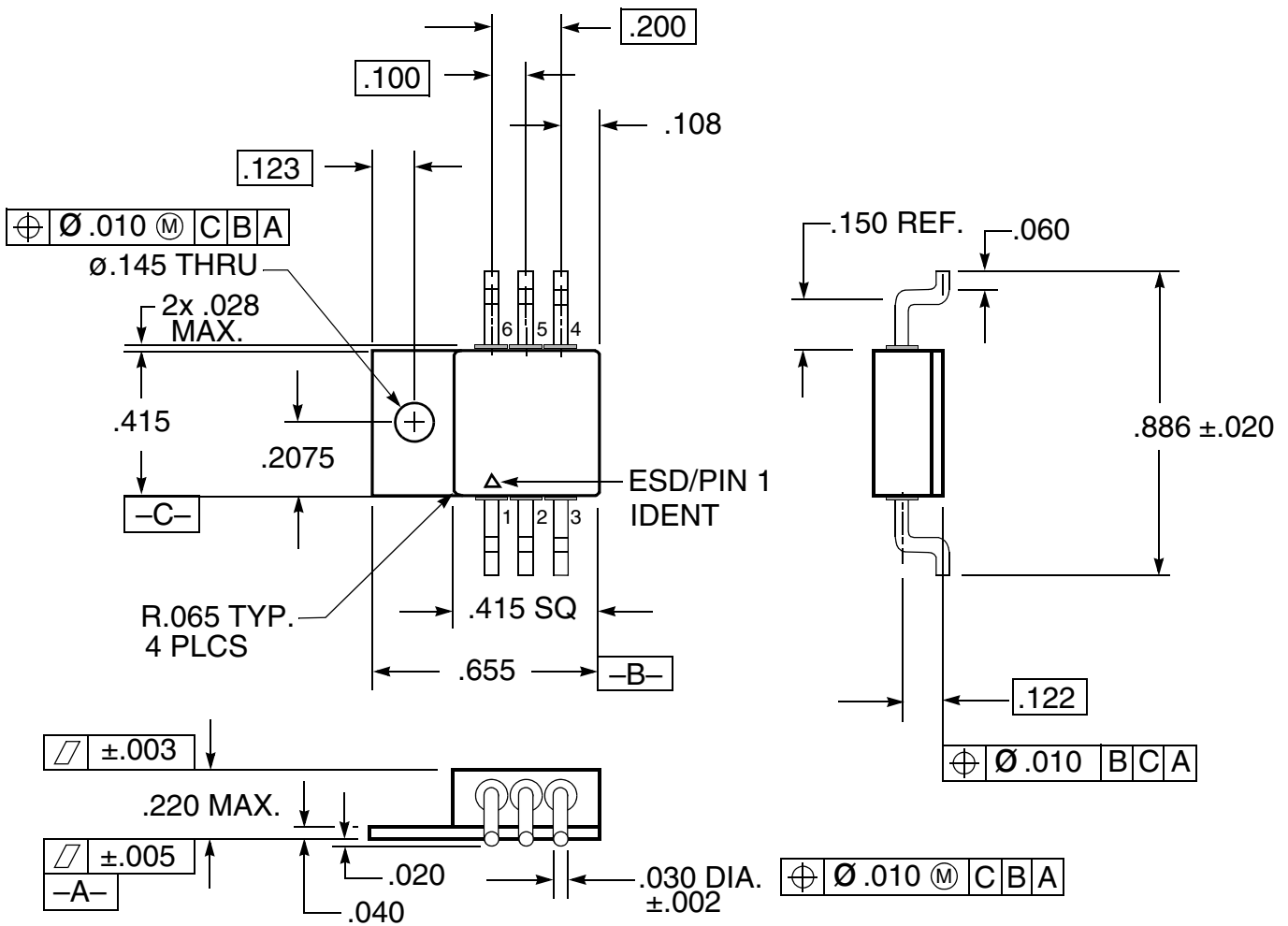

Notes:

1. Dimension Tolerance: $\pm .005$ inches
2. Package contains BeO substrate
3. Case electrically isolated

FIGURE 5 – PACKAGE OUTLINE — SURFACE MOUNT POWER PACKAGE

ORDERING INFORMATION

MODEL	DLA SMD #	SCREENING	PACKAGE
VRG8607-7	-	Commercial Flow, +25°C testing only	6 Lead Thru-Hole Power Pkg
VRG8607-S	-	Military Temperature, -55°C to +125°C Screened in accordance with the individual Test Methods of MIL-STD-883 for Space Applications	
VRG8607-201-1S	5962-0521903KXC	In accordance with DLA SMD	
VRG8607-201-2S	5962-0521903KXA		
VRG8607-901-1S	5962R0521903KXC	In accordance with DLA Certified RHA Program Plan to RHA level "R", 100 krad(Si)	
VRG8607-901-2S	5962R0521903KXA		
VRG8608-7	-	Commercial Flow, +25°C testing only	6 Lead Surface Mount Power Pkg
VRG8608-S	-	Military Temperature, -55°C to +125°C Screened in accordance with the individual Test Methods of MIL-STD-883 for Space Applications	
VRG8608-201-1S	5962-0521903KYC	In accordance with DLA SMD	
VRG8608-201-2S	5962-0521903KYA		
VRG8608-901-1S	5962R0521903KYC	In accordance with DLA Certified RHA Program Plan to RHA level "R", 100 krad(Si)	
VRG8608-901-2S	5962R0521903KYA		

EXPORT CONTROL:

This product is controlled for export under the International Traffic in Arms Regulations (ITAR). A license from the U.S. Department of State is required prior to the export of this product from the United States.

EXPORT WARNING:

Aeroflex's military and space products are controlled for export under the International Traffic in Arms Regulations (ITAR) and may not be sold or proposed or offered for sale to certain countries. (See ITAR 126.1 for complete information.)

PLAINVIEW, NEW YORK

Toll Free: 800-THE-1553
Fax: 516-694-6715

INTERNATIONAL

Tel: 805-778-9229
Fax: 805-778-1980

NORTHEAST

Tel: 603-888-3975
Fax: 603-888-4585

SE AND MID-ATLANTIC

Tel: 321-951-4164
Fax: 321-951-4254

WEST COAST

Tel: 949-362-2260
Fax: 949-362-2266

CENTRAL

Tel: 719-594-8017
Fax: 719-594-8468

www.aeroflex.com info-ams@aeroflex.com

Aeroflex Microelectronic Solutions reserves the right to change at any time without notice the specifications, design, function, or form of its products described herein. All parameters must be validated for each customer's application by engineering. No liability is assumed as a result of use of this product. No patent licenses are implied.



and the Linear Technology logo are registered trademarks and RH117 are a copyright of Linear Technology Corporation.



Our passion for performance is defined by three attributes represented by these three icons: solution-minded, performance-driven and customer-focused