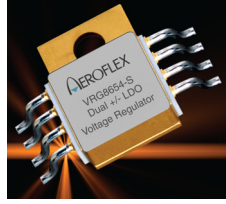


# VRG8653/VRG8654


## Dual Voltage Regulator, 3.0 Amp, Positive & Negative Low Dropout (LDO), Adjustable Radiation Tolerant

www.aeroflex.com/voltreg

April 10, 2014



### FEATURES

- ❑ Manufactured using  Space Qualified RH1084 and RH1185 die
- ❑ Radiation performance
  - Total dose  $\geq 100$  krad (Si)
- ❑ Two-Independent voltage regulators
- ❑ Thermal shutdown
- ❑ Adjustable Output Voltages
- ❑ **Positive** regulator features (RH1084)
  - Output voltage adjustable: 1.25V to 23V
  - Dropout voltage: 1.80V at 3.0A
  - 3-Terminal
  - Output current: 3.0A
  - Voltage reference: 1.25V +2%, -3.2%
  - Load regulation: 0.35% max
  - Line regulation: 0.25% max
  - Ripple rejection: >60dB
- ❑ **Negative** regulator features (RH1185)
  - Output voltage adjustable: -2.37 to -25V
  - Dropout voltage: 1.05V at 3.0A
  - 5-Terminal
  - Output current: 3.0A
  - Voltage reference: -2.370V  $\pm 3.5\%$
  - Load regulation: 0.8% max
  - Line regulation: 0.02% max
  - Ripple rejection: >60dB
- ❑ **Packaging** – Hermetic metal
  - Thru-hole or Surface mount
  - 8 Leads, .755"L x .415"W x .200"Ht
  - Power package
  - Weight - 6 gm max
- ❑ Designed for aerospace and high reliability space applications
- ❑ **Aeroflex Plainview's Radiation Hardness Assurance Plan is DLA Certified to MIL-PRF-38534, Appendix G.**

### DESCRIPTION

The Aeroflex Plainview VRG8653/54 consists of one Positive Adjustable (RH1084) and one Negative Adjustable (RH1185) LDO voltage regulator, both capable of supplying 3.0A over the output voltage range as defined under recommended operating conditions. The VRG8653/54 offers excellent line and load regulation specifications and ripple rejection. There is full electrical isolation between the regulators and each regulator to the package.

The VRG8653/54 serves a wide variety of applications including SCSI-2 Active Terminator, High Efficiency Linear Regulators, Post Regulators for Switching Supplies, Constant Current Regulators, Battery Chargers and Microprocessor Supply.

The VRG8653/54 has been specifically designed to meet exposure to radiation environments and is configured for a Thru-Hole 8 lead metal power package and the VRG8654 is configured for a Surface Mount 8 lead metal power package. It is guaranteed operational from -55°C to +125°C. Available screened in accordance with MIL-PRF-38534, the VRG8653/54 is ideal for demanding military and space applications.

Dropout ( $V_{IN} - V_{OUT}$ ) decreases at lower load currents for both regulators.

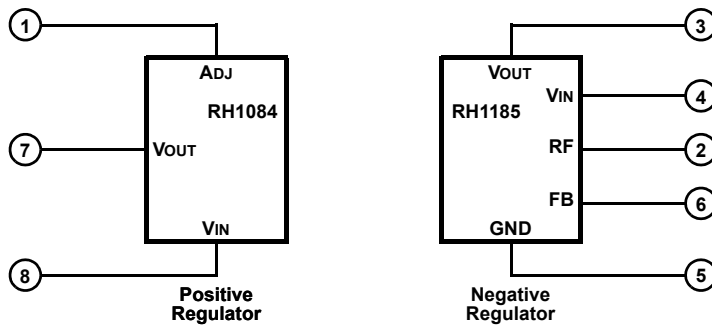


FIGURE 1 – BLOCK DIAGRAM / SCHEMATIC

## ABSOLUTE MAXIMUM RATINGS

Parameter	Rating		Units
	RH1084	RH1185	
Input Voltage	+25	-35	VDC
Lead temperature (soldering 10 Sec)	300		°C
Input Output Differential	25	30	VDC
Load Current, maximum	+6.0	-4.5	A
Feedback & Reference Voltage	-	-7	VDC
Output Voltage	+25	-30	VDC
ESD (MIL-STD-883, M3015, Class 2)	2000 to 3999		V
Operating Junction Temperature Range	-55 to +150		°C
Storage Temperature Range	-65 to +150		°C
Thermal Resistance (Junction to Case) $\Theta_{JC}$	5		°C/W

NOTICE: Stresses above those listed under "Absolute Maximum Ratings" may cause permanent damage to the device. These are stress rating only; functional operation beyond the "Operation Conditions" is not recommended and extended exposure beyond the "Operation Conditions" may effect device reliability.

## RECOMMENDED OPERATING CONDITIONS

Parameter	Range		Units
	RH1084	RH1185	
Output Voltage Range	1.25 to 23	-2.37 to -25	VDC
Input Output Differential	1.8 to 24	1.05 to 29	VDC
Case Operating Temperature Range	-55 to +125		°C

## ELECTRICAL PERFORMANCE CHARACTERISTICS

UNLESS OTHERWISE SPECIFIED:  $-55^{\circ}\text{C} \leq T_C \leq +125^{\circ}\text{C}$

Parameter	Symbol	Conditions ( $P \leq P_{MAX}$ )	Min	Max	Units
<b>RH1084 Positive LDO section only 1/</b>					
Reference Voltage 2/, 3/	$V_{REF}$	$1.5V \leq (V_{IN} - V_{OUT}) \leq 15V$ , $10mA \leq I_{OUT} \leq 3.0A$	1.210	1.275	V
Line Regulation 2/, 3/	$\frac{\Delta V_{OUT}}{\Delta V_{IN}}$	$I_{LOAD} = 10mA$ , $1.5V \leq (V_{IN} - V_{OUT}) \leq 15V$	-	0.25	%
Load Regulation 2/, 3/	$\frac{\Delta V_{OUT}}{\Delta I_{OUT}}$	$10mA \leq I_{OUT} \leq 3.0A$ , $(V_{IN} - V_{OUT}) = 3V$	-	0.35	%
Dropout Voltage 2/, 4/	$V_{DROP1}$	$\Delta V_{REF} = 1\%$ , $I_{OUT} = 5.0A$	-	1.8	V
Dropout Voltage	$V_{DROP2}$	$\Delta V_{REF} = 1\%$ , $I_{OUT} = 3.0A$	-	1.4	V
Adjust Pin Current 2/	-		-	120	$\mu A$
Adjust Pin Current Change 2/	-	$10 mA \leq I_{OUT} \leq 3.0A$ , $1.5V \leq (V_{IN} - V_{OUT}) \leq 15V$	-	5	$\mu A$
Minimum Load Current 5/	$I_{MIN}$	$(V_{IN} - V_{OUT}) = 25V$	-	10	mA
Current Limit	$I_{CL}$	$(V_{IN} - V_{OUT}) = 5V$	5.25		A
Ripple Rejection 3/	-	$I_{OUT} = 0.5A$ , $(V_{IN} - V_{OUT}) = 3V$ , $f = 120Hz$ , $C_{ADJ} = C_{OUT} = 25\mu F$	60	-	dB
Thermal Regulation	-	30ms pulse, $T_C = +25^{\circ}\text{C}$	-	0.04	%/W

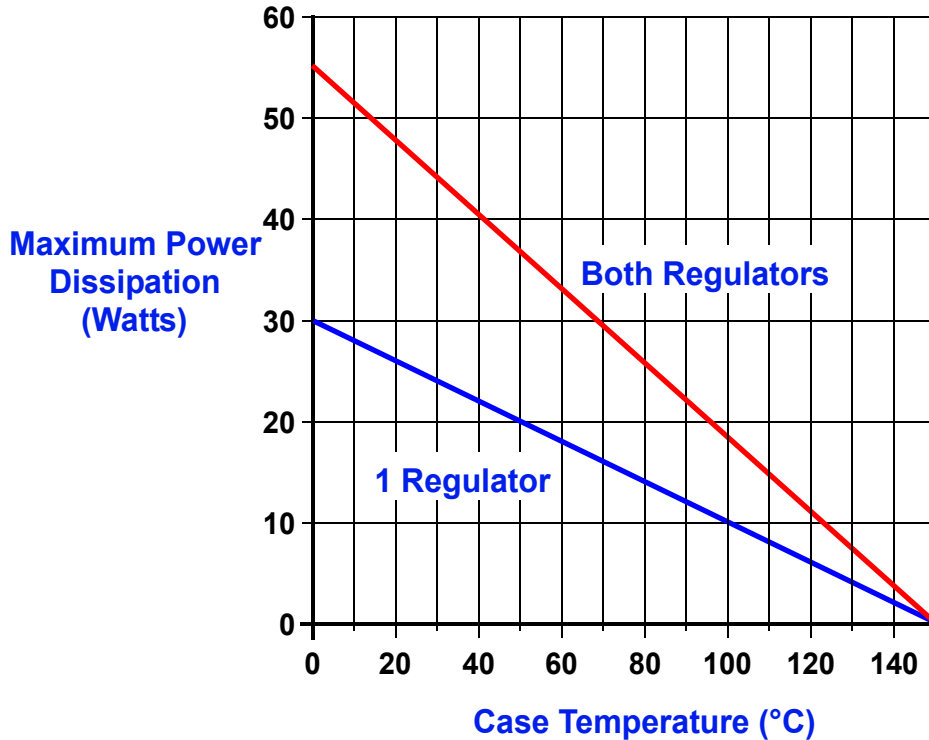
## ELECTRICAL PERFORMANCE CHARACTERISTICS (continued)

UNLESS OTHERWISE SPECIFIED:  $-55^{\circ}\text{C} \leq T_C \leq +125^{\circ}\text{C}$

Parameter	Symbol	Conditions ( $P \leq P_{MAX}$ )	Min	Max	Units
<b>RH1185 Negative LDO section only 9/</b>					
Reference Voltage (At pin 6) 2/	VREF	$1\text{mA} \leq I_{OUT} \leq 3\text{A}$ , $V_{IN} - V_{OUT} = 1.2\text{V to } 28\text{V}$ , $V_{OUT} = -5\text{V}$	-2.29	-2.45	V
Dropout Voltage 2/, 6/	VDROP	$I_{OUT} = 0.5\text{A}$ , $V_{OUT} = -5\text{V}$	-	0.425	V
		$I_{OUT} = 3\text{A}$ , $V_{OUT} = -5\text{V}$	-	1.05	V
Line Regulation 2/, 10/	$\frac{\Delta V_{OUT}}{\Delta V_{IN}}$	$1.0\text{V} \leq V_{IN} - V_{OUT} \leq 20\text{V}$ , $V_{OUT} = -5\text{V}$	-	0.02	%/V
Load Regulation 2/, 10/	$\frac{\Delta V_{OUT}}{\Delta I_{OUT}}$	$5\text{mA} \leq I_{OUT} \leq 3\text{A}$ , $V_{IN} - V_{OUT} = 1.5\text{V to } 10\text{V}$ , $V_{OUT} = -5\text{V}$	-	0.8	%
Minimum Input Voltage 2/, 7/	VIN MIN	$I_{OUT} = 3\text{A}$ , $V_{OUT} = V_{REF}$	-	-4.50	V
Internal Current Limit (See Graph for Guaranteed Curve - See Figure 6) 2/, 13/	ICL	$1.5\text{V} \leq V_{IN} - V_{OUT} \leq 10\text{V}$	3.3	4.55	A
		$V_{IN} - V_{OUT} = 15\text{V}$	2.0	4.5	A
		$V_{IN} - V_{OUT} = 20\text{V}$	1.0	3.1	A
External Current Limit 2/	ILIM	$R_{LIM} = 5\text{K}\Omega$ , $(V_{IN} - V_{OUT}) = 1.5\text{V}$ 12/	2.7	3.7	A
		$R_{LIM} = 15\text{K}\Omega$ , $(V_{IN} - V_{OUT}) = 1.5\text{V}$ 12/	0.9	1.6	A
Quiescent Supply Current 2/, 8/	IQ	$I_{OUT} = 5\text{mA}$ , $V_{OUT} = V_{REF}$ , $-4\text{V} \leq V_{IN} \leq -25\text{V}$	-	3.5	mA
Supply Current Change with Load 2/	IQΔ	$V_{IN} - V_{OUT} = V_{SAT}$ 11/	-	35	mA/A
		$V_{IN} - V_{OUT} \geq 2\text{V}$	-	21	mA/A
Ripple Rejection	-	$I_{OUT} = 0.5\text{A}$ , $V_{IN} - V_{OUT} = 3\text{V}$ , $f = 120\text{Hz}$ ,	60	-	dB

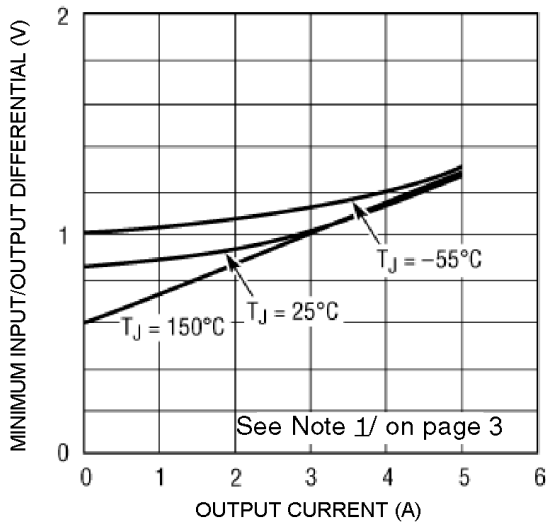
### Notes

- 1/ The manufacturer's output current rating for the RH1084MK positive regulator integrated circuit is 5.0 Amps. For Compliance with the Current Density specification of MIL-STD-883 Rev. C, the electrical performance characteristics are specified at an output current of 3.0 Amps.
- 2/ Specification derated to reflect total dose exposure to 100krads (Si) at +25°C.
- 3/ Line and load regulation are guaranteed up to the maximum power dissipation of 25W. Power dissipation is determined by the input/output differential voltage and the output current. Guaranteed maximum power dissipation will not be available over the full input/output voltage range.
- 4/ Dropout voltage is specified over the full output current range of the device.
- 5/ Not tested. Shall be guaranteed by design, characterization, or correlation to other tested parameters.
- 6/ Dropout voltage is tested by reducing input voltage until the output drops 1% below its nominal value. Tests are done at 0.5A and 3A. The power transistor looks basically like a pure resistance in this range so that minimum differential at any intermediate current can be calculated by interpolation;  $V_{DROPOUT} = 0.25\text{V} + (0.25\Omega \times I_{OUT})$ . For load current less than 0.5A, see Figure 4.
- 7/ "Minimum input voltage" is limited by base emitter voltage drive of the power transistor section, not saturation as measured in Note 6. For output voltages below 4V, "minimum input voltage" specification may limit dropout voltage before transistor saturation limitation.
- 8/ Supply current is measured on the ground pin, and does not include load current, RLIM, or output divider current.
- 9/ The 25W power level is guaranteed for an input-output voltage of 8.3V to 17V. At lower voltages the 3A limit applies, and at higher voltages the internal power limiting may restrict regulator power below 25W.
- 10/ Line and load regulation are measured on a pulse basis with a pulse width of 2ms, to minimize heating. DC regulation will be affected by thermal regulation and temperature coefficient of the reference.
- 11/ VSAT is the maximum specified dropout voltage;  $0.25\text{V} + (0.25\Omega \times I_{OUT})$ .
- 12/ Current limit is programmed with a resistor from REF pin to GND pin.  $R_{LIM} = 15\text{K}\Omega/ILIM$ .
- 13/ Pulsed @ <10% duty cycle @ +25°C

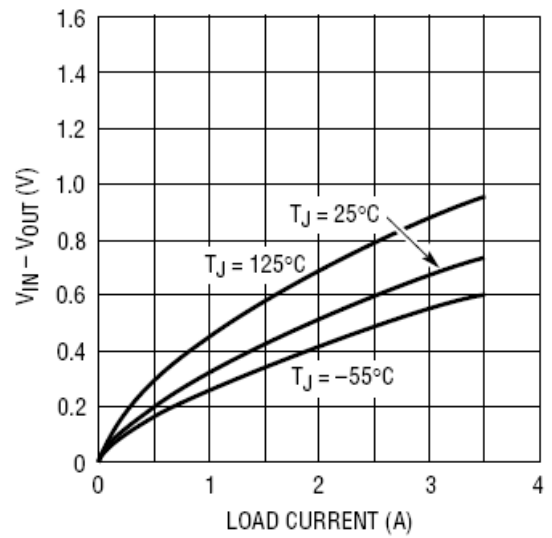


**FIGURE 2 – MAXIMUM POWER vs CASE TEMPERATURE**

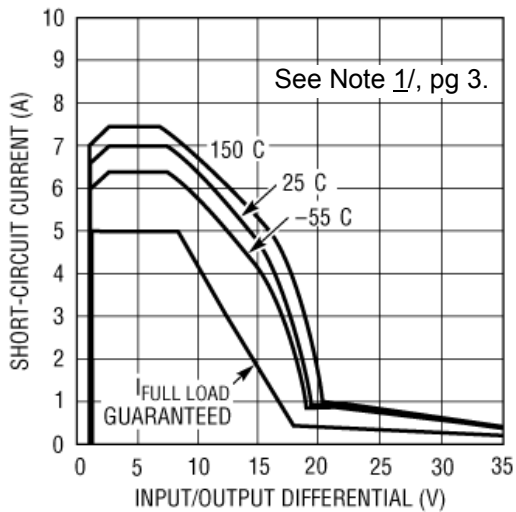
The maximum Power dissipation is limited by the thermal shutdown function of each regulator chip in the VRG8653/54. The graph above represents the achievable power before the chip shuts down. The first line in the graph represents the maximum power dissipation of the VRG8653/54 with one regulator on (the other off) and the other line represents both regulators on dissipating equal power. If both regulators are on and one regulator is dissipating more power than the other, the maximum power dissipation of the VRG8653/54 will fall between the two lines. This graph is based on the maximum junction temperature of 150°C and a thermal resistance ( $\theta_{JC}$ ) of 5°C/W.



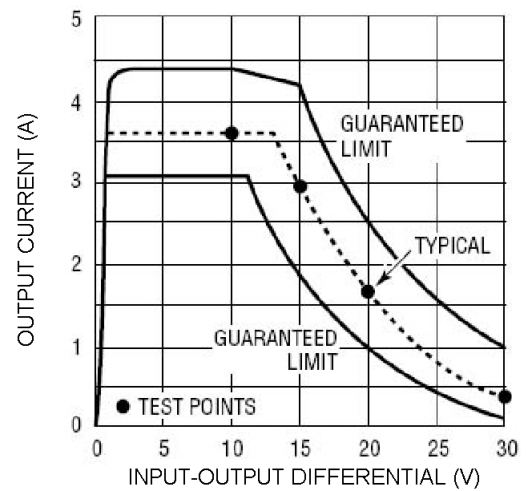
**FIGURE 3 – RH1084 DROPOUT VOLTAGE TYPICAL CURVE**



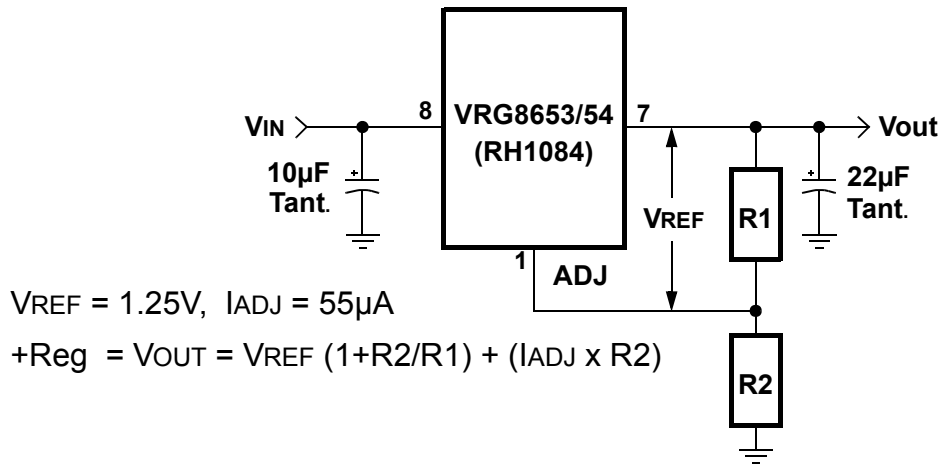
**FIGURE 4 – RH1185 DROPOUT VOLTAGE TYPICAL CURVE**



**FIGURE 5 – RH1084 SHORT CIRCUIT CURRENT**



**FIGURE 6 – RH1185 INTERNAL CURRENT LIMIT**



**FIGURE 7 – BASIC RH1084 POSITIVE ADJUSTABLE REGULATOR APPLICATION**

The RH1185 output voltage is set by two external resistors. Internal reference voltage is trimmed to 2.37V so that a standard 1% 2.37k resistor (R1) can be used to set divider current at 1mA. R2 is then selected from:

$$R2 = \frac{(V_{OUT} - 2.37) R1}{V_{REF}}$$

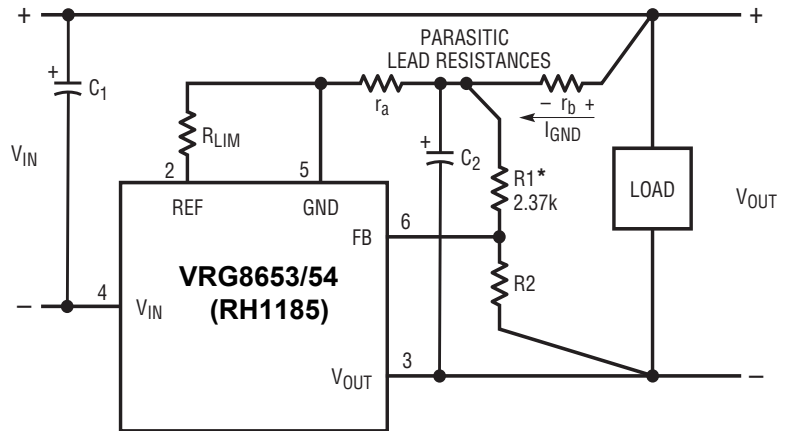
for  $R1 = 2.37k$  and  $V_{REF} = 2.37V$ , this reduces to:

$$R2 = \frac{V_{OUT} - 2.37}{10^{-3}}$$

suggested values of 1% resistors are shown.

$V_{OUT}$	$R2$ WHEN $R1 = 2.37k$
2.5V	130Ω
3.3V	930Ω
5V	2.67k
12V	9.76k
15V	12.7k

**SETTING OUTPUT VOLTAGE**



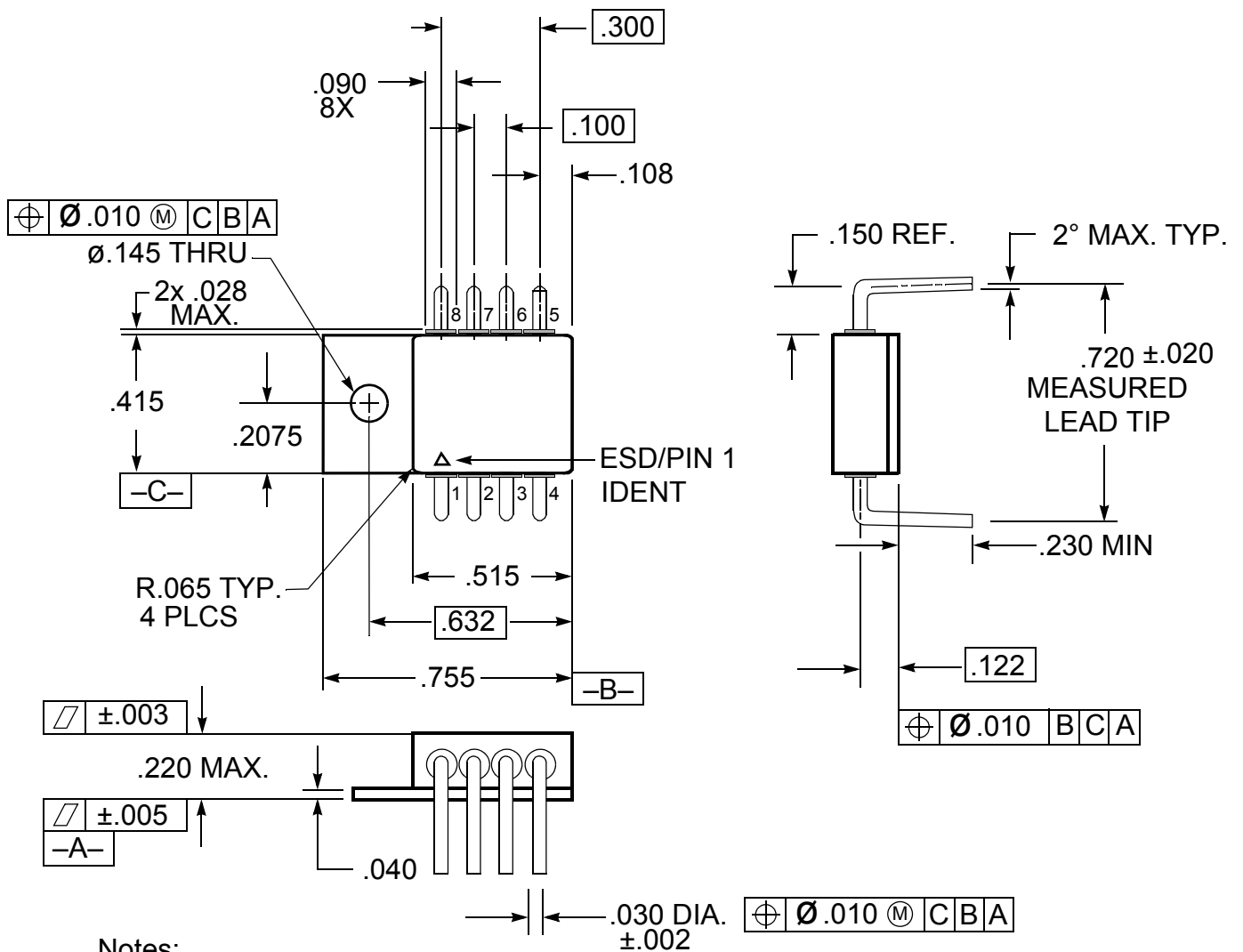
\*R1 SHOULD BE CONNECTED DIRECTLY TO GROUND LEAD, NOT TO THE LOAD, SO THAT  $r_a \approx 0\Omega$ . THIS LIMITS THE OUTPUT VOLTAGE ERROR TO  $(I_{GND})(r_b)$ . ERRORS CREATED BY  $r_a$  ARE MULTIPLIED BY  $(1 + R2/R1)$ . NOTE THAT  $V_{OUT}$  INCREASES WITH INCREASING GROUND PIN CURRENT. R2 SHOULD BE CONNECTED DIRECTLY TO LOAD FOR REMOTE SENSING.  $C1 = C2 \geq 2\mu F$  Tantalum.

**R1 & R2 LOCATION & PROPER CONNECTION OF POSITIVE SENSE LEAD**

**FIGURE 8 – BASIC RH1185 NEGATIVE ADJUSTABLE REGULATOR APPLICATION**

**TABLE I – PIN NUMBERS vs FUNCTION**

PIN	FUNCTION
1	POS_ADJ_1
2	NEG_REF_2
3	NEG_VOUT_2
4	NEG_VIN_2
5	NEG_GND_2
6	NEG_FB_2
7	POS_VOUT_1
8	POS_VIN_1

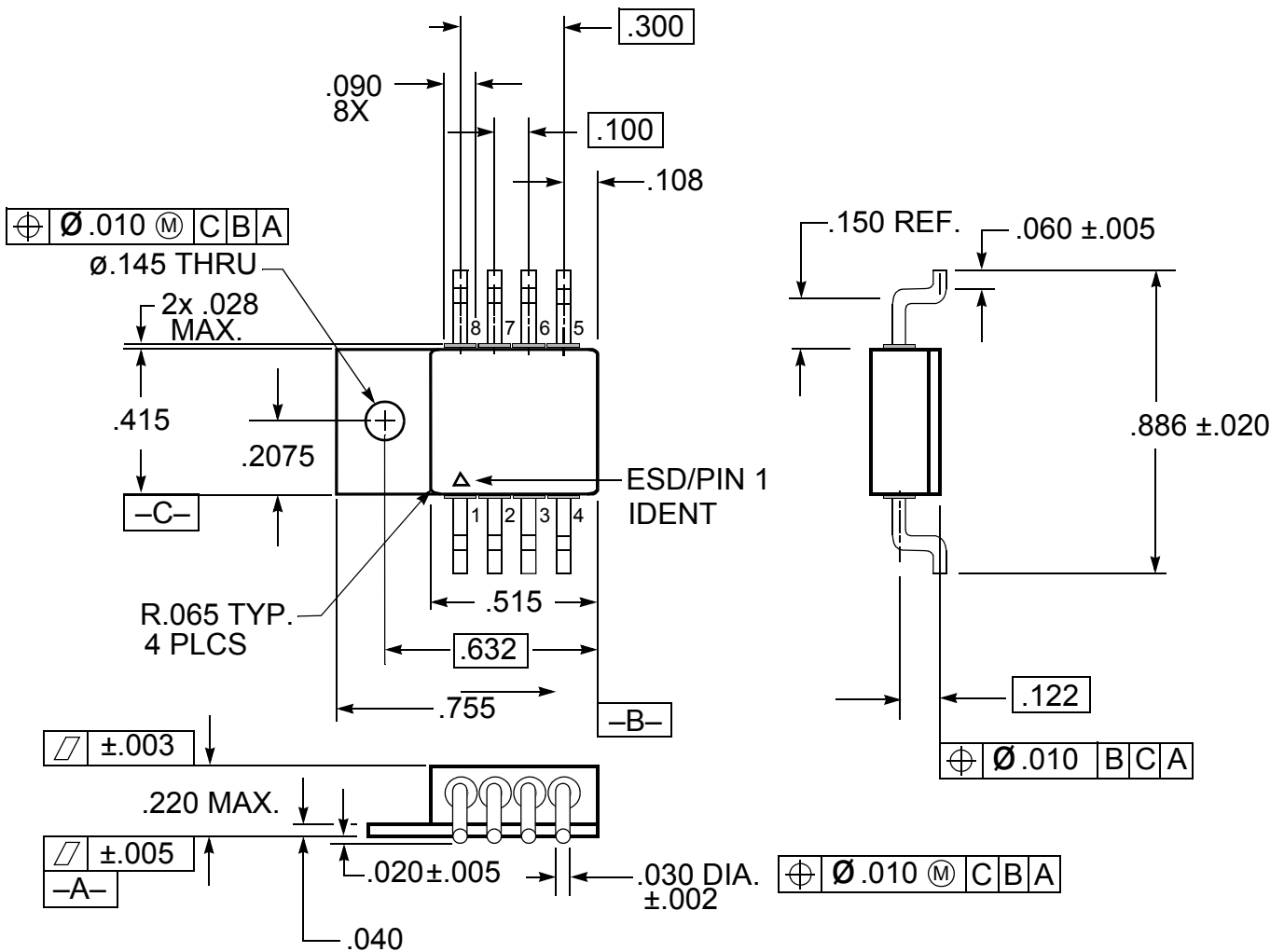


- Notes:
1. Dimension Tolerance:  $\pm .005$  inches
  2. Package contains BeO substrate
  3. Case electrically isolated

**FIGURE 9 – VRG8653 PACKAGE OUTLINE — THRU-HOLE POWER PACKAGE**

**TABLE II – PIN NUMBERS vs FUNCTION**

PIN	FUNCTION
1	POS_ADJ_1
2	NEG_REF_2
3	NEG_VOUT_2
4	NEG_VIN_2
5	NEG_GND_2
6	NEG_FB_2
7	POS_VOUT_1
8	POS_VIN_1



**Notes:**


1. Dimension Tolerance:  $\pm .005$  inches
2. Package contains BeO substrate
3. Case electrically isolated

**FIGURE 10 – VRG8654 PACKAGE OUTLINE — SURFACE MOUNT POWER PACKAGE**



## ORDERING INFORMATION

Model	DLA SMD #	Screening	Package
VRG8653-7	-	Commercial Flow, +25°C testing only	8 Lead Thru-Hole Power Pkg
VRG8653-201-1S	5962-1021301KUC	In accordance with DLA SMD	
VRG8653-201-2S	5962-1021301KUA		
VRG8653-901-1S	5962R1021301KUC	In accordance with DLA Certified RHA Program Plan to RHA Level "R", 100krads(Si)	
VRG8653-901-2S	5962R1021301KUA		
VRG8654-7	-	Commercial Flow, +25°C testing only	8 Lead Surface Mount Power Pkg
VRG8654-201-1S	5962-1021301KZC	In accordance with DLA SMD	
VRG8654-201-2S	5962-1021301KZA		
VRG8654-901-1S	5962R1021301KZC	In accordance with DLA Certified RHA Program Plan to RHA Level "R", 100krads(Si)	
VRG8654-901-2S	5962R1021301KZA		

For detailed performance characteristic curves, applications information and typical applications see the latest  datasheets for their RH1084 & RH1185, which are available on-line at [www.linear.com](http://www.linear.com).

### EXPORT CONTROL:

*This product is controlled for export under the International Traffic in Arms Regulations (ITAR). A license from the U.S. Government is required prior to the export of this product from the United States.*

[www.aeroflex.com/HiRel](http://www.aeroflex.com/HiRel)    [info-ams@aeroflex.com](mailto:info-ams@aeroflex.com)

#### Datasheet Definitions:

<i>Advanced Preliminary Datasheet</i>	<i>Product in Development Shipping Non-Flight Prototypes Shipping QML and Reduced HiRel</i>
---------------------------------------	---



Aeroflex Plainview, Inc. reserves the right to make changes to any products and services described herein at any time without notice. Consult Aeroflex or an authorized sales representative to verify that the information in this data sheet is current before using this product. Aeroflex does not assume any responsibility or liability arising out of the application or use of any product or service described herein, except as expressly agreed to in writing by Aeroflex; nor does the purchase, lease, or use of a product or service from Aeroflex convey a license under any patent rights, copyrights, trademark rights, or any other of the intellectual rights of Aeroflex or of third parties.

Our passion for performance is defined by three attributes.




Solution-Minded



Performance-Driven



Customer-Focused

LT, LTC, , Linear Technology and the Linear logo are registered trademarks and RH1084 & RH1185 is copyright Linear Technology Corporation.