

## Standard Products

# VRG8660

## Adjustable Regulator

## Positive Voltage

## Radiation Tolerant

[www.aeroflex.com/voltreg](http://www.aeroflex.com/voltreg)

April 12, 2012

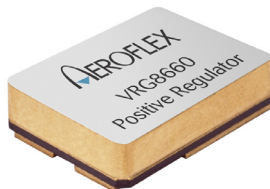

**AEROFLEX**  
A passion for performance.

### FEATURES

- ❑ Manufactured using  Space Qualified RH117 die
- ❑ Radiation performance
  - Total dose:  $\geq 100$  krad(Si), Dose rate = 50 - 300 rads(Si)/s
  - ELDRS:  $\geq 50$  krad(Si), Dose rate = 0.01 rads(Si)/s
- ❑ Thermal shutdown
- ❑ Output voltage adjustable: 1.25V to 37V
- ❑ 3-Terminal
- ❑ Output current: 1.5A
- ❑ Voltage reference: 1.25V  $\pm 4\%$
- ❑ Load regulation: 1.9% max
- ❑ Line regulation: 0.06%/V max
- ❑ Ripple rejection:  $>66$ dB
- ❑ Packaging – Hermetic Ceramic
  - SMD-0.5 Surface mount
  - 3 Pads, .400"L x .296"W x .120"Ht
  - Power package
  - Weight - 2 gm max
- ❑ Designed for aerospace and high reliability space applications
  
- ❑ **Aeroflex Plainview's Radiation Hardness Assurance Plan is DLA Certified to MIL-PRF-38534, Appendix G.**

### DESCRIPTION

The Aeroflex Plainview VRG8660 consists of a Positive Adjustable (RH117) voltage regulator capable of supplying 1.5Amps over the output voltage range as defined under recommended operating conditions. The VRG8660 offers excellent line and load regulation specifications and ripple rejection. The VRG8660 serves a wide variety of applications including High Efficiency Linear Regulators, Post Regulators for Switching Supplies, Constant Current Regulators, Battery Chargers and Microprocessor Supply.

The VRG8660 has been specifically designed to meet exposure to radiation environments and is configured for a SMD-0.5 SMT power package. It is guaranteed operational from  $-55^{\circ}\text{C}$  to  $+125^{\circ}\text{C}$ . Available screened to MIL-STD-883, the VRG8660 is ideal for demanding military and space applications.

Dropout ( $V_{IN} - V_{OUT}$ ) decreases at lower load currents.

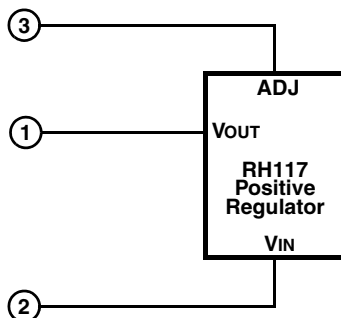

**FIGURE 1 – BLOCK DIAGRAM / SCHEMATIC**

## ABSOLUTE MAXIMUM RATINGS

PARAMETER	RANGE	UNITS
Lead temperature (soldering 10 Sec)DC	300	°C
Input-Output Voltage Differential	40	V <sub>DC</sub>
ESD	1.999 <sup>1/</sup>	KV
Operating Junction Temperature Range	-55 to +150	°C
Storage Temperature Range	-65 to +150	°C

<sup>1/</sup> Meets ESD testing per MIL-STD-883, method 3015, Class 1C.

NOTICE: Stresses above those listed under "Absolute Maximum Ratings" may cause permanent damage to the device. These are stress rating only; functional operation beyond the "Operation Conditions" is not recommended and extended exposure beyond the "Operation Conditions" may effect device reliability.

## RECOMMENDED OPERATING CONDITIONS

PARAMETER	RANGE	UNITS
Output Voltage Range	1.25 to 37	V <sub>DC</sub>
Case Operating Temperature Range	-55 to +125	°C

## ELECTRICAL PERFORMANCE CHARACTERISTICS

Unless otherwise specified  $-55^{\circ}\text{C} \leq T_c \leq +125^{\circ}\text{C}$  &  $(V_{IN}-V_{OUT}) = 5V$ ,  $I_{OUT} = 0.5A$

PARAMETER	SYM	CONDITIONS ( $P \leq P_{MAX}$ )	MIN	MAX	UNITS
Reference Voltage <sup>1/</sup> <sup>5/</sup>	V <sub>REF</sub>	$3V \leq (V_{IN} - V_{OUT}) \leq V_{DIFF\ MAX}$ , $10mA \leq I_{OUT} \leq I_{MAX}$	1.20	1.30	V
Line Regulation <sup>1/</sup> <sup>2/</sup>	$\frac{\Delta V_{OUT}}{\Delta V_{IN}}$	$3V \leq (V_{IN} - V_{OUT}) \leq V_{DIFF\ MAX}$ , $I_{OUT} = 10mA$	-	0.06	%/V
Load Regulation <sup>1/</sup> <sup>2/</sup>	$\frac{\Delta V_{OUT}}{\Delta I_{OUT}}$	$10mA \leq I_{OUT} \leq I_{MAX}$ , $V_{OUT} \leq 5V$	-	60	mV
		$10mA \leq I_{OUT} \leq I_{MAX}$ , $V_{OUT} \geq 5V$	-	1.2	%
Thermal Regulation	-	$I_{OUT} = 1.5A$ , $(V_{IN} - V_{OUT}) = 13.3V$ , 20ms Pulse, 20W, $T_c = +25^{\circ}\text{C}$	-	0.07	%/W
Ripple Rejection Ratio	-	$V_{OUT} = 10V$ , $f = 120Hz$ , $C_{ADJ} = 10\mu F$	66	-	dB
Adjustment Pin Current <sup>1/</sup>	I <sub>ADJ</sub>	-	-	100	μA
Adjustment Pin Current Change <sup>1/</sup>	ΔI <sub>ADJ</sub>	$10mA \leq I_{OUT} \leq I_{MAX}$	-	5	μA
		$3V \leq (V_{IN} - V_{OUT}) \leq 40V$ ,			
Minimum Load Current <sup>1/</sup> <sup>3/</sup>	I <sub>MIN</sub>	$(V_{IN} - V_{OUT}) = 40V$	-	5	mA
Current Limit <sup>1/</sup> <sup>4/</sup>	I <sub>MAX</sub>	$(V_{IN} - V_{OUT}) \leq 15V$	1.50	-	A
		$(V_{IN} - V_{OUT}) = 40V$ , $T_c = +25^{\circ}\text{C}$	0.30	-	
Long Term Stability <sup>3/</sup>	$\frac{\Delta V_{OUT}}{\Delta TIME}$	$T_A = +125^{\circ}\text{C}$	-	1	%
Thermal Resistance (Junction to Case) <sup>3/</sup>	Θ <sub>JC</sub>	-	-	3	°C/W

Notes:

<sup>1/</sup> Specification derated to reflect Total Dose exposure to 100Krad (Si) @ +25°C.

<sup>2/</sup> Regulation is measured at a constant junction temperature, using pulse testing with a low duty cycle. Changes in output voltage due to heating effects are covered under the specification for thermal regulation. Measurements taken at the output lead must be adjusted for lead resistance.

<sup>3/</sup> Not tested. Shall be guaranteed to the specified limits.

<sup>4/</sup> Pulsed at <10% duty cycle @ 25°C.

<sup>5/</sup> Testing over 12 watts is not performed over + 25°C.

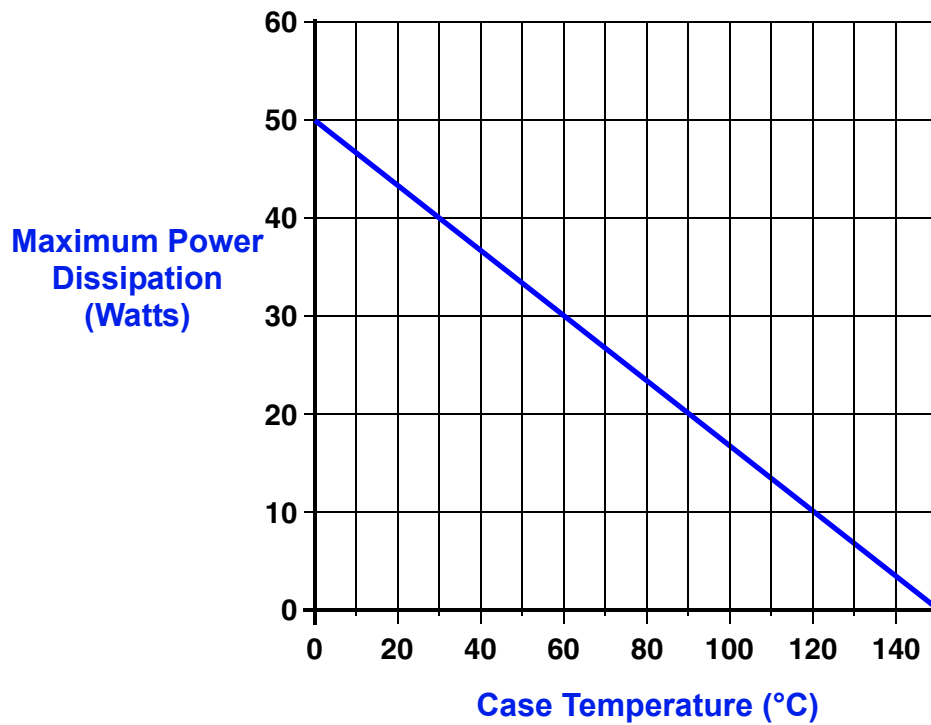

The maximum Power dissipation is limited by the thermal shutdown function of the regulator chip in the VRG8660. The graph above represents the achievable power before the chip shuts down. The line in the graph represents the maximum power dissipation of the VRG8660. This graph is based on the maximum junction temperature of 150°C and a thermal resistance ( $\theta_{JC}$ ) of 3°C/W.

**FIGURE 2 – MAXIMUM POWER vs CASE TEMPERATURE**

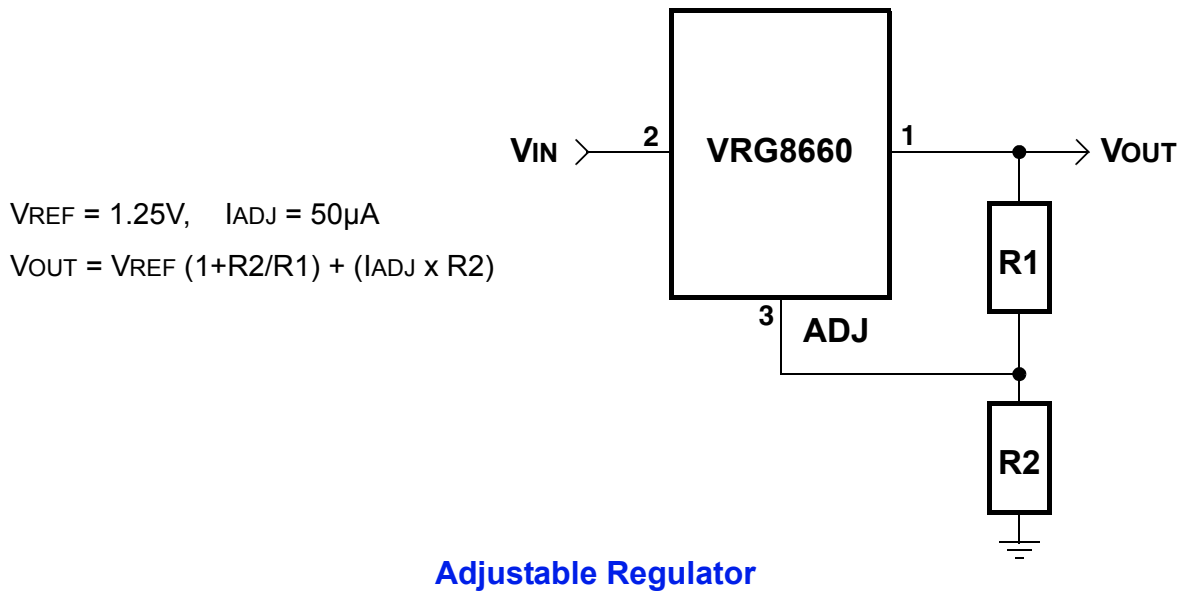

**FIGURE 3 - TYPICAL APPLICATIONS**

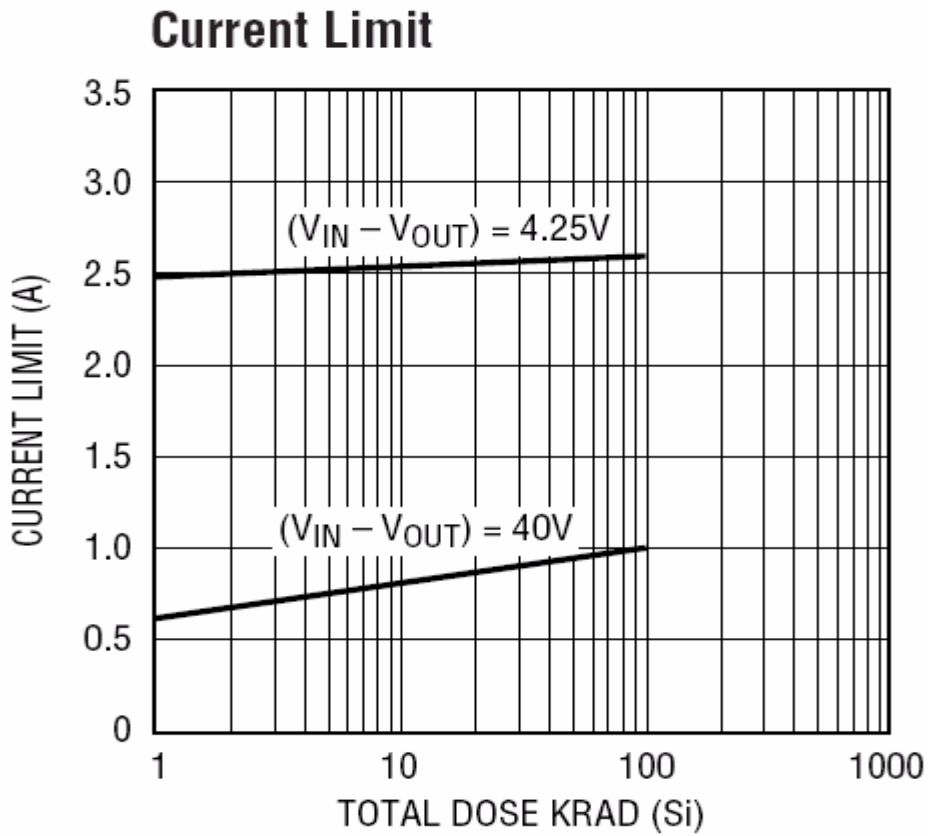

**FIGURE 4 - TYPICAL CURRENT LIMIT**

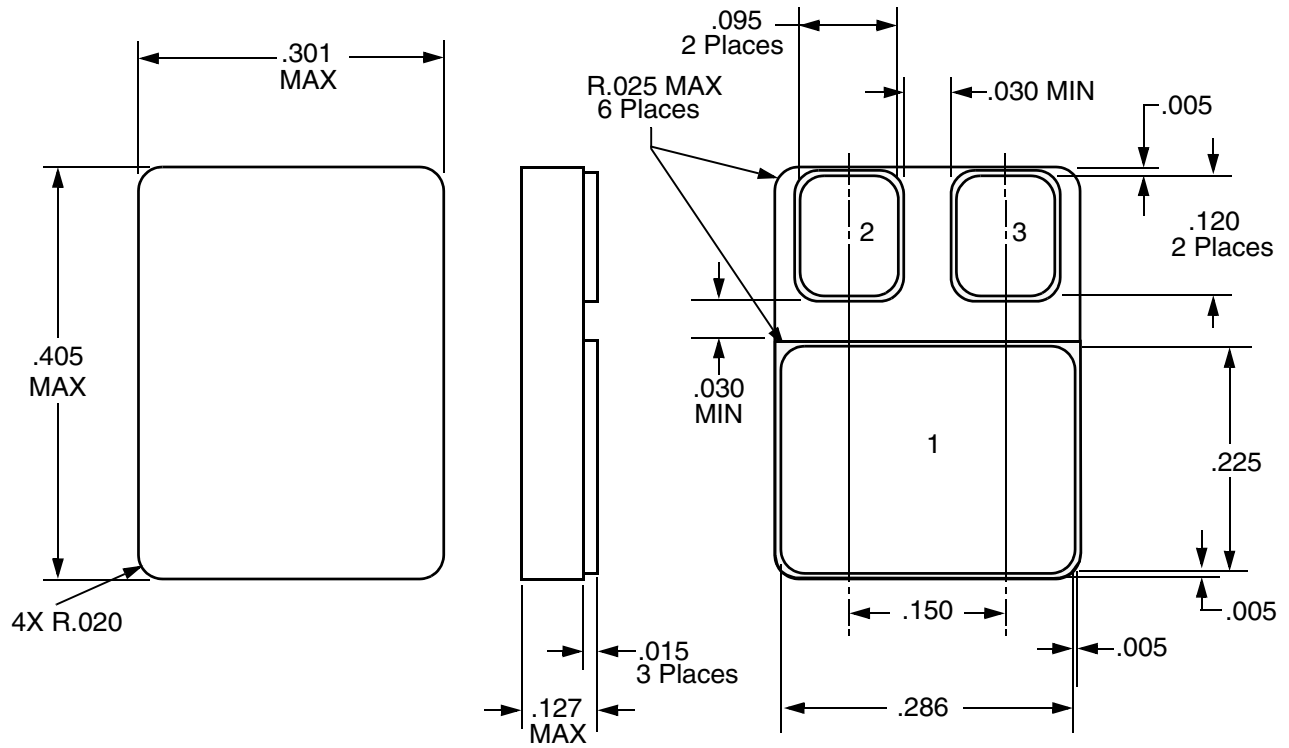

NOTE: 1. Package And Lid are electrically isolated from signal pads

**FIGURE 5 – PACKAGE OUTLINE— SURFACE MOUNT**

## ORDERING INFORMATION

MODEL	DLA SMD #	SCREENING	PACKAGE
VRG8660-7	-	Commercial Flow, +25°C testing only	SMD-0.5 Power Pkg
VRG8660-S	-	Military Temperature, -55°C to +125°C Screened in accordance with the individual Test Methods of MIL-STD-883 for Space Applications	
VRG8660-201-1S	5962-0920601KXC	In accordance with DLA SMD	
VRG8660-201-2S	5962-0920601KXA		
VRG8660-901-1S	5962R0920601KXC	In accordance with DLA Certified RHA Program Plan to RHA Level "R", 100krads(Si)	
VRG8660-901-2S	5962R0920601KXA		

For detailed performance characteristic curves, applications information and typical applications see the latest  datasheet for their RH117, which is available on-line at [www.linear.com](http://www.linear.com).

**EXPORT CONTROL:**

*This product is controlled for export under the International Traffic in Arms Regulations (ITAR). A license from the U.S. Department of State is required prior to the export of this product from the United States.*

**EXPORT WARNING:**

*Aeroflex's military and space products are controlled for export under the International Traffic in Arms Regulations (ITAR) and may not be sold or proposed or offered for sale to certain countries. (See ITAR 126.1 for complete information.)*

**PLAINVIEW, NEW YORK**  
Toll Free: 800-THE-1553  
Fax: 516-694-6715

**INTERNATIONAL**  
Tel: 805-778-9229  
Fax: 805-778-1980

**NORTHEAST**  
Tel: 603-888-3975  
Fax: 603-888-4585

**SE AND MID-ATLANTIC**  
Tel: 321-951-4164  
Fax: 321-951-4254

**WEST COAST**  
Tel: 949-362-2260  
Fax: 949-362-2266

**CENTRAL**  
Tel: 719-594-8017  
Fax: 719-594-8468



[www.aeroflex.com](http://www.aeroflex.com)    [info-ams@aeroflex.com](mailto:info-ams@aeroflex.com)

Aeroflex Microelectronic Solutions reserves the right to change at any time without notice the specifications, design, function, or form of its products described herein. All parameters must be validated for each customer's application by engineering. No liability is assumed as a result of use of this product. No patent licenses are implied.



Our passion for performance is defined by three attributes represented by these three icons: solution-minded, performance-driven and customer-focused

LT, LTC, , Linear Technology and the Linear logo are registered trademarks and RH117 is copyright Linear Technology Corporation.