

Voltage Regulator VRG8660

Adjustable Positive Voltage Regulator

Released Datasheet

Cobham.com/HiRel

March 24, 2016

COBHAM

The most important thing we build is trust

FEATURES

- Manufactured using  Space Qualified RH117 die
 - Radiation performance
 - Total dose: ≥ 100 krad(Si), Dose rate = 50-300 rad(Si)/s
 - ELDRS: ≥ 50 krad(Si), Dose rate = 0.01 rad(Si)/s
 - Thermal shutdown
 - Output voltage adjustable: 1.25V to 37V
 - 3-Terminal
 - Output current: 1.5A
 - Voltage reference: 1.25V $\pm 4\%$
 - Load regulation: 1.9% max
 - Line regulation: 0.06%/V max
 - Ripple rejection: >66dB
 - Packaging – Hermetic Ceramic
 - SMD-0.5 Surface mount
 - 3 Pads, .400"L x .296"W x .120"Ht
 - Power package
 - Weight - 2 gm max
 - Designed for aerospace and high reliability space applications
- Radiation Hardness Assurance Plan: DLA Certified to MIL-PRF-38534, Appendix G.**

DESCRIPTION

The VRG8660 consists of a Positive Adjustable (RH117) voltage regulator capable of supplying 1.5Amps over the output voltage range as defined under recommended operating conditions. The VRG8660 offers excellent line and load regulation specifications and ripple rejection. The VRG8660 serves a wide variety of applications including High Efficiency Linear Regulators, Post Regulators for Switching Supplies, Constant Current Regulators, Battery Chargers and Microprocessor Supply.

The VRG8660 has been specifically designed to meet exposure to radiation environments and is configured for a SMD-0.5 SMT power package. It is guaranteed operational from -55°C to $+125^{\circ}\text{C}$. Available screened to MIL-STD-883, the VRG8660 is ideal for demanding military and space applications.

Dropout ($V_{IN} - V_{OUT}$) decreases at lower load currents.

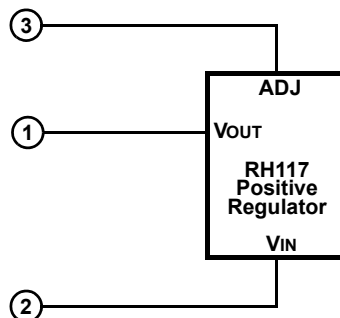

FIGURE 1 – BLOCK DIAGRAM / SCHEMATIC

ABSOLUTE MAXIMUM RATINGS

PARAMETER	RANGE	UNITS
Lead temperature (soldering 10 Sec)DC	300	°C
Input-Output Voltage Differential	40	V _{DC}
ESD	1.999 ^{1/}	KV
Operating Junction Temperature Range	-55 to +150	°C
Storage Temperature Range	-65 to +150	°C

^{1/} Meets ESD testing per MIL-STD-883, method 3015, Class 1C.

NOTICE: Stresses above those listed under "Absolute Maximum Ratings" may cause permanent damage to the device. These are stress rating only; functional operation beyond the "Operation Conditions" is not recommended and extended exposure beyond the "Operation Conditions" may effect device reliability.

RECOMMENDED OPERATING CONDITIONS

PARAMETER	RANGE	UNITS
Output Voltage Range	1.25 to 37	V _{DC}
Case Operating Temperature Range	-55 to +125	°C

ELECTRICAL PERFORMANCE CHARACTERISTICS

Unless otherwise specified $-55^{\circ}\text{C} \leq T_c \leq +125^{\circ}\text{C}$ & $(V_{IN}-V_{OUT}) = 5V$, $I_{OUT} = 0.5A$

PARAMETER	SYM	CONDITIONS ($P \leq P_{MAX}$)	MIN	MAX	UNITS
Reference Voltage ^{1/} ^{5/}	V _{REF}	$3V \leq (V_{IN} - V_{OUT}) \leq V_{DIFF\ MAX}$, $10mA \leq I_{OUT} \leq I_{MAX}$	1.20	1.30	V
Line Regulation ^{1/} ^{2/}	$\frac{\Delta V_{OUT}}{\Delta V_{IN}}$	$3V \leq (V_{IN} - V_{OUT}) \leq V_{DIFF\ MAX}$, $I_{OUT} = 10mA$	-	0.06	%/V
Load Regulation ^{1/} ^{2/}	$\frac{\Delta V_{OUT}}{\Delta I_{OUT}}$	$10mA \leq I_{OUT} \leq I_{MAX}$, $V_{OUT} \leq 5V$	-	60	mV
		$10mA \leq I_{OUT} \leq I_{MAX}$, $V_{OUT} \geq 5V$	-	1.2	%
Thermal Regulation	-	$I_{OUT} = 1.5A$, $(V_{IN} - V_{OUT}) = 13.3V$, 20ms Pulse, 20W, $T_c = +25^{\circ}\text{C}$	-	0.07	%/W
Ripple Rejection Ratio	-	$V_{OUT} = 10V$, $f = 120Hz$, $C_{ADJ} = 10\mu F$	66	-	dB
Adjustment Pin Current ^{1/}	I _{ADJ}	-	-	100	μA
Adjustment Pin Current Change ^{1/}	ΔI _{ADJ}	$10mA \leq I_{OUT} \leq I_{MAX}$	-	5	μA
		$3V \leq (V_{IN} - V_{OUT}) \leq 40V$,			
Minimum Load Current ^{1/} ^{3/}	I _{MIN}	$(V_{IN} - V_{OUT}) = 40V$	-	5	mA
Current Limit ^{1/} ^{4/}	I _{MAX}	$(V_{IN} - V_{OUT}) \leq 15V$	1.50	-	A
		$(V_{IN} - V_{OUT}) = 40V$, $T_c = +25^{\circ}\text{C}$	0.30	-	
Long Term Stability ^{3/}	$\frac{\Delta V_{OUT}}{\Delta TIME}$	$T_A = +125^{\circ}\text{C}$	-	1	%
Thermal Resistance (Junction to Case) ^{3/}	Θ _{JC}	-	-	3	°C/W

Notes:

^{1/} Specification derated to reflect Total Dose exposure to 100 krad(Si) @ +25°C.

^{2/} Regulation is measured at a constant junction temperature, using pulse testing with a low duty cycle. Changes in output voltage due to heating effects are covered under the specification for thermal regulation. Measurements taken at the output lead must be adjusted for lead resistance.

^{3/} Not tested. Shall be guaranteed to the specified limits.

^{4/} Pulsed at <10% duty cycle @ 25°C.

^{5/} Testing over 12 watts is not performed over + 25°C.

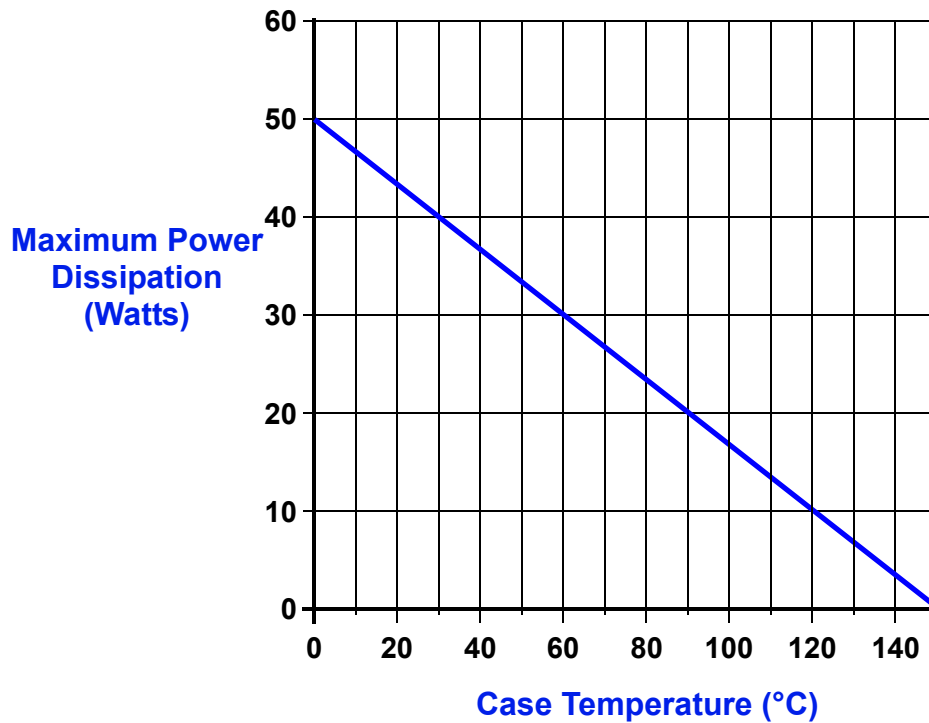

The maximum Power dissipation is limited by the thermal shutdown function of the regulator chip in the VRG8660. The graph above represents the achievable power before the chip shuts down. The line in the graph represents the maximum power dissipation of the VRG8660. This graph is based on the maximum junction temperature of 150°C and a thermal resistance (θ_{JC}) of 3°C/W.

FIGURE 2 – MAXIMUM POWER vs CASE TEMPERATURE

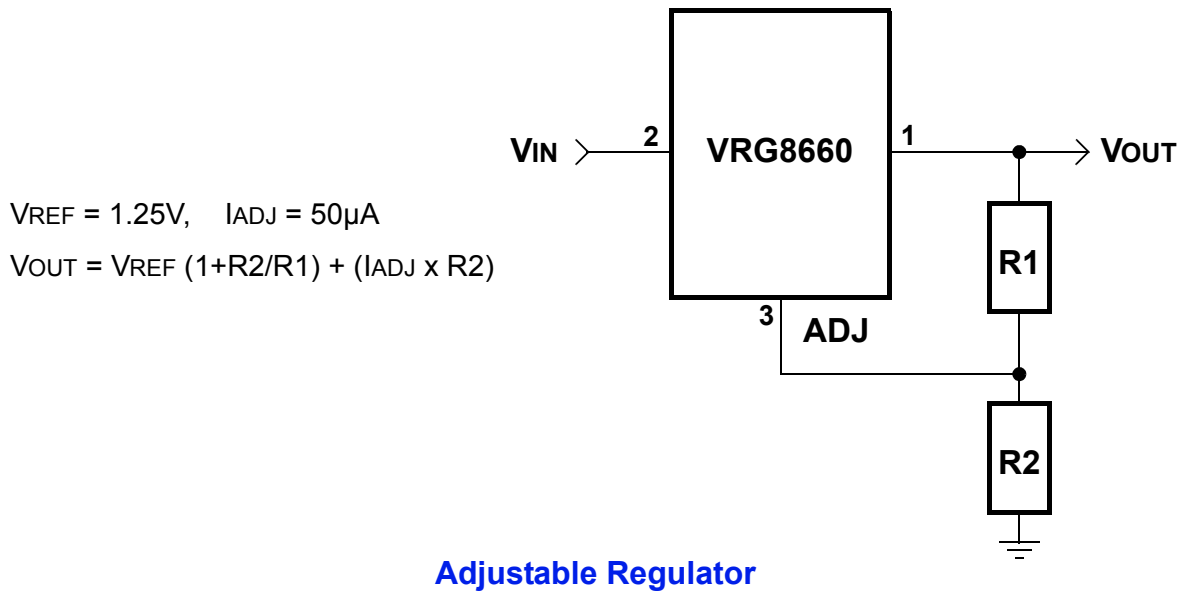

FIGURE 3 - TYPICAL APPLICATIONS

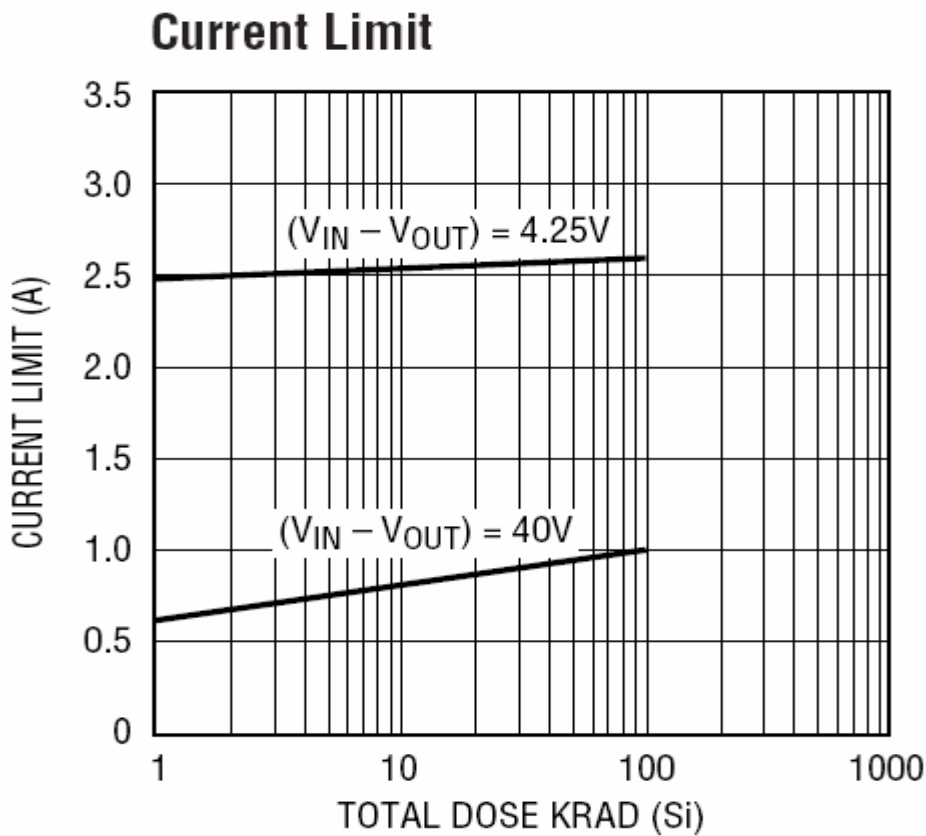
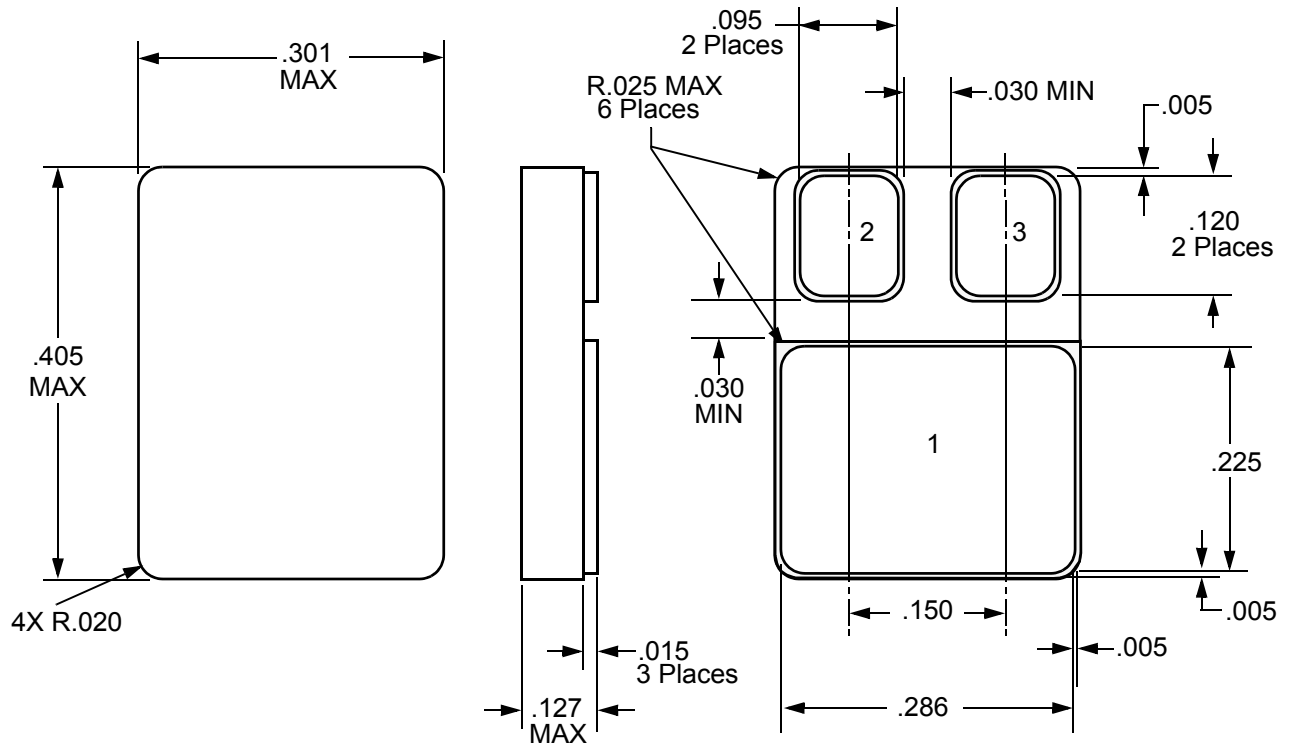

FIGURE 4 - TYPICAL CURRENT LIMIT



NOTE: 1. Package And Lid are electrically isolated from signal pads

FIGURE 5 – PACKAGE OUTLINE— SURFACE MOUNT

ORDERING INFORMATION

MODEL	DLA SMD #	SCREENING	PACKAGE
VRG8660-7	-	Commercial Flow, +25°C testing only	SMD-0.5 Power Pkg
VRG8660-S	-	Military Temperature, -55°C to +125°C Screened in accordance with the individual Test Methods of MIL-STD-883 for Space Applications	
VRG8660-201-1S	5962-0920601KXC	In accordance with DLA SMD	
VRG8660-201-2S	5962-0920601KXA		
VRG8660-901-1S	5962R0920601KXC	In accordance with DLA Certified RHA Program Plan to RHA Level "R", 100 krad(Si)	
VRG8660-901-2S	5962R0920601KXA		

REVISION HISTORY

Date	Revision	Change Description
03/24/2016	G	Import into Cobham format

Datasheet Definition

Advanced Datasheet - Product In Development

Preliminary Datasheet - Shipping Prototype

Datasheet - Shipping QML & Reduced Hi-Rel

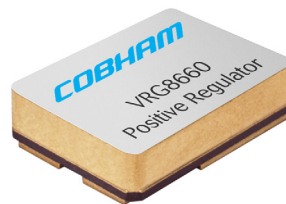

For detailed performance characteristic curves, applications information and typical applications, see the latest  datasheet for their RH117, which is available on-line at www.linear.com.

LT, LTC, Linear Technology and the Linear logo are registered trademarks and RH117 is copyright Linear Technology Corporation.

EXPORT CONTROL:

This product is controlled for export under the Export Administration Regulations (EAR), 15 CFR Parts 730-774. A license from the Department of Commerce may be required prior to the export of this product from the United States.

Cobham Semiconductor Solutions
35 S. Service Road
Plainview, NY 11803

E: info-ams@cobham.com
T: 800 645 8862

COBHAM

Aeroflex Plainview Inc., DBA Cobham Semiconductor Solutions, reserves the right to make changes to any products and services described herein at any time without notice. Consult Aeroflex or an authorized sales representative to verify that the information in this data sheet is current before using this product. Aeroflex does not assume any responsibility or liability arising out of the application or use of any product or service described herein, except as expressly agreed to in writing by Aeroflex; nor does the purchase, lease, or use of a product or service from Aeroflex convey a license under any patent rights, copyrights, trademark rights, or any other of the intellectual rights of Aeroflex or of third parties.