

# Voltage Regulator VRG8662

1A LDO Adjustable Positive Voltage Regulator

Released Datasheet

[Cobham.com/HiRel](http://Cobham.com/HiRel)

March 24, 2016

# COBHAM

The most important thing we build is trust

## FEATURES

- ❑ Manufactured using  Space Qualified RH1086 die
  - ❑ Radiation performance
    - Total dose:  $\geq 100$  krad(Si), Dose rate = 50-300 rad(Si)/s
    - ELDRS:  $\geq 50$  krad(Si), Dose rate = 0.01 rad(Si)/s
  - ❑ Thermal shutdown
  - ❑ Output voltage adjustable: 1.25V to 23V
  - ❑ Dropout voltage: 1.3V at 1.0 Amps
  - ❑ 3-Terminal
  - ❑ Output current: 1.0A (See Note 1, pg 2)
  - ❑ Voltage reference: 1.25V +2%, -3.2%
  - ❑ Load regulation: 0.3% max
  - ❑ Line regulation: 0.25% max
  - ❑ Ripple rejection: >60dB
  - ❑ Packaging – Hermetic Ceramic
    - SMD-0.5 Surface mount
    - 3 Pads, .400"L x .296"W x .120"Ht
    - Power package
    - Weight - 2 gm max
  - ❑ Designed for aerospace and high reliability space applications
- ❑ **Radiation Hardness Assurance Plan: DLA Certified to MIL-PRF-38534, Appendix G.**

## DESCRIPTION

The VRG8662 consists of a Positive Adjustable (RH1086) LDO voltage regulator capable of supplying 1.0 Amps over the output voltage range as defined under recommended operating conditions. The VRG8662 offers excellent line and load regulation specifications and ripple rejection. Dropout ( $V_{IN} - V_{OUT}$ ) decreases at lower load currents.

The VRG8662 serves a wide variety of applications including SCSI-2 Active Terminator, High Efficiency Linear Regulators, Post Regulators for Switching Supplies, Constant Current Regulators, Battery Chargers and Microprocessor Supply.

The VRG8662 has been specifically designed to meet exposure to radiation environments and is configured for a SMD-0.5 SMT power package. It is guaranteed operational from -55°C to +125°C. Available screened to MIL-STD-883, the VRG8662 is ideal for demanding military and space applications.

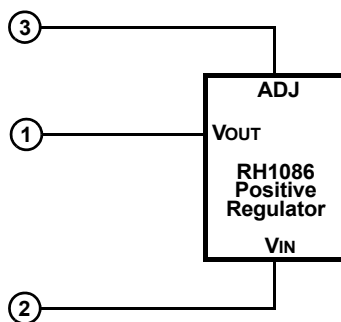

FIGURE 1 – BLOCK DIAGRAM / SCHEMATIC

## ABSOLUTE MAXIMUM RATINGS

PARAMETER	RANGE	UNITS
Input Voltage	+25+VREF	VDC
DC Output Current	1.5	A
Lead temperature (soldering 10 Sec)	300	°C
Input Output Differential	25	VDC
Output Voltage	+25	VDC
ESD (MIL-STD-883, M3015, Class 3A)	4000	V
Operating Junction Temperature Range	-55 to +150	°C
Storage Temperature Range	-65 to +150	°C

NOTICE: Stresses above those listed under "Absolute Maximum Ratings" may cause permanent damage to the device. These are stress rating only; functional operation beyond the "Operation Conditions" is not recommended and extended exposure beyond the "Operation Conditions" may effect device reliability.

## RECOMMENDED OPERATING CONDITIONS

PARAMETER	RANGE	UNITS
Output Voltage Range	1.275 to 23	VDC
Input Output Differential	1.5 to 25	VDC
Case Operating Temperature Range	-55 to +125	°C

## ELECTRICAL PERFORMANCE CHARACTERISTICS

Unless otherwise specified, -55°C ≤ Tc ≤ +125°C.

PARAMETER	SYM	CONDITIONS (P ≤ P <sub>MAX</sub> )	MIN	MAX	UNITS
Reference Voltage <u>2/</u> <u>3/</u>	VREF	10mA ≤ I <sub>OUT</sub> ≤ 1.0A, 1.5V ≤ V <sub>IN</sub> - V <sub>OUT</sub> ≤ 15V	1.210	1.275	V
Line Regulation <u>2/</u> <u>3/</u>	$\frac{\Delta V_{OUT}}{\Delta V_{IN}}$	I <sub>LOAD</sub> = 10mA, T <sub>j</sub> = +25°C, 1.5V ≤ V <sub>IN</sub> - V <sub>OUT</sub> ≤ 15V	-	0.25	%
Load Regulation <u>2/</u> <u>3/</u>	$\frac{\Delta V_{OUT}}{\Delta I_{OUT}}$	10mA ≤ I <sub>OUT</sub> ≤ 1.0A, (V <sub>IN</sub> - V <sub>OUT</sub> ) = 3V	-	0.40	%
Dropout Voltage <u>2/</u> <u>4/</u>	V <sub>DROP</sub>	DVREF = 1%, I <sub>OUT</sub> = 1.0A	-	1.30	V
Adjust Pin Current <u>2/</u>	-	-	-	120	μA
Adjust Pin Current Change <u>2/</u>	-	10 mA ≤ I <sub>OUT</sub> ≤ 1A, 1.5V ≤ V <sub>IN</sub> - V <sub>OUT</sub> ≤ 15V	-	5	μA
Current Limit <u>2/</u> <u>6/</u>	I <sub>MAX</sub>	V <sub>IN</sub> - V <sub>OUT</sub> = 5V	1.5	-	A
		V <sub>IN</sub> - V <sub>OUT</sub> ≤ 25V	0.047	-	A
Minimum Load Current <u>5/</u>	I <sub>MIN</sub>	V <sub>IN</sub> - V <sub>OUT</sub> = 25V	-	10	mA
Ripple Rejection <u>3/</u>	-	I <sub>OUT</sub> = 1.0A, (V <sub>IN</sub> - V <sub>OUT</sub> ) = 3V, f = 120Hz, C <sub>ADJ</sub> = C <sub>OUT</sub> = 25μF	60	-	dB
Thermal Regulation	-	30ms pulse, T <sub>c</sub> = +25°C	-	0.04	%/W
VREF Long-Term Stability <u>5/</u>	-	Burn In: T <sub>c</sub> = +125°C @ 1000hrs min. Tested at +25°C only.	-	0.30	%
Thermal Resistance (Junction to Case)	Θ <sub>JC</sub>	-	-	3	°C/W

Notes:

- 1/ For compliance with MIL-STD- 883 revision C current density specification, the RH1086MK is derated to 1 Amp but is capable of 1.5 Amps.
- 2/ Specification derated to reflect Total Dose exposure to 100 krad(Si) @+25°C
- 3/ Line and load regulation are guaranteed up to the maximum power dissipation of 15W. Power dissipation is determined by the input/output differential voltage and the output current. Guaranteed maximum power dissipation will not be available over the full input/output voltage range.
- 4/ Dropout voltage is specified over the full output current range of the device.
- 5/ Not tested. Shall be guaranteed by design, characterization, or correlation to other tested parameters.
- 6/ Pulsed @ <10% duty cycle @+25°C for characterization only. (See note 1)

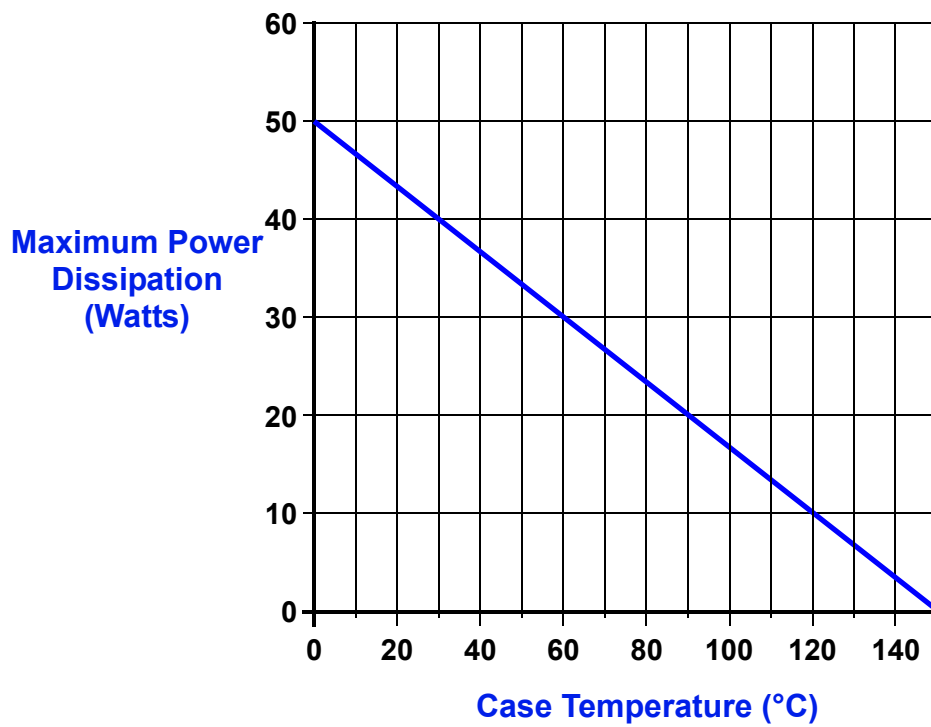

The maximum Power dissipation is limited by the thermal shutdown function of the regulator chip in the VRG8662. The graph above represents the achievable power before the chip shuts down. The line in the graph represents the maximum power dissipation of the VRG8662. This graph is based on the maximum junction temperature of 150°C and a thermal resistance ( $\Theta_{JC}$ ) of 3°C/W.

**FIGURE 2 – MAXIMUM POWER vs CASE TEMPERATURE**

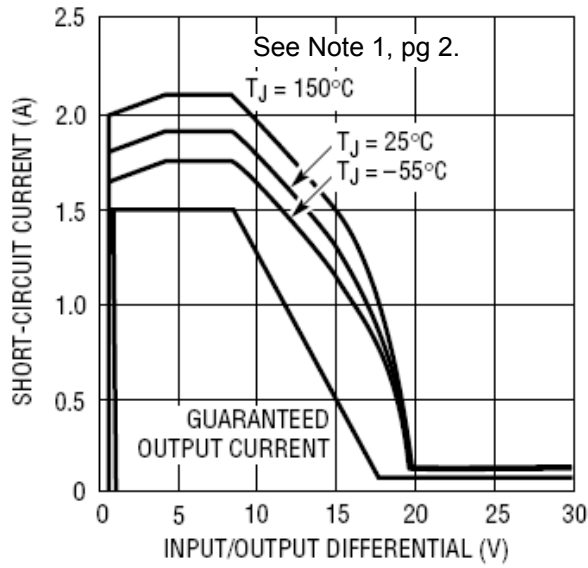

FIGURE 3 – RH1086 SHORT CIRCUIT CURRENT

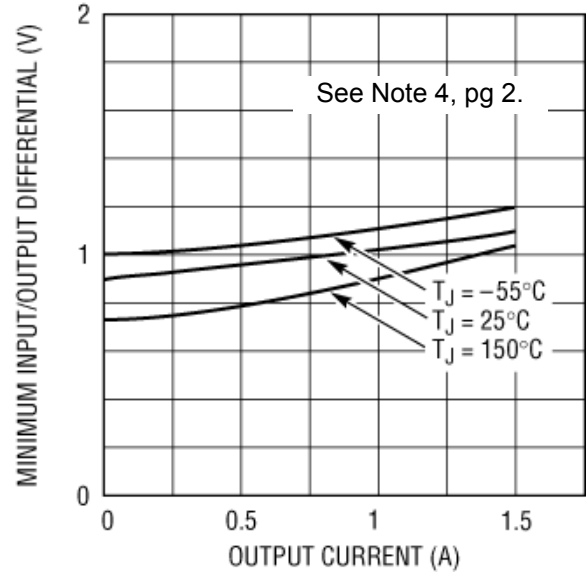

FIGURE 4 – RH1086 TYPICAL DROPOUT VOLTAGE CURVE

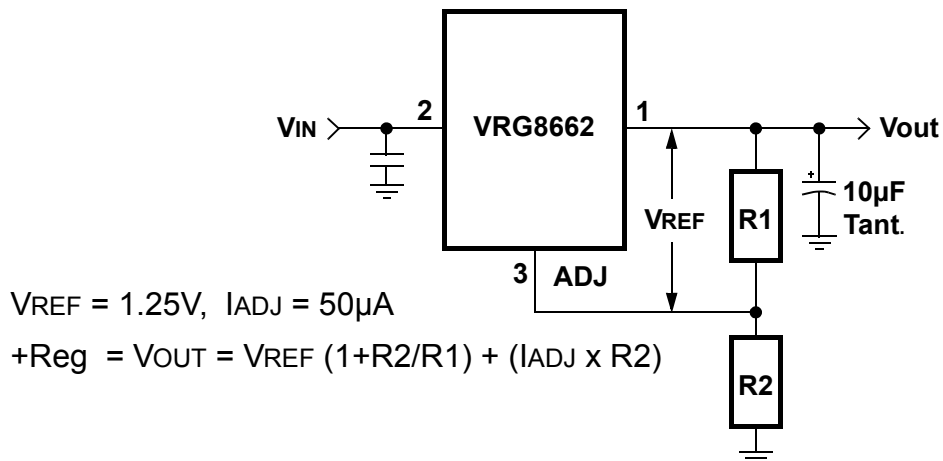
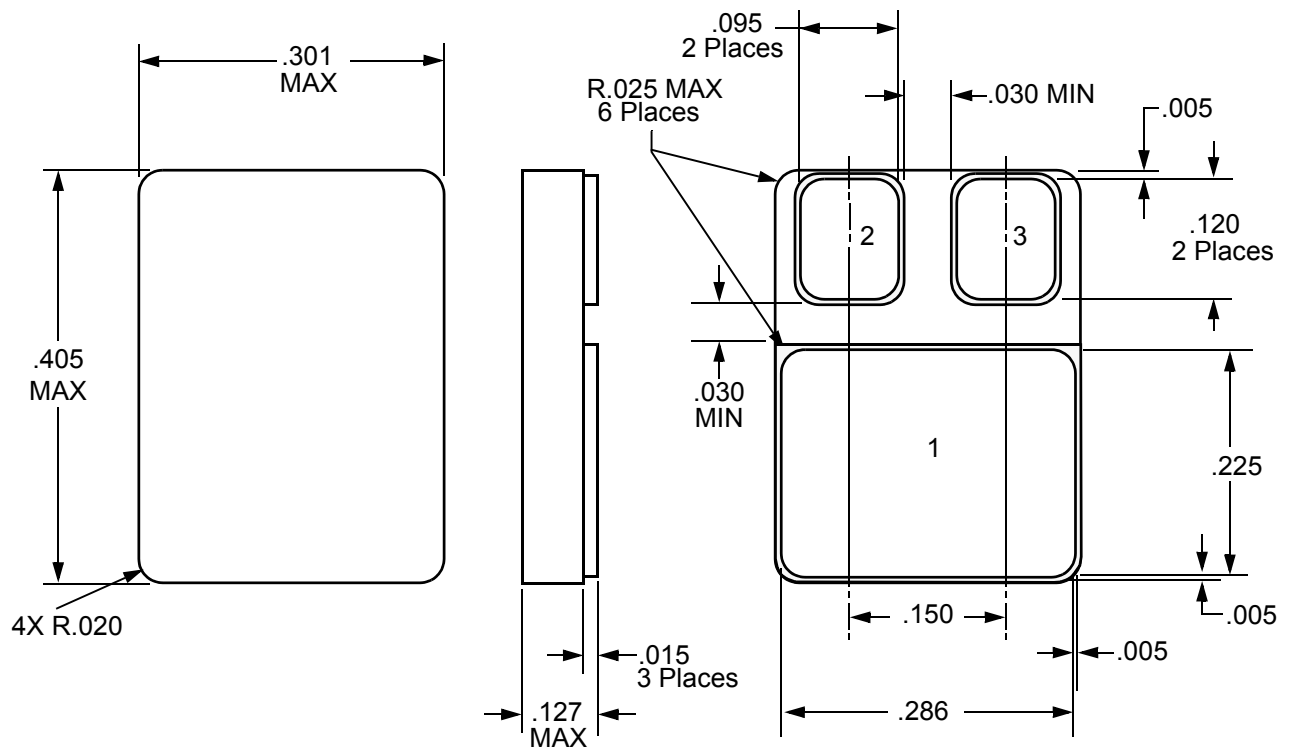

FIGURE 5 – BASIC RH1086 ADJUSTABLE REGULATOR APPLICATION



**NOTES:**

1. Package & Lid are electrically isolated from signal pads
2. ESD symbol denotes Pin 1

**FIGURE 6 – PACKAGE OUTLINE — SURFACE MOUNT**

## ORDERING INFORMATION

MODEL	DLA SMD #	SCREENING	PACKAGE
VRG8662-7	-	Commercial Flow, +25°C testing only	SMD-0.5 Power Pkg
VRG8662-S	-	Military Temperature, -55°C to +125°C Screened in accordance with the individual Test Methods of MIL-STD-883 for Space Applications	
VRG8662-201-1S	5962-0920701KXC	In accordance with DLA SMD	
VRG8662-201-2S	5962-0920701KXA		
VRG8662-901-1S	5962R0920701KXC	In accordance with DLA Certified RHA Program Plan to RHA Level "R", 100 krad(Si)	
VRG8662-901-2S	5962R0920701KXA		

## REVISION HISTORY

Date	Revision	Change Description
03/24/2016	H	Import into Cobham format

## *Datasheet Definition*

**Advanced Datasheet - Product In Development**

**Preliminary Datasheet - Shipping Prototype**

**Datasheet - Shipping QML & Reduced Hi-Rel**



For detailed performance characteristic curves, applications information and typical applications, see the latest



datasheet for their RH1086, which is available on-line at [www.linear.com](http://www.linear.com).

LT, LTC, Linear Technology and the Linear logo are registered trademarks and RH1086 is copyright Linear Technology Corporation.

### **EXPORT CONTROL:**

*This product is controlled for export under the Export Administration Regulations (EAR), 15 CFR Parts 730-774.*

*A license from the Department of Commerce may be required prior to the export of this product from the United States.*

**Cobham Semiconductor Solutions**  
35 S. Service Road  
Plainview, NY 11803

**E: [info-ams@cobham.com](mailto:info-ams@cobham.com)**  
**T: 800 645 8862**

# **COBHAM**

Aeroflex Plainview Inc., DBA Cobham Semiconductor Solutions, reserves the right to make changes to any products and services described herein at any time without notice. Consult Aeroflex or an authorized sales representative to verify that the information in this data sheet is current before using this product. Aeroflex does not assume any responsibility or liability arising out of the application or use of any product or service described herein, except as expressly agreed to in writing by Aeroflex; nor does the purchase, lease, or use of a product or service from Aeroflex convey a license under any patent rights, copyrights, trademark rights, or any other of the intellectual rights of Aeroflex or of third parties.