

Features

- P-Channel, -5V Logic Level Control
- Enhancement mode
- Low on-resistance $R_{DS(on)}$ @ $V_{GS}=-4.5V$
- Fast Switching and High efficiency
- 100% Avalanche Tested
- Pb-free lead plating; RoHS compliant



Part ID	Package Type	Marking	Tape and reel information
VS3503AT	TO-220AB	3503AT	50pcs/Tube

V_{DS}	-30	V
$R_{DS(on),TYP}$ @ $V_{GS}=-10V$	3.7	m Ω
$R_{DS(on),TYP}$ @ $V_{GS}=-4.5V$	5.6	m Ω
I_D	-160	A

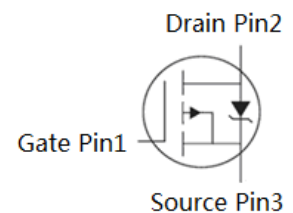
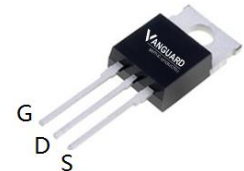
TO-220AB

Maximum ratings, at $T_A=25^\circ\text{C}$, unless otherwise specified

Symbol	Parameter	Rating	Unit
$V_{(BR)DSS}$	Drain-Source breakdown voltage	-30	V
V_{GS}	Gate-Source voltage	± 20	V
I_S	Diode continuous forward current	$T_C=25^\circ\text{C}$ -160	A
I_D	Continuous drain current @ $V_{GS}=-10V$	$T_C=25^\circ\text{C}$ -160	A
		$T_C=100^\circ\text{C}$ -110	A
I_{DM}	Pulse drain current tested ①	$T_C=25^\circ\text{C}$ -640	A
I_{DSM}	Continuous drain current @ $V_{GS}=-10V$	$T_A=25^\circ\text{C}$ -18	A
		$T_A=70^\circ\text{C}$ -15	A
EAS	Avalanche energy, single pulsed ②	365	mJ
P_D	Maximum power dissipation	$T_C=25^\circ\text{C}$ 150	W
P_{DSM}	Maximum power dissipation ③	$T_A=25^\circ\text{C}$ 2	W
T_{STG}, T_J	Storage and Junction Temperature Range	-55 to 175	$^\circ\text{C}$
Thermal Characteristics			
$R_{\theta JC}$	Thermal Resistance, Junction-to-Case	1	$^\circ\text{C/W}$
$R_{\theta JA}$	Thermal Resistance, Junction-to-Ambient	62.5	$^\circ\text{C/W}$

Symbol	Parameter	Condition	Min.	Typ.	Max.	Unit
Static Electrical Characteristics @ T_J = 25°C (unless otherwise stated)						
V _{(BR)DSS}	Drain-Source Breakdown Voltage	V _{GS} =0V, I _D =-250μA	-30	--	--	V
I _{DSS}	Zero Gate Voltage Drain Current	V _{DS} =-30V, V _{GS} =0V	--	--	-1	μA
	Zero Gate Voltage Drain Current(T _J =125°C)	V _{DS} =-30V, V _{GS} =0V	--	--	-100	μA
I _{GSS}	Gate-Body Leakage Current	V _{GS} =±20V, V _{DS} =0V	--	--	±100	nA
V _{GS(TH)}	Gate Threshold Voltage	V _{DS} =V _{GS} , I _D =-250μA	-1.2	-1.6	-2.3	V
R _{DS(ON)}	Drain-Source On-State Resistance ④	V _{GS} =-10V, I _D =-60A	--	3.7	5.2	mΩ
R _{DS(ON)}	Drain-Source On-State Resistance ④	V _{GS} =-4.5V, I _D =-40A	--	5.6	7.9	mΩ
Dynamic Electrical Characteristics @ T_J = 25°C (unless otherwise stated)						
C _{iss}	Input Capacitance	V _{DS} =-15V, V _{GS} =0V, f=1MHz	5350	6350	7350	pF
C _{oss}	Output Capacitance		700	1020	1340	pF
C _{rss}	Reverse Transfer Capacitance		665	865	1065	pF
R _g	Gate Resistance	f=1MHz	--	9.5	--	Ω
Q _g	Total Gate Charge	V _{DS} =-15V, I _D =-60A, V _{GS} =-10V	--	142	--	nC
Q _{gs}	Gate-Source Charge		--	22	--	nC
Q _{gd}	Gate-Drain Charge		--	34	--	nC
Switching Characteristics						
t _{d(on)}	Turn-on Delay Time	V _{DD} =-15V, I _D =-60A, R _G =3.0Ω, V _{GS} =-10V	--	14	--	ns
t _r	Turn-on Rise Time		--	15	--	ns
t _{d(off)}	Turn-Off Delay Time		--	90	--	ns
t _f	Turn-Off Fall Time		--	34	--	ns
Source- Drain Diode Characteristics @ T_J = 25°C (unless otherwise stated)						
V _{SD}	Forward on voltage	I _{SD} =-40A, V _{GS} =0V	--	-0.9	-1.2	V
t _{rr}	Reverse Recovery Time	T _J =25°C, I _{sd} =-60A, V _{GS} =0V	--	21	--	ns
Q _{rr}	Reverse Recovery Charge	di/dt=-100A/μs	--	57	--	nC

NOTE:

- ① Repetitive rating; pulse width limited by max junction temperature.
- ② Limited by T_{Jmax}, starting T_J = 25°C, L = 0.5mH, R_G = 25Ω, I_{AS} = -30A, V_{GS} = -10V. Part not recommended for use above this value
- ③ The power dissipation P_{DSM} is based on R_{θJA} and the maximum allowed junction temperature of 150°C.
- ④ Pulse width ≤ 300μs; duty cycles ≤ 2%.

Typical Characteristics

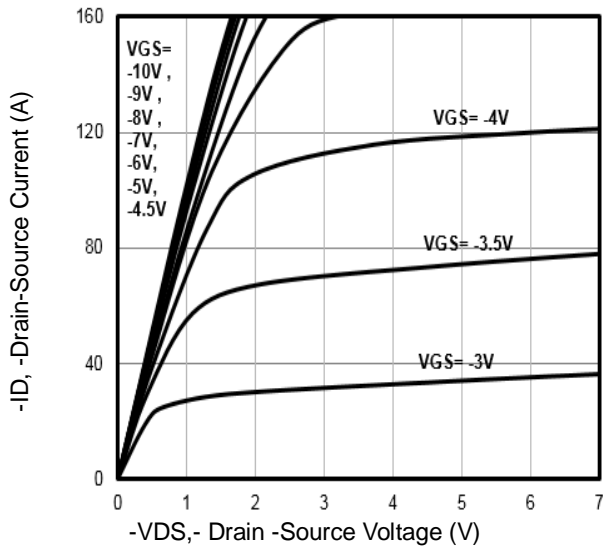

Fig1. Typical Output Characteristics

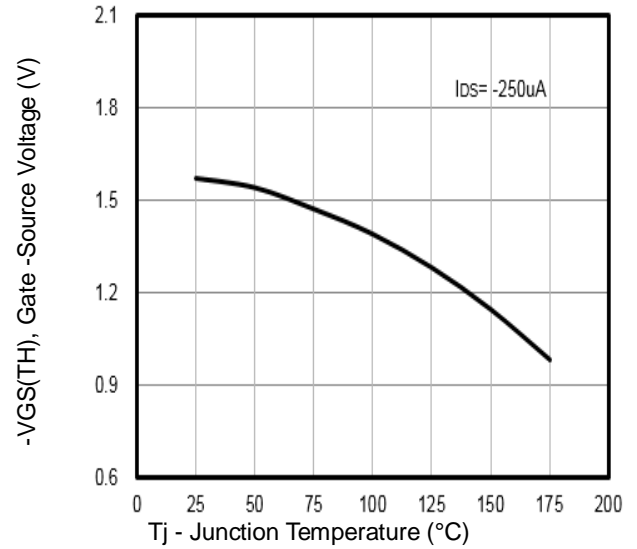

Fig2. $-V_{GS(TH)}$ Gate -Source Voltage Vs. T_j

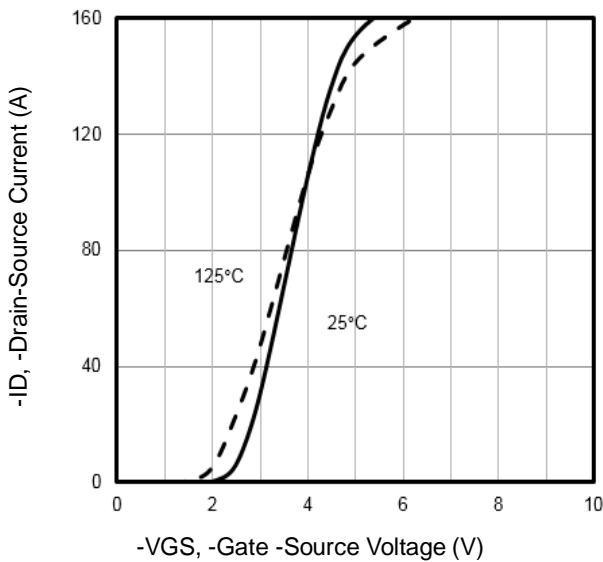

Fig3. Typical Transfer Characteristics

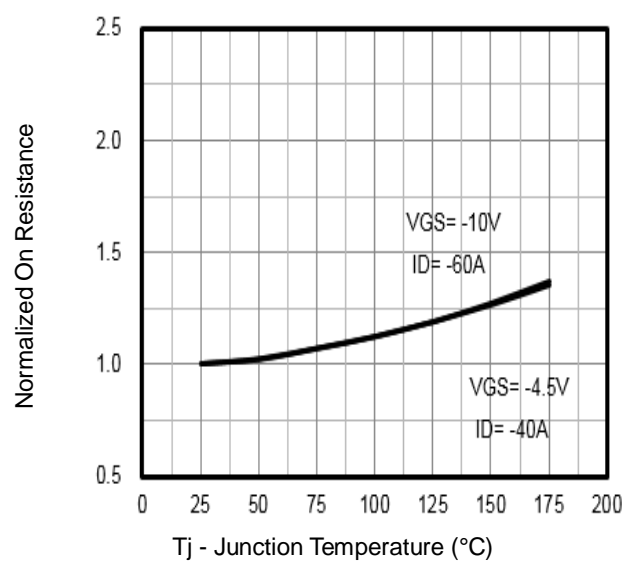

Fig4. Normalized On-Resistance Vs. T_j

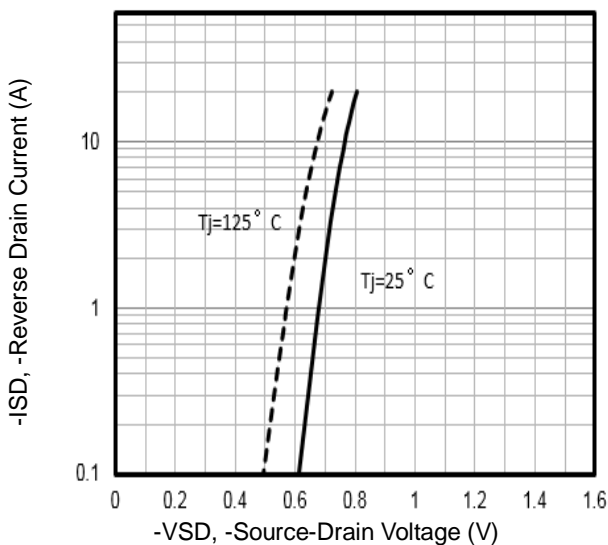

Fig5. Typical Source-Drain Diode Forward Voltage

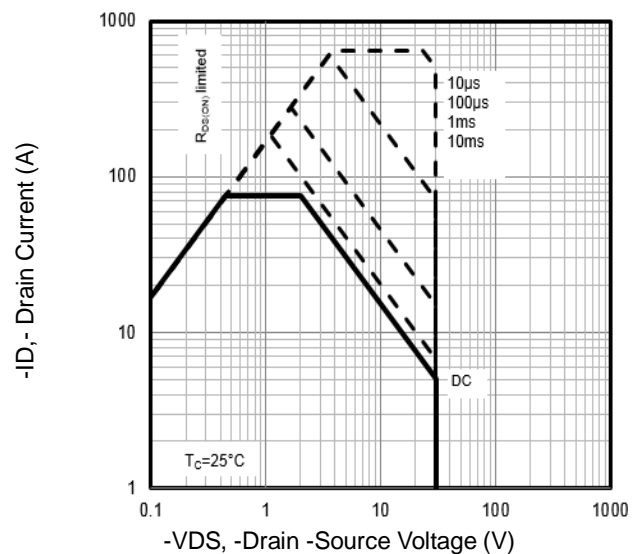

Fig6. Maximum Safe Operating Area

Typical Characteristics

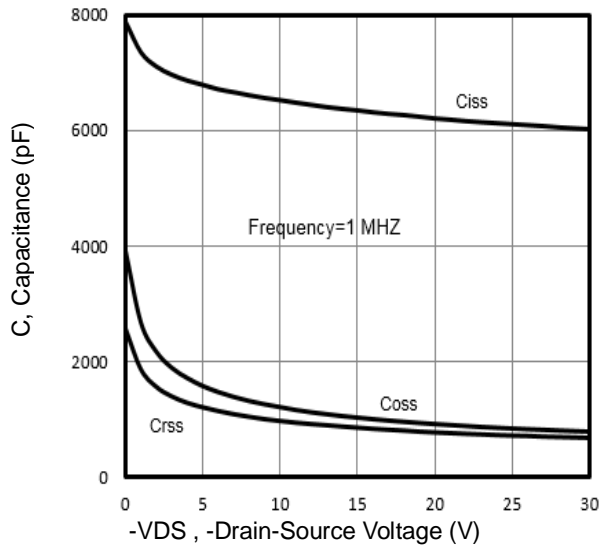

Fig7. Typical Capacitance Vs.Drain-Source Voltage

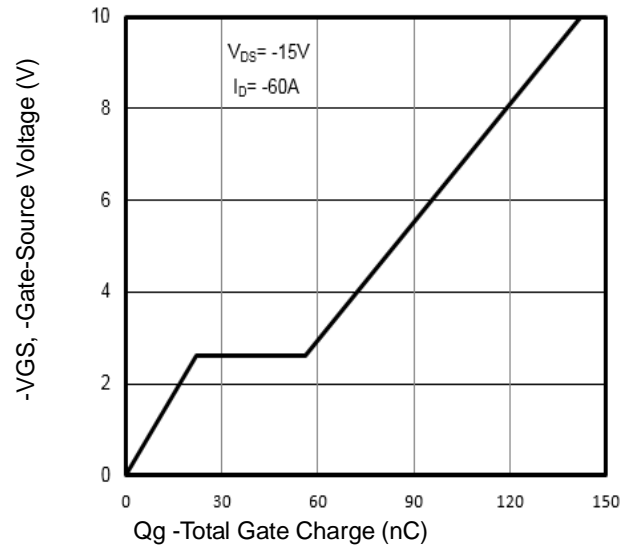

Fig8. Typical Gate Charge Vs.Gate-Source Voltage

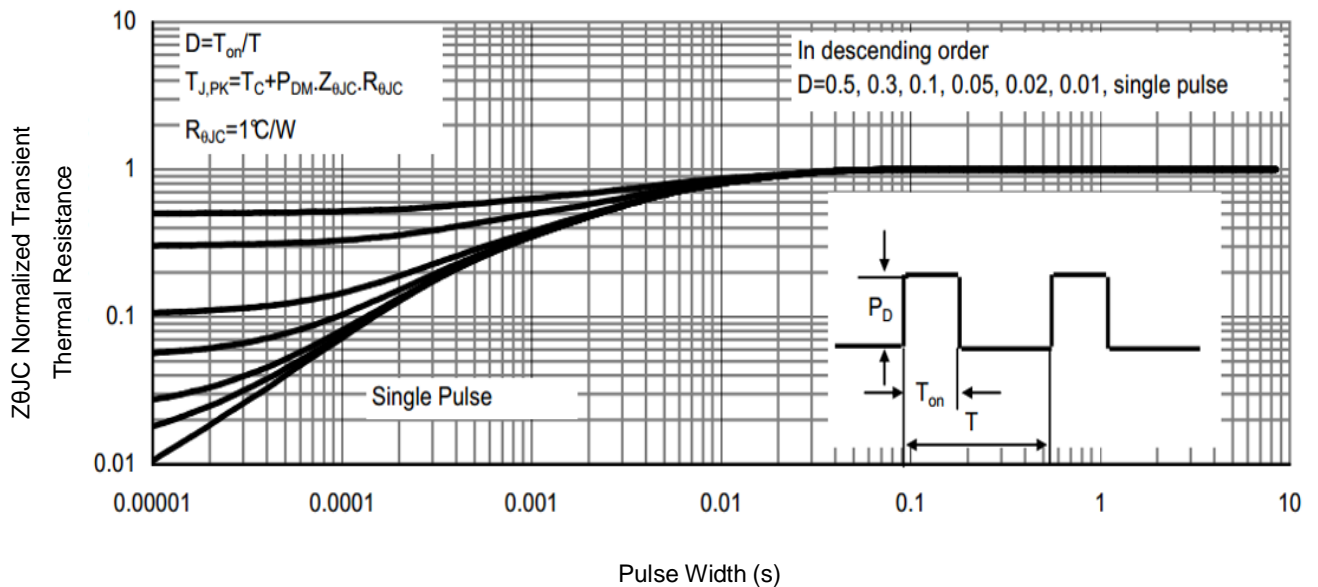

Fig9. Normalized Maximum Transient Thermal Impedance

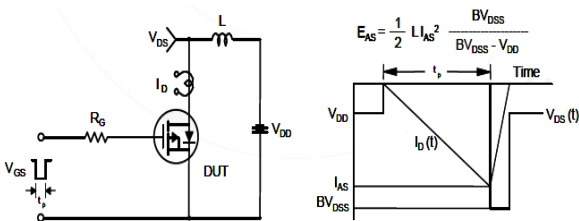

Fig10. Unclamped Inductive Test Circuit and Waveforms

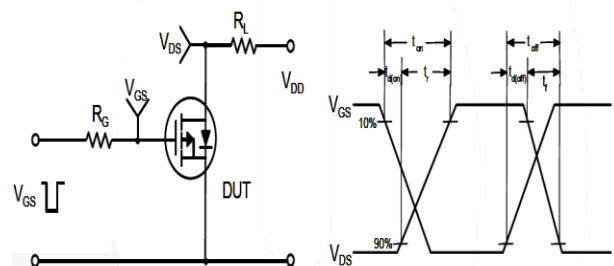
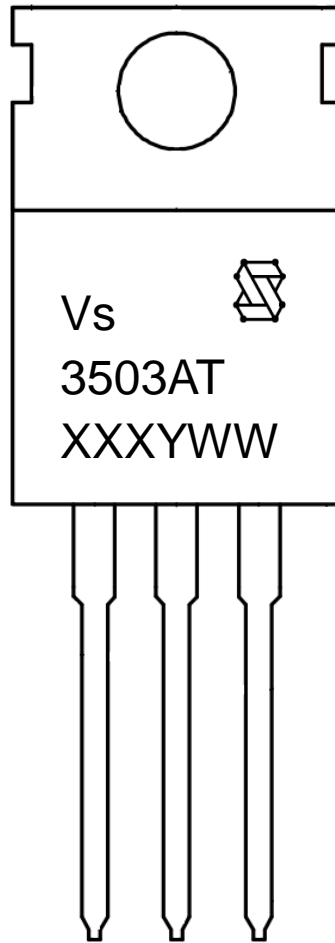

Fig11. Switching Time Test Circuit and waveforms



Marking Information



1st line: Vanguard Code (Vs), Vanguard Logo

2nd line: Part Number (3503AT)

3rd line: Date code (XXXYWW)

XXX: Wafer Lot Number

Y: Year Code, e.g. E means 2017

WW: Week Code

TO-220AB Package Outline Data

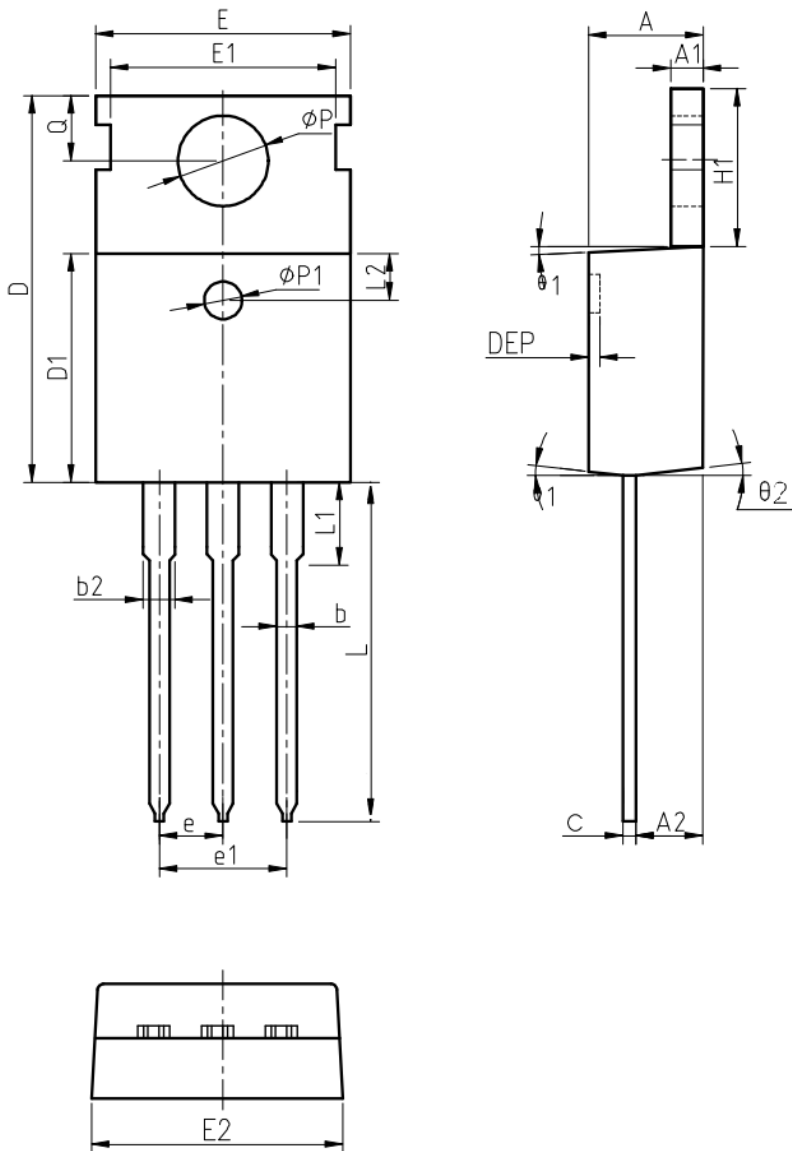

Symbol	Dimensions (unit: mm)		
	Min	Typ	Max
A	4.30	4.52	4.70
A1	1.15	1.30	1.40
A2	2.20	2.40	2.60
b	0.70	0.80	1.00
b2	1.17	1.32	1.50
c	0.45	0.50	0.61
D	15.30	15.65	15.90
D1	9.00	9.20	9.40
DEP	0.05	0.10	0.25
E	9.66	9.90	10.28
E1	-	8.70	-
E2	9.80	10.00	10.20
$\phi P1$	1.40	1.50	1.60
e	2.54 BSC		
e1	5.08 BSC		
H1	6.40	6.50	6.80
L	12.70	-	14.27
L1	-	-	3.95
L2	2.40	2.50	2.60
ϕP	3.53	3.60	3.70
Q	2.70	2.80	2.90
$\theta1$	5 °	7 °	9 °
$\theta2$	1 °	3 °	5 °

Notes:

1. Refer to JEDEC TO-220 variation AB
2. Dimension "D" and "E" do NOT include mold flash. Mold flash shall not exceed 0.127mm per side.

Customer Service

Sales and Service:

sales@vgsemi.com

Vanguard Semiconductor CO., LTD

TEL: (86-755) -26902410

FAX: (86-755) -26907027

WEB: www.vgsemi.com