

Features

- N-Channel, 5V Logic Level Control
- Enhancement mode
- Very low on-resistance $R_{DS(on)}$ @ $V_{GS}=4.5\text{ V}$
- Fast Switching
- 100% Avalanche Tested
- Pb-free lead plating; RoHS compliant

V_{DS}	45	V
$R_{DS(on),TYP}@ V_{GS}=10\text{ V}$	4.2	m Ω
$R_{DS(on),TYP}@ V_{GS}=4.5\text{ V}$	5.2	m Ω
I_D	105	A



TO-252

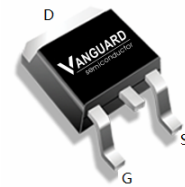

Drain Pin 2



Source Pin 3

Part ID	Package Type	Marking	Tape and reel information
VS40120AD	TO-252	40120AD	2500pcs/reel

Maximum ratings, at $T_j=25\text{ }^\circ\text{C}$, unless otherwise specified

Symbol	Parameter	Rating	Unit	
Common Ratings ($T_c=25^\circ\text{C}$ Unless Otherwise Noted)				
V_{GS}	Gate-Source Voltage	± 20	V	
$V_{(BR)DSS}$	Drain-Source Breakdown Voltage	45	V	
T_j	Maximum Junction Temperature	175	$^\circ\text{C}$	
T_{STG}	Storage Temperature Range	-55 to 150	$^\circ\text{C}$	
I_s	Diode Continuous Forward Current	$T_c=25^\circ\text{C}$ 105	A	
Mounted on Large Heat Sink				
I_D	Continuous Drain current@ $V_{GS}=10\text{V}$	$T_c=25^\circ\text{C}$	105	A
		$T_c=100^\circ\text{C}$	67	A
I_{DM}	Pulse Drain Current Tested ①	$T_c=25^\circ\text{C}$	350	A
P_D	Maximum Power Dissipation	$T_c=25^\circ\text{C}$	100	W
$R_{\theta JC}$	Thermal Resistance-Junction to Case		1.5	$^\circ\text{C/W}$
$R_{\theta JA}$	Thermal Resistance Junction-Ambient		48	$^\circ\text{C/W}$
Drain-Source Avalanche Ratings				
EAS	Avalanche Energy, Single Pulsed ③		56	mJ

Symbol	Parameter	Condition	Min.	Typ.	Max.	Unit
Static Electrical Characteristics @ T_c = 25°C (unless otherwise stated)						
V _{(BR)DSS}	Drain-Source Breakdown Voltage	V _{GS} =0V I _D =250μA	45	--	--	V
I _{DSS}	Zero Gate Voltage Drain Current(T _c =25°C)	V _{DS} =40V, V _{GS} =0V	--	--	1	μA
	Zero Gate Voltage Drain Current(T _c =125°C)	V _{DS} =40V, V _{GS} =0V	--	--	100	μA
I _{GSS}	Gate-Body Leakage Current	V _{GS} =±20V, V _{DS} =0V	--	--	±100	nA
V _{GS(TH)}	Gate Threshold Voltage	V _{DS} =V _{GS} , I _D =250μA	1.0	2.0	3.0	V
R _{DS(ON)}	Drain-Source On-State Resistance ^②	V _{GS} =10V, I _D =50A	--	4.2	5.0	mΩ
R _{DS(ON)}	Drain-Source On-State Resistance ^②	V _{GS} =4.5V, I _D =15A	--	5.2	7.0	mΩ
Dynamic Electrical Characteristics @ T_c = 25°C (unless otherwise stated)						
C _{iss}	Input Capacitance	V _{DS} =20V, V _{GS} =0V, f=1MHz	--	4285	--	pF
C _{oss}	Output Capacitance		--	280	--	pF
C _{rss}	Reverse Transfer Capacitance		--	145	--	pF
Q _g	Total Gate Charge	V _{DS} =20V, I _D =10A, V _{GS} =10V	--	68	--	nC
Q _{gs}	Gate-Source Charge		--	13	--	nC
Q _{gd}	Gate-Drain Charge		--	10	--	nC
Switching Characteristics						
t _{d(on)}	Turn-on Delay Time	V _{DD} =20V, I _D =10A, R _G =6.8Ω, V _{GS} =10V	--	13	--	nS
t _r	Turn-on Rise Time		--	16	--	nS
t _{d(off)}	Turn-Off Delay Time		--	55	--	nS
t _f	Turn-Off Fall Time		--	28	--	nS
Source- Drain Diode Characteristics @ T_c = 25°C (unless otherwise stated)						
V _{SD}	Forward on voltage	I _{SD} =50A, V _{GS} =0V	--	0.89	1.2	V
t _{rr}	Reverse Recovery Time	T _j =25°C, I _{sd} =10A, V _{GS} =0V di/dt=100A/μs	--	22	--	nS
Q _{rr}	Reverse Recovery Charge		--	48	--	nC

NOTE:

- ① Repetitive rating; pulse width limited by max. junction temperature.
- ② Pulse width ≤ 300μs; duty cycles ≤ 2%
- ③ Limited by T_{Jmax}, starting T_J = 25°C, L = 0.5mH, R_G = 25Ω, I_{AS} = 15A, V_{GS} = 10V. Part not recommended for use above this value.

Typical Characteristics

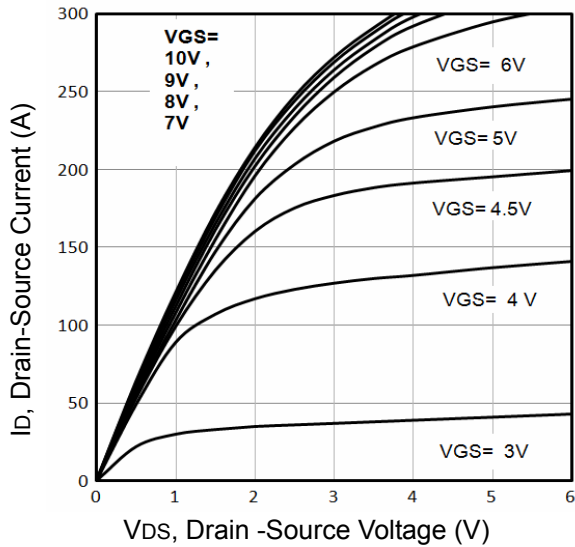

Fig1. Typical Output Characteristics

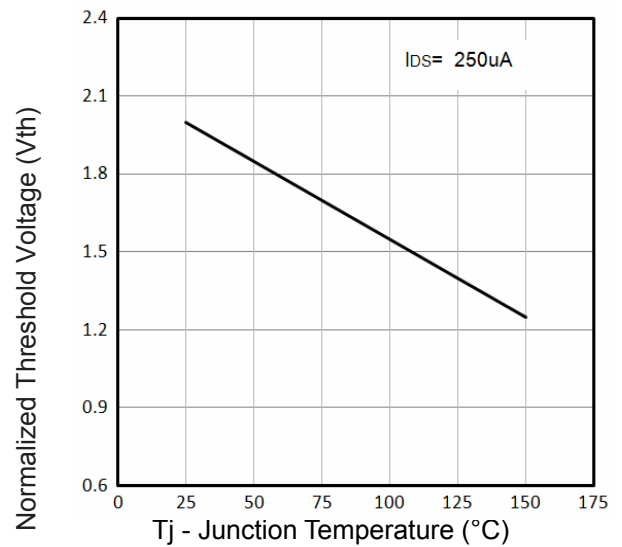

Fig2. Normalized Threshold Voltage Vs. Temperature

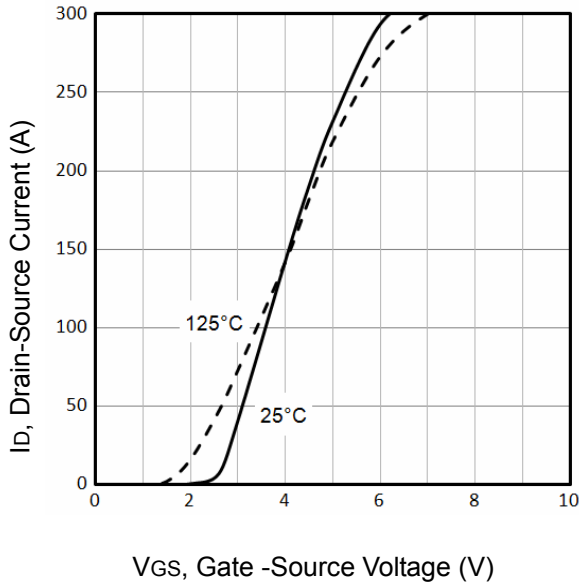

Fig3. Typical Transfer Characteristics

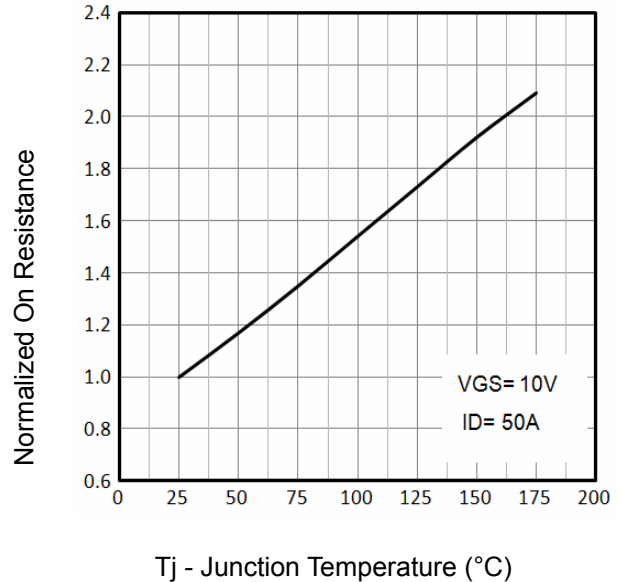

Fig4. Normalized On-Resistance Vs. Temperature

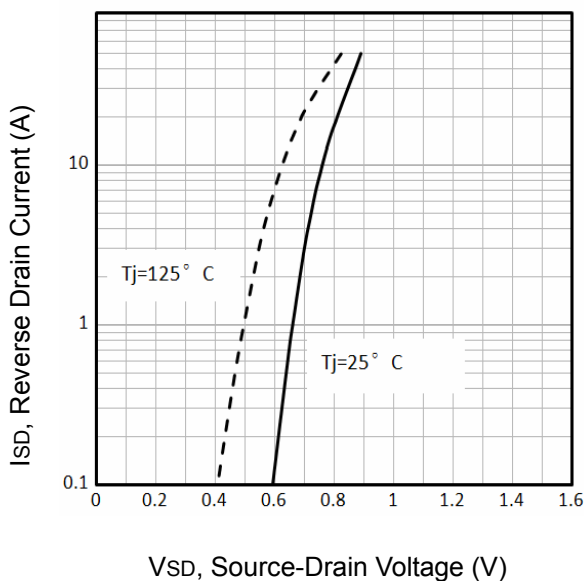

Fig5. Typical Source-Drain Diode Forward Voltage

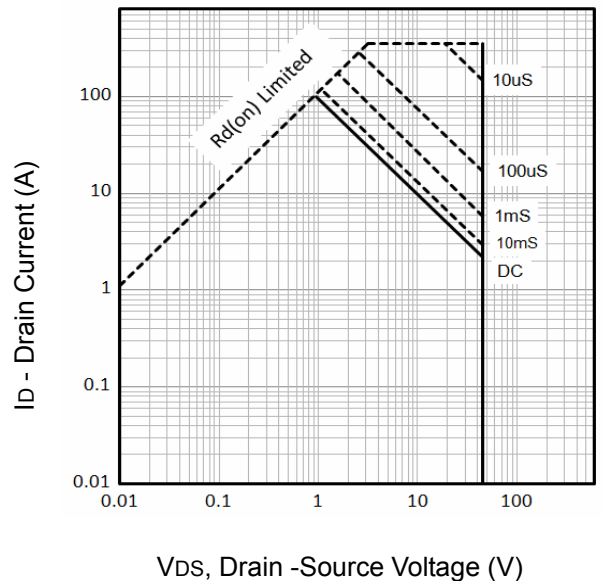

Fig6. Maximum Safe Operating Area

Typical Characteristics

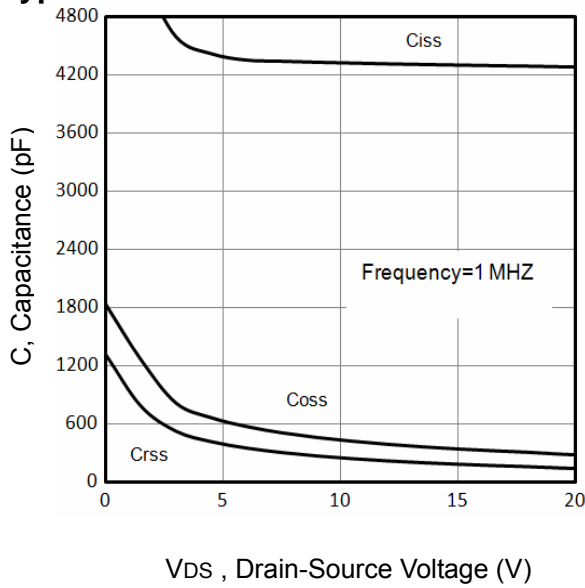

Fig7. Typical Capacitance Vs. Drain-Source Voltage

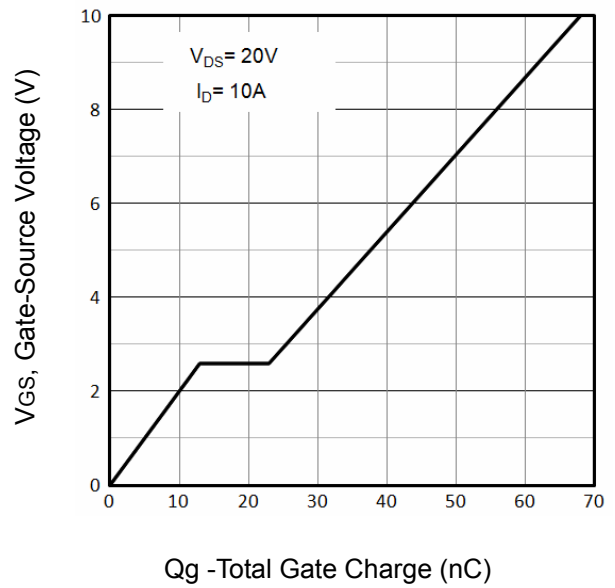

Fig8. Typical Gate Charge Vs. Gate-Source

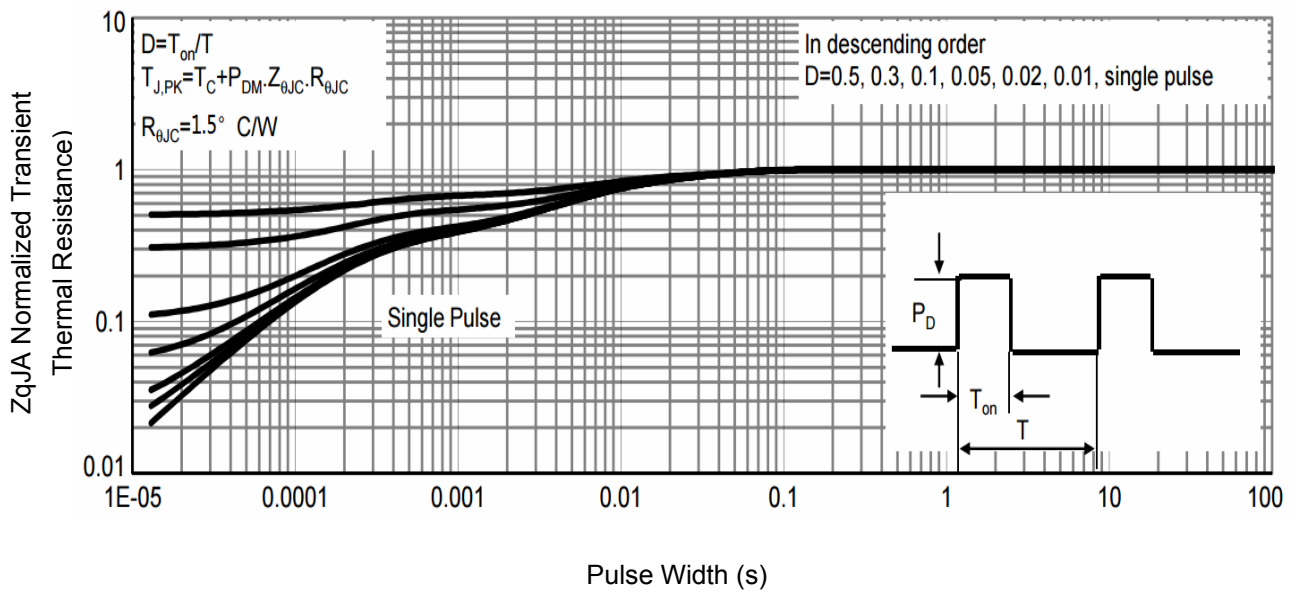

Fig9. Normalized Maximum Transient Thermal Impedance

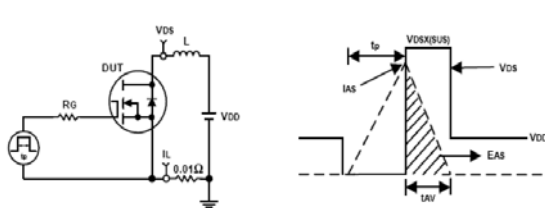

Fig10. Unclamped Inductive Test Circuit and waveforms

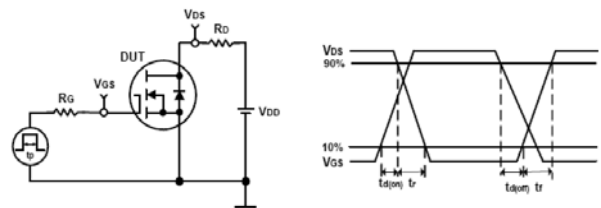
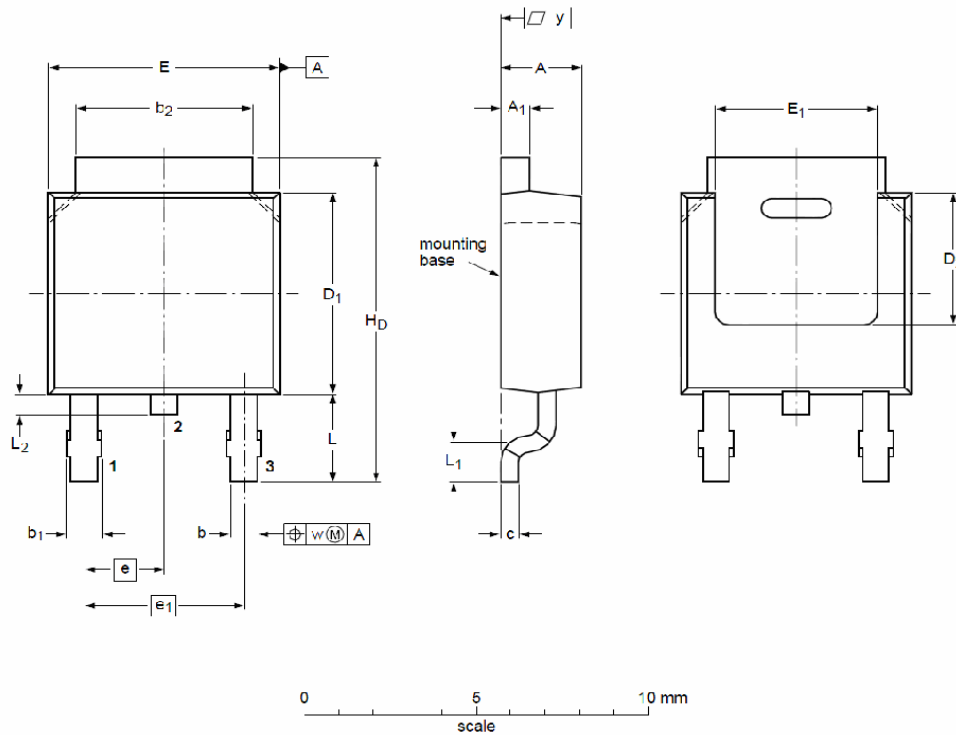

Fig11. Switching Time Test Circuit and waveforms

TO-252 Package Outline



DIMENSIONS (unit : mm)

Symbol	Min	Typ	Max	Symbol	Min	Typ	Max
A	2.22	2.30	2.38	A ₁	0.46	0.58	0.93
b	0.71	0.79	0.89	b ₁	0.90	0.98	1.10
b ₂	5.00	5.30	5.46	c	0.20	0.40	0.56
D ₁	5.98	6.05	6.22	D ₂	--	4.00	--
E	6.47	6.60	6.73	E ₁	5.10	5.28	5.45
e	--	2.28	--	e ₁	--	4.57	--
H _D	9.60	10.08	10.40	L	2.75	2.95	3.05
L ₁	--	0.50	--	L ₂	0.80	0.90	1.10
w	--	0.20	--	y	0.20	--	--

Customer Service

Sales and Service:

sales@vgsemi.com

Vanguard Semiconductor CO., LTD

TEL: (86-755) -26902410

FAX: (86-755) -26907027

WEB: www.vgsemi.com