

Features

- N-Channel, 5V Logic Level Control
- Enhancement mode
- Very low on-resistance $R_{DS(on)}$ @ $V_{GS}=4.5V$
- 100% Avalanche Tested
- Pb-free lead plating; RoHS compliant



Part ID	Package Type	Marking	Tape and reel information
VS4604ATD	TO-263	4604ATD	1000pcs/Reel

V_{DS}	40	V
$R_{DS(on),TYP} @ V_{GS}=10V$	2.6	m Ω
$R_{DS(on),TYP} @ V_{GS}=4.5V$	3.7	m Ω
I_D	150	A

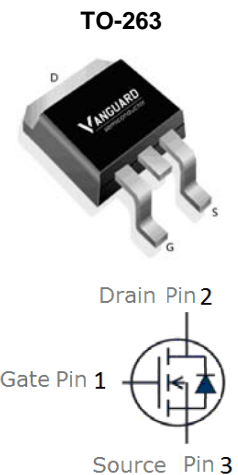

Maximum ratings, at $T_j=25^\circ\text{C}$, unless otherwise specified

Symbol	Parameter	Rating	Unit
$V_{(BR)DSS}$	Drain-Source breakdown voltage	40	V
I_S	Diode continuous forward current	$T_C=25^\circ\text{C}$ 150	A
I_D	Continuous drain current @ $V_{GS}=10V$	$T_C=25^\circ\text{C}$ 150	A
		$T_C=100^\circ\text{C}$ 106	A
I_{DM}	Pulse drain current tested ①	$T_C=25^\circ\text{C}$ 600	A
EAS	Avalanche energy, single pulsed ②	406	mJ
P_D	Maximum power dissipation	$T_C=25^\circ\text{C}$ 115	W
V_{GS}	Gate-Source voltage	± 20	V
$T_{STG} T_J$	Storage and operating temperature range	-55 to 175	$^\circ\text{C}$

Thermal Characteristics

Symbol	Parameter	Typical	Unit
$R_{\theta JC}$	Thermal Resistance-Junction to Case	1.3	$^\circ\text{C/W}$
$R_{\theta JA}$	Thermal Resistance-Junction to Ambient	62.5	$^\circ\text{C/W}$

Typical Characteristics

Symbol	Parameter	Condition	Min.	Typ.	Max.	Unit
Static Electrical Characteristics @ T_j = 25°C (unless otherwise stated)						
V _{(BR)DSS}	Drain-Source Breakdown Voltage	V _{GS} =0V, I _D =250μA	40	--	--	V
I _{DSS}	Zero Gate Voltage Drain Current	V _{DS} =40V, V _{GS} =0V	--	--	1	μA
	Zero Gate Voltage Drain Current(T _j =125°C)	V _{DS} =40V, V _{GS} =0V	--	--	100	μA
I _{GSS}	Gate-Body Leakage Current	V _{GS} =±20V, V _{DS} =0V	--	--	±100	nA
V _{GS(TH)}	Gate Threshold Voltage	V _{DS} =V _{GS} , I _D =250μA	1.0	1.7	2.5	V
R _{DS(ON)}	Drain-Source On-State Resistance ^③	V _{GS} =10V, I _D =40A	--	2.6	4	mΩ
R _{DS(ON)}	Drain-Source On-State Resistance ^③	V _{GS} =4.5V, I _D =20A	--	3.7	5	mΩ
Dynamic Electrical Characteristics @ T_j = 25°C (unless otherwise stated)						
C _{iss}	Input Capacitance	V _{DS} =20V, V _{GS} =0V, f=1MHz	4300	5140	5900	pF
C _{oss}	Output Capacitance		300	445	600	pF
C _{rss}	Reverse Transfer Capacitance		280	390	500	pF
R _g	Gate Resistance	f=1MHz		2		Ω
Q _g	Total Gate Charge	V _{DS} =20V, I _D =40A, V _{GS} =10V	--	83	--	nC
Q _{gs}	Gate-Source Charge		--	16	--	nC
Q _{gd}	Gate-Drain Charge		--	17	--	nC
Switching Characteristics						
t _{d(on)}	Turn-on Delay Time	V _{DD} =20V, I _D =40A, R _G =3Ω, V _{GS} =10V	--	15.7	--	nS
t _r	Turn-on Rise Time		--	6.5	--	nS
t _{d(off)}	Turn-Off Delay Time		--	56	--	nS
t _f	Turn-Off Fall Time		--	12	--	nS
Source- Drain Diode Characteristics @ T_j = 25°C (unless otherwise stated)						
V _{SD}	Forward on voltage	I _{SD} =40A, V _{GS} =0V	--	0.8	1.2	V
t _{rr}	Reverse Recovery Time	T _j =25°C, I _{sd} =40A, V _{GS} =0V	--	18	--	nS
Q _{rr}	Reverse Recovery Charge	di/dt=500A/μs		40		nC

NOTE:

- ① Repetitive rating; pulse width limited by max. junction temperature.
- ② Limited by T_{Jmax}, starting T_J = 25°C, L = 0.5mH, R_G = 25Ω, I_{AS} = 25A, V_{GS} = 10V. Part not recommended for use above this value
- ③ Pulse width ≤ 300μs; duty cycles ≤ 2%.

Typical Characteristics

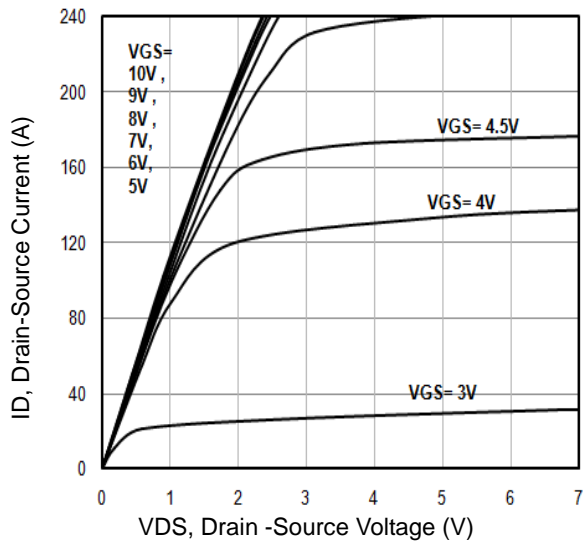

Fig1. Typical Output Characteristics

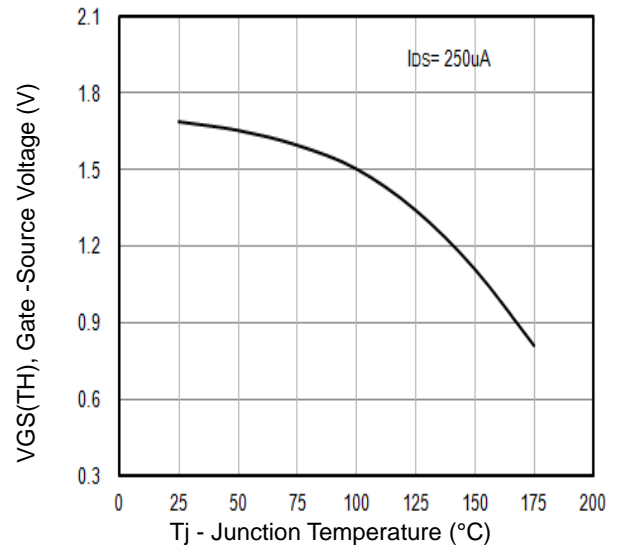

Fig2. $V_{GS(TH)}$ Gate -Source Voltage Vs. T_j

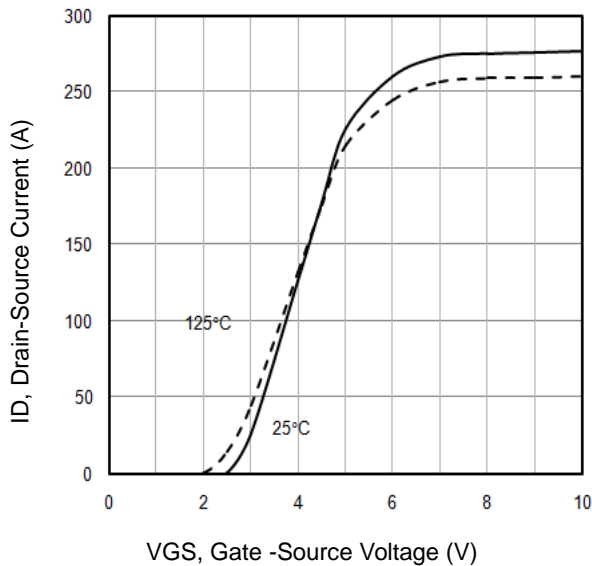

Fig3. Typical Transfer Characteristics

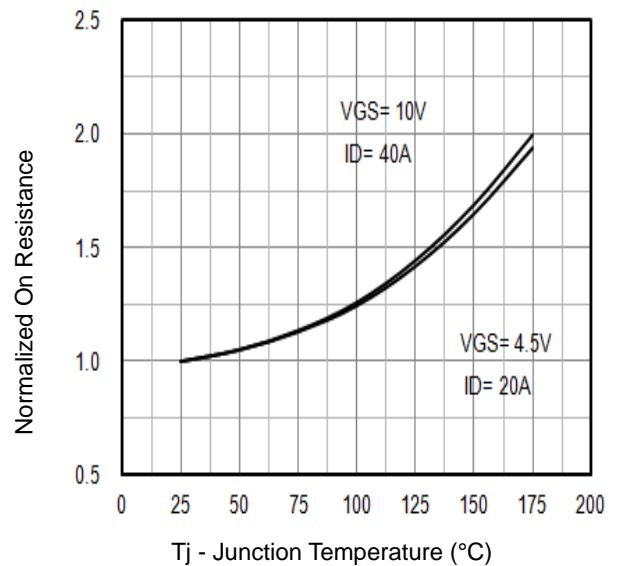

Fig4. Normalized On-Resistance Vs. Temperature

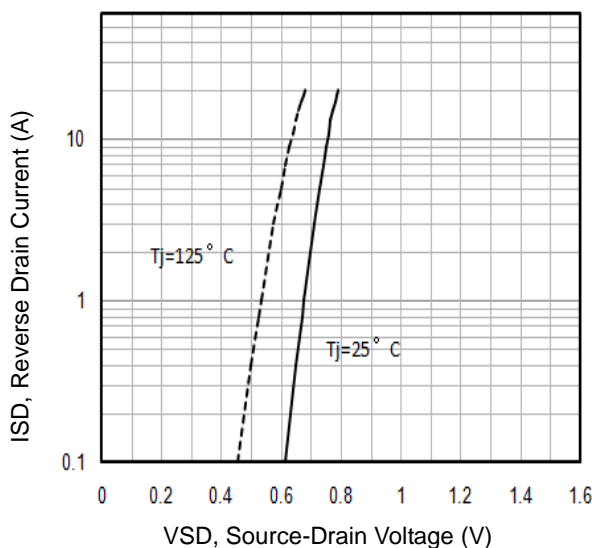

Fig5. Typical Source-Drain Diode Forward Voltage

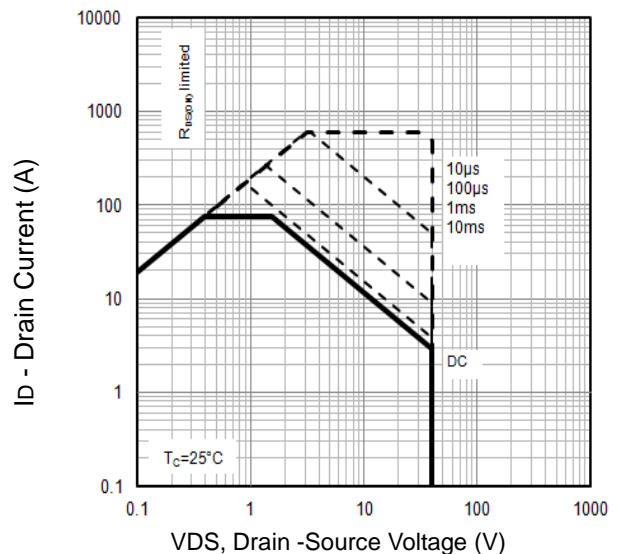

Fig6. Maximum Safe Operating Area

Typical Characteristics

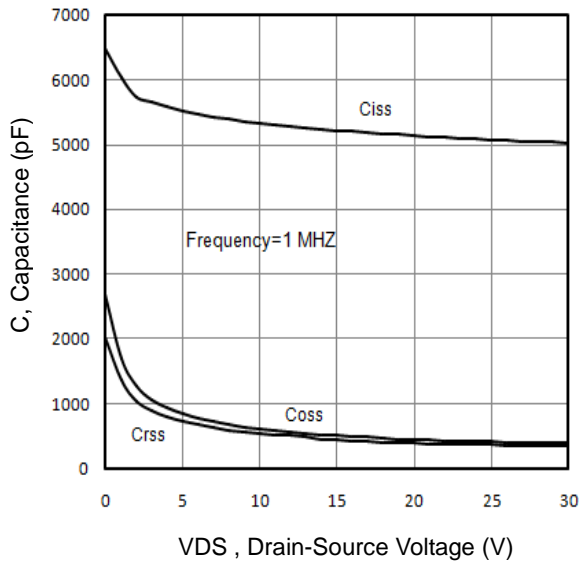

Fig7. Typical Capacitance Vs.Drain-Source Voltage

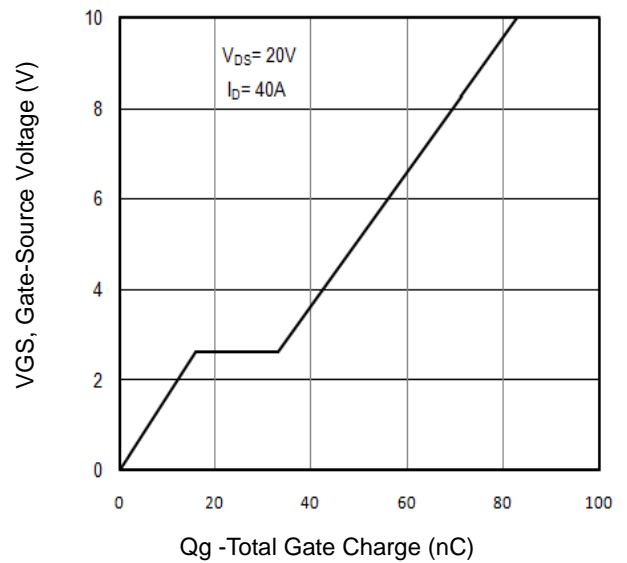

Fig8. Typical Gate Charge Vs.Gate-Source Voltage

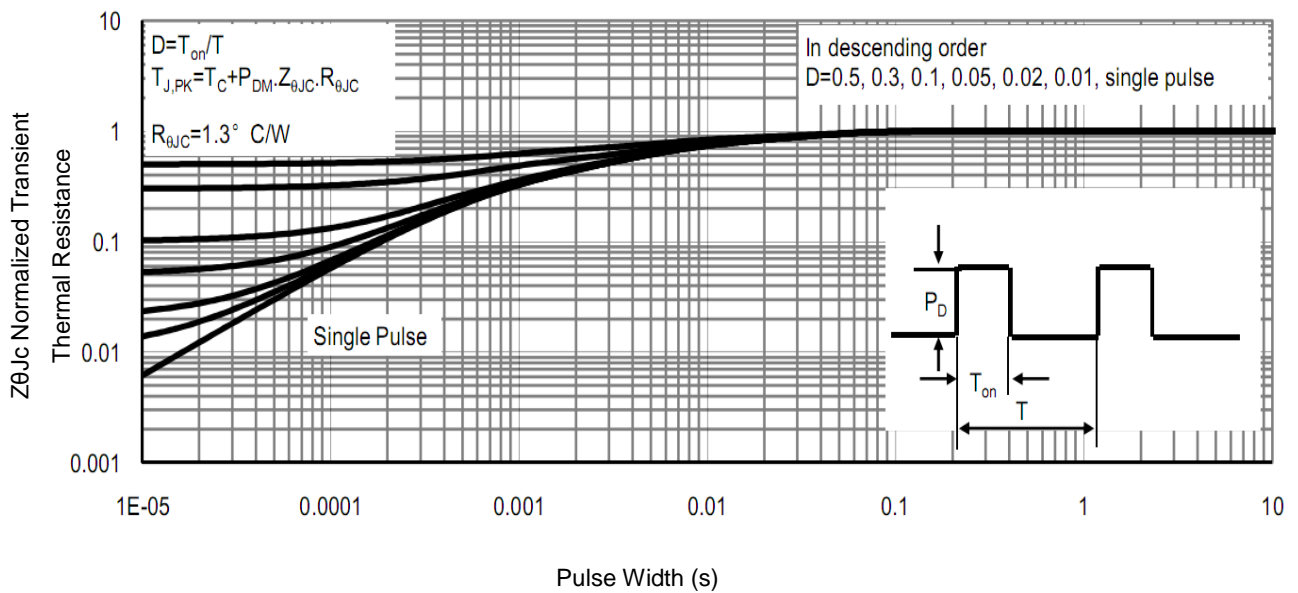

Fig9 . Normalized Maximum Transient Thermal Impedance

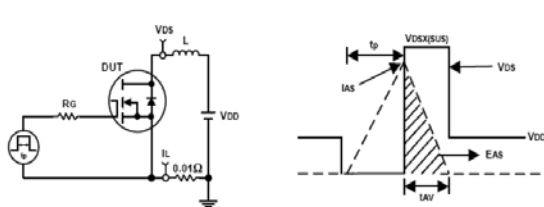

Fig10. Unclamped Inductive Test Circuit and waveforms

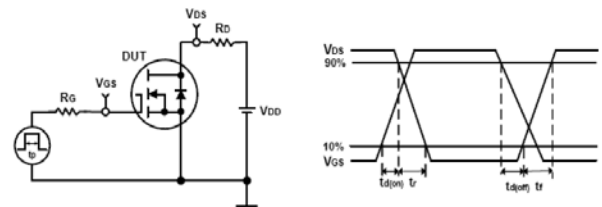
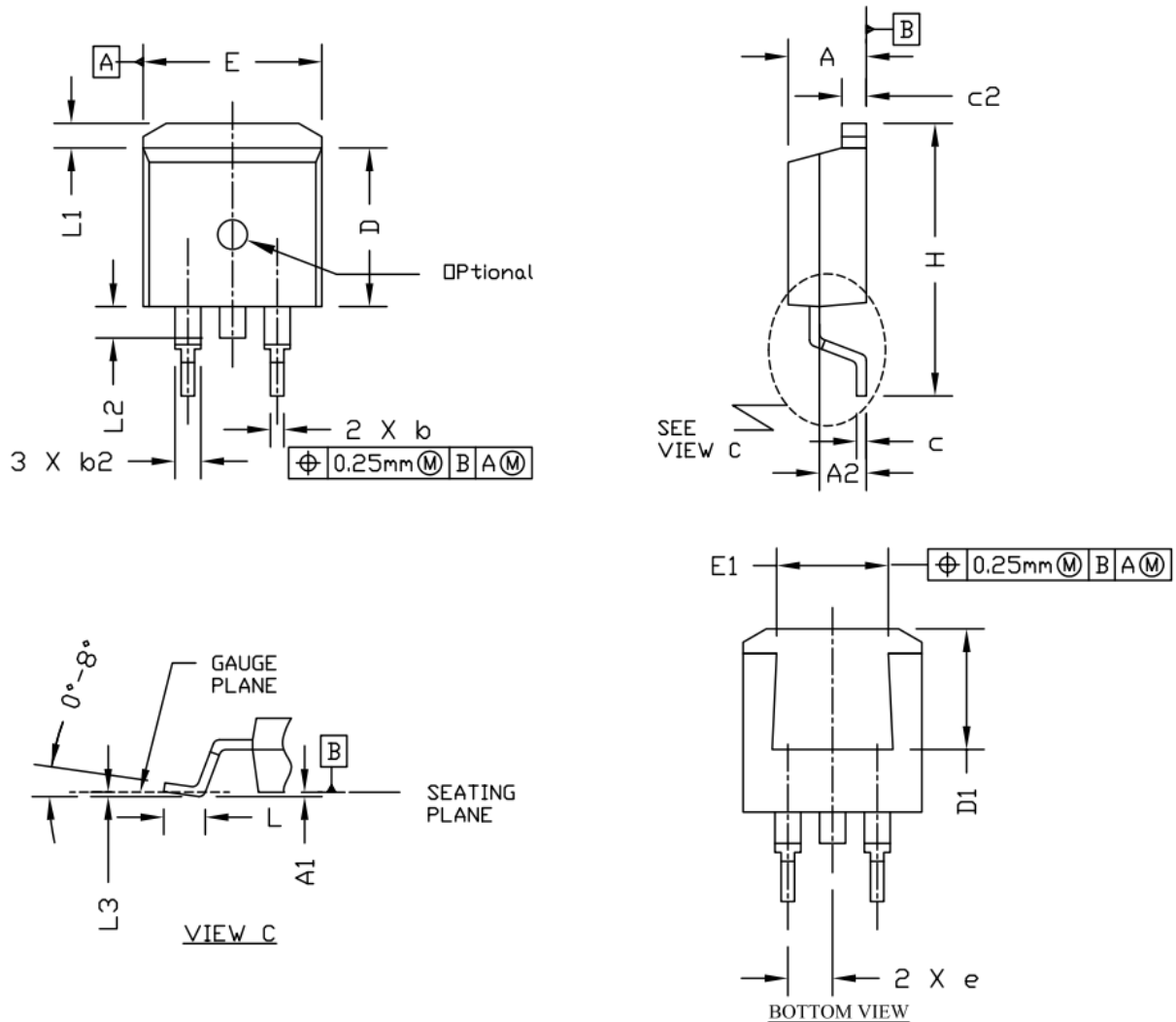

Fig11. Switching Time Test Circuit and waveforms

TO-263 Package Outline Data



Symbol	Dimensions (unit: mm)		
	Min	Typ	Max
A	4.400	4.570	4.700
A1	0.000	0.100	0.200
A2	2.300	2.400	2.500
b	0.700	0.800	0.900
b2	1.200	1.270	1.360
c	0.381	0.500	0.737
c2	1.220	1.300	1.350
D	8.600	9.200	9.300
D1	6.860		
e	2.540 BSC		
E	9.780	9.880	10.260
E1	6.225		
H	14.700	15.100	15.500
L	2.000	2.550	2.750
L1	1.000	1.200	1.400
L2	1.300	1.600	1.700
L3	0.255 BSC		

Notes:

1. Refer to JEDEC TO-263 variation AB
2. Dimension "D" & "E" do NOT include mold flash, mold flash shall not exceed 0.127mm per side.

Customer Service

Sales and Service:

sales@vgsemi.com

Vanguard Semiconductor CO., LTD

TEL: (86-755) -26902410

FAX: (86-755) -26907027

WEB: www.vgsemi.com