

IQ2200 Network Processor

**SPECIFICATIONS:****Performance:**

- ▶ 400 MHz, 32-bit RISC processors
- ▶ Single 25 MHz crystal drives all clocks

I/O:

- ▶ 32-bit CSIX-L1 Interface up to 166 MHz
- ▶ Gigabit Ethernet MACs on Ports A, B, full-duplex
- ▶ FOCUS16: 1.6Gbps@16-bit, full-duplex
- ▶ FOCUS32: 3.2Gbps@32-bit, full-duplex
- ▶ MIPS SYSAD Bus: 100 MHz, 32/64-bit
- ▶ 32-bit Asynchronous Host Interface
- ▶ Rambus memory controller supports 800 MHz and 1066 MHz Direct RDRAM and SO-RIMM options

Electrical:

- ▶ 1.2V core
- ▶ 1.8V Rambus RAC
- ▶ 3.3V I/O
- ▶ 4W (typical)
- ▶ 6W (max)

Operating:

- ▶ 0° - 70° Celsius

Mechanical:

- ▶ 673 pin BGA, same as used by the IQ2000 family

HIGHLIGHTS:

- ▶ Fully firmware-compatible and pin-compatible with IQ2000
- ▶ Double the IQ2000 performance at half the power with four, fully programmable, multi-context packet processing engines
- ▶ Flexible, High Bandwidth I/O Interface Capability
- ▶ High Performance, Patented Internal Architecture (100Gb/s)
- ▶ CSIX-L1 Fabric Interface
- ▶ Control Plane Processor Independence (Native support for MIPS, PowerPC, and other RISC implementations)
- ▶ Specialized Co-Processors for Lookup, Order Management, Multicast Support, DMA Management, and Context Management
- ▶ Optimized Instruction Set for Network Operations
- ▶ Per Flow Queuing Support for up to a half million flows.
- ▶ Hardware Support for Quality (QoS) of Service Building Blocks
- ▶ Comprehensive Development Tools
- ▶ Next Generation Service Acceleration: MPLS, DiffServ, IPSec, Provisioning, AAA, Server Load Balancing, & More

IDEAL APPLICATIONS:**High port density applications**

- ▶ OC-3 to 2xOC12 ATM/PoS PHY
- ▶ 10/100/1000 Ethernet
- ▶ Channelized OC-3 to OC-12
- ▶ DS0 - DS3 Aggregation

Standalone or Modular Systems

- ▶ Intelligent Edge Devices
- ▶ Switches and Routers
- ▶ Packet/Voice Gateways
- ▶ Service Creation Systems
- ▶ Security Systems

IQ2200 Network Processor

IP BASED SERVICE-ENABLED AGGREGATION PLATFORM:



The Intelligent Edge of the PDN Transport Core must provide both data aggregation and extensive IP Services. Although these two elements conceptually work closely together, today they are performed in entirely different products (aggregation and service delivery).

Link aggregation products take data that is transported over low speed links (or potentially multiple low speed links) and assemble this data into IP Packets. This is a job of varying degrees of difficulty, depending on link type and aggregation methodology employed.

Once aggregation has occurred, services are applied on a variety of basis (flows within aggregated channels, micro-flows within flows, the channel itself, etc.). In this area, services are defined as "value-added operations" performed on a packet (tagging for MPLS, classification for DiffServ, policy enforcement, and other sophisticated services).

This design concept is unique because it provides the basis for collapsing two physically different components (with different architectures, different management facilities, and different provisioning facilities) into a single, highly integrated platform.

PLATFORM BLOCK DIAGRAM:

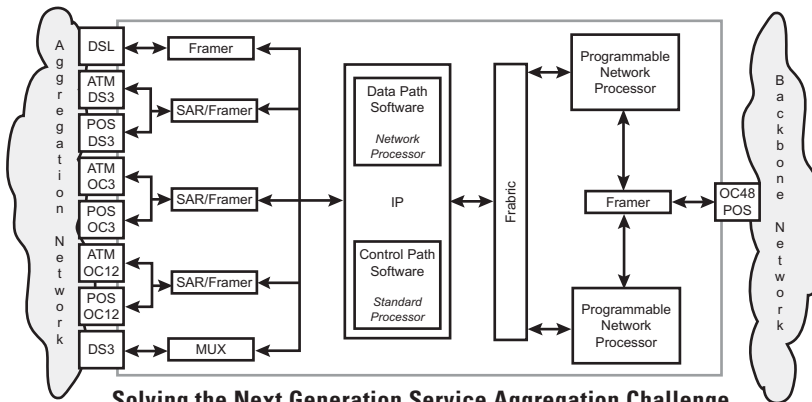

**Solving the Next Generation Service Aggregation Challenge...
An Example Use of the IQ2200 Family**

WHAT TO LOOK FOR:

- ▶ Exceptional Processing Capability
- ▶ Scalable Processing Architecture
- ▶ Flexibility & Programmability
- ▶ Optimized use of Co-processors and High-Performance Memory
- ▶ "Headroom" for Emerging Services
- ▶ Variety of OPEN Interconnect Mechanisms
- ▶ Control Plane Processor Independence
- ▶ Robust Software Development Environment

THE IQ2200 DELIVERS:

- ▶ Complex Multi-Protocol Routing
- ▶ Quality of Service
- ▶ Classification
- ▶ Filtering
- ▶ Stateful Inspection
- ▶ Traffic Policing
- ▶ Traffic Grooming/Shaping
- ▶ Multicast/Stream Management
- ▶ Address Translation

Your Partner for Success.

For more information on Vitesse Products visit the Vitesse web site at www.vitesse.com or contact Vitesse Sales at (800) VITESSE or sales@vitesse.com

VITESSE

741 Calle Plano
Camarillo, CA 93012
Tel: 805.388.3700
Fax: 805.388.7565
www.vitesse.com

IQ2200 Family of Network Processors

PERFORMANCE AND FLEXIBILITY:



The IQ2200™ Family of Network Processors extends the successful Vitesse IQ2000 network processor family, doubling packet processing performance and improving switch fabric connectivity while maintaining firmware and pinout compatibility for rapid application. The IQ2200 family is designed to deliver flexible, high-performance, deep-packet processing solutions at speeds ranging from DS0 to OC-48.

Applications for the IQ2200 family include complex multi-protocol routing, classification, filtering, stateful inspection, encryption, policing/policy enforcement, traffic grooming/shaping, multicast/stream management, network address translation, and other demanding packet processing operations.

Rapid system time-to-market can be dramatically improved when the IQ2200 NPU is coupled with other Vitesse solutions including Physical Layer processing devices, Traffic Managers, and High Speed Switching Fabrics.

CHANGE IS CONSTANT...

A fundamental shift is occurring in the network-hardware-manufacturing marketplace as demands for very high-speed, service-enabled products eclipse those for more traditional layer 2/3 routing and switching offerings. The combination of hardware acceleration needs, direct support for IP services/features, and demands for longer product life-cycles with reduced time to market, has given birth to the Programmable Network Processor industry. Hardware vendors are in need of an “adjunct” processing solution that addresses both current and future challenges in network evolution;

successfully meeting these challenges through standard products is key to maintaining a competitive edge. The IQ2000 and IQ2200 families enable innovation by providing a high performance, flexible solution that meets today’s challenges in networking and communication technology without the time-to-market constraints, fixed-function limitations, and short product life cycles associated with ASIC technology.

SERVICE ENABLEMENT:

Supports scalable deployment of value-added IP services (from DS-0 to OC-48)

- ▶ MPLS ▶ IPsec
- ▶ DiffServ ▶ NAT

Embedded Hardware QoS Building Blocks

- ▶ RIO ▶ RED
- ▶ WRED ▶ RR
- ▶ WRR ▶ WFQ

OPEN ARCHITECTURE:

Standards Based Compliance

Variety of Third Party Interfaces Supported

Variety of Third Party Application Specific Processors Supported (Policy, Security, Encryption)

Variety of Fabrics Supported through third party ASICs and FPGAs

The IQ2200 Family Delivers High Performance Network Processing

Exceptional Processing Capability <ul style="list-style-type: none"> • 4 High Performance, load balanced CPUs • Supports high-speed Interfaces up to OC-48 • Packet order maintained throughout 	Scaleable Architecture <ul style="list-style-type: none"> • Modular Architecture provides for scaleable growth
Flexibility/Programmability <ul style="list-style-type: none"> • A totally open, programmable solution, for providing next generation services • Uni-processor programming model 	Co-Processors <ul style="list-style-type: none"> • Embedded function specific Co-processors for QoS, Data Movement, Classification, Lookup, and other functions
Headroom <ul style="list-style-type: none"> • More Headroom than any NPU vendor • Margin for future features through software upgrade 	Open Interconnect <ul style="list-style-type: none"> • Open Interconnect via Partner Devices (DS-0 to OC-48) and Fabrics • CSIX-L1 Fabric Interface
Control Plane Processor <ul style="list-style-type: none"> • Match the Standard Processor features/price to meet your requirements 	Robust Software Development <ul style="list-style-type: none"> • Comprehensive Hardware/Software Developers Workbench

IQ2200 ARCHITECTURE:

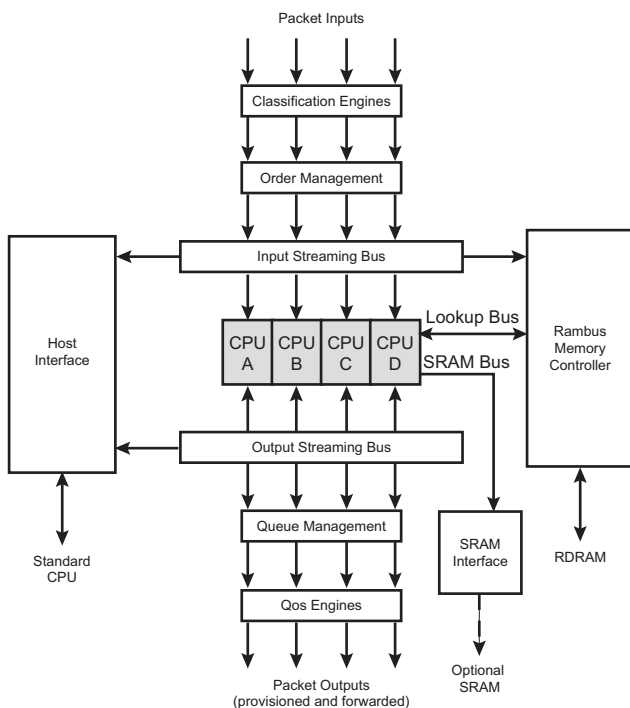

ROBUST DEVELOPMENT ENVIRONMENT:

- Comprehensive Developer Workbench
- High-performance Debug Tools
- Powerful Simulation and Test Environment
- Performance Optimization Toolbox
- Network Software Library (example code for routing, bridging, lookup functions, tagging, marking/re-marking, queuing, etc.)
- Intelligent Network APIs
- Optimized Network-Specific Functions

PERFORMANCE INVESTMENT PROTECTION:

- Programmability enables functional evolution with the emergence or revision of standards
- Connectivity between NPUs delivers linear scaling of service delivery and performance, thus enabling terabit class system development
- Architecture provides "Maximum Headroom" for emerging IP service applications
- Architecture provides backward compatibility from generation to generation
- RISC development environment facilitates code portability, reuse and software investment protection Control Plane Processor Independence

VSC2232:

The VSC2232 Network Processor is targeted at the Optical Network Intelligent Edge. With the CSIX or FOCUS32 interfaces, the VSC2232 supports connections to a wide variety of fabrics and optical network interfaces.

VSC2202:

The VSC2202 Network processor is a Gigabit Ethernet enabled device well suited for server load balancing and service-enabled Ethernet aggregation. With two Gigabit Ethernet MACs and either one CSIX, or one FOCUS32 or two FOCUS16 interface(s), a variety of fabric or interface connections are possible.

VSC2200:

The VSC2200 member of the IQ2200 family is available with either four FOCUS16 interfaces or two FOCUS16 interfaces and one CSIX or one FOCUS32 interface. The IQ2200 VSC2200 is ideally suited for service-enabled aggregation platforms providing aggregation at rates from DS0 to OC12.

IQ2200 FAMILY BLOCK DIAGRAM:

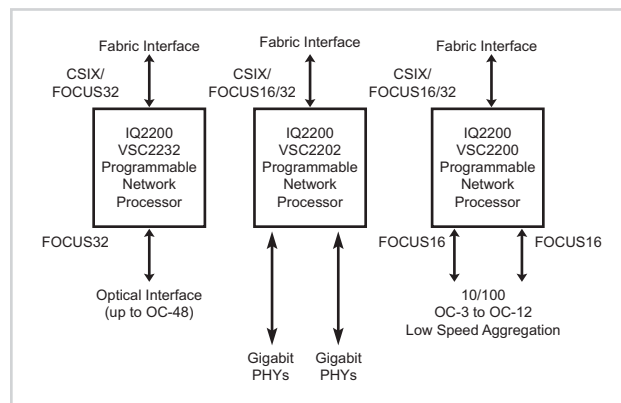

IQ2200 Feature and Part Selection Guide

IQ2200 Part No.			FOCUS Port Configuration			
VSC2200	VSC2201	VSC2232	FOCUS A	FOCAS B	FOCUS C	FOCUS D
•	•	•	FOCAS 16	FOCAS 16	FOCAS 16	FOCAS 16
•	•	•	FOCUS 16	FOCAS 16	FOCUS 32	
-	•	•	GigaMAC	FOCAS 16	FOCAS 16	FOCAS 16
-	•	•	GigaMAC	FOCAS 16	FOCUS 32	
-	•	•	GigaMAC	GigaMAC	FOCAS 16	FOCAS 16
-	•	•	GigaMAC	GigaMAC	FOCUS 32	
-	-	•	FOCUS 32		FOCAS 16	FOCAS 16
-	-	•	FOCUS 32		FOCUS 32	

• = featured configuration - = featured not available

* FOCUS C & FOCUS D ports also serve as the CSIX-L1 Interface