

VSC5529

www.DataSheet4U.com

VITESSE

9.9 Gb/s – 12.5 Gb/s NRZ LiNbO₃ Modulator Driver

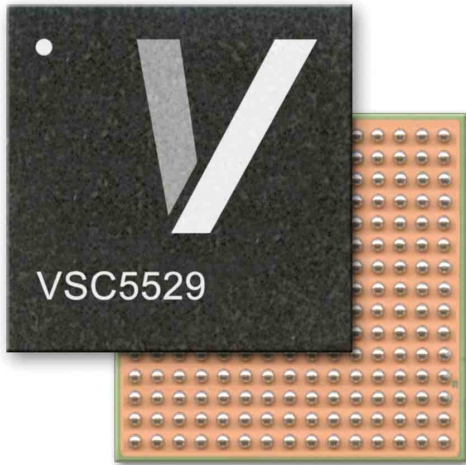

APPLICATIONS:

- ▶ Metro and Long Haul LiNbO₃ NRZ Applications
- ▶ Sonet OC-192 / SDH STM-64 Transmitters
- ▶ G.709, G.975, GbE, & Proprietary FEC Systems
- ▶ Line Cards
- ▶ Transponder Modules

FEATURES:

- ▶ Wide Output Dynamic Range
- ▶ Ultra-small 16mm x 16mm BGA Package
- ▶ High Input Sensitivity
- ▶ Low Jitter
- ▶ Precision Output Amplitude Monitor Circuitry
- ▶ Single-ended or Differential Input
- ▶ Precise Duty Cycle Control

BENEFITS:

- ▶ Surface Mount Package
- ▶ Superior Electrical / Optical Eye Quality
- ▶ Easy Application of Closed-loop Amplitude Control
- ▶ Differential Input Accommodates Inverting or Non-inverting Implementations
- ▶ Input Limiting Amplifier for Consistent Output Quality

SPECIFICATIONS:

- ▶ 9.9 – 12.5 Gb/s NRZ Datarates
- ▶ 250mVp-p Single-ended Input Sensitivity
- ▶ 4.0 – 7.0Vp-p Output Amplitude (VSC5529-01)
- ▶ 3.0 – 6.0 Vp-p Output Amplitude (VSC5529-02)
- ▶ Typical S11 and S22 of -14dB
- ▶ Jitter 10pspp Typical
- ▶ Rail Ripple 5% Typical
- ▶ Output Amplitude Stability 1% Typical (under closed loop control)
- ▶ +8V / -5.2V Supplies
- ▶ 40-60% Duty Cycle Control Range

BLOCK DIAGRAM:

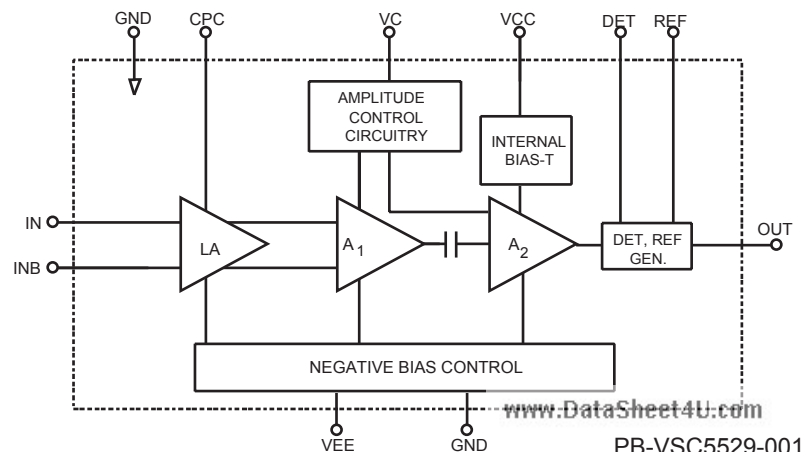

9.9 Gb/s – 12.5 Gb/s NRZ LiNbO₃ Modulator Driver

www.DataSheet4U.com

GENERAL DESCRIPTION:



The VSC5529 is a precision LiNbO₃ modulator driver. The input can be driven single-ended or differentially and features a single-ended sensitivity of 250mV. The VSC5529 provides a high quality single-ended output with amplitude control, precision amplitude monitoring circuitry, and eye crossing point control. The VSC5529 provides a digital limiting amplifier function to ensure high quality and very repeatable output signal characteristics even with less than optimal input signals. Key specifications include ultra-small form factor, fast rise/fall times, low output jitter, high voltage drive capability, high input sensitivity and low rail ripple. Furthermore, the VSC5529 amplitude control feature is specifically designed to provide consistent output shape and crossing point over the full range of control.

APPLICATION DIAGRAM:

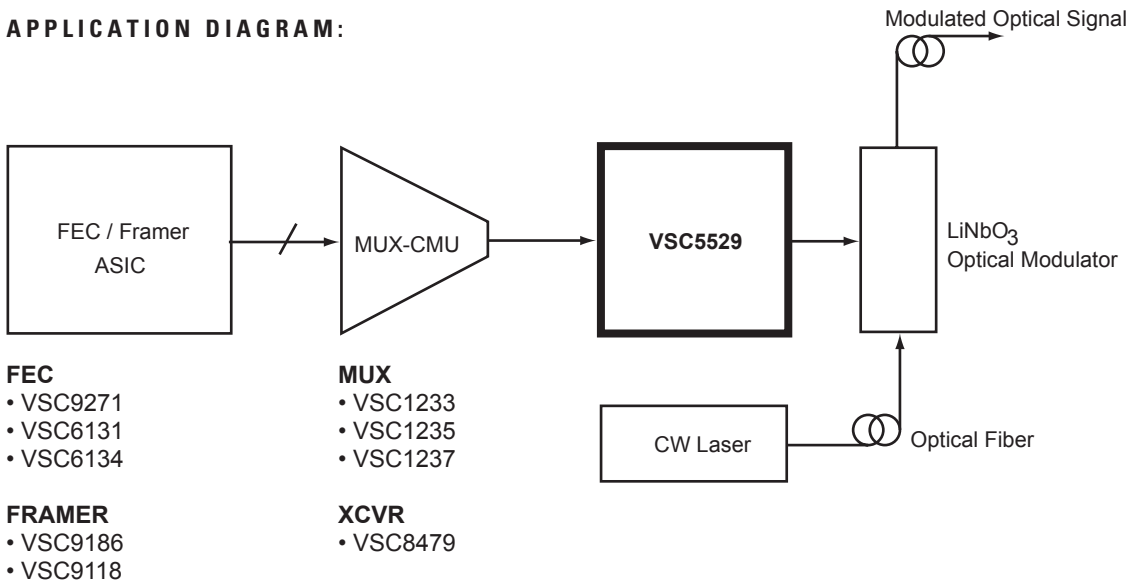

For more information on Vitesse Products visit the Vitesse web site at www.vitesse.com or contact Vitesse Sales at (800) VITESSE or send email to: sales@vitesse.com