

VSC7174

VITESSE

Quad Serial ATA Host Bus Adapter



SPECIFICATIONS:

- (37.5 MHz Reference Clock or Crystal
- (Optional 128KB Serial Flash ROM for Code Store
- (3.3V and 2.5V Supply, 2.0W (Typical)
- (256-pin, 17 mm PBGA Package

APPLICATIONS:

- (RAID-On-MotherBoard (ROMB) for High-End PCs and Servers
- (Standalone Serial ATA Host Bus Adapters
- (Network Attached Storage (NAS) Systems
- (RAID Protected Disk Arrays

FEATURES:

- (Four Serial ATA Channels at 1.5 Gb/s
- (Serial ATA 1.0 Compliant
- (Serial ATA II Queuing Specification Compliant
- (PCI-X 1.0a Compliant (64 bits wide at 66, 100 and 133 MHz)
- (PCI 2.2 Compliant (64 bits wide at 33 and 66 MHz)
- (Software-Compatible Master/Slave Mode
- (Parallel ATA Compatibility
- (Performance-Oriented Master/Master Mode
- (Plug-n-Play Support
- (Hot Swappable
- (Activity LED Drivers
- (Wide Swing Mode for Driving Backplanes
- (Spread-Spectrum Clock Generation
- (Integrated Link/Transport Layer From APT Technology, Inc.

VSC7174 BLOCK DIAGRAM:

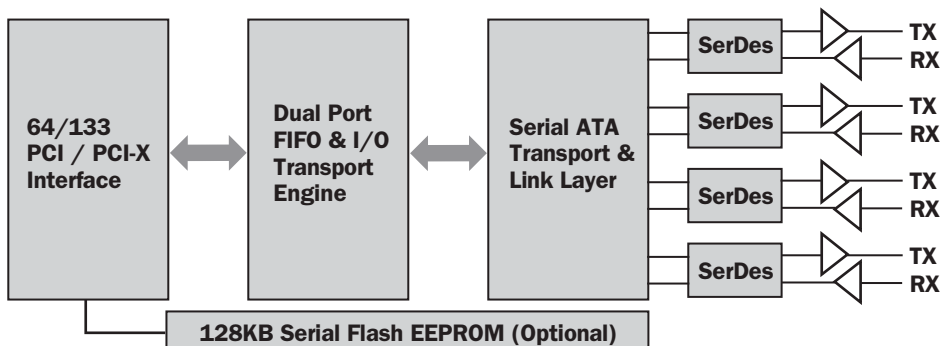

Quad Serial ATA Host Bus Adapter

GENERAL DESCRIPTION:



The VSC7174 is a single chip PCI/PCI-X to Serial ATA Host Bus Adapter that provides a robust, high-performance interface to Serial ATA Disk Drives, CD-ROMs, DVD-ROM's and Tape facilities. The device supports 8b/10b encoded data at Serial ATA v1.0 operating speeds of 1.5 Gb/s - equivalent to 150 MB/s of raw transfer performance; in addition, the VSC7174 can deliver burst transfer rates of up to 1064 MB/s.

The VSC7174 is driver compatible with existing operating systems supporting parallel ATA interfaces – providing an easy migration path for existing IDE customers.

The ease-of-use, flexibility, superior performance, and attractive price of the VSC7174 make it an ideal choice for your Serial ATA Host controller needs.

Contact your local Vitesse sales representative for future Serial ATA products.

APPLICATION EXAMPLE:

Fault Tolerant Disk Array Subsystem

The VSC7174 is finding widespread use in disk arrays where redundant embedded NAS Heads and RAID Controllers use multiple VSC7174's to connect to Serial ATA drives over high speed backplanes at 1.5 Gb/s.

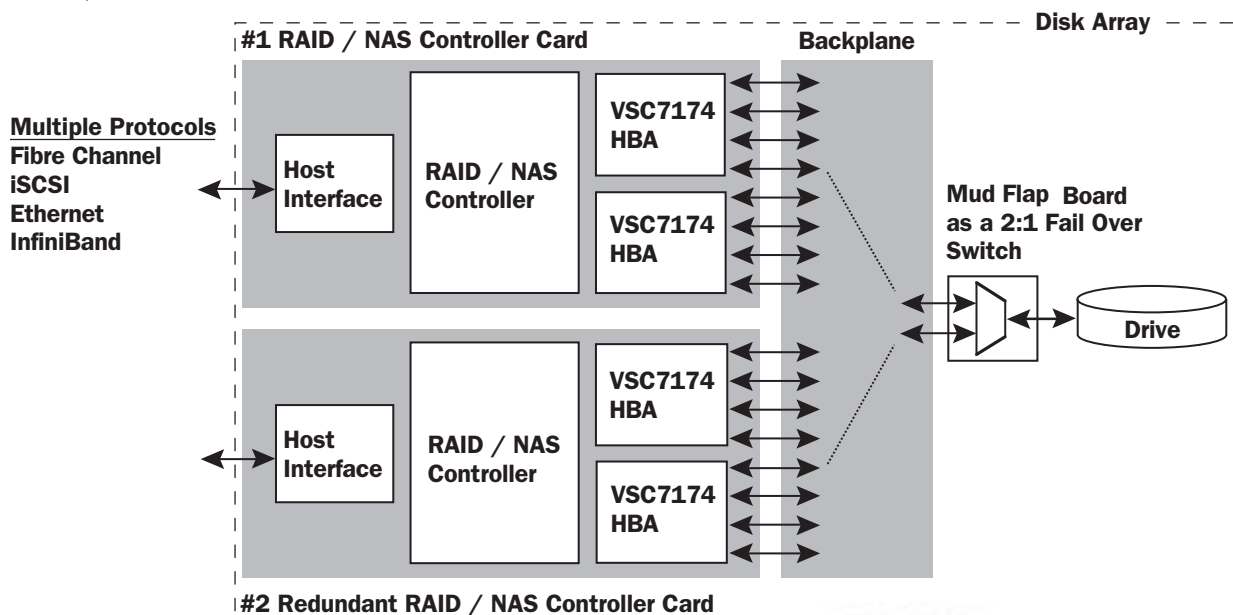

For more information on Vitesse Products visit the Vitesse web site at www.vitesse.com or contact Vitesse Sales at (800) VITESSE or send email to: sales@vitesse.com

VITESSE

741 Calle Plano
Camarillo, CA 93012, USA

Tel: +1 805.388.3700
Fax: +1 805.387.9999
www.DataSheet4U.com
www.vitesse.com