

Preliminary Data Sheet VSC7902

SONET/SDH Transimpedance Amplifier

Features

- SDH/SONET 155 Mb/s Compatible
- Single 5V Power Supply
- Single Ended Output
- Low Noise
- Integrated AGC
- Accepts a Wide Variety of Optical Detectors
- Industrial Temperature Range (-40 to +85 °C)

General Description

The VSC7902 Transimpedance Amplifier provides a highly integrated solution for converting the current produced by a photodiode into a output voltage. The typical application of these devices is in a front-end receiver for a fiber-optic communication channel. The benefits of Vitesse Semiconductor's Gallium Arsenide H-GaAs process are fully utilized to provide very high bandwidth and low noise. Parts are available in die form.

The VSC7902 Transimpedance Amplifier is typically used with long-wavelength optical detectors. The amplifier includes an integrated AGC function to sense a wide range of input currents. AGC is accomplished by modifying the transimpedance of the amplifier. The AGC loop time constant can be changed using an off-chip capacitor.

VSC7902 Block Diagram

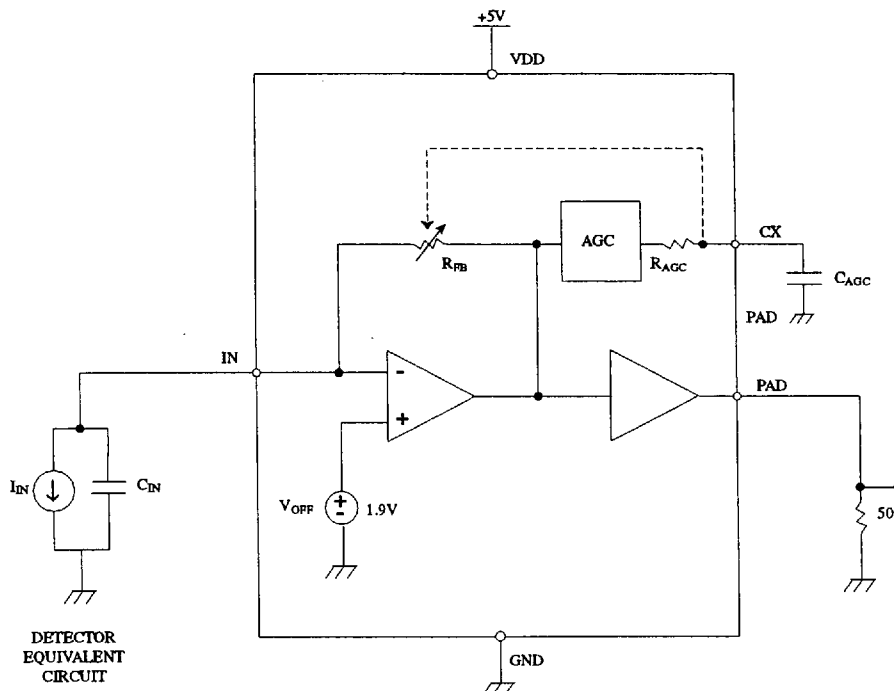

Table 1: Electrical Specifications

Symbol	Description	Min	Typ	Max	Units	Conditions
Z_{dc}	DC Transimpedance	10			K Ω	$R_L = \infty$
Z_{ac}	AC Transimpedance	5			K Ω	$R_L = 50\Omega$, $f = 150\text{MHz}$, $I_{in} = 4\mu\text{A}$
f_{3db}	Modulation Bandwidth	130			MHz	$R_L = 50\Omega$, $C_{in} = 0.8\text{pF}$, $I_{in} = 4\mu\text{A}$
I_{NOISE}	Input Noise Current Density		2		$\frac{\text{pA}}{\sqrt{\text{Hz}}}$	
I_{max}	Max. Input Current			2	mA	
I_{agc}	AGC Threshold Current		20		μA	
T_{agc}	AGC Time Constant		33		μsec	$C_{agc} = 470\text{pF}$
V_{OFF}	Input Offset Voltage		1.9		V	$T_J = 25^\circ\text{C}$
$\frac{dV_{OFF}}{dTemp}$	Input Voltage Drift			-3	$\frac{\text{mV}}{^\circ\text{C}}$	$I_{IN} = 4\mu\text{A}$
V_{out}	Output Voltage		1.5		V	
R_{out}	Output Resistance	35	50	65	Ω	
I_{cc}	Supply Current		35	45	mA	

Note: All specifications guaranteed with $V_{DD} = +5.0\text{V} \pm 10\%$, $C_{IN} = 0.8\text{pf}$, $T_{JUNCTION} = -45^\circ\text{C}$ to 100°C unless otherwise noted.

Table 2: Absolute Maximum Rating

Symbol	Parameter	Maximum
V_{DD}	Power Supply	7 Volts
T_{STG}	Storage Temperature	-50°C to 125°C
I_{IN}	Input Current	10mA

Figure 1: VSC7902 Bonding Pad Diagram

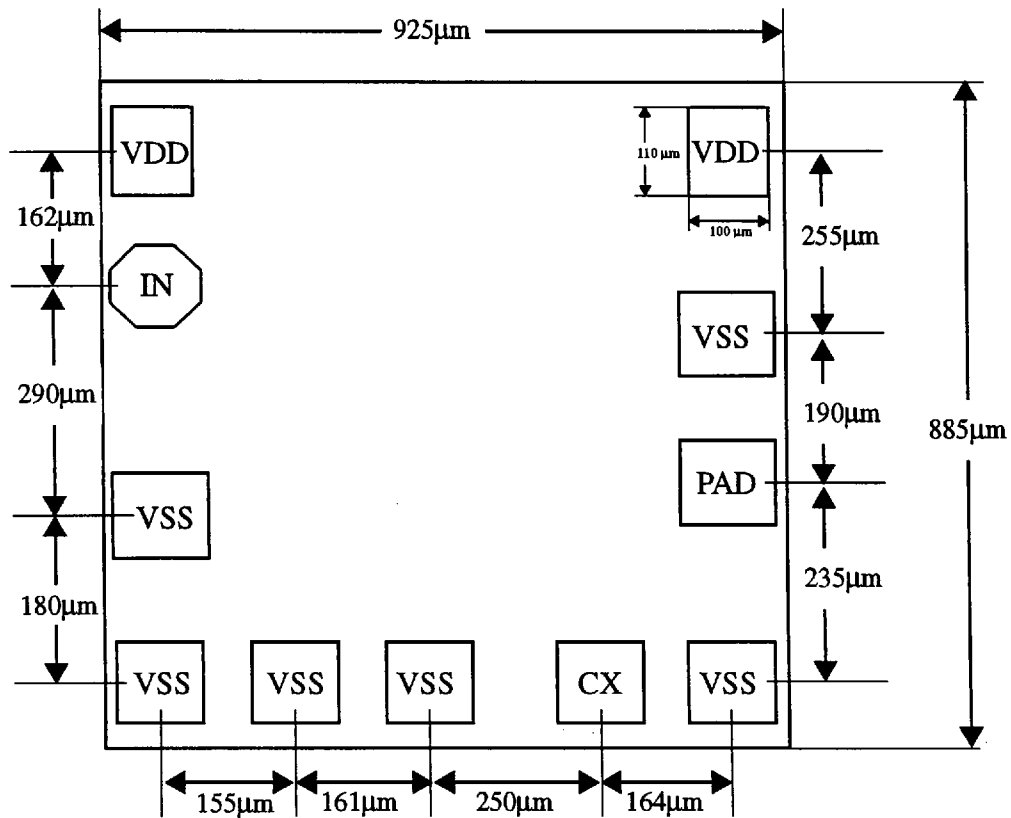

Part Numbering Scheme

VSC7902B

Package Style

X = Die Form

Notice

This document contains information on products that are in the preproduction phase of development. The information contained in this document is based on test results and initial product characterization. Characteristic data and other specifications are subject to change without notice. Therefore, the reader is cautioned to confirm that this datasheet is current prior to placing orders.

Warning

Vitesse Semiconductor Corporation's product are not intended for use in life support appliances, devices or systems. Use of a Vitesse product in such applications without the written consent is prohibited.