

## Features

- Extremely low gate charge
- 100% avalanche tested
- Super Junction Technology
- Pb-free lead plating; RoHS compliant; Halogen free

$V_{DS}$	700	V
$R_{DS(on),TYP@ V_{GS}=10V}$	350	m $\Omega$
$I_D$	11	A

### TO-220SF



Part ID	Package Type	Marking	Tube Information
VSF450N70HS3	TO-220SF	450N70H	50pcs/Tube

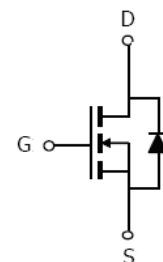

## Maximum ratings, at $T_A = 25^\circ\text{C}$ , unless otherwise specified

Symbol	Parameter	Rating	Unit
$V_{(BR)DSS}$	Drain-Source breakdown voltage	700	V
$V_{GS}$	Gate-Source voltage	$\pm 30$	V
$I_S$	Diode continuous forward current	$T_C = 25^\circ\text{C}$	11 A
$I_D$	Continuous drain current @ $V_{GS}=10V$	$T_C = 25^\circ\text{C}$	11 A
		$T_C = 100^\circ\text{C}$	7 A
$I_{DM}$	Pulse drain current tested ①	$T_C = 25^\circ\text{C}$	33 A
EAS	Avalanche energy, single pulsed ②	206	mJ
$P_D$	Maximum power dissipation	$T_C = 25^\circ\text{C}$	26 W
		$T_C = 100^\circ\text{C}$	10 W
$T_{STG}, T_J$	Storage and Junction Temperature Range	-55 to 150	$^\circ\text{C}$

## Thermal Characteristics

Symbol	Parameter	Typical	Unit
$R_{\theta JC}$	Thermal Resistance, Junction-to-Case	4.7	$^\circ\text{C/W}$
$R_{\theta JA}$	Thermal Resistance, Junction-to-Ambient	62.5	$^\circ\text{C/W}$

**Electrical Characteristics**

Symbol	Parameter	Condition	Min.	Typ.	Max.	Unit
<b>Static Electrical Characteristics @ T<sub>j</sub> = 25°C (unless otherwise stated)</b>						
V <sub>(BR)DSS</sub>	Drain-Source Breakdown Voltage	V <sub>GS</sub> =0V, I <sub>D</sub> =250μA	700	--	--	V
I <sub>DSS</sub>	Zero Gate Voltage Drain Current	V <sub>DS</sub> =700V, V <sub>GS</sub> =0V	--	--	1	μA
	Zero Gate Voltage Drain Current(T <sub>j</sub> =125°C)	V <sub>DS</sub> =560V, V <sub>GS</sub> =0V	--	--	50	μA
I <sub>GSS</sub>	Gate-Body Leakage Current	V <sub>GS</sub> =±30V, V <sub>DS</sub> =0V	--	--	±100	nA
V <sub>GS(TH)</sub>	Gate Threshold Voltage	V <sub>DS</sub> =V <sub>GS</sub> , I <sub>D</sub> =250μA	2.4	3	3.6	V
R <sub>DS(ON)</sub>	Drain-Source On-State Resistance ③	V <sub>GS</sub> =10V, I <sub>D</sub> =5.5A	--	350	420	mΩ
		T <sub>j</sub> =100°C	--	510	--	mΩ
<b>Dynamic Electrical Characteristics @ T<sub>j</sub>= 25°C (unless otherwise stated)</b>						
C <sub>iss</sub>	Input Capacitance	V <sub>DS</sub> =30V, V <sub>GS</sub> =0V, f=1MHz	655	770	885	pF
C <sub>oss</sub>	Output Capacitance		290	340	390	pF
C <sub>riss</sub>	Reverse Transfer Capacitance		15	20	25	pF
Q <sub>g</sub>	Total Gate Charge	V <sub>DS</sub> =350V, I <sub>D</sub> =11A, V <sub>GS</sub> =10V	--	18	--	nC
Q <sub>gs</sub>	Gate-Source Charge		--	4.2	--	nC
Q <sub>gd</sub>	Gate-Drain Charge		--	6.4	--	nC
<b>Switching Characteristics</b>						
t <sub>d(on)</sub>	Turn-on Delay Time	V <sub>DD</sub> =350V, I <sub>D</sub> =11A, R <sub>G</sub> =10Ω, V <sub>GS</sub> =10V	--	40	--	ns
t <sub>r</sub>	Turn-on Rise Time		--	36	--	ns
t <sub>d(off)</sub>	Turn-Off Delay Time		--	103	--	ns
t <sub>f</sub>	Turn-Off Fall Time		--	107	--	ns
<b>Source- Drain Diode Characteristics@ T<sub>j</sub>= 25°C (unless otherwise stated)</b>						
V <sub>SD</sub>	Forward on voltage	I <sub>SD</sub> =11A, V <sub>GS</sub> =0V	--	0.9	1.2	V
t <sub>rr</sub>	Reverse Recovery Time	T <sub>j</sub> =25°C, I <sub>sd</sub> =11A, V <sub>GS</sub> =0V	--	285	--	ns
Q <sub>rr</sub>	Reverse Recovery Charge	di/dt=100A/μs	--	2.9	--	μC

NOTE: ① Repetitive rating; pulse width limited by max junction temperature.

② Limited by T<sub>Jmax</sub>, starting T<sub>J</sub> = 25°C, L = 8mH, R<sub>G</sub> = 25Ω, I<sub>AS</sub> = 7A, V<sub>GS</sub> = 10V. Part not recommended for use above this value.

③ Pulse width ≤ 380μs; duty cycle ≤ 2%.

Typical Characteristics

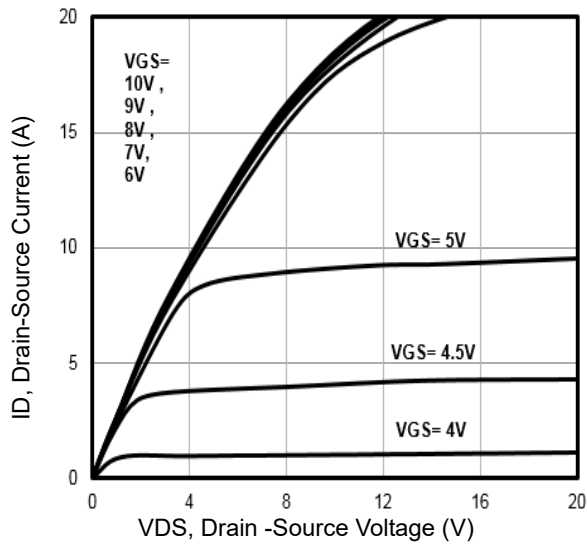

Fig1. Typical Output Characteristics

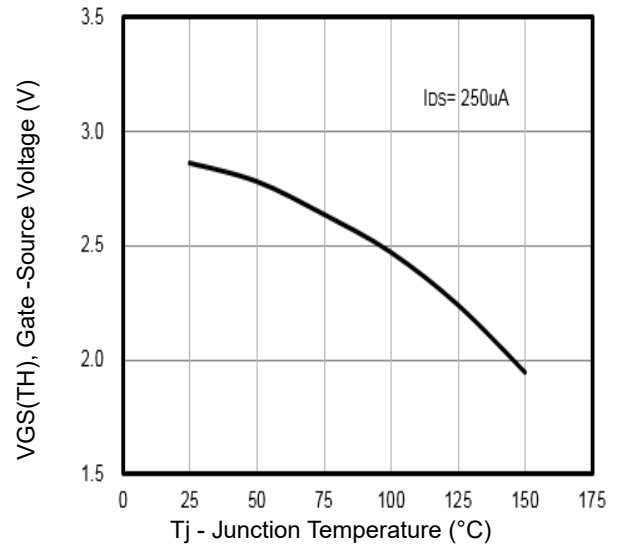

Fig2.  $V_{GS(TH)}$  Gate -Source Voltage Vs.  $T_j$

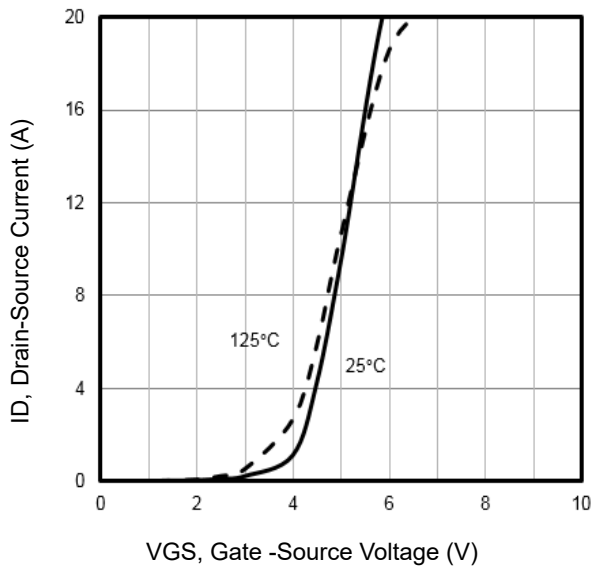

Fig3. Typical Transfer Characteristics

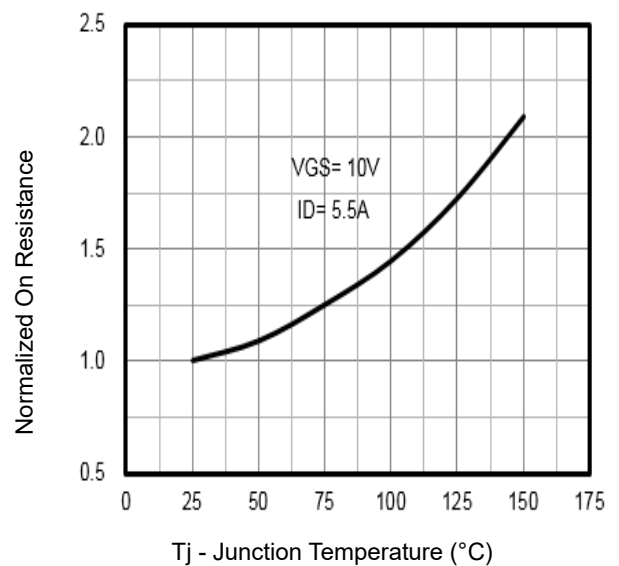

Fig4. Normalized On-Resistance Vs. Temperature

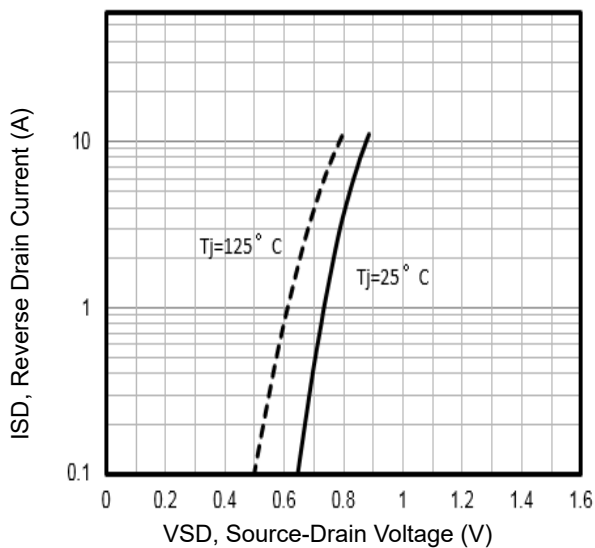

Fig5. Typical Source-Drain Diode Forward Voltage

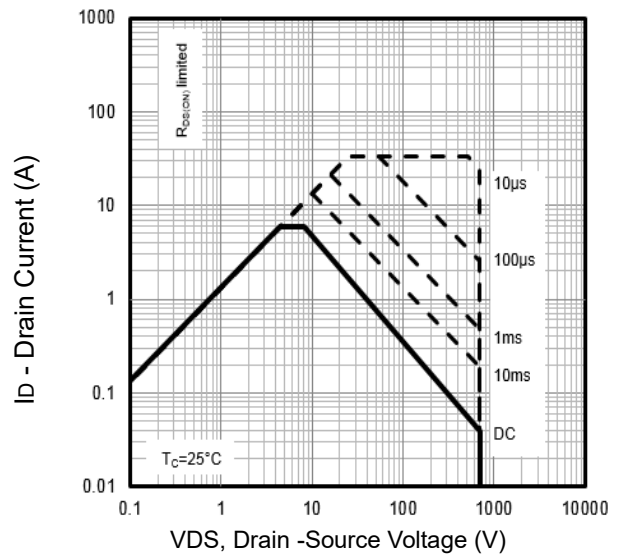

Fig6. Maximum Safe Operating Area

Typical Characteristics

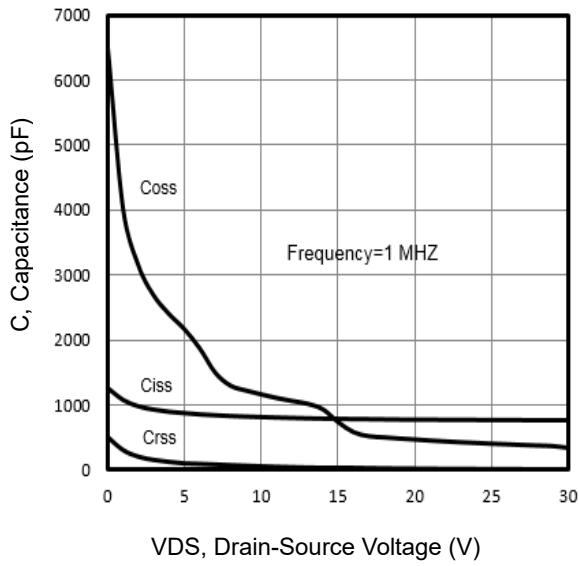

Fig7. Typical Capacitance Vs. Drain-Source Voltage

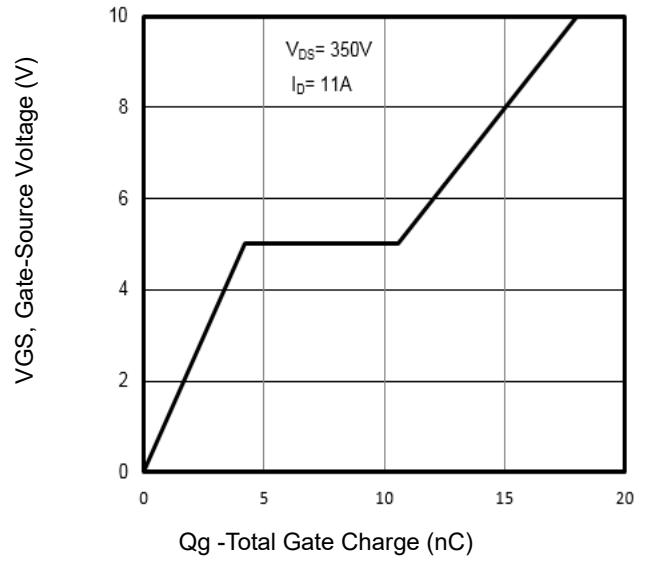

Fig8. Typical Gate Charge Vs. Gate-Source Voltage

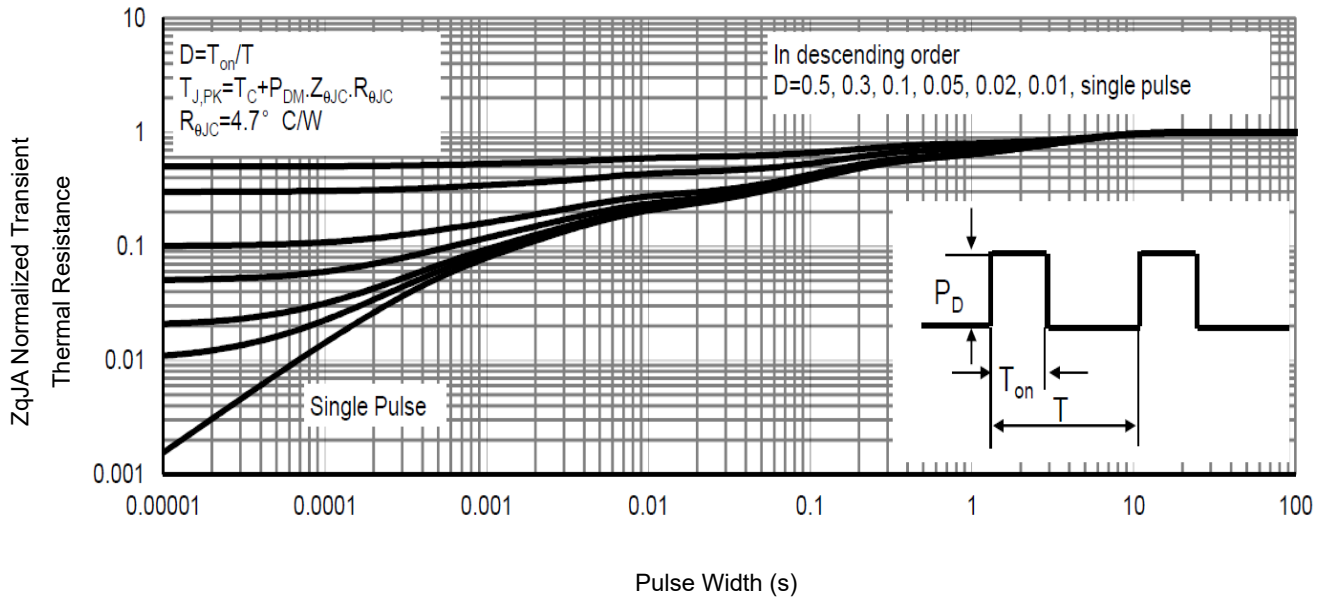

Fig9. Normalized Maximum Transient Thermal Impedance

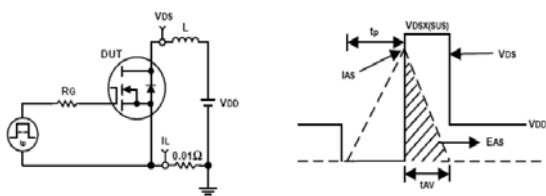

Fig10. Unclamped Inductive Test Circuit and waveforms

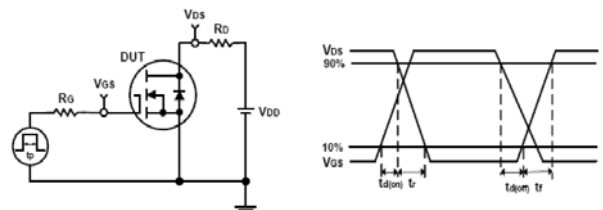
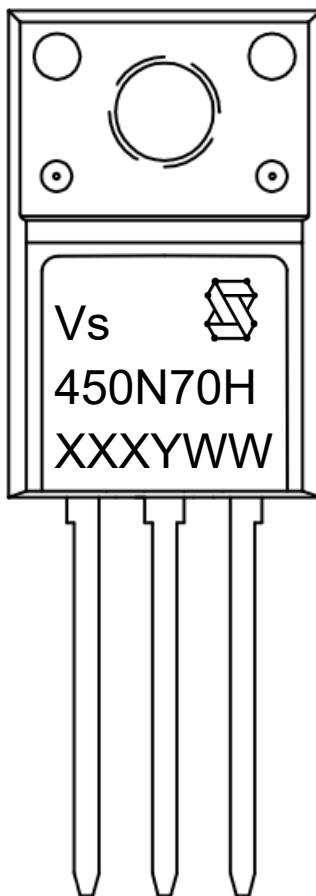

Fig11. Switching Time Test Circuit and waveforms

## Marking Information



1st line: Vanguard Code (Vs), Vanguard Logo

2nd line: Part Number (450N70H)

3rd line: Date code (XXXYWW)

XXX: Wafer Lot Number Code , code changed with Lot Number

Y: Year Code, (e.g. E=2017, F=2018, G=2019, H=2020, etc)

WW: Week Code (01 to 53)

## TO-220SF Package Outline Data

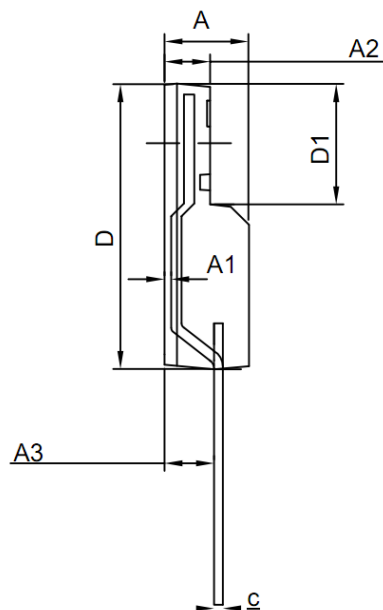
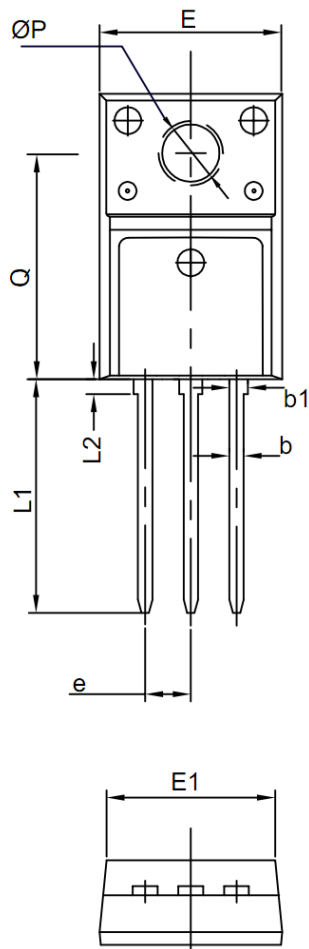

Symbol	Dimensions (unit: mm)		
	Min	Typ	Max
A	4.50	4.70	4.90
A1	--	0.43	--
A2	2.34	2.54	2.74
A3	2.66	2.76	2.86
b	0.59	0.69	0.79
b1	1.04	1.14	1.24
c	0.45	0.50	0.60
D	15.57	15.87	16.17
D1	6.50	6.70	6.90
e	2.44	2.54	2.64
E	9.96	10.16	10.36
E1	9.20	9.40	9.60
L1	12.70	13.00	13.30
L2	--	--	0.95
Q	12.27	12.57	12.87
$\varnothing P$	3.03	3.18	3.33

Note:

1. Dimensions do NOT include mold flash, protrusions or gate burrs.

## Customer Service

Sales and Service:

[sales@vgsemi.com](mailto:sales@vgsemi.com)

Vanguard Semiconductor CO., LTD

TEL: (86-755) -26902410

FAX: (86-755) -26907027

WEB: [www.vgsemi.com](http://www.vgsemi.com)