

1. SCOPE

The series SAW filter have broad line up products meeting all broadcast standard including NTSC, PAL and SECAM systems. These filters are composed of two interdigital transducers on a single-crystal, piezoelectrical chip. They are used in electronic equipments such as TV and so on.

2. Construction

2.1 Dimension and materials

Type: VSF45A1M

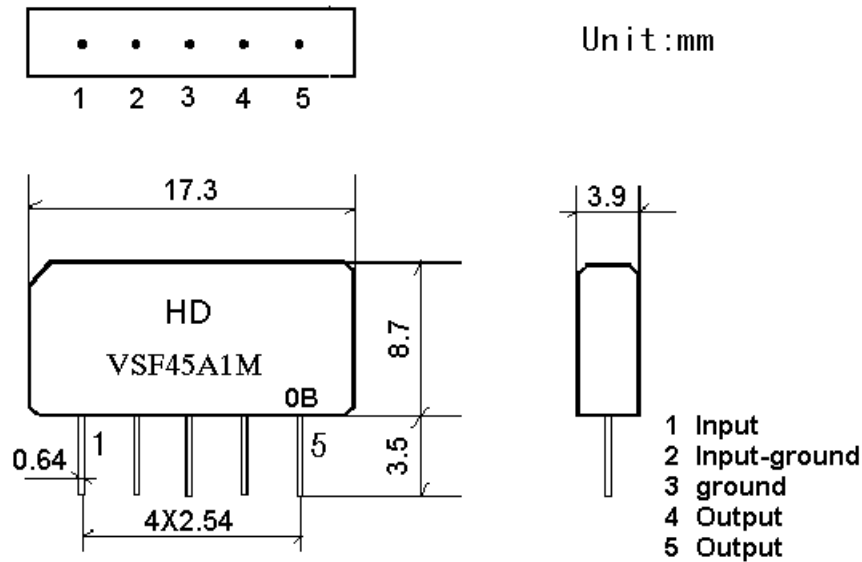

0: year (0,1,2,3,4,5,6,7,8,9)

B:product in this quarter(A:1~3,B:4~6,C:7~9,D:10~12)

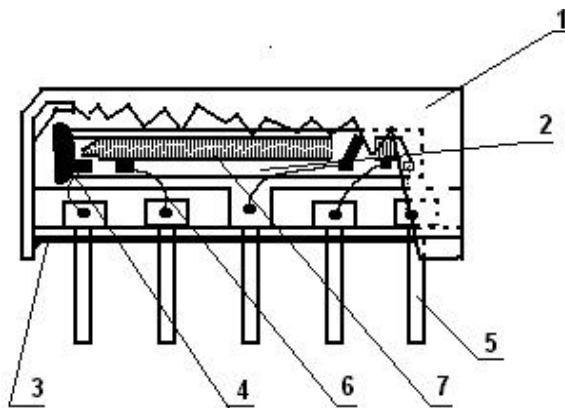

Components	Materials
1.Outer casing	PPS
2.Substrate	Lithium niobate
3.Base	Epoxy resin
4.Absorber	Epoxy resin
5.Lead	Cu alloy+Au plate
6.Bonding wire	AlSi alloy
7.Electrode	Al

2.2. Circuit construction, measurement circuit

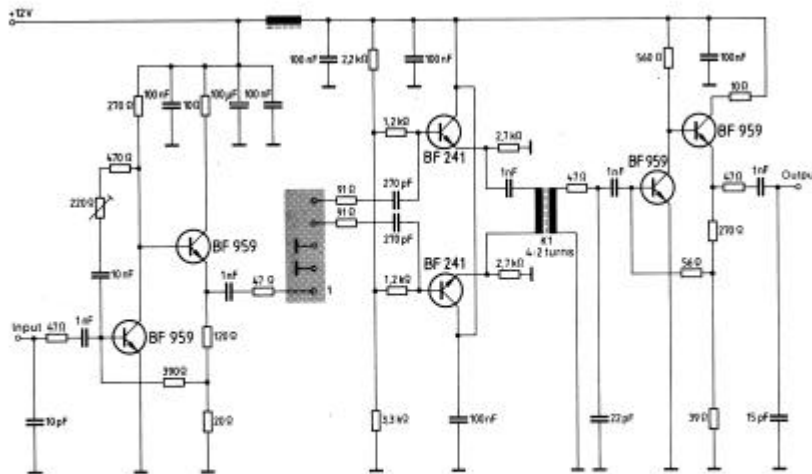

Test circuit for SIP-5 filter
Input impedance of the symmetrical post-amplifier: $2 \text{ k}\Omega$ in parallel with 3 pF

3. Characteristics

Standard atmospheric conditions

Unless otherwise specified, the standard range of atmospheric conditions for making measurements and tests is as follows;

- Ambient temperature : 15C to 35C
- Relative humidity : 25% to 85%
- Air pressure : 86kPa to 106kPa

Operating temperature rang

Operating temperature rang is the rang of ambient temperatures in which the filter can be operated continuously. $-10\text{C} \sim +60\text{C}$

Storage temperature rang

Storage temperature rang is the rang of ambient temperatures at which the filter can be stored without damage.

Conditions are as specified elsewhere in these specifications. $-40\text{C} \sim +70\text{C}$

Reference temperature +25C

3.1 Maximum Rating

DC voltage	VDC	12	V	Between any terminals
AC voltage	V _{pp}	10	V	Between any terminals

3.2 Electrical Characteristics

Source impedance $Z_s=50$
 Load impedance $Z_L=2k //3pF$ $T_A=25C$

Item	Freq	min	typ	max	
Center frequency (center between 3dB points)	Fo	-	43.56	-	MHz
Insertion attenuation Reference level	43.56MHz	13.4	15.4	17.4	dB
Relative attenuation	45.81MHz	-1.2	0.3	1.8	dB
	46.56MHz	2.9	4.4	5.9	dB
	42.23MHz	-1.7	-0.2	1.3	dB
	41.31MHz	-1.7	-0.2	1.3	dB
	39.81MHz	33.0	42.0		dB
	47.31MHz	32.0	42.0		dB
	51.31MHz	40.0	48.0		dB
Sidelobe	35.06~39.81MHz	31.0			dB
	47.81~55.06MHz	34.0			dB
Temperature coefficient		-72			ppm/k

3.3 Environmental Performance Characteristics

Item Test condition	Allowable change of absolute Level at center frequency(dB)
High temperature test 70C 1000H	< 1.0
Low temperature test -40C 1000H	< 1.0
Humidity test 40C 90-95% 1000H	< 1.0
Thermal shock -20C==25C==80C 20 cycle 30M 10M 30M	< 1.0
Solder temperature test Sold temp.260C for 10 sec.	< 1.0
Soldering Immerse the pins melt solder at 260C+5/-0C for 5 sec.	More then 95% of total area of the pins should be covered with solder

3.4 Mechanical Test

Item Test condition	Allowable change of absolute Level at center frequency(dB)
Vibration test 600-3300rpm amplitude 1.5mm 3 directions 2 H each	<1.0
Drop test On maple plate from 1 m high 3 times	<1.0
Lead pull test Pull with 1 kg force for 30 seconds	<1.0
Lead bend test 90° bending with 500g weigh 2 times	<1.0

3.5 Voltage Discharge Test

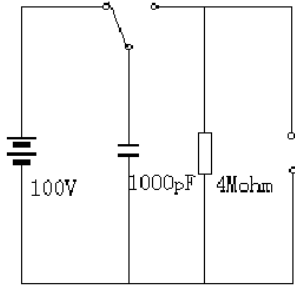
Item Test condition	Allowable change of absolute Level at center frequency(dB)
Surge test Between any two electrode 	<1.0

3.6 Frequency response

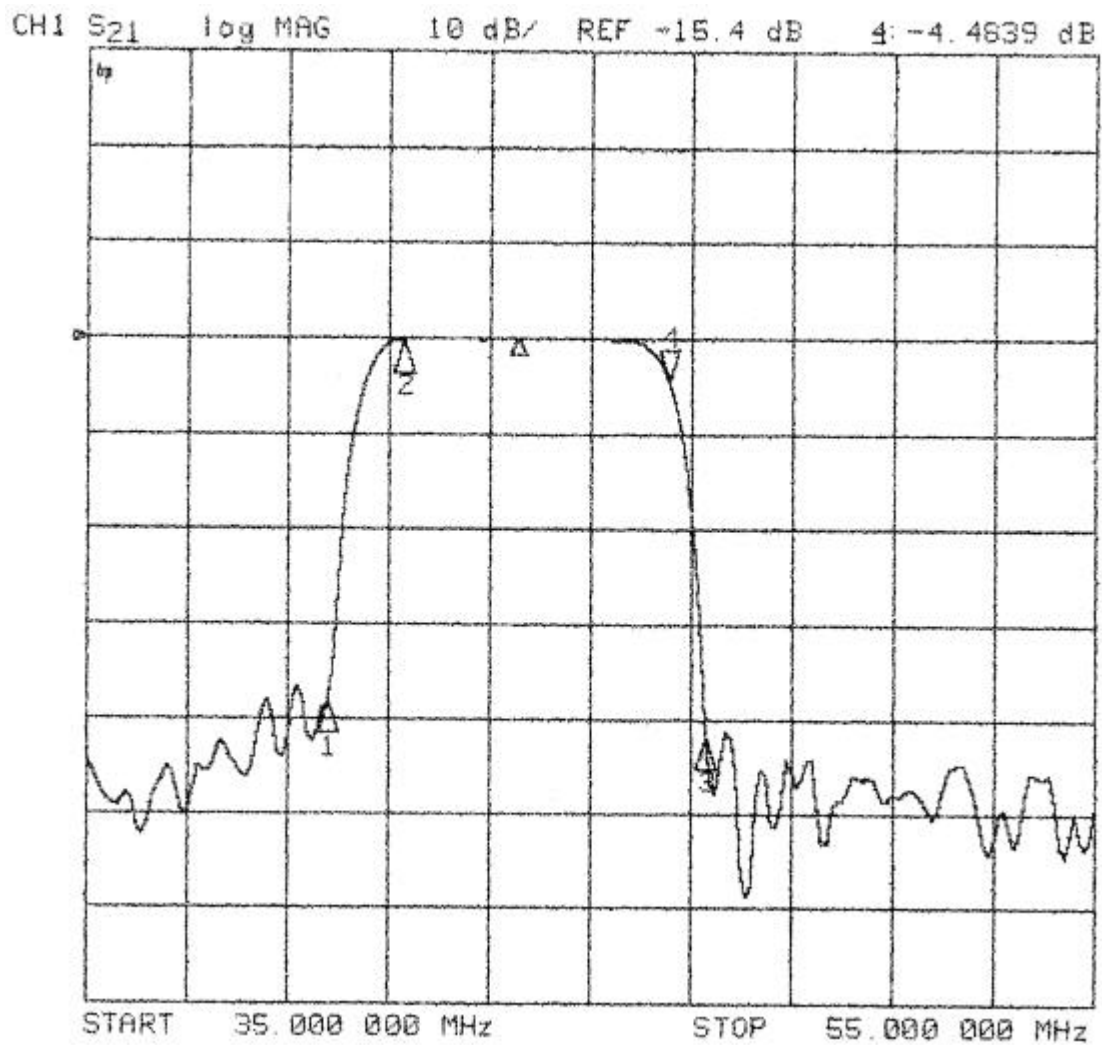

CH1 S21 delay 30 ns/ REF 1.291 μ s 4: -28.045 ns
CH2 S21 log MAG 1 dB/ REF -15.4 dB 4: -4.4383 dB

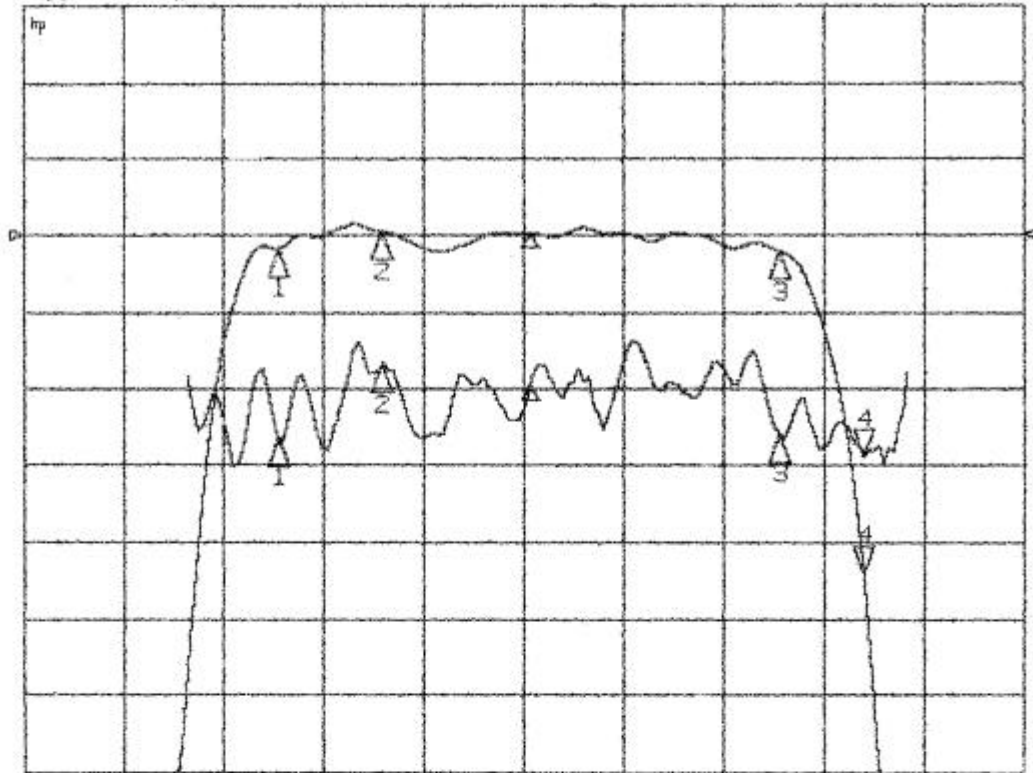

START 39.000 000 MHz

STOP 48.000 000 MHz

CH1 S21 log MAG 10 dB/ REF -15.84 dB

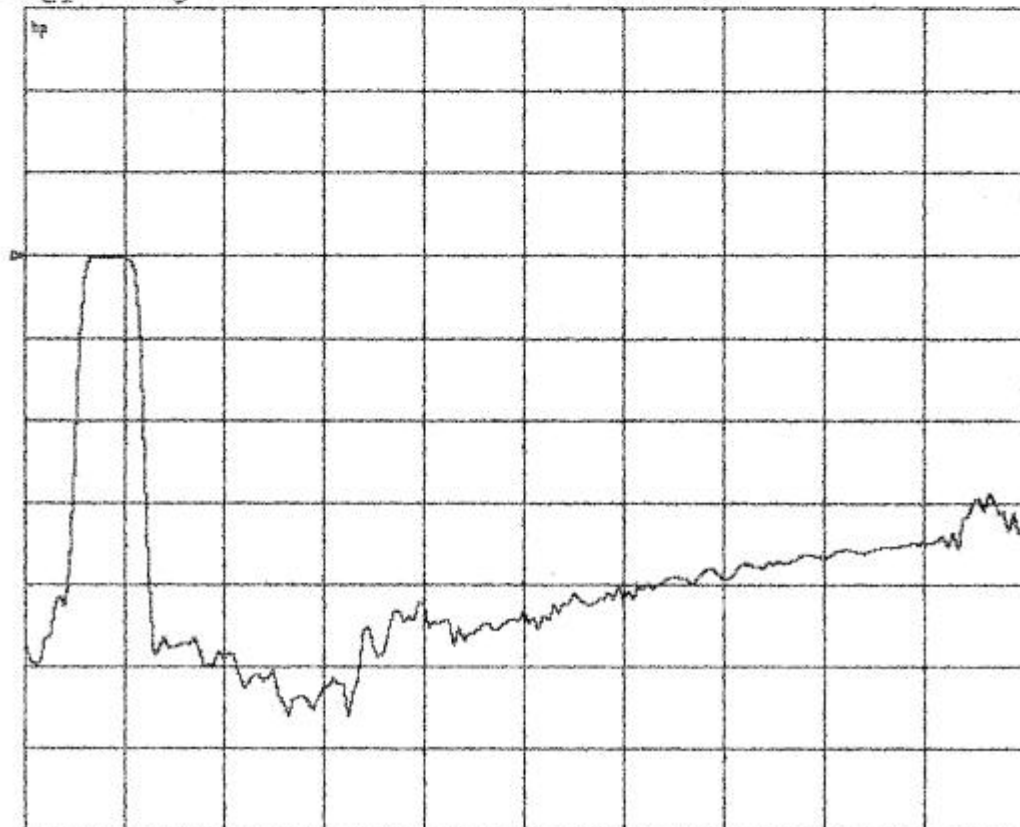

START 35.000 000 MHz

STOP 135.000 000 MHz

