

VSM0805

Vishay Foil Resistors



Bulk Metal[®] Foil Technology Discrete Surface Mount Chip Resistors

SURFACE MOUNT

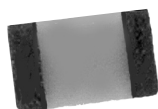
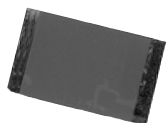
Product may not
be to scale

The VSM0805 represents the latest addition and smallest size to the Precision Bulk Metal[®] Foil (BMF) technology surface mount chip resistor series. The VSM0805 has a conventional full wrap around termination.

The BMF technology offers designers the lowest and most predictable absolute Temperature Coefficient Resistance available. The TCR is a process capability not a selection process and for the most part is independent of ohmic value and lot related variations.

The availability of tight absolute tolerance provides a good cost solution for the variability of other components when compiling the total error budget. BMF offers the best stability available; and is an order of magnitude better than thin film technology. The noise generated by the resistor is non measurable and its design and construction make it well suited for high frequency applications. The BMF is the ultimate resistor component for analog applications.

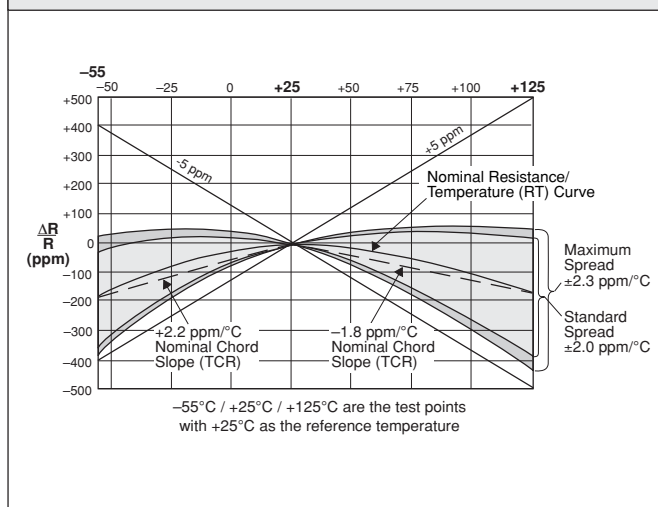
FIGURE 1 - NOMINAL TCR CURVE

The TCR for values < 100Ω are influenced by the termination composition and result in a deviation from this curve. Contact our application engineering department for detailed specification on low values

FEATURES

- Nominal TCR: + 0.6ppm/°C (0 to 25°C)
- 0.6ppm/°C (+ 25°C to + 60°C)
+ 2.2ppm/°C (- 55°C to + 25°C)
- 1.8ppm/°C (+ 25°C to + 125°C)
- Absolute Tolerance: to ± 0.01%
- Resistance Range: 5.5Ω to 12K
- Load Life Stability: ± 0.025% (2000 hours @ 70°C)
- Shelf Life Stability: 0.005% Maximum ΔR
- Voltage Coefficient: < 0.00001%/volt (< 0.1ppm/V)
- Current Noise: < - 40dB
- Non Inductive: < 0.08μH
- Terminal Finishes Available:
Lead (Pb)-free (Sn 99.3% Cu 0.7%)
Tin/Lead Alloy (Sn 62% Pb 36% Ag 2%)

TABLE 1 - TOLERANCE VERSUS RESISTANCE VALUE

VALUE (Ω)	TIGHTEST TOLERANCE (%)*
250Ω to 12K	± 0.01
100Ω to < 250	± 0.02
50Ω to < 100	± 0.05
25Ω to < 50	± 0.1
10Ω to < 25	± 0.25
5.5Ω to <10	± 0.5

*Tighter tolerances are available. Please contact Application Engineering. Soldering temperatures used during installation may cause resistance to shift up to 0.05%.

TABLE 2 - TYPICAL PERFORMANCE SPECIFICATIONS

TEST	MIL-PRF-55342G CHARACTERISTIC. E ΔR LIMITS	VSM MAXIMUM ΔR LIMITS*
Thermal Shock	± 0.10%	± 0.02%
Low Temperature Operation	± 0.10%	± 0.02%
Short Time Overload	± 0.10%	± 0.02%
High Temperature Exposure	± 0.10%	± 0.05%
Resistance to Bonding	± 0.20%	± 0.05%
Moisture Resistance	± 0.20%	± 0.10%
Life 2000 hours @ + 70°C	± 0.50%	± 0.025%

*As shown + 0.01 Ohms to allow for measurement errors at low values.

SALES

• ISRAEL: foilsales.israel@vishay.com • FRANCE/SWITZERLAND/SOUTHERN EUROPE: foilsales.eusouth@vishay.com • AMERICAS: foilsales.usa@vishay.com
• ASIA/JAPAN: foilsales.asia@vishay.com • UK/HOLLAND/SCANDANAVIA: foilsales.eunorth@vishay.com • GERMANY/CZECH REPUBLIC/AUSTRIA: foilsales.eucentral@vishay.com

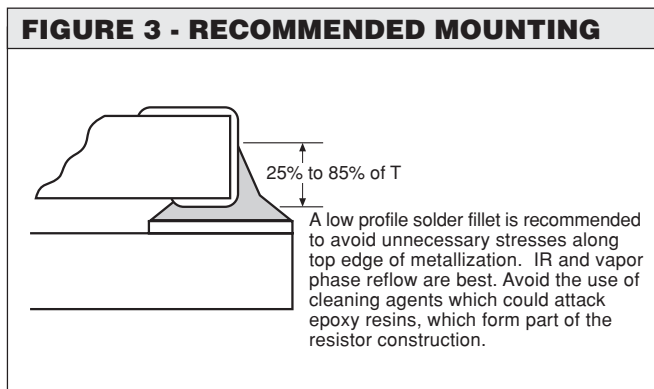
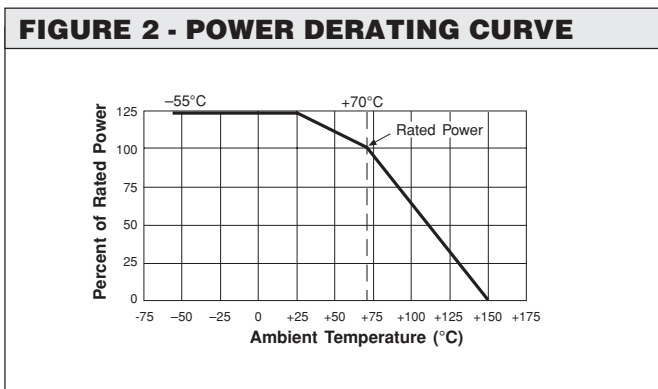
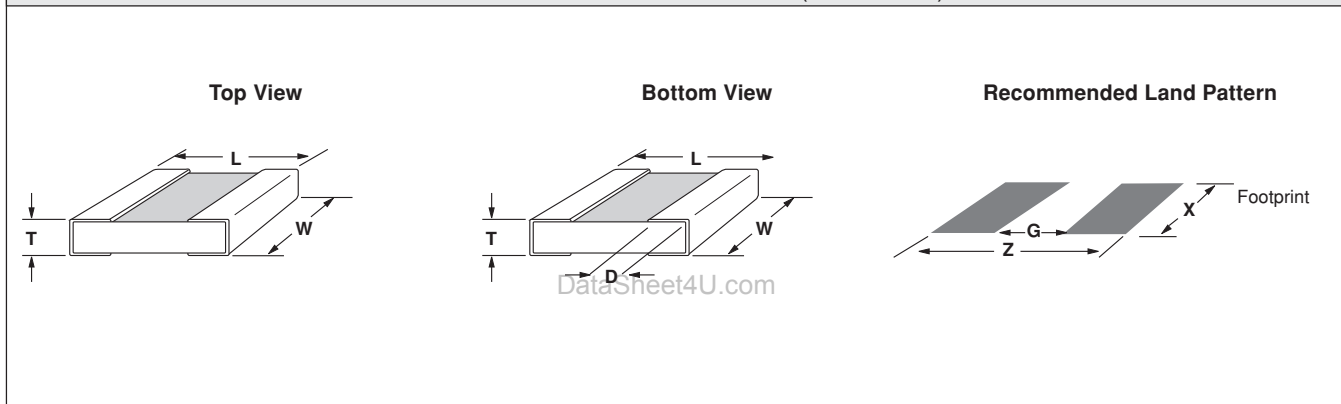

TABLE 3 - CHIP SIZES AND SPECIFICATIONS in inches (millimeters)



CHIP SIZE	L ± 0.005 (0.13)	W ± 0.005 (0.13)	T MAXIMUM	D ± 0.005 (0.13)	POWER + 70°C (mW)	MAXIMUM VOLTAGE (V)	RESISTANCE RANGE (Ω)	MAXIMUM WEIGHT (mG)	Z* ± 0.004 (0.10)	G* ± 0.004 (0.10)	X* ± 0.004 (0.10)
0805	0.080 (2.03)	0.050 (1.27)	0.025 (0.64)	0.015 (0.38)	50	22	5.5 - 12K	6	0.122 (3.10)	0.028 (0.70)	0.050 (1.27)

*Land Pattern Dimensions (Z, G, X) are per IPC-782A

TABLE 4 - ORDERING INFORMATION - VSM STYLE CHIP RESISTORS

MODEL	CHIP SIZE	RESISTANCE VALUE			TOLERANCE	TERMINATION	PACKAGING
VSM	0805	RESISTANCE RANGE	LETTER DESIGNATOR	MULTIPLIER FACTOR	T ± 0.01% Q ± 0.02% A ± 0.05% B ± 0.1% C ± 0.25% D ± 0.5% F ± 1.0%	S - Lead (Pb)-free B - Tin/Lead	T = Tape and Reel W = Waffle Pack
		5Ω to <1KΩ	R	x 1.0			
		1K to 12KΩ	K	x 10 ³			
				Example: 10K000 = 10.0KΩ			

SALES
 • ISRAEL: foilsales.israel@vishay.com • FRANCE/SWITZERLAND/SOUTHERN EUROPE: foilsales.eusouth@vishay.com • AMERICAS: foilsales.usa@vishay.com
 • ASIA/JAPAN: foilsales.asia@vishay.com • UK/HOLLAND/SCANDANAVIA: foilsales.eunorth@vishay.com • GERMANY/CZECH REPUBLIC/AUSTRIA: foilsales.eucentral@vishay.com