

Features

- N-Channel, 10V Logic Level Control
- Enhancement mode
- Very low on-resistance
- Fast Switching
- 100% Avalanche Tested
- Pb-free lead plating; RoHS compliant

Halogen-Free

Part ID	Package Type	Marking	Tape and reel information
VSP003N06HS	PDFN5x6	003N06H	3000pcs/Reel

V_{DS}	60	V
$R_{DS(on),TYP}@ V_{GS}=10V$	4.4	m Ω
I_D	120	A

PDFN5x6

Drain Pin5-8



Source Pin 1-3

Maximum ratings, at $T_j=25^\circ\text{C}$, unless otherwise specified

Symbol	Parameter	Rating	Unit
$V_{(BR)DSS}$	Drain-Source breakdown voltage	60	V
I_S	Diode continuous forward current	$T_C=25^\circ\text{C}$ 120	A
I_D	Continuous drain current@ $V_{GS}=10V$	$T_C=25^\circ\text{C}$ 120	A
		$T_C=100^\circ\text{C}$ 76	A
I_{DM}	Pulse drain current tested ①	$T_C=25^\circ\text{C}$ 480	A
IAS	Avalanche current max	$L=0.5\text{mH}$ 48	A
EAS	Avalanche energy, single pulsed ②	100	mJ
P_D	Maximum power dissipation	$T_C=25^\circ\text{C}$ 125	W
V_{GS}	Gate-Source voltage	± 20	V
$T_{STG} T_J$	Storage and operating temperature range	-55 to 150	$^\circ\text{C}$

Thermal Characteristics

Symbol	Parameter	Typical	Unit
$R_{\theta JC}$	Thermal Resistance-Junction to Case	1.0	$^\circ\text{C/W}$
$R_{\theta JA}$	Thermal Resistance Junction-Ambient	48	$^\circ\text{C/W}$

Symbol	Parameter	Condition	Min.	Typ.	Max.	Unit
Static Electrical Characteristics @ T_c = 25°C (unless otherwise stated)						
V _{(BR)DSS}	Drain-Source Breakdown Voltage	V _{GS} =0V I _D =250μA	60	--	--	V
I _{DSS}	Zero Gate Voltage Drain Current(T _c =25°C)	V _{DS} =60V,V _{GS} =0V	--	--	1	μA
	Zero Gate Voltage Drain Current(T _c =125°C)	V _{DS} =60V,V _{GS} =0V	--	--	100	μA
I _{GSS}	Gate-Body Leakage Current	V _{GS} =±20V,V _{DS} =0V	--	--	±100	nA
V _{GS(TH)}	Gate Threshold Voltage	V _{DS} =V _{GS} ,I _D =250μA	2.0	3.0	4.0	V
R _{DS(ON)}	Drain-Source On-State Resistance ^③	V _{GS} =10V, I _D =25A	--	4.4	4.8	mΩ
Dynamic Electrical Characteristics @ T_c = 25°C (unless otherwise stated)						
C _{iss}	Input Capacitance	V _{DS} =25V,V _{GS} =0V, f=1MHz	--	5220	--	pF
C _{oss}	Output Capacitance		--	570	--	pF
C _{rss}	Reverse Transfer Capacitance		--	380	--	pF
R _g	Gate Resistance	f=1MHz	--	1.8	--	Ω
Q _g	Total Gate Charge	V _{DS} =30V,I _D =20A, V _{GS} =10V	--	124	--	nC
Q _{gs}	Gate-Source Charge		--	11	--	nC
Q _{gd}	Gate-Drain Charge		--	14	--	nC
Switching Characteristics						
t _{d(on)}	Turn-on Delay Time	V _{DD} =30V, I _D =10A, R _G =3.5Ω, V _{GS} =10V	--	26	--	nS
t _r	Turn-on Rise Time		--	23	--	nS
t _{d(off)}	Turn-Off Delay Time		--	45	--	nS
t _f	Turn-Off Fall Time		--	12	--	nS
Source- Drain Diode Characteristics @ T_c = 25°C (unless otherwise stated)						
V _{SD}	Forward on voltage	I _{SD} =30A,V _{GS} =0V	--	0.83	1.2	V
t _{rr}	Reverse Recovery Time	T _j =25°C,I _{sd} =20A, di/dt=500A/μs	--	32	--	nS
Q _{rr}	Reverse Recovery Charge		--	141	--	nC

NOTE:

- ① Repetitive rating; pulse width limited by max. junction temperature.
- ② Limited by T_{Jmax}, starting T_J = 25°C, L = 0.5mH,R_G = 25Ω, I_{AS} = 20A, V_{GS} =10V. Part not recommended for use above this value
- ③ Pulse width ≤ 300μs; duty cycle≤ 2%.

Typical Characteristics

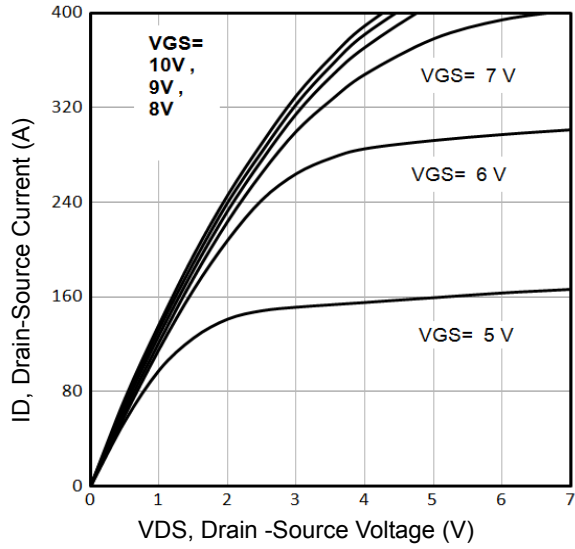

Fig1. Typical Output Characteristics

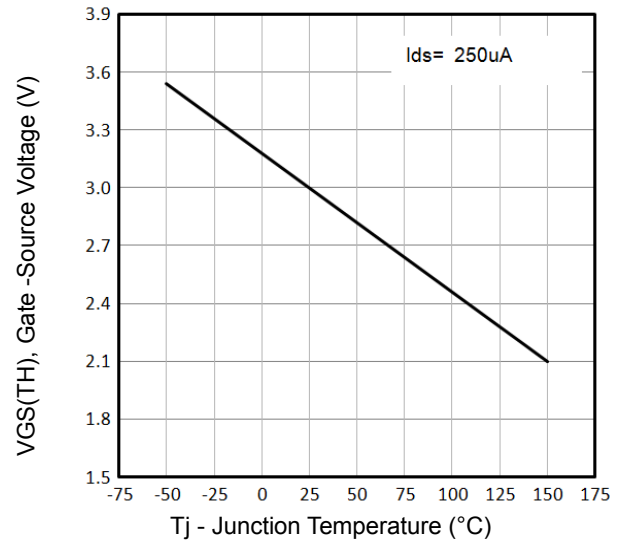

Fig2. $V_{GS(TH)}$ Gate -Source Voltage Vs. T_j

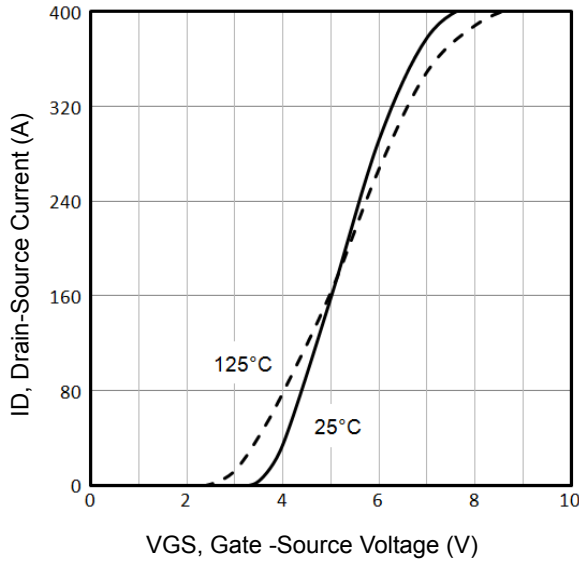

Fig3. Typical Transfer Characteristics

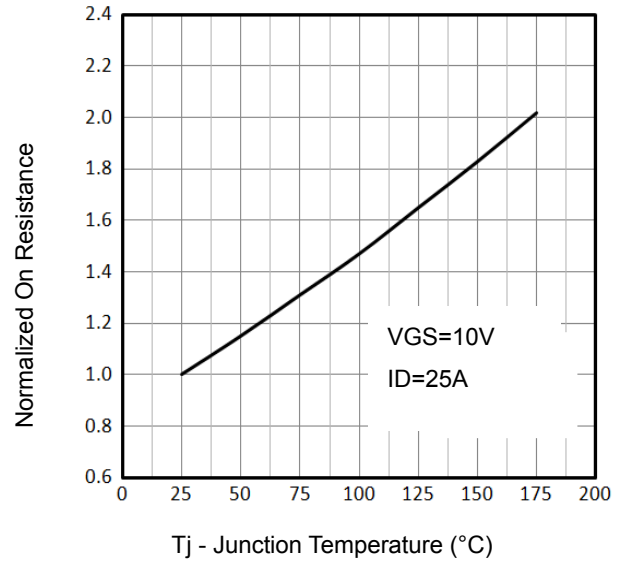

Fig4. Normalized On-Resistance Vs. T_j

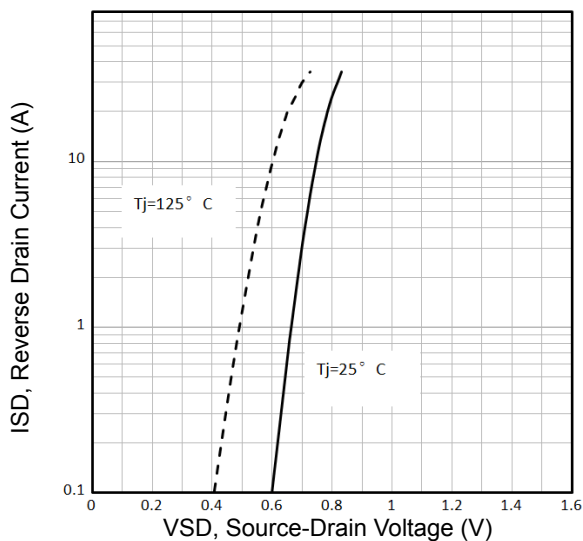

Fig5. Typical Source-Drain Diode Forward Voltage

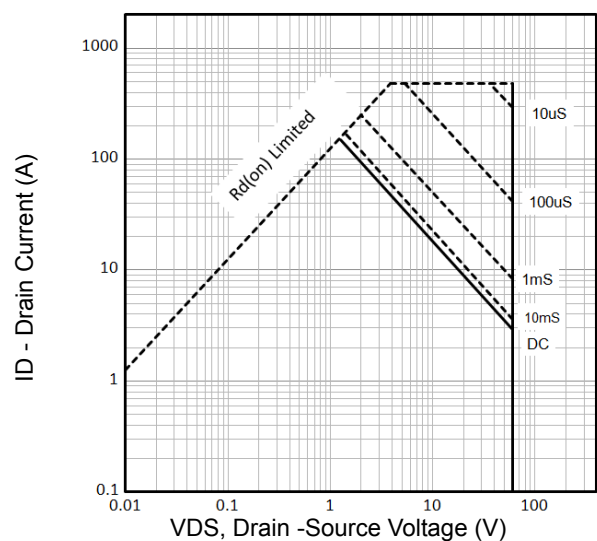

Fig6. Maximum Safe Operating Area

Typical Characteristics

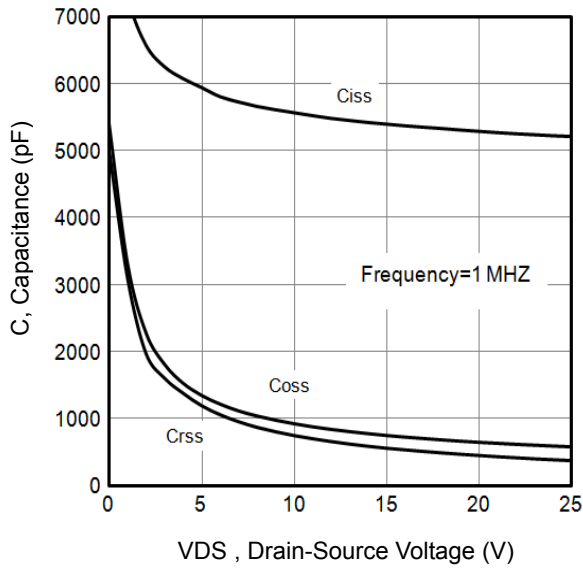

Fig7. Typical Capacitance Vs.Drain-Source Voltage

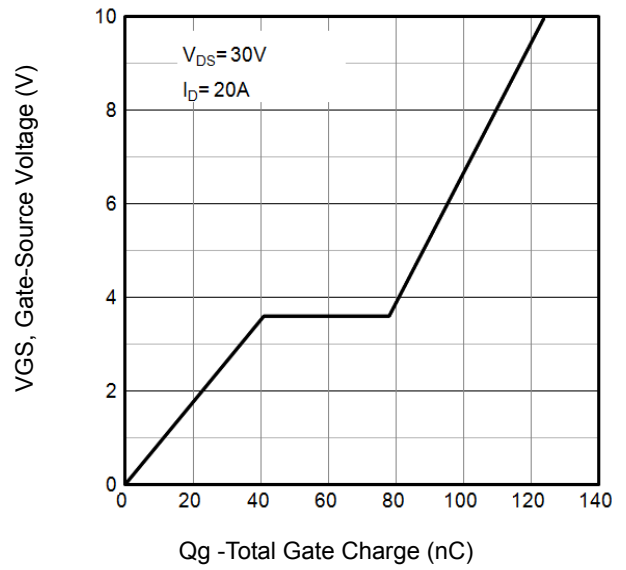

Fig8. Typical Gate Charge Vs.Gate-Source Voltage

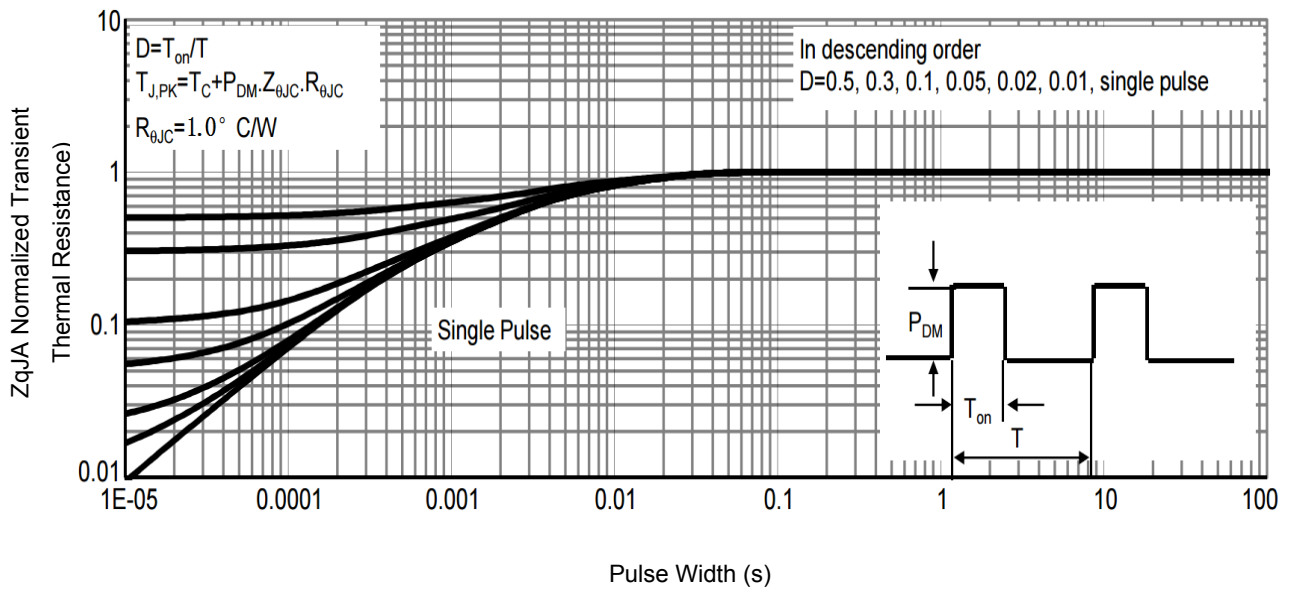

Fig9 . Normalized Maximum Transient Thermal Impedance

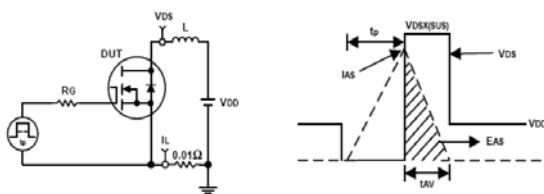

Fig10. Unclamped Inductive Test Circuit and waveforms

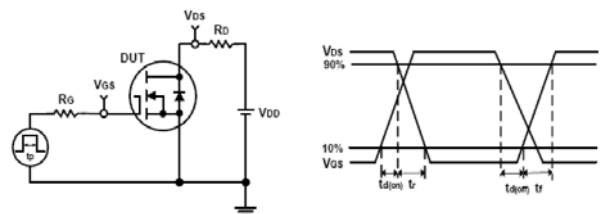
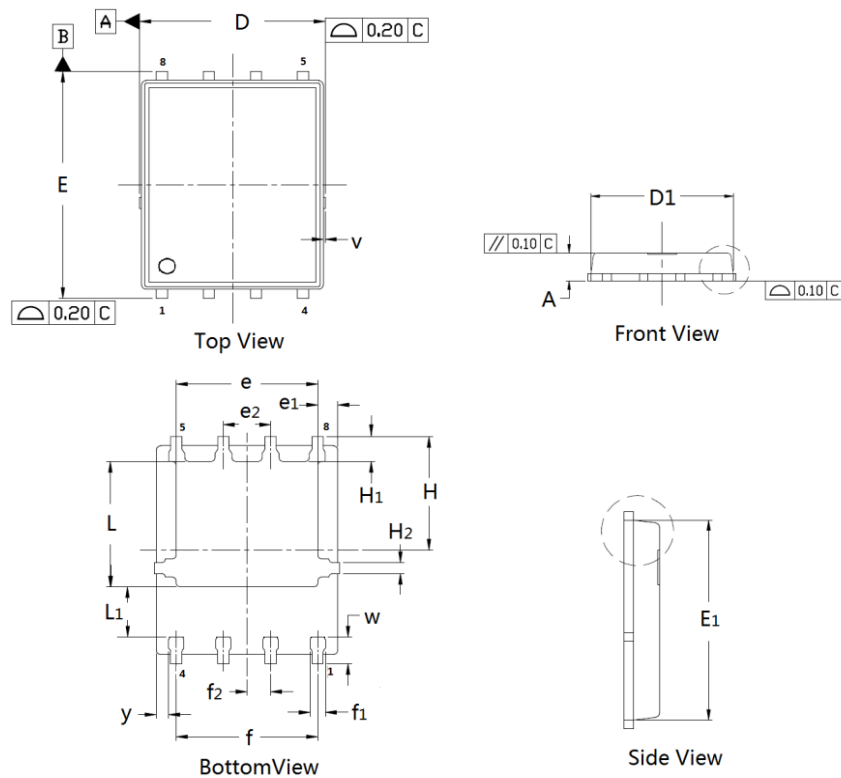

Fig11. Switching Time Test Circuit and waveforms

PDFN5×6 Package Outline Data

DIMENSIONS (unit : mm)

Symbol	Min	Typ	Max	Symbol	Min	Typ	Max
A	0.90	1.02	1.10	D	4.90	4.98	5.10
D ₁	4.80	4.89	5.00	E	6.00	6.11	6.20
E ₁	5.65	5.74	5.85	e	3.72	3.80	3.92
e ₁	--	0.54	--	e ₂	--	1.27	--
f	--	3.82	--	f ₁	0.31	0.37	0.51
f ₂	--	0.64	--	H	--	3.15	--
H ₁	0.59	0.63	0.79	H ₂	0.26	0.28	0.32
L	3.38	3.45	3.58	L ₁	--	1.39	--
v	--	0.13	--	w	0.64	0.68	0.84
y	--	0.34	--		--		--

Customer Service
Sales and Service:
sales@vgsemi.com
Vanguard Semiconductor CO., LTD
TEL: (86-755) -26902410

FAX: (86-755) -26907027

WEB: www.vgsemi.com