

## Features

- Enhancement mode
- Low on-resistance  $R_{DS(on)}$  @  $V_{GS}=4.5\text{ V}$
- VitoMOS<sup>®</sup> II Technology
- 100% Avalanche test
- Pb-free lead plating; RoHS compliant



Part ID	Package Type	Marking	Tape and reel information
VSP003N06MS-G	PDFN5x6	003N06M	3000PCS/Reel

$V_{DS}$	60	V
$R_{DS(on),TYP} @ V_{GS}=10\text{ V}$	2.5	m $\Omega$
$R_{DS(on),TYP} @ V_{GS}=4.5\text{ V}$	4.3	m $\Omega$
$I_D$	125	A

### PDFN5x6

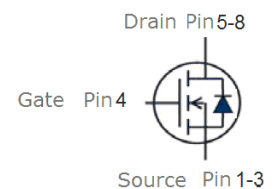
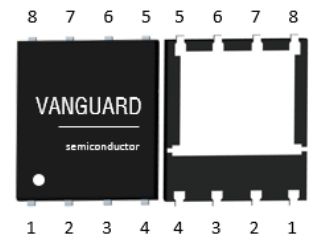

## Maximum ratings, at $T_A = 25^\circ\text{C}$ , unless otherwise specified

Symbol	Parameter	Rating	Unit
$V_{(BR)DSS}$	Drain-Source breakdown voltage	60	V
$V_{GS}$	Gate-Source voltage	$\pm 20$	V
$I_S$	Diode continuous forward current	$T_C = 25^\circ\text{C}$	125 A
$I_D$	Continuous drain current @ $V_{GS}=10\text{V}$	$T_C = 25^\circ\text{C}$	125 A
		$T_C = 100^\circ\text{C}$	79 A
$I_{DM}$	Pulse drain current tested ①	$T_C = 25^\circ\text{C}$	500 A
$I_{DSM}$	Continuous drain current @ $V_{GS}=10\text{V}$	$T_A = 25^\circ\text{C}$	31 A
		$T_A = 70^\circ\text{C}$	24 A
EAS	Avalanche energy, single pulsed ②	100	mJ
$P_D$	Maximum power dissipation	$T_C = 25^\circ\text{C}$	69 W
$P_{DSM}$	Maximum power dissipation ③	$T_A = 25^\circ\text{C}$	4.2 W
$T_{STG}, T_J$	Storage and Junction Temperature Range	-55 to 150	$^\circ\text{C}$

## Thermal Characteristics

Symbol	Parameter	Typical	Unit
$R_{\theta JC}$	Thermal Resistance, Junction-to-Case	1.8	$^\circ\text{C/W}$
$R_{\theta JA}$	Thermal Resistance, Junction-to-Ambient	30	$^\circ\text{C/W}$

**Electrical Characteristics**

Symbol	Parameter	Condition	Min.	Typ.	Max.	Unit
<b>Static Electrical Characteristics @ T<sub>j</sub>=25°C (unless otherwise stated)</b>						
V <sub>(BR)DSS</sub>	Drain-Source Breakdown Voltage	V <sub>GS</sub> =0V, I <sub>D</sub> =250μA	60	--	--	V
I <sub>DSS</sub>	Zero Gate Voltage Drain Current	V <sub>DS</sub> =60V, V <sub>GS</sub> =0V	--	--	1	μA
	Zero Gate Voltage Drain Current(T <sub>j</sub> =125°C)	V <sub>DS</sub> =60V, V <sub>GS</sub> =0V	--	--	100	μA
I <sub>GSS</sub>	Gate-Body Leakage Current	V <sub>GS</sub> =±20V, V <sub>DS</sub> =0V	--	--	±100	nA
V <sub>GS(TH)</sub>	Gate Threshold Voltage	V <sub>DS</sub> =V <sub>GS</sub> , I <sub>D</sub> =250μA	1.3	1.9	2.5	V
R <sub>DS(ON)</sub>	Drain-Source On-State Resistance④	V <sub>GS</sub> =10V, I <sub>D</sub> =30A	--	2.5	3.5	mΩ
		T <sub>j</sub> =100°C	--	3.2	--	mΩ
R <sub>DS(ON)</sub>	Drain-Source On-State Resistance④	V <sub>GS</sub> =4.5V, I <sub>D</sub> =20A	--	4.3	6	mΩ
<b>Dynamic Electrical Characteristics @ T<sub>j</sub> = 25°C (unless otherwise stated)</b>						
C <sub>iss</sub>	Input Capacitance	V <sub>DS</sub> =30V, V <sub>GS</sub> =0V, f=1MHz	3020	3550	4080	pF
C <sub>oss</sub>	Output Capacitance		1355	1595	1835	pF
C <sub>riss</sub>	Reverse Transfer Capacitance		25	35	45	pF
R <sub>g</sub>	Gate Resistance	f=1MHz	--	0.8	--	Ω
Q <sub>g</sub> (10V)	Total Gate Charge	V <sub>DS</sub> =30V, I <sub>D</sub> =30A, V <sub>GS</sub> =10V	--	48	--	nC
Q <sub>g</sub> (4.5V)	Total Gate Charge		--	22	--	nC
Q <sub>gs</sub>	Gate-Source Charge		--	11	--	nC
Q <sub>gd</sub>	Gate-Drain Charge		--	5.2	--	nC
<b>Switching Characteristics</b>						
t <sub>d(on)</sub>	Turn-on Delay Time	V <sub>DD</sub> =30V, I <sub>D</sub> =30A, R <sub>G</sub> =3Ω, V <sub>GS</sub> =10V	--	11	--	ns
t <sub>r</sub>	Turn-on Rise Time		--	45	--	ns
t <sub>d(off)</sub>	Turn-Off Delay Time		--	34	--	ns
t <sub>f</sub>	Turn-Off Fall Time		--	32	--	ns
<b>Source- Drain Diode Characteristics @ T<sub>j</sub> = 25°C (unless otherwise stated)</b>						
V <sub>SD</sub>	Forward on voltage	I <sub>SD</sub> =30A, V <sub>GS</sub> =0V	--	0.8	1.2	V
t <sub>rr</sub>	Reverse Recovery Time	T <sub>j</sub> =25°C, I <sub>sd</sub> =30A, V <sub>GS</sub> =0V	--	53	--	ns
Q <sub>rr</sub>	Reverse Recovery Charge	di/dt=100A/μs	--	51	--	nC

NOTE: ① Repetitive rating; pulse width limited by max junction temperature.

② Limited by T<sub>Jmax</sub>, starting T<sub>J</sub> = 25°C, L = 0.5mH, R<sub>G</sub> = 25Ω, I<sub>AS</sub> = 20A, V<sub>GS</sub> = 10V. Part not recommended for use above this value

③ The power dissipation P<sub>DSM</sub> is based on R<sub>θJA</sub> and the maximum allowed junction temperature of 150°C.

④ Pulse width ≤ 380μs; duty cycles ≤ 2%.

Typical Characteristics

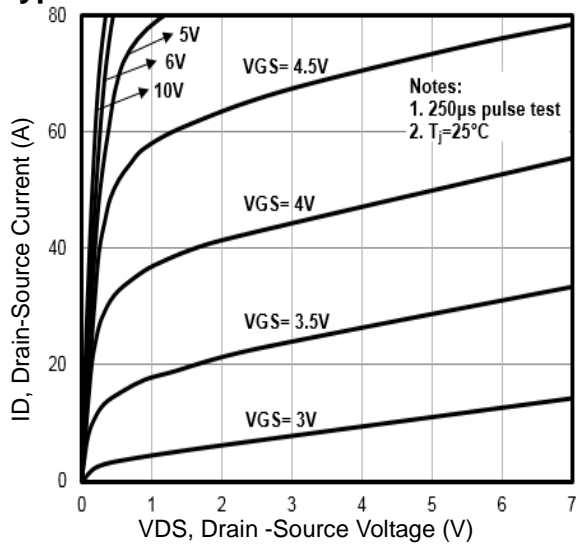

Fig1. Typical Output Characteristics

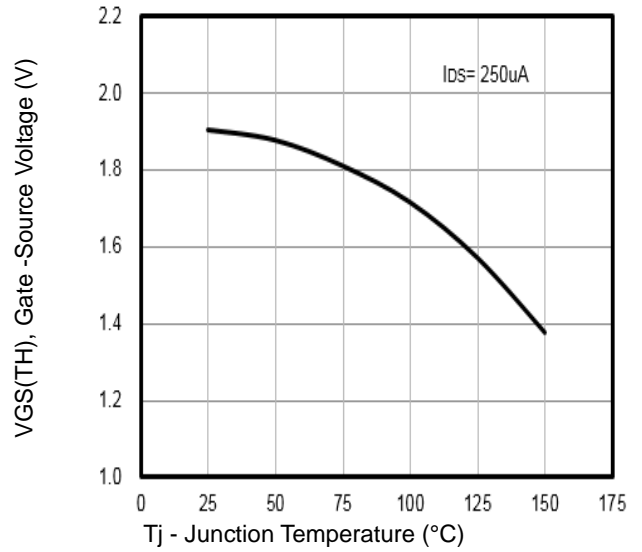

Fig2.  $V_{GS(TH)}$  Gate -Source Voltage Vs.  $T_j$

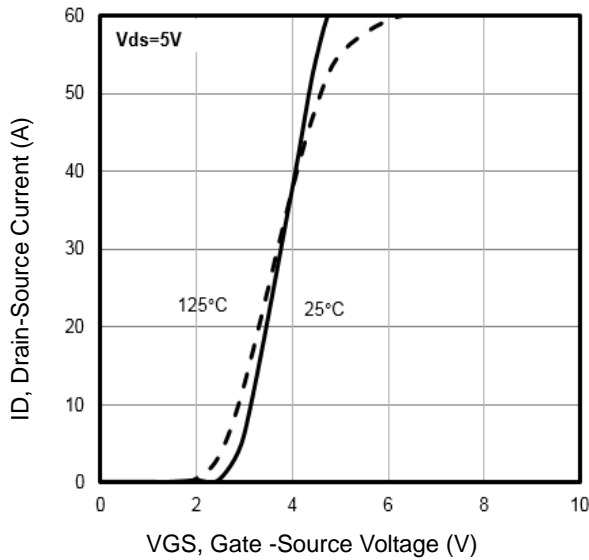

Fig3. Typical Transfer Characteristics

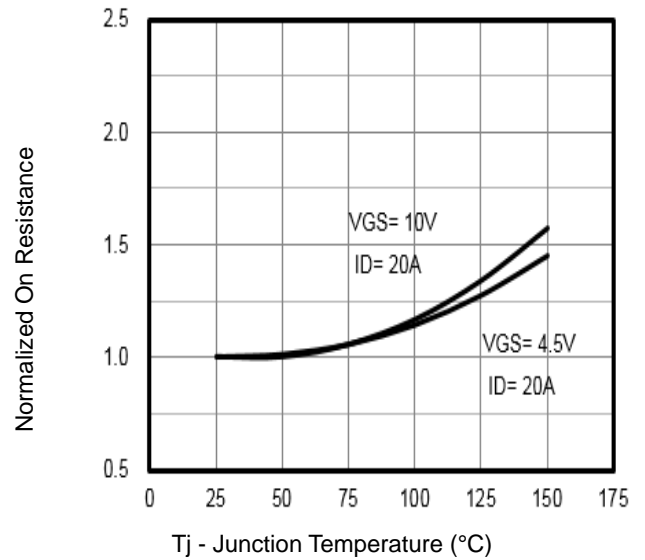

Fig4. Normalized On-Resistance Vs.  $T_j$

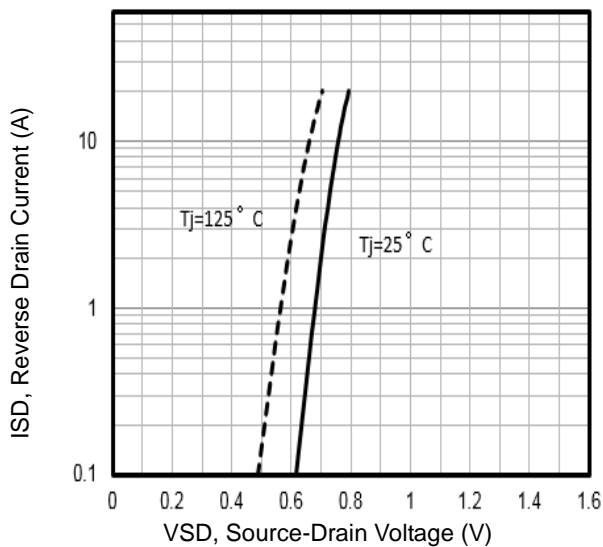

Fig5. Typical Source-Drain Diode Forward Voltage

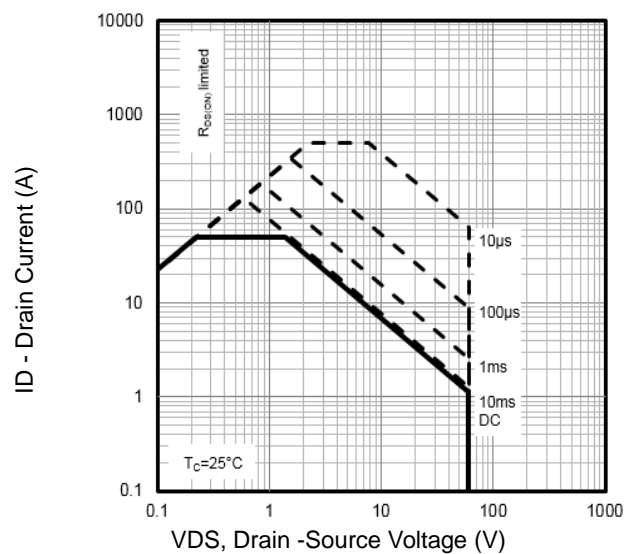

Fig6. Maximum Safe Operating Area

Typical Characteristics

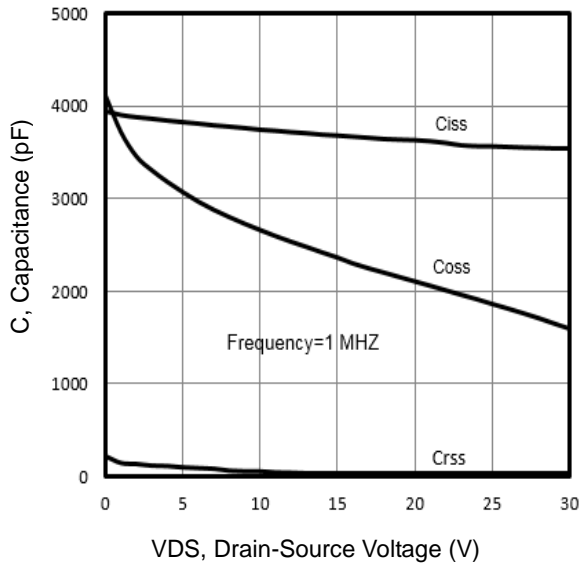

Fig7. Typical Capacitance Vs. Drain-Source Voltage

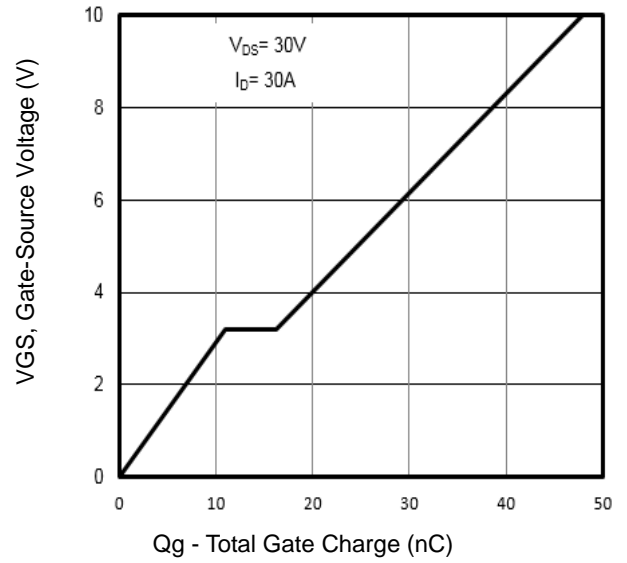

Fig8. Typical Gate Charge Vs. Gate-Source Voltage

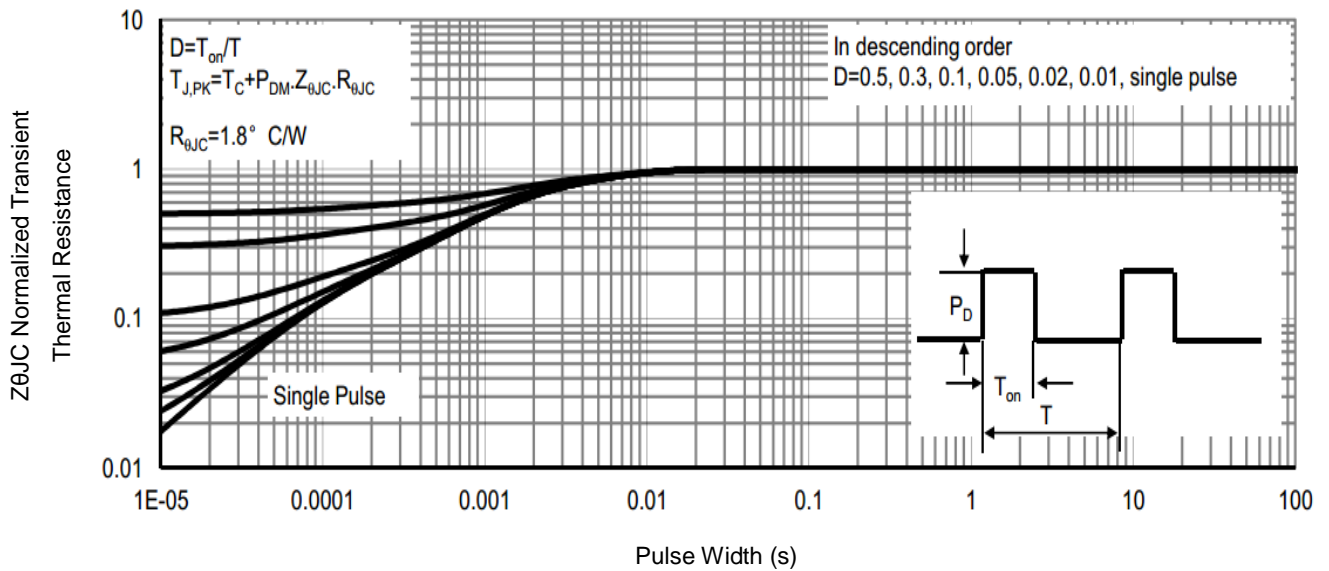

Fig9. Normalized Maximum Transient Thermal Impedance

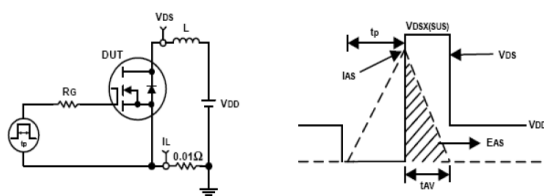

Fig10. Unclamped Inductive Test Circuit and waveforms

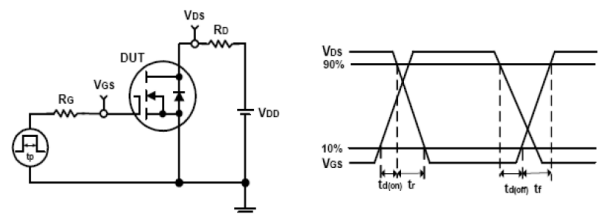
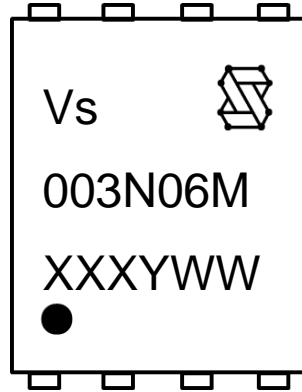

Fig11. Switching Time Test Circuit and waveforms

**Marking Information**



1st line: Vanguard Code (Vs), Vanguard Logo

2nd line: Part Number (003N06M)

3rd line: Date code (XXXYWW)

XXX: Wafer Lot Number Code , code changed with Lot Number

Y: Year Code, (e.g. E=2017, F=2018, G=2019, H=2020, etc)

WW: Week Code (01 to 53)

**PDFN5x6 Package Outline Data**

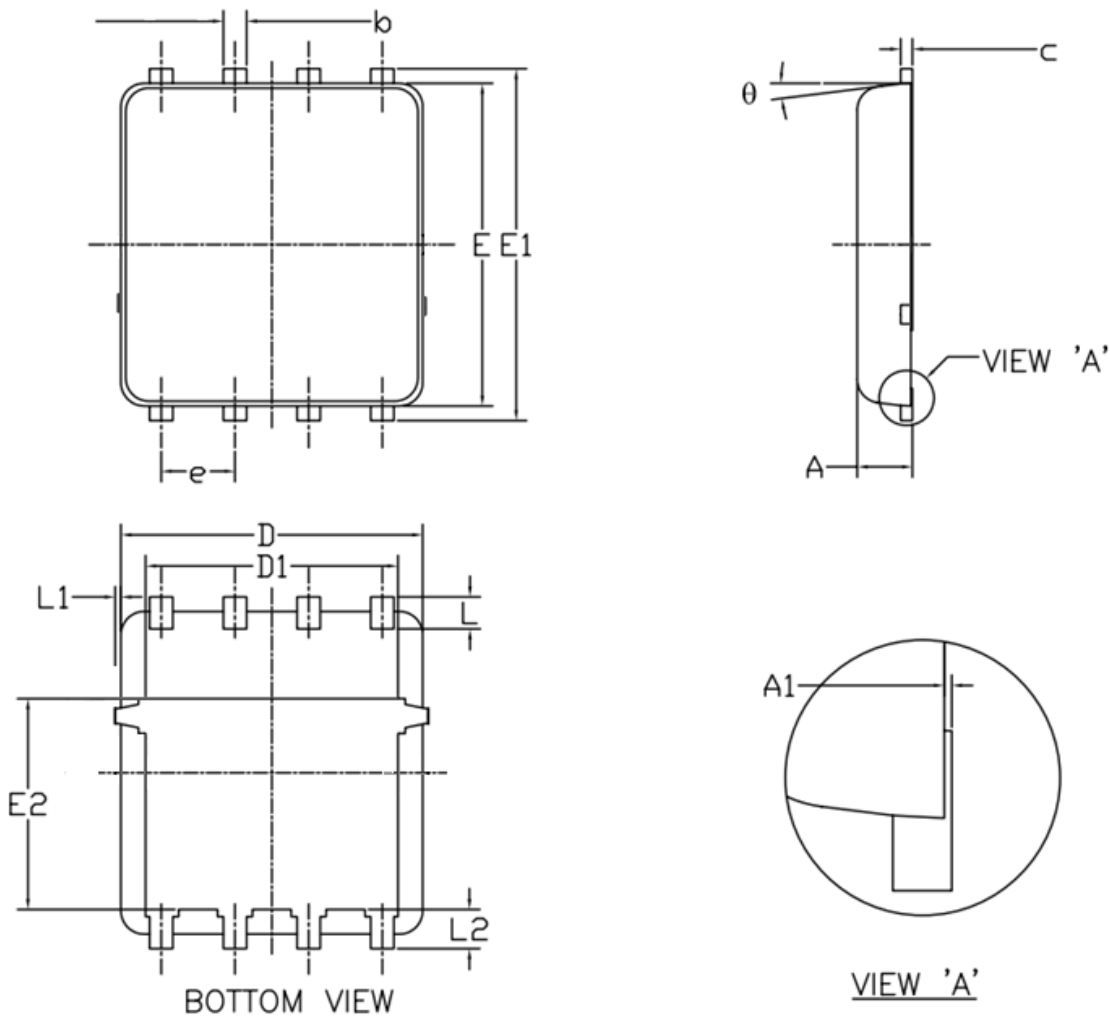

Symbol	DIMENSIONS ( unit : mm )		
	Min	Typ	Max
<b>A</b>	0.90	1.00	1.20
<b>A1</b>	0.00	--	0.05
<b>b</b>	0.30	0.40	0.51
<b>c</b>	0.20	0.25	0.33
<b>D</b>	4.80	4.90	5.40
<b>D1</b>	3.61	4.00	4.25
<b>E</b>	5.65	5.80	6.06
<b>E1</b>	5.90	6.10	6.35
<b>E2</b>	3.38	3.58	3.92
<b>e</b>	1.27 BSC		
<b>L</b>	0.51	0.61	0.71
<b>L1</b>	--	--	0.15
<b>L2</b>	0.41	0.51	0.61
<b>θ</b>	0°	--	12°

Notes:

1. Refer to JEDEC MO-240 variation AA.
2. Dimensions "D" and "E" do NOT include mold flash protrusions or gate burrs.
3. Dimensions "D" and "E" include interterminal flash or protrusion. Interterminal flash or protrusion shall not exceed 0.25mm per side.

**Customer Service**

**Sales and Service:**

[sales@vgsemi.com](mailto:sales@vgsemi.com)

**Vanguard Semiconductor CO., LTD**

**TEL:** (86-755) -26902410

**FAX:** (86-755) -26907027

**WEB:** [www.vgsemi.com](http://www.vgsemi.com)