

Features

- P-Channel, -5V Logic Level Control
- Enhancement mode
- Very low on-resistance $R_{DS(on)}$ @ $V_{GS}=-4.5\text{ V}$
- Fast Switching
- 100% Avalanche Tested
- Pb-free lead plating; RoHS compliant; Hg-Free

V_{DS}	-100	V
$R_{DS(on),TYP}$ @ $V_{GS}=-10\text{ V}$	36	m Ω
$R_{DS(on),TYP}$ @ $V_{GS}=-4.5\text{ V}$	38	m Ω
I_D	-30	A



Part ID	Package Type	Marking	Tape and reel information
VSP040P10MS	PDFN5x6	040P10M	3000pcs/reel

PDFN5x6

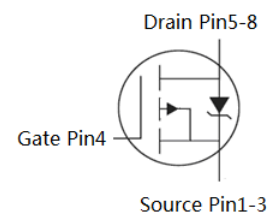

Absolute Maximum Ratings

Symbol	Parameter	Rating	Unit
Common Ratings (T_c=25°C Unless Otherwise Noted)			
V_{GS}	Gate-Source Voltage	±20	V
$V_{(BR)DSS}$	Drain-Source Breakdown Voltage	-100	V
T_{STG} T_J	Storage and operating temperature range①	-55 to 150	°C
I_S	Diode Continuous Forward Current	$T_C=25^\circ\text{C}$ -30	A
Mounted on Large Heat Sink			
I_{DM}	Pulse Drain Current Tested ①	$T_C=25^\circ\text{C}$ -120	A
I_D	Continuous Drain current@ $V_{GS}=10\text{V}$	$T_C=25^\circ\text{C}$ -30	A
P_D	Maximum Power Dissipation	$T_C=25^\circ\text{C}$ 73	W
$R_{\theta JC}$	Thermal Resistance-Junction to Case	1.7	°C/W
$R_{\theta JA}$	Thermal Resistance Junction-Ambient($t_s<10\text{s}$)	50	°C/W
Drain-Source Avalanche Ratings			
EAS	Avalanche Energy, Single Pulsed ②	306	mJ

Symbol	Parameter	Condition	Min.	Typ.	Max.	Unit
Static Electrical Characteristics @ T_J = 25°C (unless otherwise stated)						
V _{(BR)DSS}	Drain-Source Breakdown Voltage	V _{GS} =0V I _D =-250μA	-100	--	--	V
I _{DSS}	Zero Gate Voltage Drain Current(Tc=25°C)	V _{DS} =-100V,V _{GS} =0V	--	--	-1	μA
	Zero Gate Voltage Drain Current(Tc=125°C)	V _{DS} =-100V,V _{GS} =0V	--	--	-10	μA
I _{GSS}	Gate-Body Leakage Current	V _{GS} =±20V,V _{DS} =0V	--	--	±100	nA
V _{GS(TH)}	Gate Threshold Voltage	V _{DS} =V _{GS} ,I _D =-250μA	-1.0	-2.0	-3.0	V
R _{DS(ON)}	Drain-Source On-State Resistance ^③	V _{GS} =-10V, I _D =-30A	--	36	45	mΩ
R _{DS(ON)}	Drain-Source On-State Resistance ^③	V _{GS} =-4.5V, I _D =-15A	--	38	50	mΩ
Dynamic Electrical Characteristics @ T_J = 25°C (unless otherwise stated)						
C _{iss}	Input Capacitance	V _{DS} =-30V,V _{GS} =0V, f=1MHz	--	6590	--	pF
C _{oss}	Output Capacitance		--	225	--	pF
C _{rss}	Reverse Transfer Capacitance		--	175	--	pF
Q _g	Total Gate Charge	V _{DS} =-50V,I _D =-10A, V _{GS} =-10V	--	69	--	nC
Q _{gs}	Gate-Source Charge		--	14	--	nC
Q _{gd}	Gate-Drain Charge		--	19	--	nC
Switching Characteristics						
t _{d(on)}	Turn-on Delay Time	V _{DD} =-50V, I _D =-1A, R _G =6.8Ω, V _{GS} =-10V	--	22	--	nS
t _r	Turn-on Rise Time		--	26	--	nS
t _{d(off)}	Turn-Off Delay Time		--	74	--	nS
t _f	Turn-Off Fall Time		--	66	--	nS
Source- Drain Diode Characteristics @ T_J = 25°C (unless otherwise stated)						
I _{SD}	Source-drain current(Body Diode)	T _c =25°C	--	--	-30	A
V _{SD}	Forward on voltage	I _{SD} =-30A,V _{GS} =0V	--	0.90	-1.3	V
t _{rr}	Reverse Recovery Time	T _J =25°C,I _{sd} =-10A, V _{GS} =0V	--	52	--	nS
Q _{rr}	Reverse Recovery Charge	di/dt=-500A/μs		128		nC

NOTE:

- ① Repetitive rating; pulse width limited by max. junction temperature.
- ② Limited by T_{Jmax}, starting T_J = 25°C, L = 0.5mH,R_G = 25Ω, I_{AS} = -35A, V_{GS} = -10V. Part not recommended for use above this value
- ③ Pulse width ≤ 300μs; duty cycle ≤ 2%.

Typical Characteristics

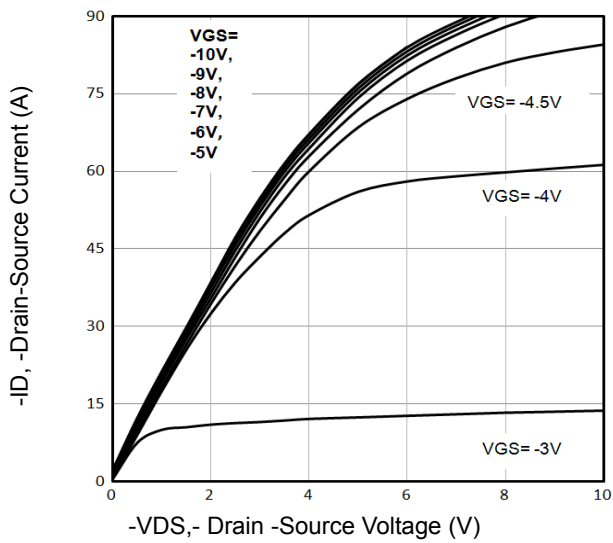

Fig1. Typical Output Characteristics

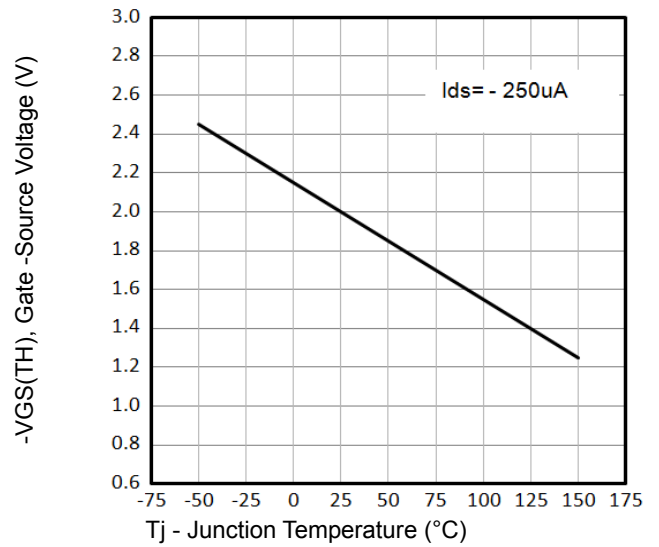

Fig2. $-V_{GS(TH)}$ Gate -Source Voltage Vs. T_j

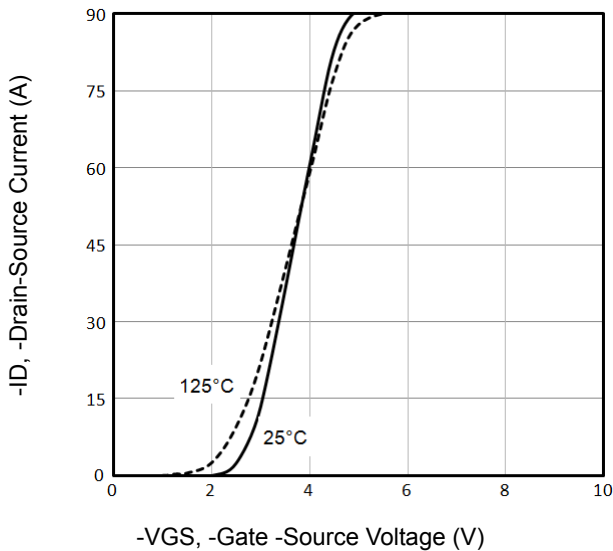

Fig3. Typical Transfer Characteristics

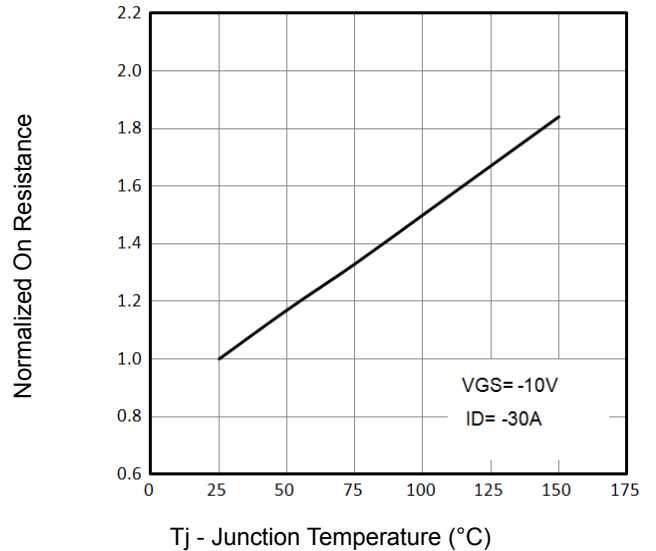

Fig4. Normalized On-Resistance Vs. T_j

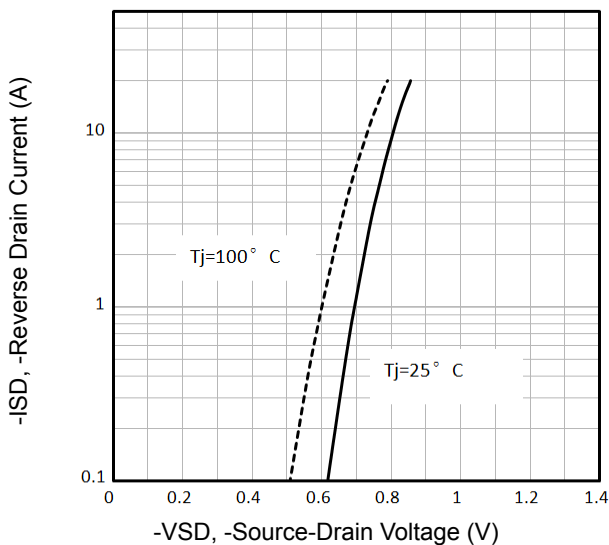

Fig5. Typical Source-Drain Diode Forward Voltage

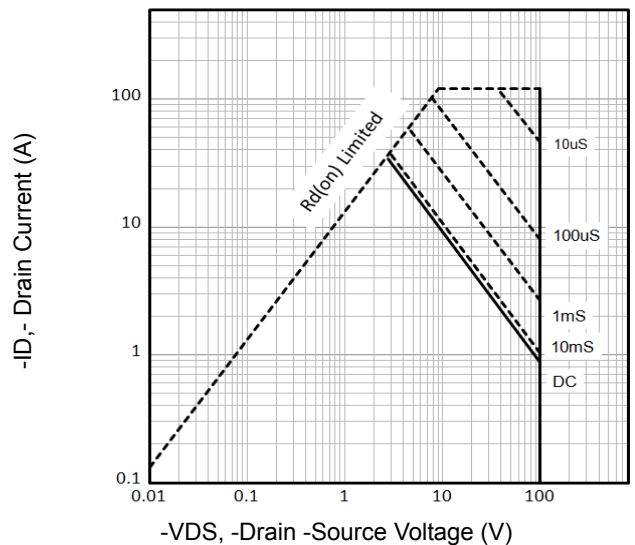

Fig6. Maximum Safe Operating Area

Typical Characteristics

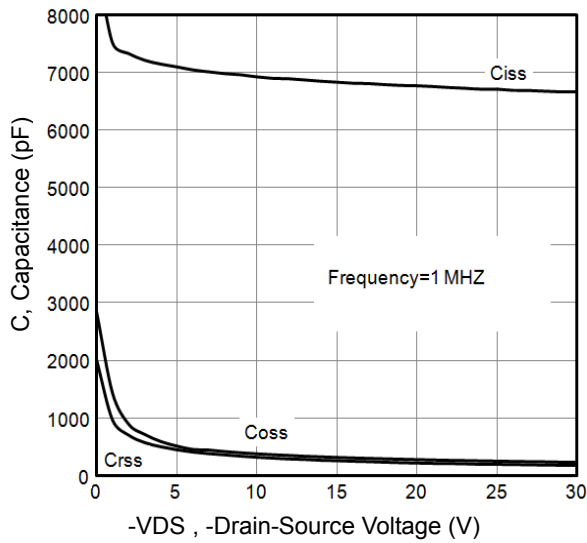

Fig7. Typical Capacitance Vs.Drain-Source Voltage

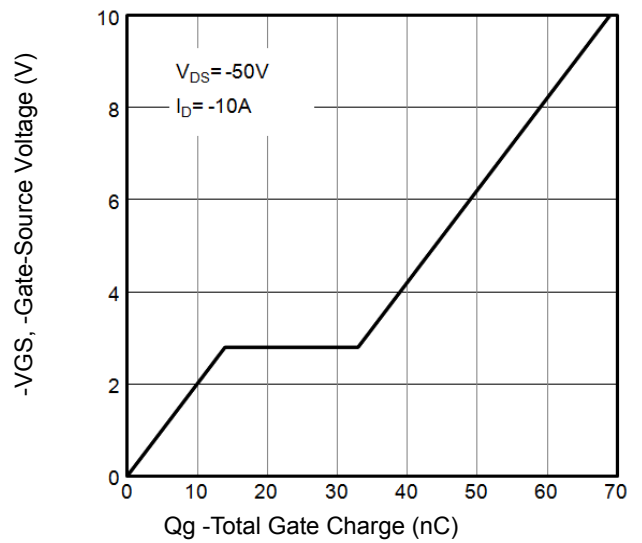

Fig8. Typical Gate Charge Vs.Gate-Source Voltage

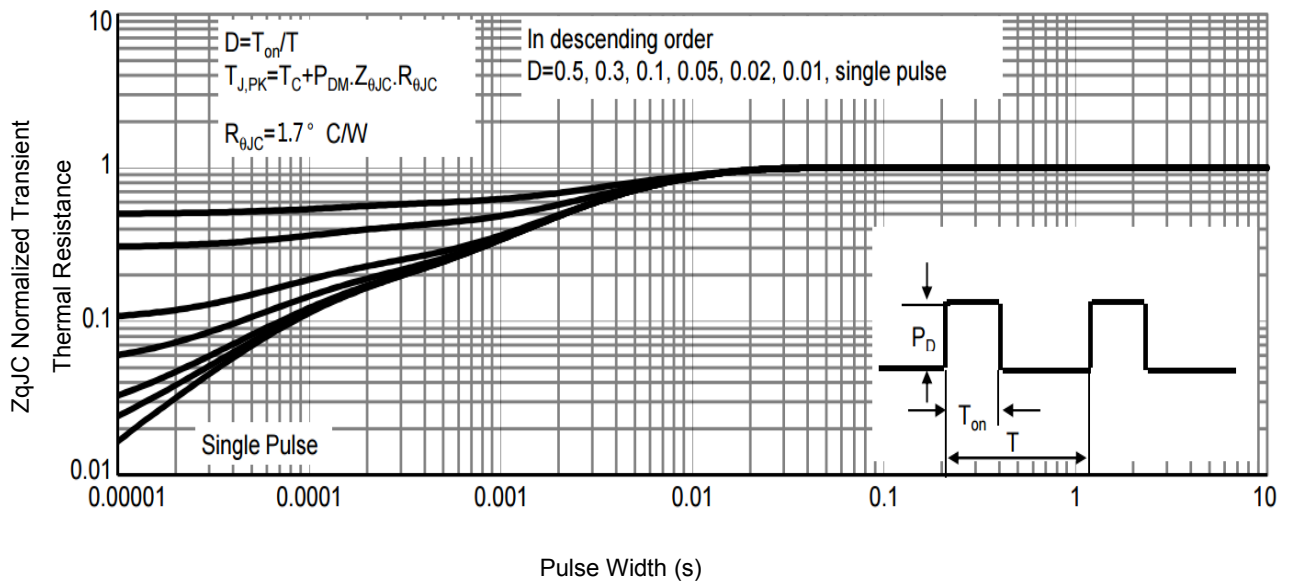

Fig9. Normalized Maximum Transient Thermal Impedance

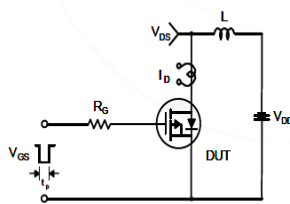

Fig10. Unclamped Inductive Test Circuit and Waveforms

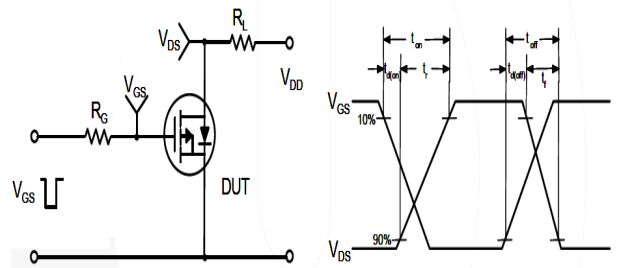
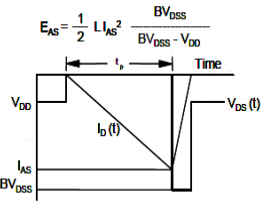
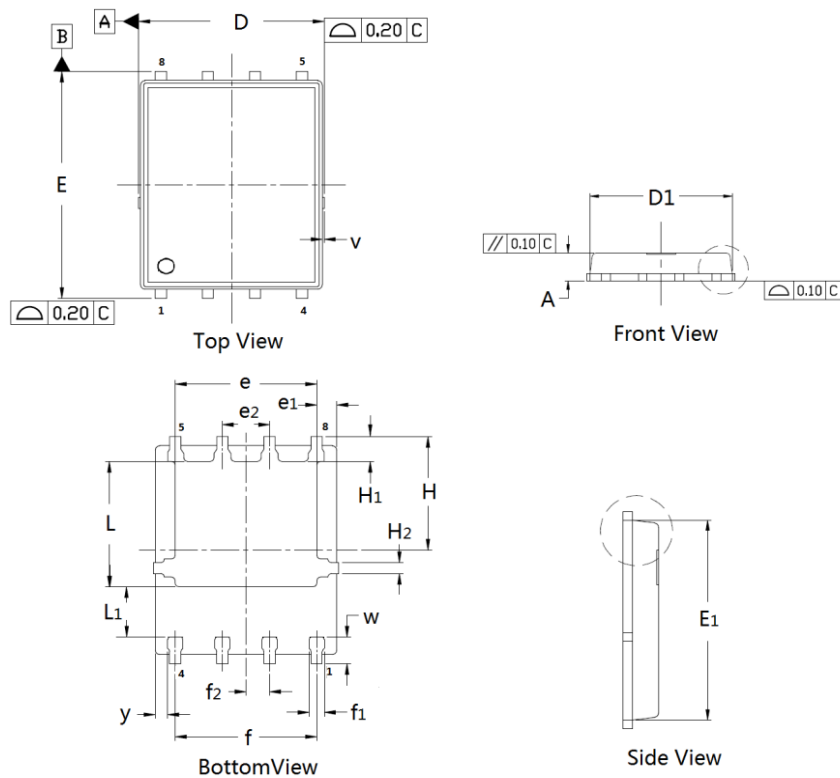

Fig11. Switching Time Test Circuit and waveforms

PDFN5×6 Package Outline Data



DIMENSIONS (unit : mm)

Symbol	Min	Typ	Max	Symbol	Min	Typ	Max
A	0.90	1.02	1.10	D	4.90	4.98	5.10
D ₁	4.80	4.89	5.00	E	6.00	6.11	6.20
E ₁	5.65	5.74	5.85	e	3.72	3.80	3.92
e ₁	--	0.54	--	e ₂	--	1.27	--
f	--	3.82	--	f ₁	0.31	0.37	0.51
f ₂	--	0.64	--	H	--	3.15	--
H ₁	0.59	0.63	0.79	H ₂	0.26	0.28	0.32
L	3.38	3.45	3.58	L ₁	--	1.39	--
v	--	0.13	--	w	0.64	0.68	0.84
y	--	0.34	--		--		--

Customer Service

Sales and Service:

sales@vgsemi.com

Vanguard Semiconductor CO., LTD

TEL: (86-755) -26902410

FAX: (86-755) -26907027

WEB: www.vgsemi.com