

Service Manual

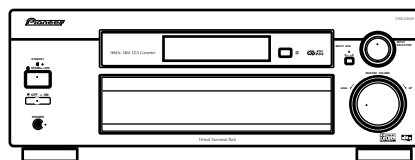

ORDER NO.
RRV2607

AUDIO/VIDEO MULTI-CHANNEL RECEIVER

VSX-D711-K

VSX-D711-S

THIS MANUAL IS APPLICABLE TO THE FOLLOWING MODEL(S) AND TYPE(S).

Model	Type	Power Requirement	Remarks
VSX-D711-K	MXJJI	AC230V	
VSX-D711-K	MYXJIEW	AC220-230V	
VSX-D711-K	MYXJIGR	AC220-230V	
VSX-D711-S	MYXJIEW	AC220-230V	



For details, refer to "Important symbols for good services" on page 3.

SAFETY INFORMATION



This service manual is intended for qualified service technicians; it is not meant for the casual do-it-yourselfer. Qualified technicians have the necessary test equipment and tools, and have been trained to properly and safely repair complex products such as those covered by this manual. Improperly performed repairs can adversely affect the safety and reliability of the product and may void the warranty. If you are not qualified to perform the repair of this product properly and safely, you should not risk trying to do so and refer the repair to a qualified service technician.



WARNING

This product contains lead in solder and certain electrical parts contain chemicals which are known to the state of California to cause cancer, birth defects or other reproductive harm.

Health & Safety Code Section 25249.6 – Proposition 65



NOTICE

(FOR CANADIAN MODEL ONLY)

Fuse symbols  (fast operating fuse) and/or  (slow operating fuse) on PCB indicate that replacement parts must be of identical designation.

REMARQUE

(POUR MODÈLE CANADIEN SEULEMENT)

Les symboles de fusible  (fusible de type rapide) et/ou  (fusible de type lent) sur CCI indiquent que les pièces de remplacement doivent avoir la même désignation.

(FOR USA MODEL ONLY)

1. SAFETY PRECAUTIONS

The following check should be performed for the continued protection of the customer and service technician.

LEAKAGE CURRENT CHECK

Measure leakage current to a known earth ground (water pipe, conduit, etc.) by connecting a leakage current tester such as Simpson Model 229-2 or equivalent between the earth ground and all exposed metal parts of the appliance (input/output terminals, screwheads, metal overlays, control shaft, etc.). Plug the AC line cord of the appliance directly into a 120V AC 60 Hz outlet and turn the AC power switch on. Any current measured must not exceed 0.5 mA.

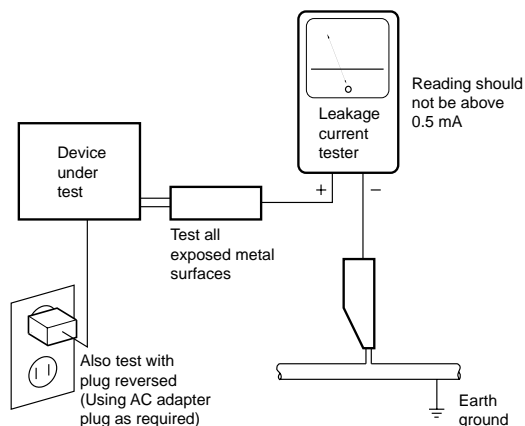

AC Leakage Test

ANY MEASUREMENTS NOT WITHIN THE LIMITS OUTLINED ABOVE ARE INDICATIVE OF A POTENTIAL SHOCK HAZARD AND MUST BE CORRECTED BEFORE RETURNING THE APPLIANCE TO THE CUSTOMER.

2. PRODUCT SAFETY NOTICE

Many electrical and mechanical parts in the appliance have special safety related characteristics. These are often not evident from visual inspection nor the protection afforded by them necessarily can be obtained by using replacement components rated for voltage, wattage, etc. Replacement parts which have these special safety characteristics are identified in this Service Manual.

Electrical components having such features are identified by marking with a Δ on the schematics and on the parts list in this Service Manual.

The use of a substitute replacement component which does not have the same safety characteristics as the PIONEER recommended replacement one, shown in the parts list in this Service Manual, may create shock, fire, or other hazards.

Product Safety is continuously under review and new instructions are issued from time to time. For the latest information, always consult the current PIONEER Service Manual. A subscription to, or additional copies of, PIONEER Service Manual may be obtained at a nominal charge from PIONEER.

[Important symbols for good services]

In this manual, the symbols shown-below indicate that adjustments, settings or cleaning should be made securely. When you find the procedures bearing any of the symbols, be sure to fulfill them:

1. Product safety



You should conform to the regulations governing the product (safety, radio and noise, and other regulations), and should keep the safety during servicing by following the safety instructions described in this manual.

2. Adjustments



To keep the original performances of the product, optimum adjustments or specification confirmation is indispensable. In accordance with the procedures or instructions described in this manual, adjustments should be performed.

3. Cleaning



For optical pickups, tape-deck heads, lenses and mirrors used in projection monitors, and other parts requiring cleaning, proper cleaning should be performed to restore their performances.

4. Shipping mode and shipping screws



To protect the product from damages or failures that may be caused during transit, the shipping mode should be set or the shipping screws should be installed before shipping out in accordance with this manual, if necessary.

5. Lubricants, glues, and replacement parts



Appropriately applying grease or glue can maintain the product performances. But improper lubrication or applying glue may lead to failures or troubles in the product. By following the instructions in this manual, be sure to apply the prescribed grease or glue to proper portions by the appropriate amount. For replacement parts or tools, the prescribed ones should be used.

CONTENTS

SAFETY INFORMATION	2
1. SPECIFICATIONS	5
2. EXPLODED VIEWS AND PARTS LIST	6
2.1 PACKING	6
2.2 EXTERIOR	8
2.3 FRONT PANEL	10
3. BLOCKDIAGRAM AND SCHEMATIC DIAGRAM	12
3.1 BLOCK DIAGRAM	12
3.2 OVERALL WIRING CONNECTION DIAGRAM	14
3.3 DD & INPUT ASSY(1/4)	16
3.4 DD & INPUT ASSY(2/4)	18
3.5 DD & INPUT ASSY(3/4)	20
3.6 DD & INPUT ASSY(4/4)	22
3.7 AMP & PRIMARY(1/2), TRANS2 and TRANS3 ASSYS	24
3.8 AMP & PRIMARY(2/2), REGULATOR, HASHIGETA B TO B , AMP INPUT and TRANS 1 ASSYS	26
3.9 DIGITAL IN ASSY	28
3.10 KAWA ASSY	29
3.11 VIDEO and 6CH IN ASSYS	30
3.12 S. VIDEO ASSY	31
3.13 FRONT, R. ENCODER and POWER SW ASSYS	32
3.14 FRONT VIDEO and H.P. ASSYS	34
3.15 TRANS4 and MECHA SW ASSYS	35
3.16 FM/AM TUNER MODULE	36
4. PCB CONNECTION DIAGRAM	38
4.1 TRANS1, TRANS2, TRANS3 and TRANS4 ASSYS	39
4.2 DD & INPUT ASSY	40
4.3 AMP & PRIMARY, AMP INPUT and MECHA SW ASSYS	44
4.4 REGULATOR, HASHIGETA and KAWA ASSYS	46
4.5 B TO B, DIGITAL IN, VIDEO and 6CH IN ASSYS	48
4.6 S. VIDEO and FRONT VIDEO ASSYS	50
4.7 FRONT, POWER SW, H.P. and R. ENCODER ASSYS	52
4.8 FM/AM TUNER MODULE	56
5. PCB PARTS LIST	57
6. ADJUSTMENT	63
7. GENERAL INFORMATION	64
7.1 DIAGNOSIS	64
7.1.1 U-COM BLOCKDIAGRAM	64
7.1.2 POWER ON AND OFF SEQUENCE	65
7.1.3 PROTECTION CIRCUIT	67
7.2.2 PCB LOCATION	68
7.2 PARTS	69
7.2.1 IC	69
7.2.2 DISPLAY	77
7.3 CLEANING	78
8. PANEL FACILITIES	79

1. SPECIFICATIONS

Amplifier Section

Continuous Power Output (STEREO mode)
 Front 100 W per channel (DIN 1kHz, THD 1.0 %, 8 Ω)

Continuous Power Output
 Front 100 W per channel (1kHz, THD 1.0 %, 8 Ω)
 Center 100 W (1kHz, THD 1.0 %, 8 Ω)
 Surround 100 W per channel (1kHz, THD 1.0 %, 8 Ω)

- Above specifications are applicable when the power supply is 230V.

Input (Sensitivity/Impedance)
 CD, VCR/DVR, CD-R/TAPE/MD, DVD/LD, TV/SAT ... 200 mV/47 kΩ

Frequency Response
 CD, VCR/DVR, CD-R/TAPE/MD, DVD/LD,
 TV/SAT 5 Hz to 100,000 Hz $^{+0}_{-3}$ dB

Output (Level/Impedance)
 VCR/DVR REC, CD-R/TAPE/MD REC 200 mV/2.2 kΩ

Tone Control
 BASS ± 6 dB (100 Hz)
 TREBLE ± 6 dB (10 kHz)
 LOUDNESS +9 dB/+9 dB (100 Hz/10 kHz)

Signal-to-Noise Ratio [DIN (Continuous rated power output/50 mW)]
 CD, VCR/DVR, CD-R/TAPE/MD, DVD/LD, TV/SAT 96 dB

Video Section

Input (Sensitivity/Impedance)
 VCR/DVR, DVD/LD, TV/SAT 1 Vp-p/75 Ω

Output (Level/Impedance)
 VCR/DVR 1 Vp-p/75 Ω

Frequency Response
 VCR/DVR, DVD/LD, TV/SAT ⇒ MONITOR 5 Hz to 7 MHz $^{+0}_{-3}$ dB
 Signal-to-Noise Ratio 55 dB

Manufactured under license from Dolby Laboratories.
 "Dolby", "Pro Logic" and the double D symbol are trademarks of Dolby Laboratories.

"DTS", "DTS-ES Extended Surround" and "Neo:6" are trademarks of Digital Theater Systems, Inc.

FM Tuner Section

Frequency Range 87.5 MHz to 108 MHz
 Usable Sensitivity Mono:13.2 dBf, IHF (1.3 μV/ 75 Ω)
 50 dB Quieting Sensitivity Mono: 20.2 dB
 Stereo: 38.6 dBf
 Signal-to-Noise Ratio Mono: 73 dB (at 85 dBf)
 Stereo: 70 dB (at 85 dBf)
 Signal-to-Noise Ratio (DIN) Mono: 62 dB
 Stereo: 58 dB
 Distortion Stereo: 0.5 % (1 kHz)
 Alternate Channel Selectivity 60 dB (400 kHz)
 Stereo Separation 40 dB (1 kHz)
 Frequency Response 30 Hz to 15 kHz (±1 dB)
 Antenna Input (DIN) 75 Ω unbalanced

AM Tuner Section

Frequency Range 531 kHz to 1,602 kHz
 Sensitivity (IHF, Loop antenna) 350 μV/m
 Selectivity 25 dB
 Signal-to-Noise Ratio 50 dB
 Antenna Loop antenna

Miscellaneous

Power Requirements
 UK model AC 230 V, 50/60 Hz
 European model AC 220-230 V, 50/60 Hz
 Power Consumption
 VSX-D711 250W
 In Standby 1 W
 Dimensions 420 (W) x 158 (H) x 401 (D) mm
 Weight (without package) 10 kg

Furnished Parts

AM loop antenna 1
 FM wire antenna 1
 Dry cell batteries (AA size IEC R6P) 2
 Remote control 1
 Operating instructions 1

 **Note**
 Specifications and the design are subject to possible modifications without notice, due to improvements.

Accessories

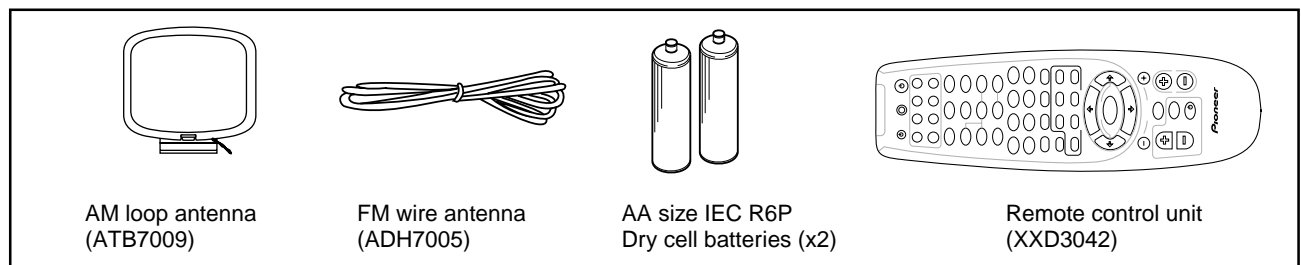

AM loop antenna (ATB7009)

FM wire antenna (ADH7005)

AA size IEC R6P Dry cell batteries (x2)

Remote control unit (XXD3042)

2. EXPLODED VIEWS AND PARTS LIST

- NOTES:
- Parts marked by "NSP" are generally unavailable because they are not in our Master Spare Parts List.
 - The \triangle mark found on some component parts indicates the importance of the safety factor of the part. Therefore, when replacing, be sure to use parts of identical designation.
 - Screws adjacent to \blacktriangledown mark on product are used for disassembly.
 - For the applying amount of lubricants or glue, follow the instructions in this manual.
(In the case of no amount instructions, apply as you think it appropriate.)

2.1 PACKING

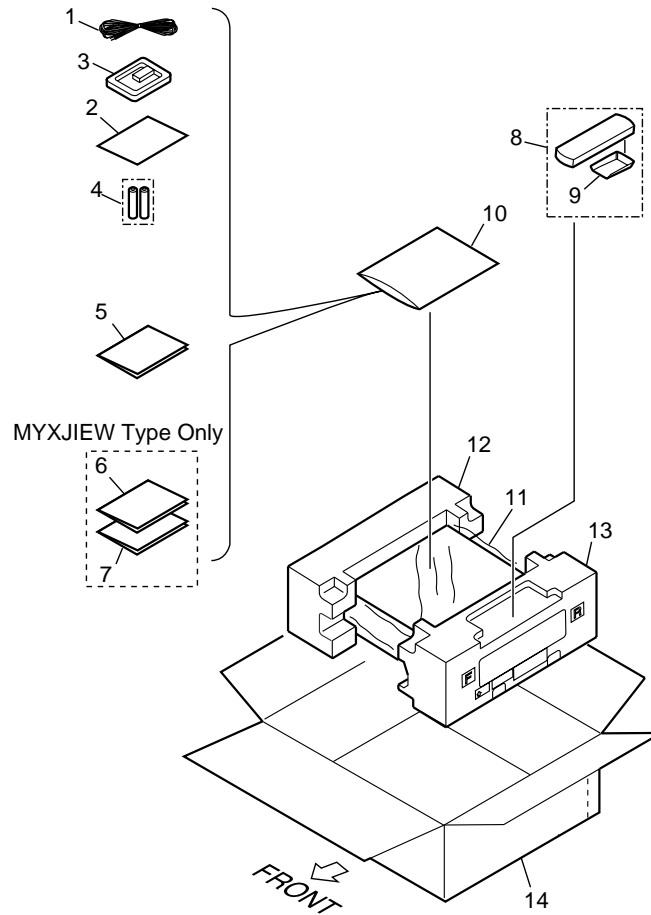

(1) PACKING PARTS LIST

Mark	No.	Description	Part No.
NSP	1	FM Wire Antenna	ADH7005
	2	Warranty Card	ARY7022
	3	AM Loop Antenna	ATB7009
NSP	4	Dry Cell Batteries(AA/R6P)	VEM-013
	5	Operating Instructions (English/German)	XRE3059
	6	Operating Instructions (French/Italian)	See Contrast table (2)
	7	Operating Instructions (Dutch/Spanish)	See Contrast table (2)
	8	Remote Control	XXD3042
	9	Battery Cover	XZA3002
NSP	10	Polyethylene Bag	Z21-038
	11	Packing Sheet	AHG7069
	12	Left Pad R5	XHA3032
	13	Right Pad R5	XHA3033
	14	Packing Case	See Contrast table (2)

(2) CONTRAST TABLE

VSX-D711-K/MVXJI, /MYXJIEW, /MYXJIGR and VSX-D711-S/MYXJIEW are constructed the same except for the following:

Mark	No.	Symbol and Description	Part No.				Remarks
			VSX-D711-K /MVXJI	VSX-D711-K /MYXJIEW	VSX-D711-K /MYXJIGR	VSX-D711-S /MYXJIEW	
	6	Operating Instructions(French/Italian)	Not used	XRC3060	Not used	XRC3060	
	7	Operating Instructions(Dutch/Spanish)	Not used	XRC3071	Not used	XRC3071	
	14	Packing Case	XHD3206	XHD3206	XHD3206	XHD3294	

2.2 EXTERIOR

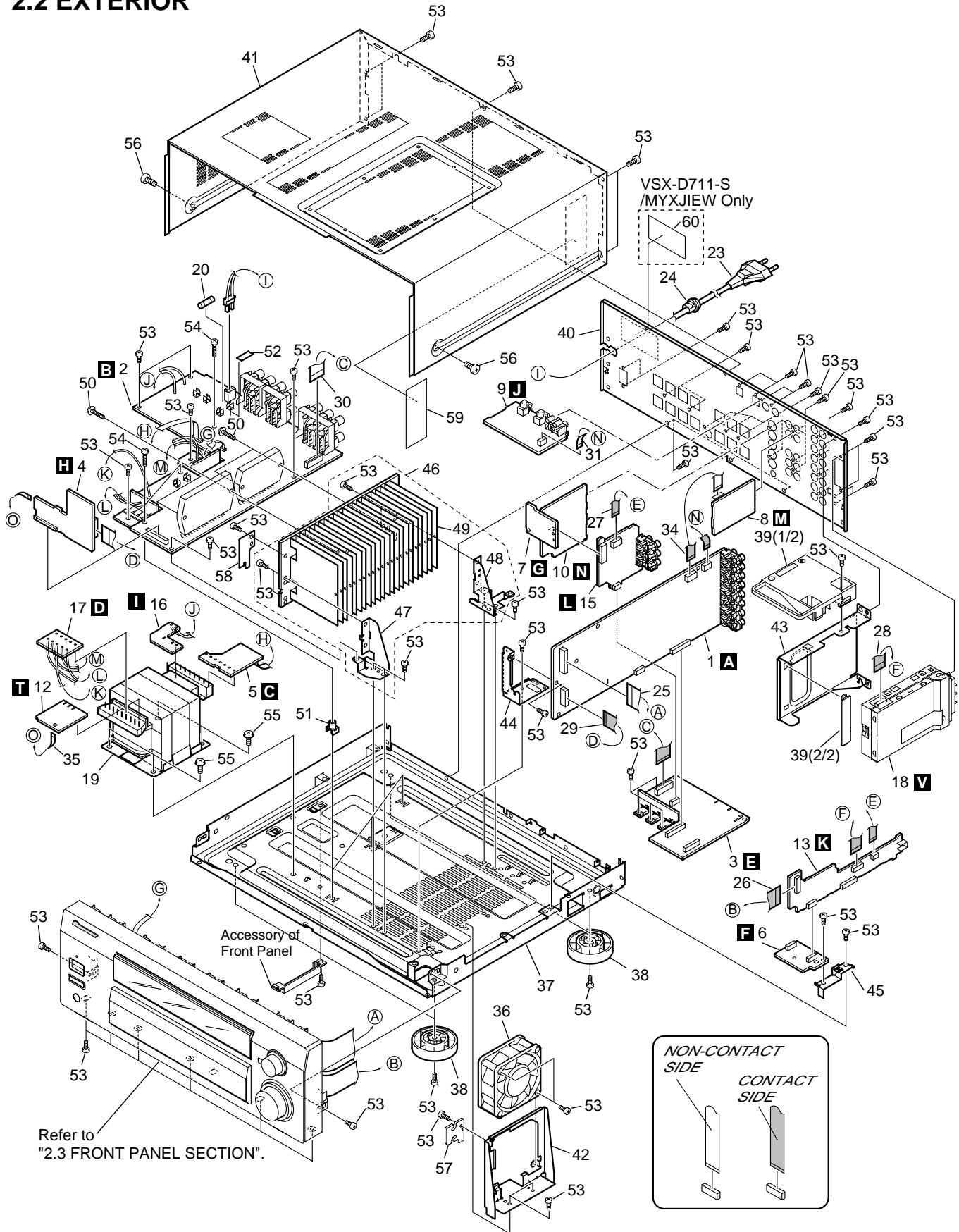

(1) EXTERIOR PARTS LIST

Mark	No.	Description	Part No.	Mark	No.	Description	Part No.	
	1	D.D & INPUT ASSY	XWX3047		31	7P F•F•C/30V (J37) (DD&INPUT CN9101 – DIGITAL IN CN1901)	XDD3103	
	2	AMP&PRIMARY ASSY	XWZ3537		32	•••••		
	3	REGULATOR ASSY	XWZ3545		33	•••••		
	4	AMP INPUT ASSY	XWZ3550		34	9P F•F•C/30V (J48) (DD&INPUT CN104 – 6CH IN CN307)	XDD3106	
	5	TRANS2 ASSY	XWZ3558		35	3P F•F•C/30V (J22) (AMP INPUT CN251 – TRANS4 CN891)	XDD3107	
	6	HASHIGETA ASSY	XWZ3567		△	36	Fan Motor	XXM3002
	7	BOARD TO BOARD ASSY	XWZ3575	NSP	37	Under Base 409	ANA7094	
	8	6CH IN ASSY	XWZ3507		38	Insulator	PNW2766	
	9	DIGITAL IN ASSY	XWZ3518		39	FFC Cover R5	XMR3047	
	10	S. VIDEO ASSY	XWZ3522		40	Rear Panel 711/MY	XNC3144	
	11	•••••			41	Bonnet D510	See Contrast table (2)	
	12	TRANS4 ASSY	XWZ3526		42	Fan Holder R4	XNG3040	
	13	KAWA ASSY	XWZ3529		43	Tuner Shield R5	XNG3072	
	14	•••••			44	PCB Angle R5	XNG3073	
	15	VIDEO ASSY	XWZ3584		45	Reg Support R5	XNG3074	
NSP	16	TRANS1 ASSY	XWZ3553	NSP	46	Heat Sink Assy 0.4*40	XNH3023	
NSP	17	TRANS3 ASSY	XWZ3561		47	Heat Sink Angle F	ANG7251	
	18	FM/AM TUNER MODULE	AXQ7232		48	Heat Sink Angle R	ANG7252	
△	19	Power Transformer (T1)	XTS3046		49	Heat Sink	XNH3022	
△	20	FU1(T2.5A)	REK1026		50	Screw 3x23	ABA7043	
	21	•••••		NSP	51	PCB Mold	AMR2533	
	22	•••••			52	Fuse Card	AAAX7277	
△	23	AC Power Cord	See Contrast table (2)		53	Screw	BBZ30P080FMC	
	24	Cord Stopper	CM-22B		54	Screw	BBZ30P200FMC	
	25	28P F•F•C/30V (J31) (DD&INPUT CN102 – FRONT CN402)	XDD3097		55	Screw	FBT40P080FZK	
	26	17P F•F•C/30V (J32) (KAWA CN5001 – FRONT CN401)	XDD3098	NSP	56	Screw	See Contrast table (2)	
	27	7P F•F•C/30V (J33) (KAWA CN5004 – VIDEO CN503)	XDD3099	NSP	57	Binder Assy	XWZ3571	
	28	13P F•F•C/30V (J34) (KAWA CN5005 – FM/AM TUNER CN201)	XDD3100	NSP	58	Holder Assy	XWZ3574	
	29	19P F•F•C/30V (J35) (DD&INPUT CN106 – AMP INPUT CN254)	XDD3101	NSP	59	Tuner Sheet MY	XEC3031	
	30	23P F•F•C/30V (J36) (AMP&PRIMARY CN53 – REGULATOR CN801)	XDD3102	NSP	60	N Label 711S/MY	See Contrast table (2)	

(2) CONTRAST TABLE

VSX-D711-K/MVXJI, /MYXJIEW, /MYXJIGR and VSX-D711-S/MYXJIEW are constructed the same except for the following:

Mark	No.	Symbol and Description	Part No.				Remarks
			VSX-D711-K /MVXJI	VSX-D711-K /MYXJIEW	VSX-D711-K /MYXJIGR	VSX-D711-S /MYXJIEW	
△	23	AC Power Code	VDG1076	VDG1077	VDG1077	VDG1077	
	41	Bonnet D510	XZN3112	XZN3112	XZN3112	XZN3122	
	56	Screw (for Bonnet)	FBT40P080FZK	FBT40P080FZK	FBT40P080FZK	FBT40P080FNI	
NSP	60	N Label 711S/MY	Not used	Not used	Not used	XAL3112	

2.3 FRONT PANEL

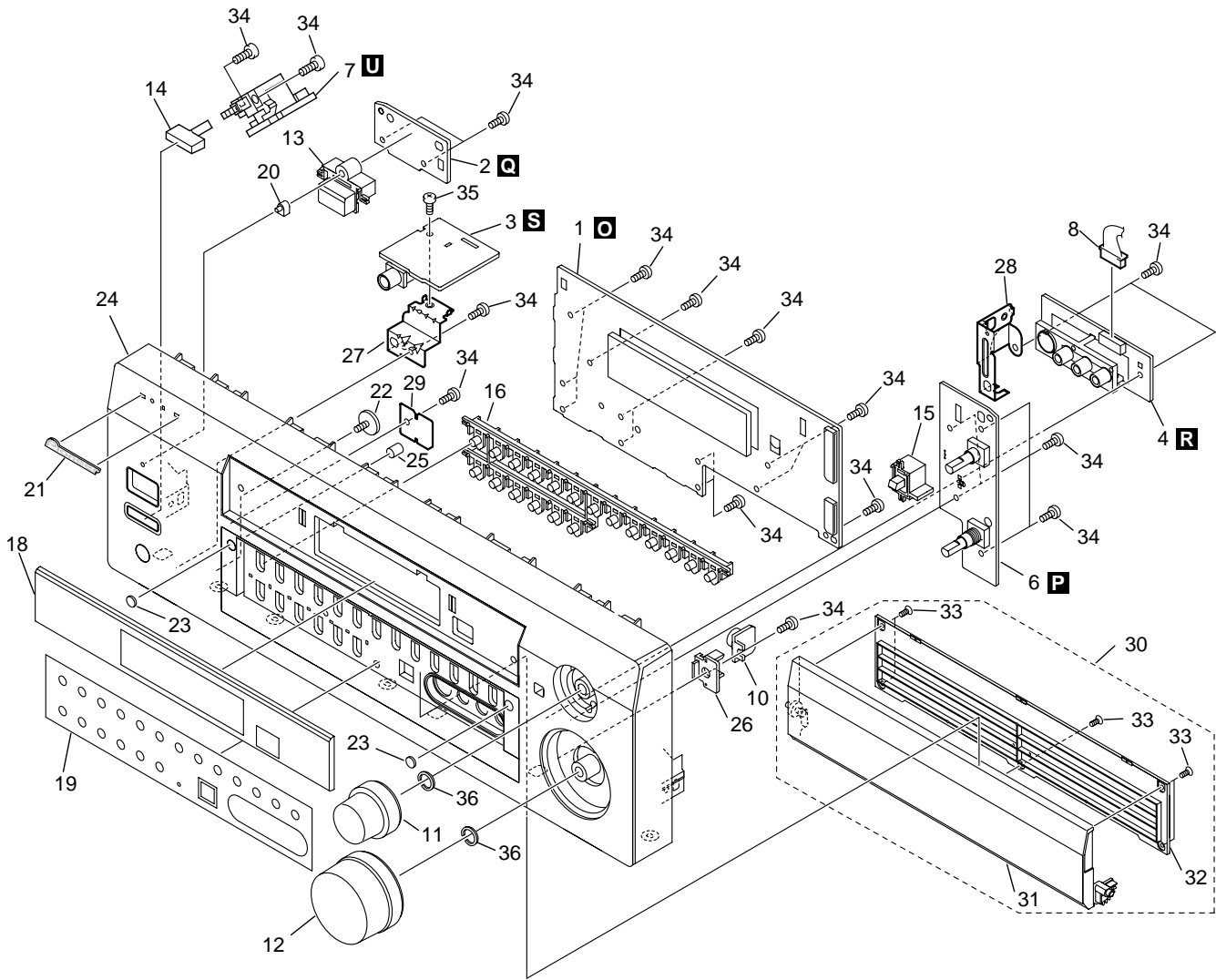

(1) FRONT PANEL PARTS LIST

Mark	No.	Description	Part No.	Mark	No.	Description	Part No.
	1	FRONT ASSY	XWZ3498		21	Pioneer Badge	See Contrast table (2)
	2	POWER SW ASSY	XWZ3510		22	Screw DR 3x8W	XBA3010
	3	H.P. ASSY	XWZ3513		23	Cushion R4	See Contrast table (2)
	4	FRONT VIDEO ASSY	XWZ3515		24	Front Panel 711	See Contrast table (2)
	5	•••••			25	Magnet R5	XMF3002
	6	R. ENCODER ASSY	XWZ3511		26	Holder L R5	XMR3046
	7	MECHA SW ASSY	XWZ3514		27	Earth Plate R5 HP	XNG3066
NSP	8	8P Shielded Cable (J29)	XDX3012		28	Earth Plate R5 D	XNG3067
	9	•••••			29	Magnet Cover R5	XNG3075
	10	Damper Assy	AXA7052		30	Door Assy R5	See Contrast table (2)
	11	Select Knob R5	See Contrast table (2)	NSP	31	Door R5	See Contrast table (2)
	12	Volume Knob R5	See Contrast table (2)	NSP	32	Door Cover R5	See Contrast table (2)
	13	Power Button R5	See Contrast table (2)	NSP	33	Screw 2x35	See Contrast table (2)
	14	Power Button R5M	See Contrast table (2)		34	Screw	PPZ30P080FMC
	15	Jog Button R5	See Contrast table (2)		35	Screw	BBZ30P080FMC
	16	Door Button R5	See Contrast table (2)	NSP	36	C Ring DIM8.1	XBH3016
	17	•••••					
	18	D Panel R5 W/MY	XAK3320				
	19	BN Cover 711/MY	See Contrast table (2)				
	20	LED Lens 1.6	XAK3308				

(2) CONTRAST TABLE

VSX-D711-K/MVXJI, /MYXJIEW, /MYXJIGR and VSX-D711-S/MYXJIEW are constructed the same except for the following:

Mark	No.	Symbol and Description	Part No.				Remarks
			VSX-D711-K /MVXJI	VSX-D711-K /MYXJIEW	VSX-D711-K /MYXJIGR	VSX-D711-S /MYXJIEW	
	11	Select Knob R5	XAB3023	XAB3023	XAB3023	XAB3024	
	12	Volume Knob R5	XAB3025	XAB3025	XAB3025	XAB3026	
	13	Power Button R5	XAD3123	XAD3123	XAD3123	XAD3129	
	14	Power Button R5M	XAD3127	XAD3127	XAD3127	XAD3137	
	15	Jog Button R5	XAD3124	XAD3124	XAD3124	XAD3131	
	16	Door Button R5	XAD3126	XAD3126	XAD3126	XAD3135	
	19	BN Cover 711/MY	XAK3291	XAK3291	XAK3291	XAK3284	
	21	Pioneer Badge	XAM3006	XAM3006	XAM3006	VAM1129	
	23	Cushion R4B	XED3001	XED3001	XED3001	Not used	
	23	Cushion R5S	Not used	Not used	Not used	XED3003	
	24	Front Panel 711	XMB3066	XMB3066	XMB3066	XMB3071	
	30	Door Assy R5	XXG3091	XXG3091	XXG3091	XXG3093	
NSP	31	Door R5	XAK3275	XAK3275	XAK3275	XAK3281	
NSP	32	Door Cover R5	XAK3276	XAK3276	XAK3276	XAK3283	
NSP	33	Screw 2x35	XBA3007	XBA3007	XBA3007	XBA3008	

3. BLOCKDIAGRAM AND SPECIFICATIONS

3.1 BLOCKDIAGRAM

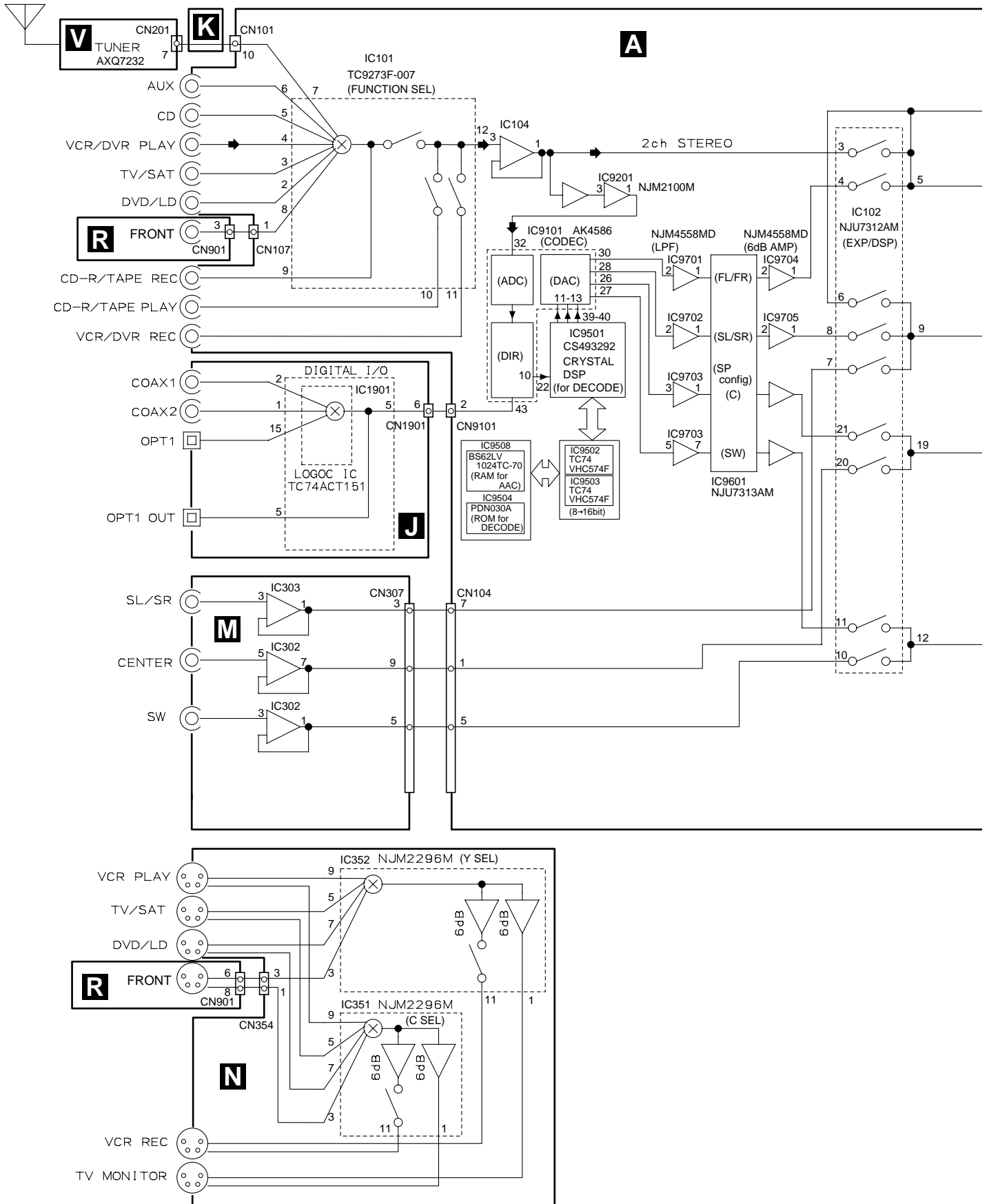

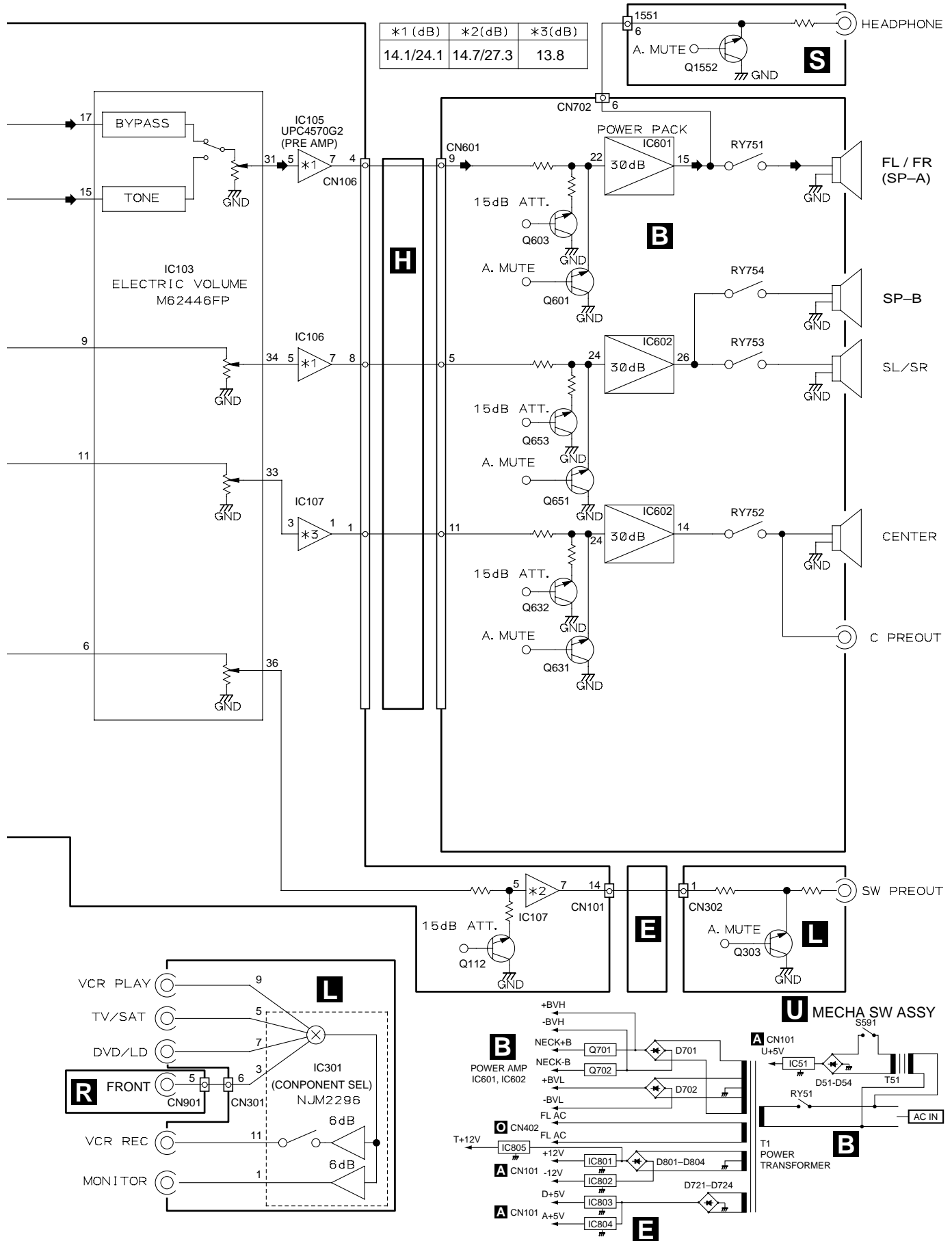

VSX-D711-K, VSX-D711-S

3.2 OVERALL WIRING CONNECTION DIAGRAM

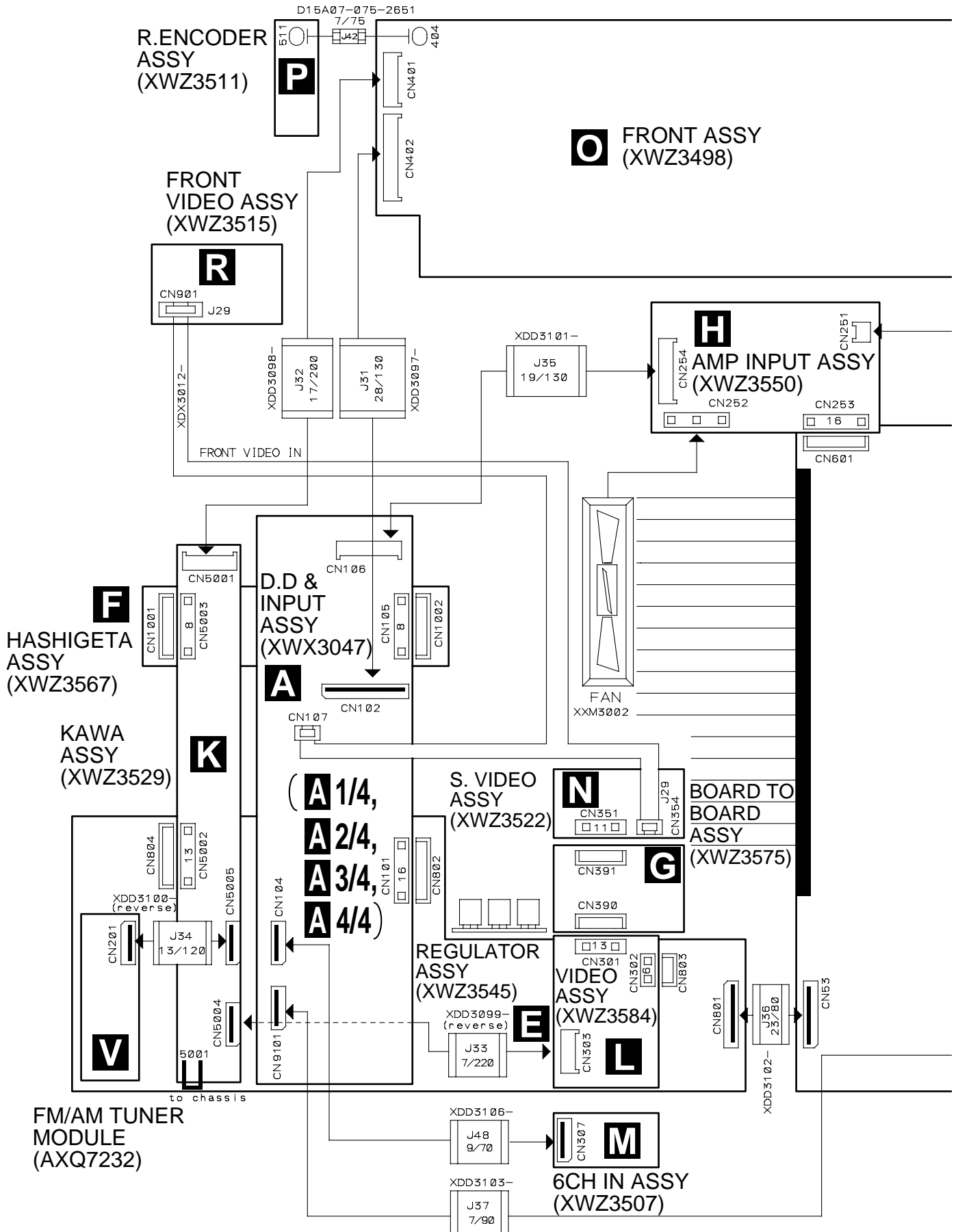

Note : When ordering service parts, be sure to refer to "EXPLODED VIEWS and PARTS LIST" or "PCB PARTS LIST".

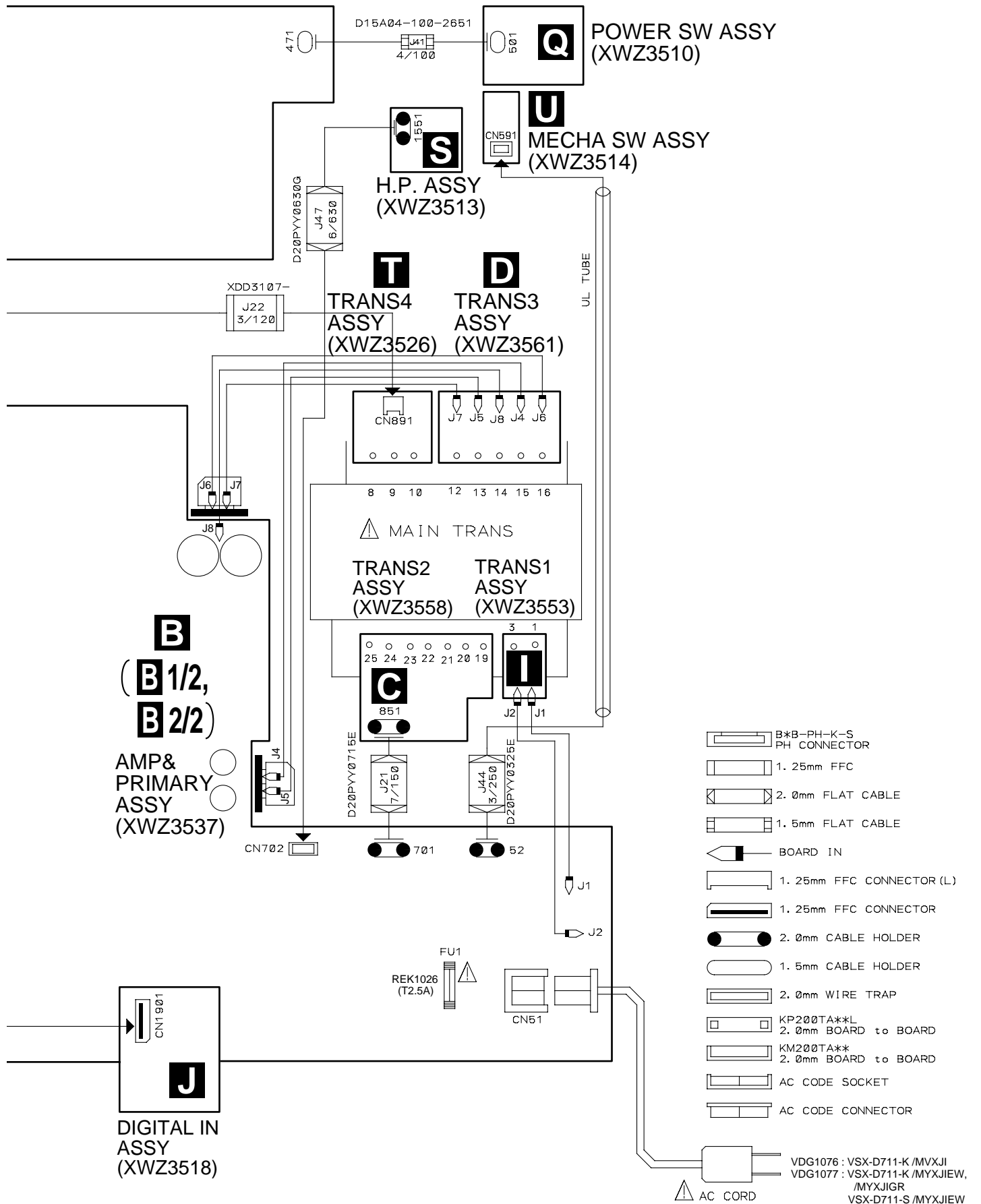

VSX-D711-K, VSX-D711-S

3.3 DD & INPUT ASSY(1/4)

A 1/4 D.D & INPUT ASSY (XWX3047)

TO CODEC & PRE AMP BLOCK

A

B

C

D

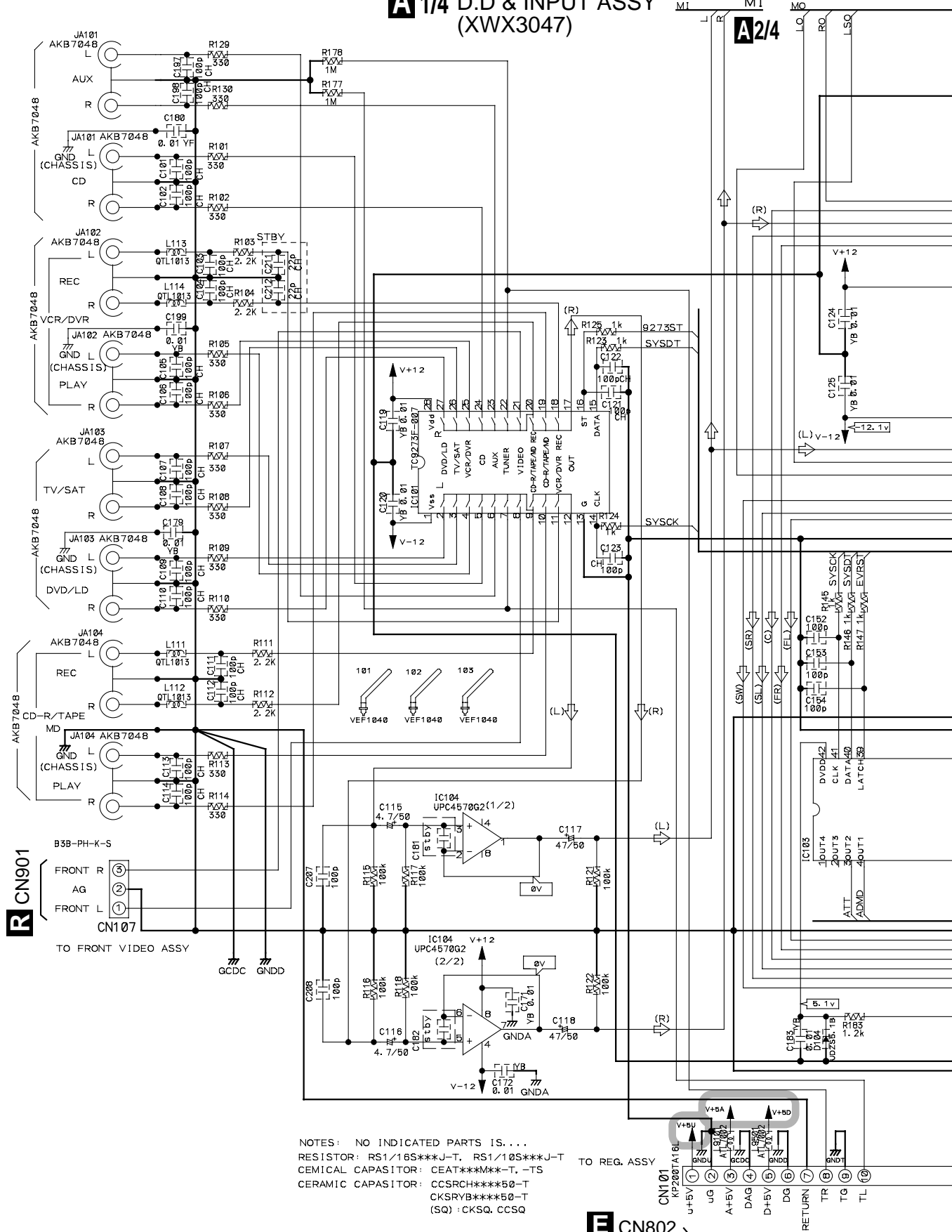

NOTES: NO INDICATED PARTS IS...
 RESISTOR: RS1/16S***J-T, RS1/10S***J-T
 CEMICAL CAPASITOR: CEAT***M***-T, -TS
 CERAMIC CAPASITOR: CCSRCH***50-T
 CKSRYB***50-T
 (SQ) : CKSQ, CCSQ

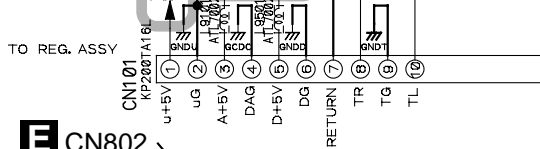

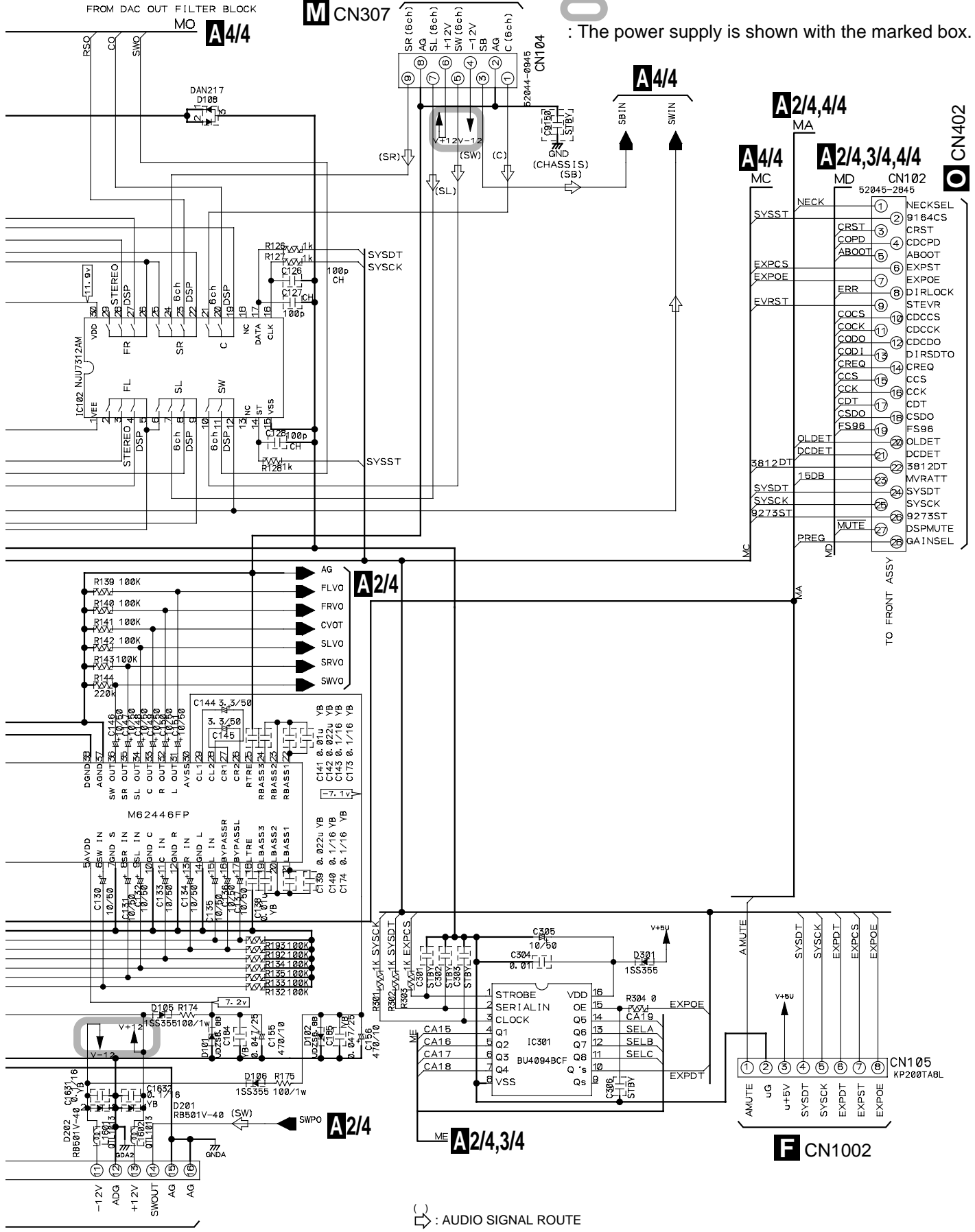

The power supply is shown with the marked box.

: AUDIO SIGNAL ROUTE

CN402

MA	1	NECKSEL	9184CS
	2	CRST	
	3	CDCPD	
	4	ABOOT	
	5	EXPST	
	6	DIRLOCK	
	7	STEVVR	
	8	CCDCS	
	9	CCDCCK	
	10	CCDCDO	
	11	DIRSDTO	
	12	CREQ	
	13	CCS	
	14	CCK	
	15	CDT	
	16	CSDO	
	17	FS96	
	18	OLDET	
	19	DCDET	
	20	3812DT	
	21	MVRATT	
	22	SYSDT	
	23	SYSCK	
	24	9273ST	
	25	SYSCMUTE	
	26	DSPMUTE	
	27	GAINSEL	
	28		

3.4 DD & INPUT ASSY(2/4)

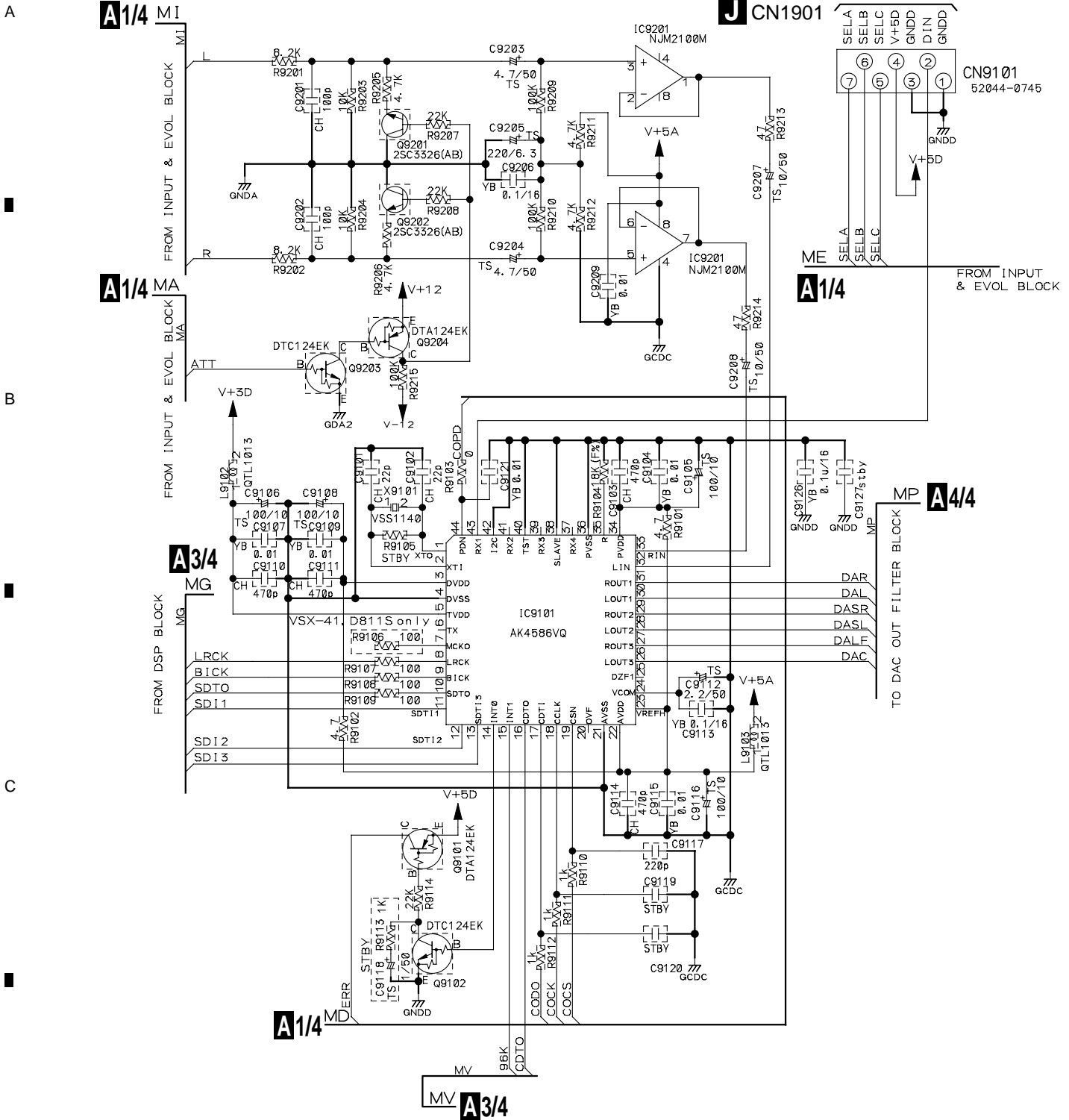

A 2/4 D.D & INPUT ASSY (XWX3047)

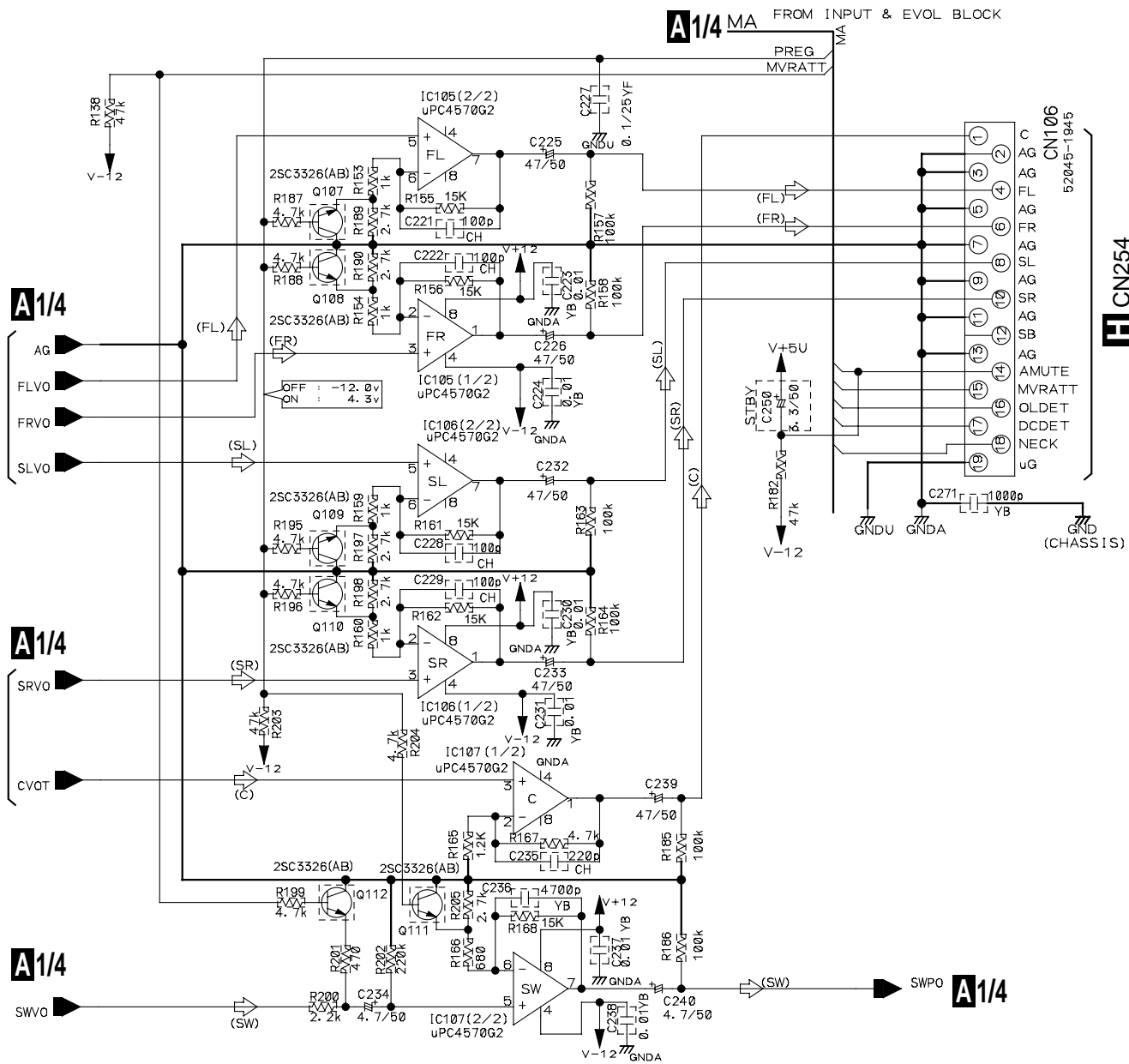

↪ : AUDIO SIGNAL ROUTE

	FRONT SURROUND	SW	CENTER
GAIN (dB)	14.1 / 24.1	14.7 / 27.3	13.8

VSX-D711-K, VSX-D711-S

3.5 DD & INPUT ASSY(3/4)

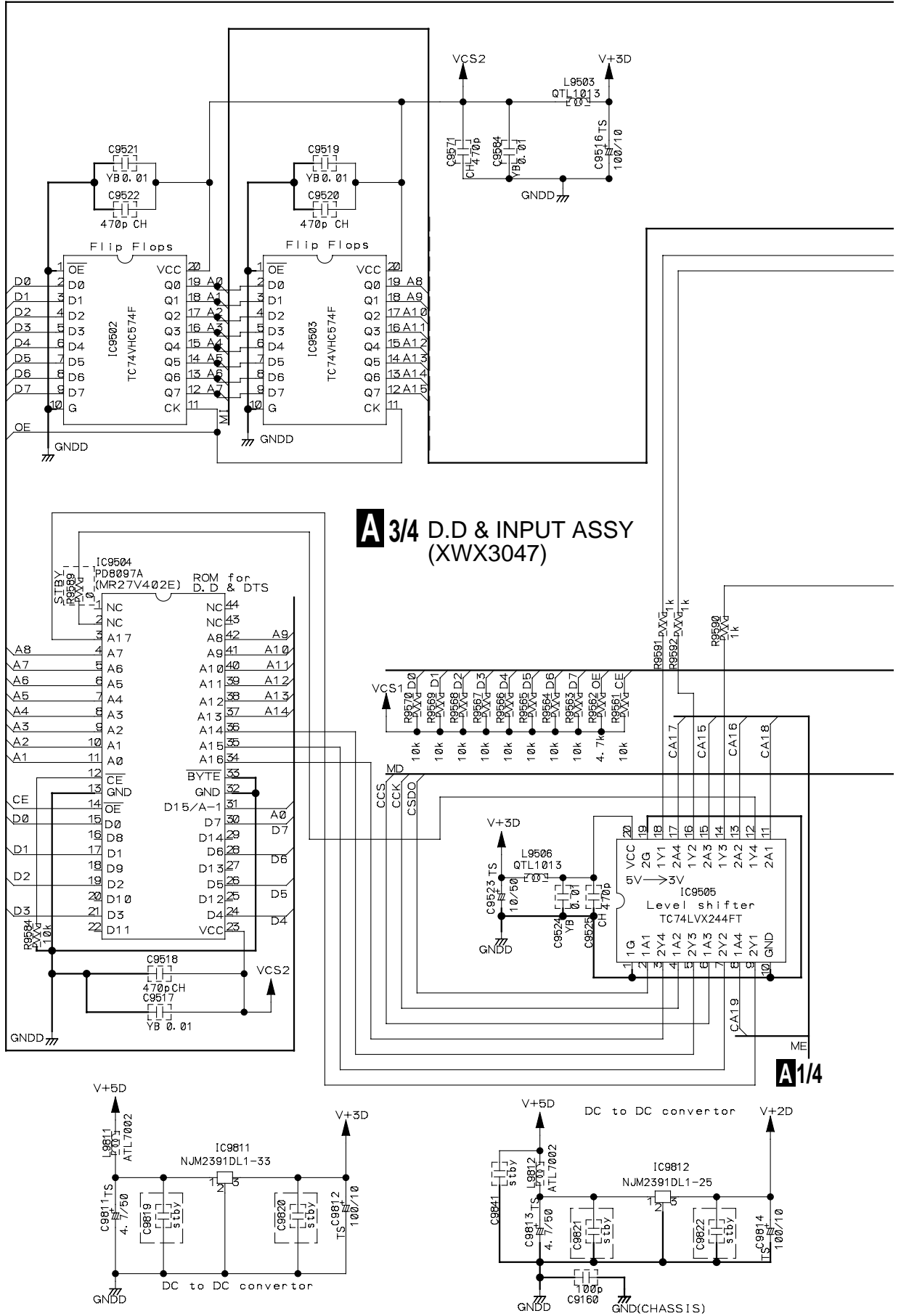

VSX-D711-K, VSX-D711-S

Main DSP 1 decodes D.D and DTS signals.

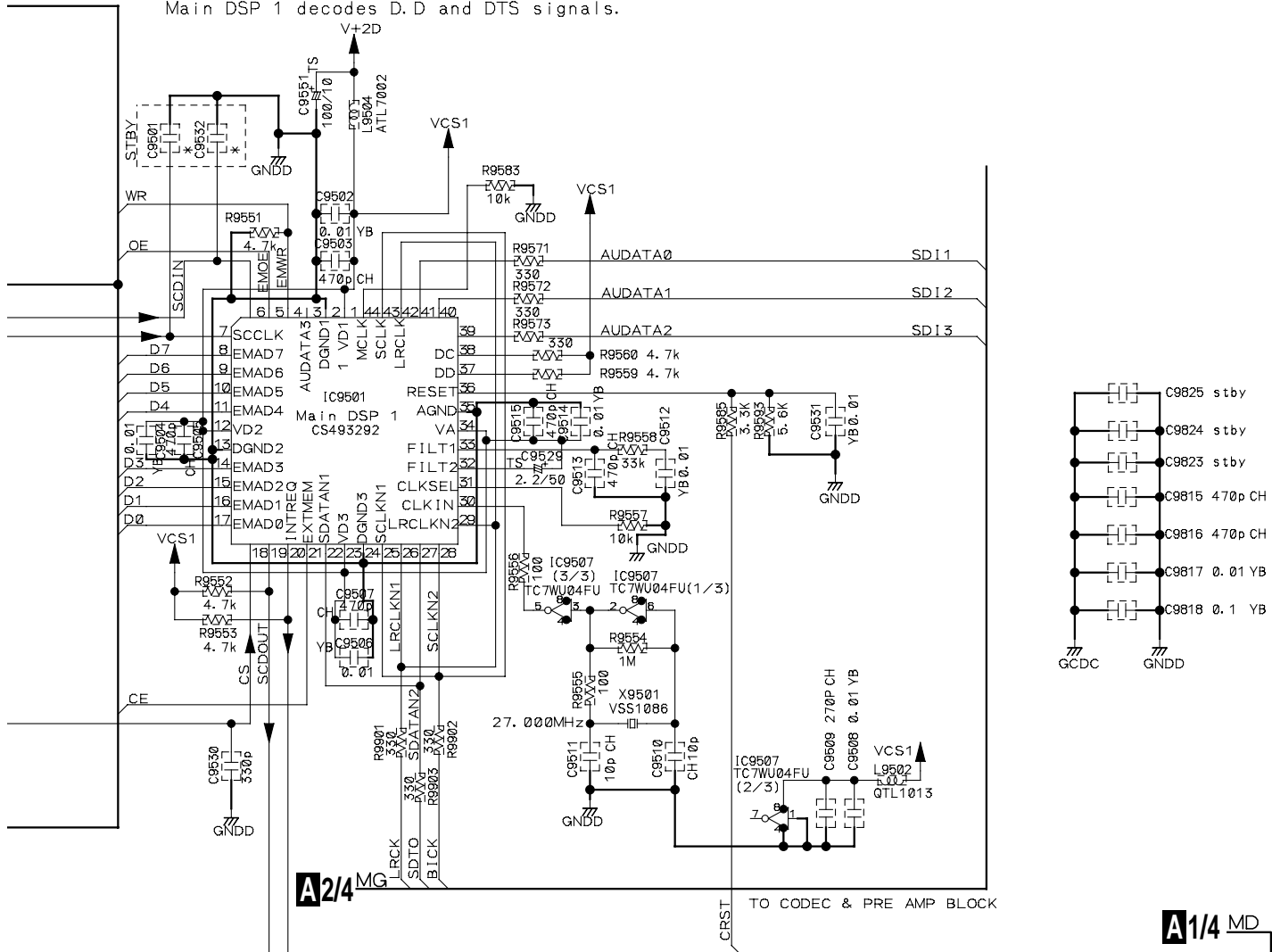

A2/4 MG

A1/4 MD

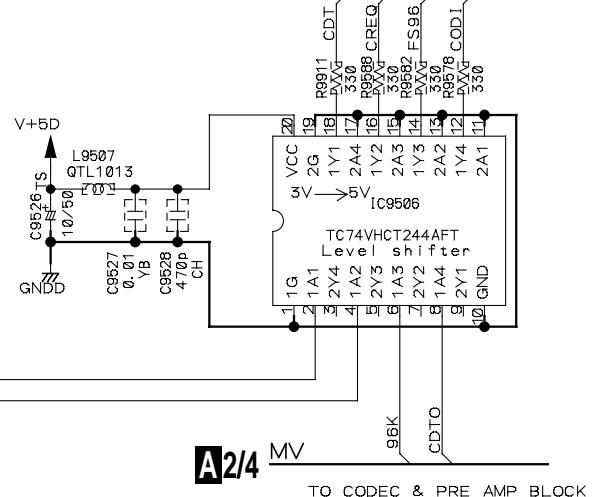

A2/4 MV

TO CODEC & PRE AMP BLOCK

A 3/4 21

VSX-D711-K, VSX-D711-S

3.6 DD & INPUT ASSY(4/4)

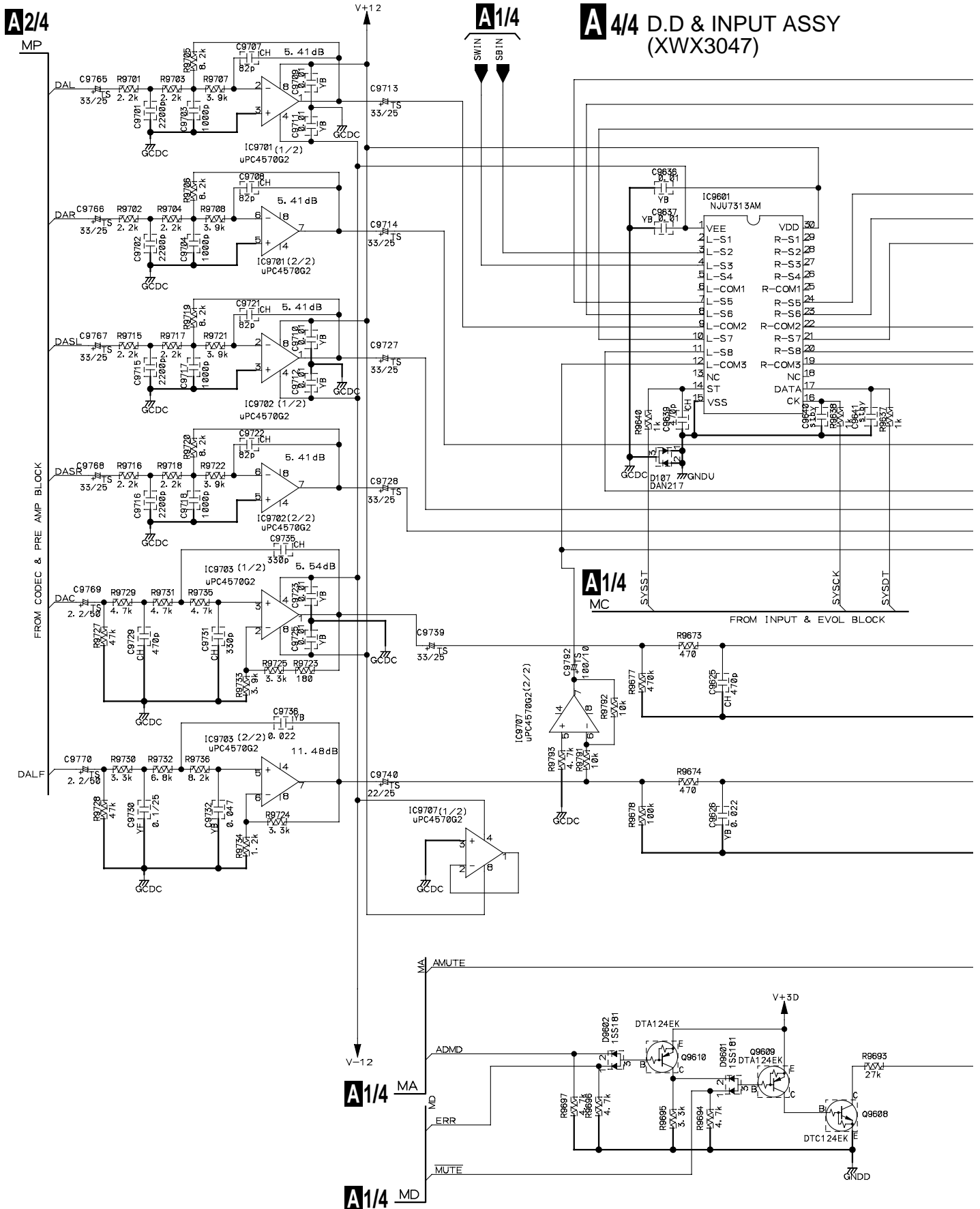

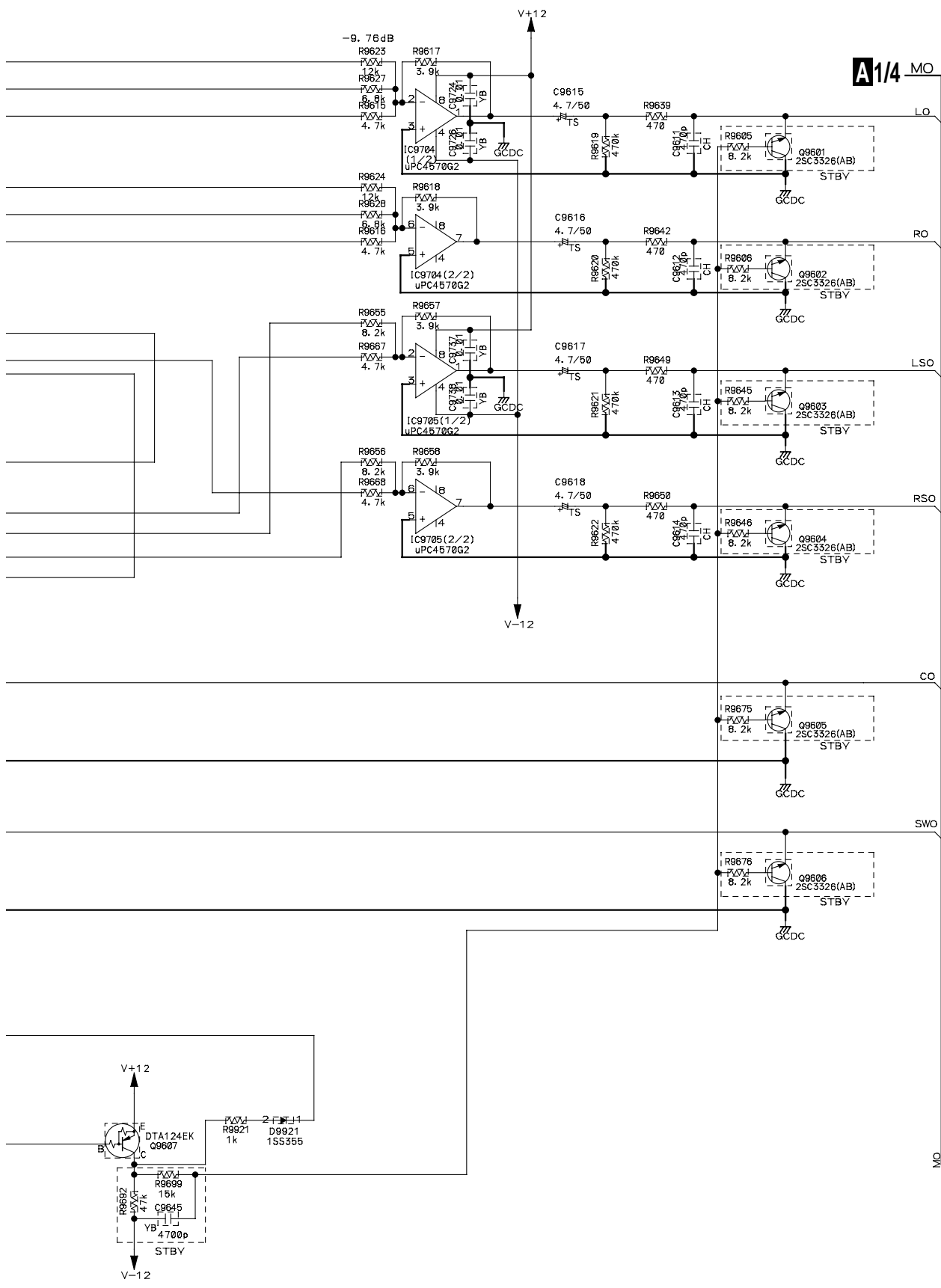

A 1/4 MO

TO INPUT & EVOL BLOCK

3.7 AMP & PRIMARY(1/2), TRANS2 and TRANS3 ASSYS

B 1/2 AMP&PRIMARY ASSY (XWZ3537)

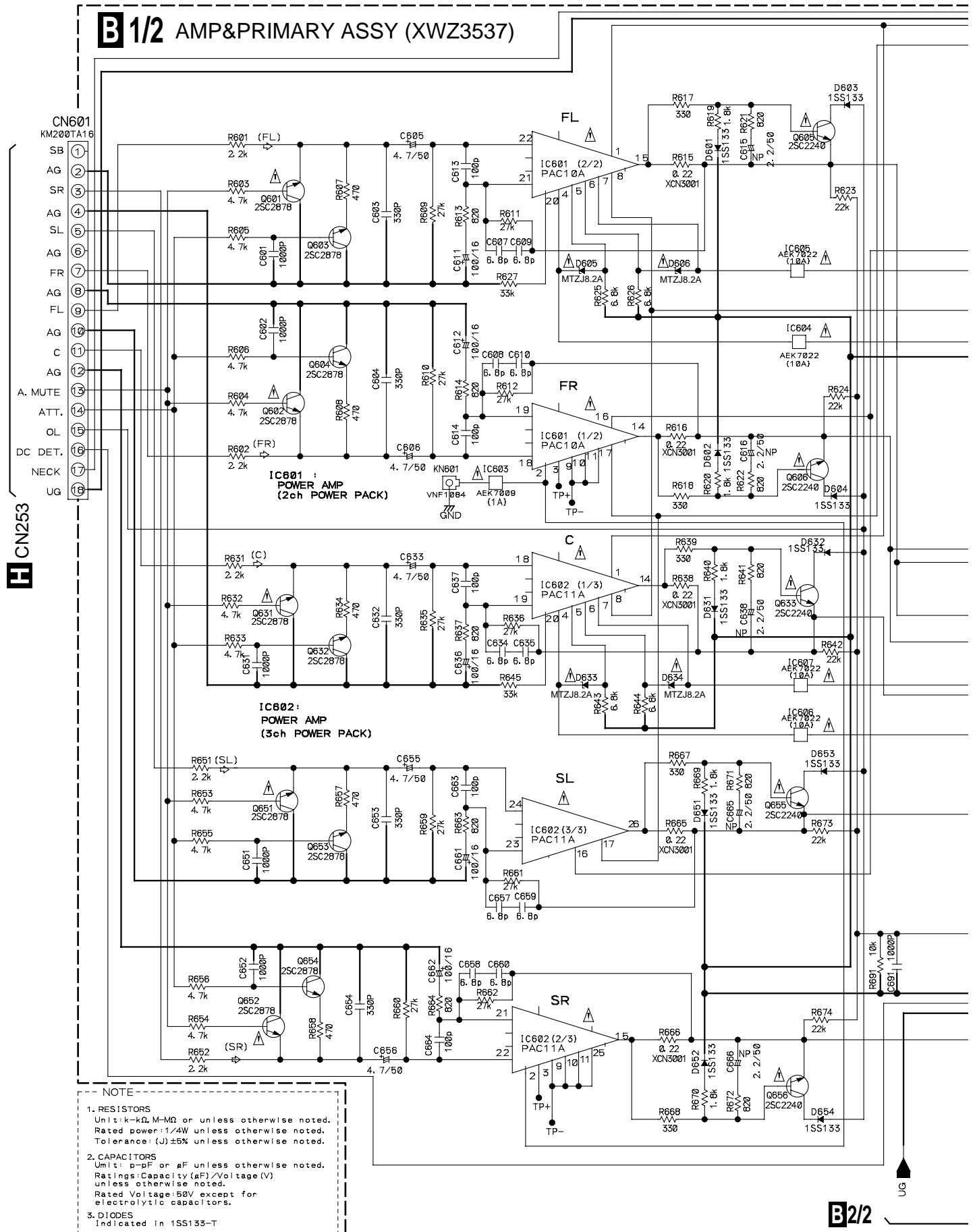

NOTE

1. RESISTORS
Unit: k- Ω M-M Ω or unless otherwise noted.
Rated power: 1/4W unless otherwise noted.
Tolerance: (J) \pm 5% unless otherwise noted.
2. CAPACITORS
Unit: p-pF or μ F unless otherwise noted.
Ratings: Capacity (μ F)/Voltage (V) unless otherwise noted.
Rated Voltage: 50V except for electrolytic capacitors.
3. DIODES
Indicated in 1SS133-T

B 1/2

VSX-D711-K, VSX-D711-S

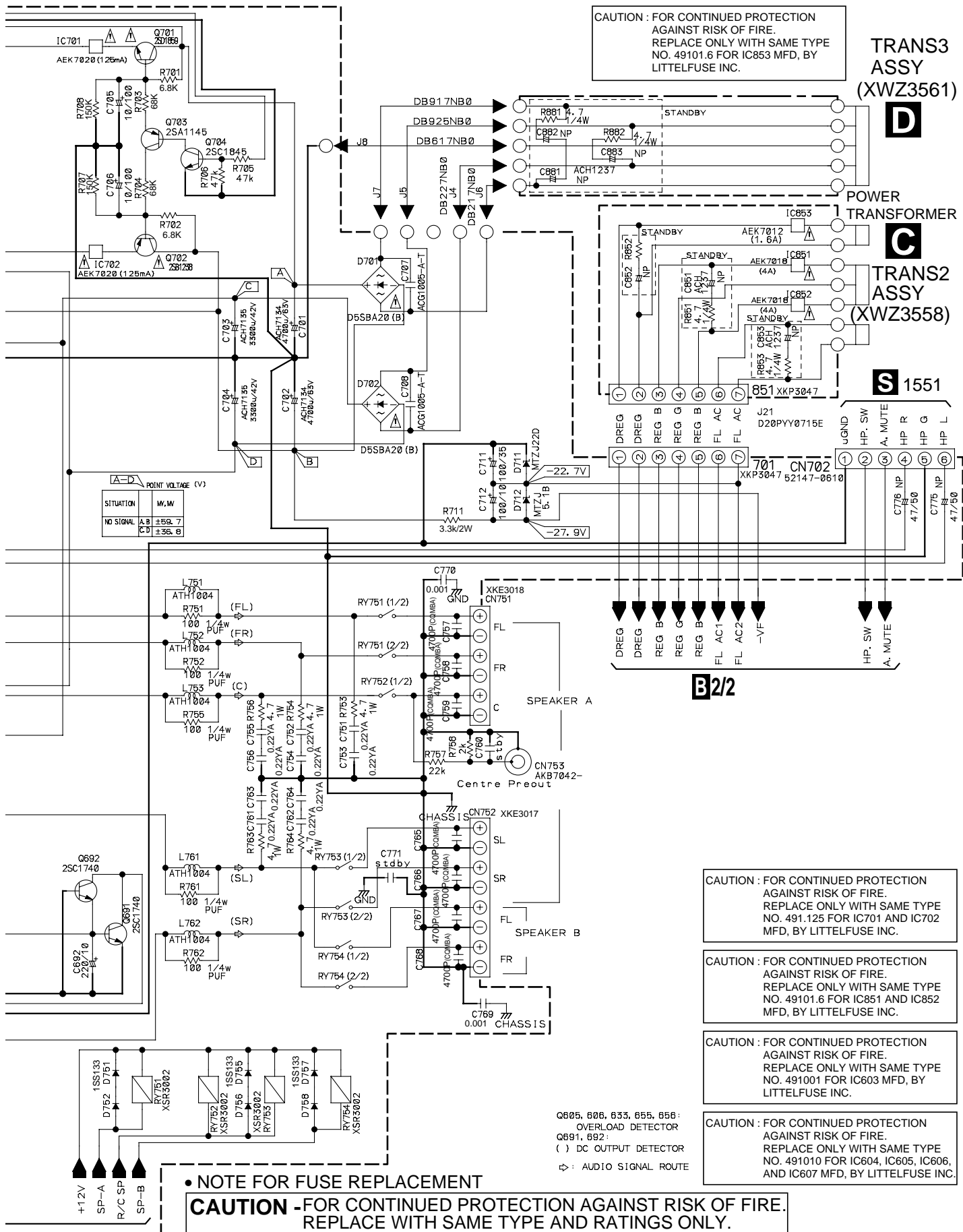

CAUTION : FOR CONTINUED PROTECTION AGAINST RISK OF FIRE. REPLACE ONLY WITH SAME TYPE NO. 49101.6 FOR IC853 MFD, BY LITTELFUSE INC.

TRANS3 ASSY (XWZ3561)

D

POWER TRANSFORMER

C

TRANS2 ASSY (XWZ3558)

S 1551

B2/2

CAUTION : FOR CONTINUED PROTECTION AGAINST RISK OF FIRE. REPLACE ONLY WITH SAME TYPE NO. 491.125 FOR IC701 AND IC702 MFD, BY LITTELFUSE INC.

CAUTION : FOR CONTINUED PROTECTION AGAINST RISK OF FIRE. REPLACE ONLY WITH SAME TYPE NO. 49101.6 FOR IC851 AND IC852 MFD, BY LITTELFUSE INC.

CAUTION : FOR CONTINUED PROTECTION AGAINST RISK OF FIRE. REPLACE ONLY WITH SAME TYPE NO. 491001 FOR IC603 MFD, BY LITTELFUSE INC.

CAUTION : FOR CONTINUED PROTECTION AGAINST RISK OF FIRE. REPLACE ONLY WITH SAME TYPE NO. 491010 FOR IC604, IC605, IC606, AND IC607 MFD, BY LITTELFUSE INC.

Q605, 606, 635, 655, 656 : OVERLOAD DETECTOR
Q691, 692 : () DC OUTPUT DETECTOR
⚡ : AUDIO SIGNAL ROUTE

NOTE FOR FUSE REPLACEMENT

CAUTION -FOR CONTINUED PROTECTION AGAINST RISK OF FIRE. REPLACE WITH SAME TYPE AND RATINGS ONLY.

B1/2 C D

VSX-D711-K, VSX-D711-S

3.8 AMP & PRIMARY(2/2), REGULATOR, HASHIGETA, BOARD TO BOARD, AMP INPUT and TRANS1 ASSYS

HASHIGETA ASSY
(XWZ3567)

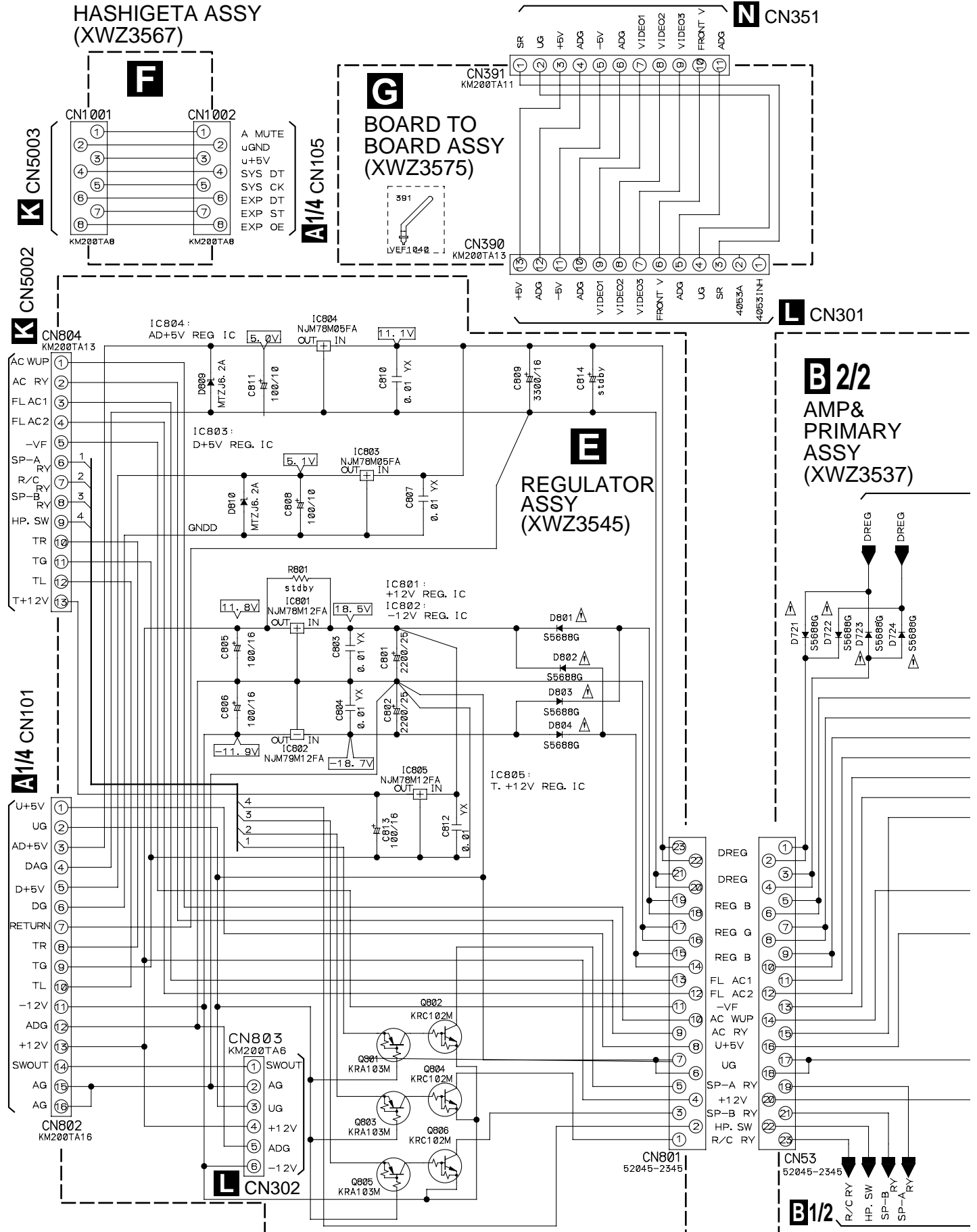

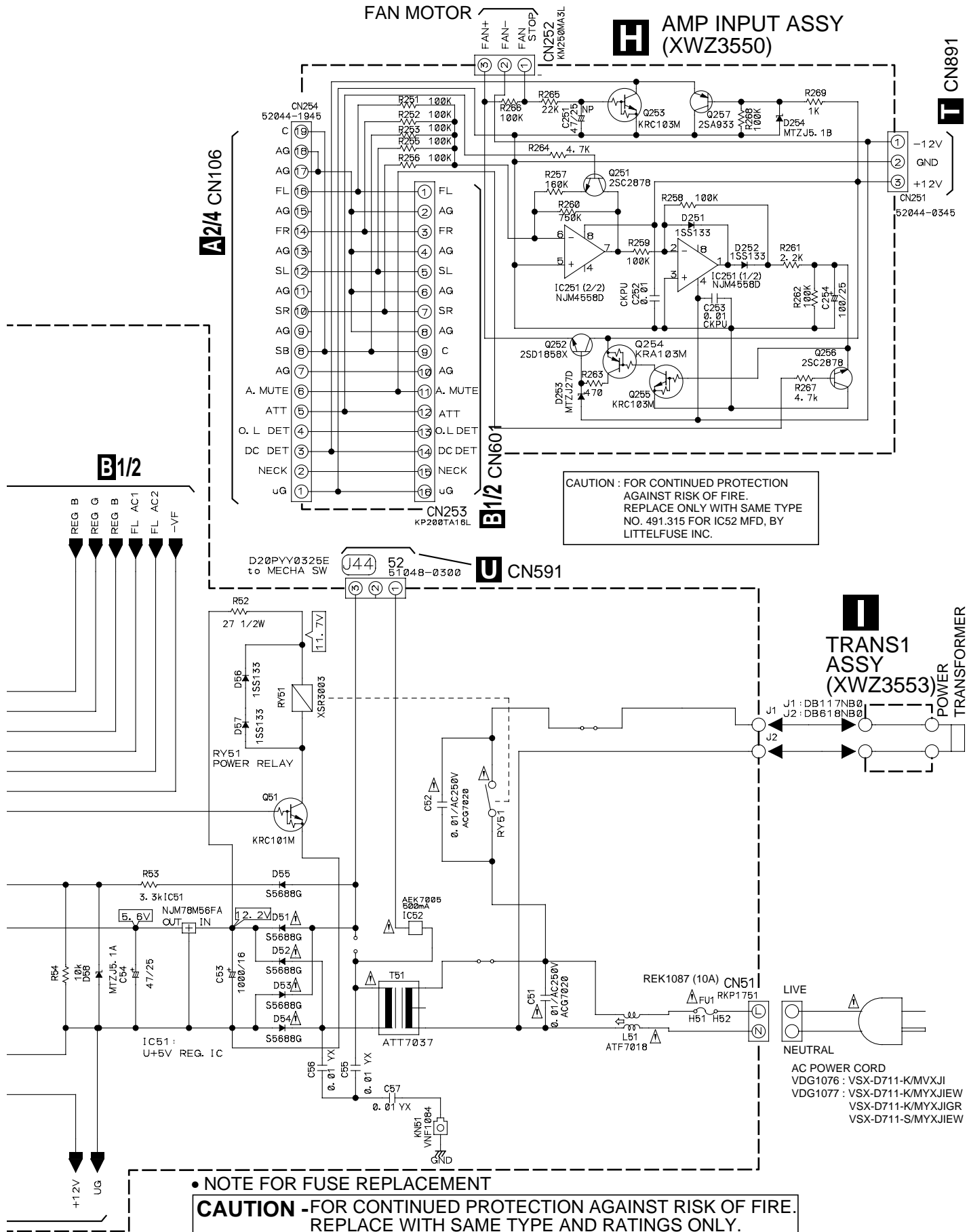

CAUTION : FOR CONTINUED PROTECTION AGAINST RISK OF FIRE. REPLACE ONLY WITH SAME TYPE NO. 491.315 FOR IC52 MFD, BY LITTELFUSE INC.

NOTE FOR FUSE REPLACEMENT
CAUTION -FOR CONTINUED PROTECTION AGAINST RISK OF FIRE. REPLACE WITH SAME TYPE AND RATINGS ONLY.

3.10 KAWA ASSY

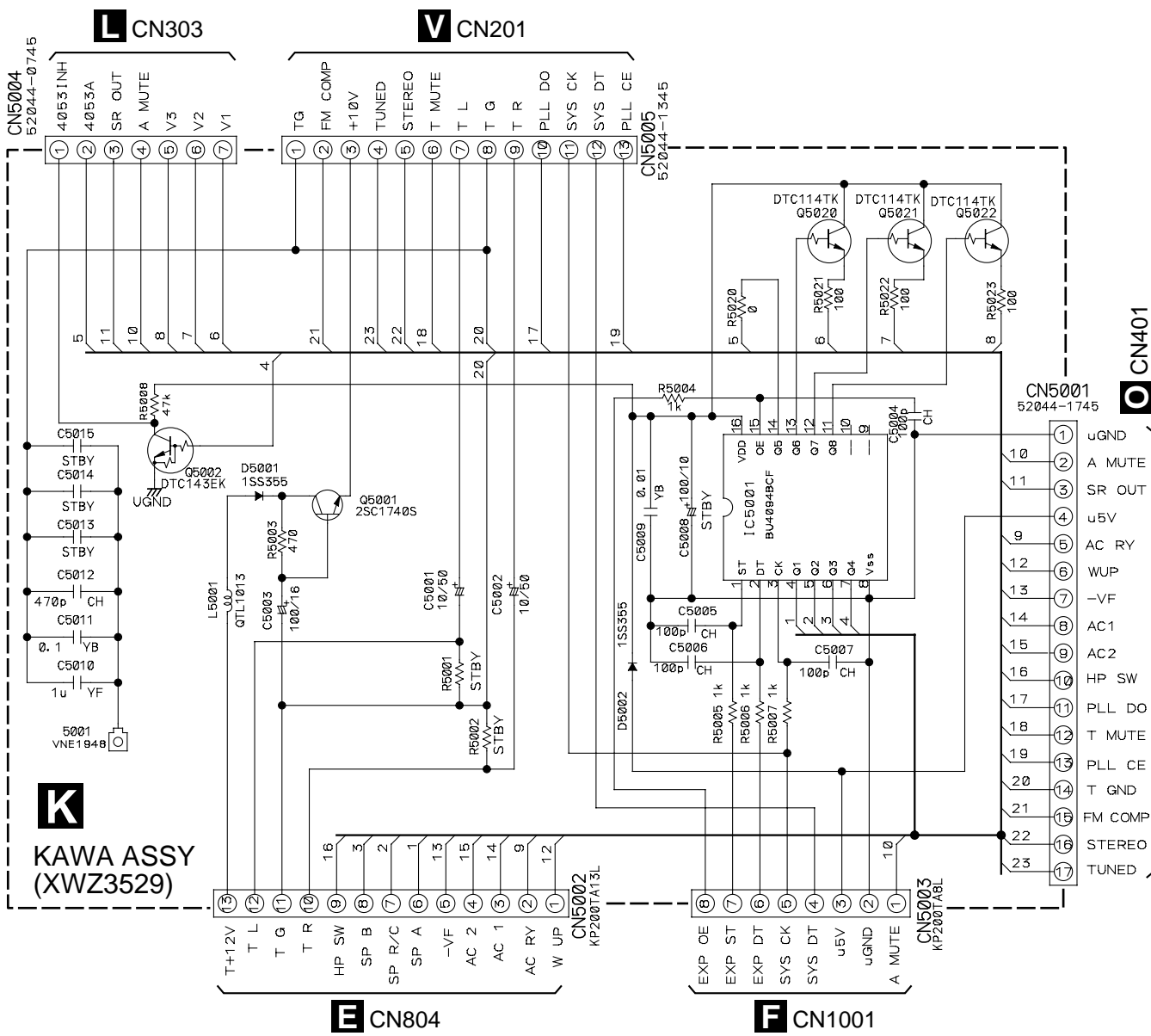

VSX-D711-K, VSX-D711-S

3.11 VIDEO and 6CH IN ASSYS

L VIDEO ASSY (XWZ3584)

A

B

C

D

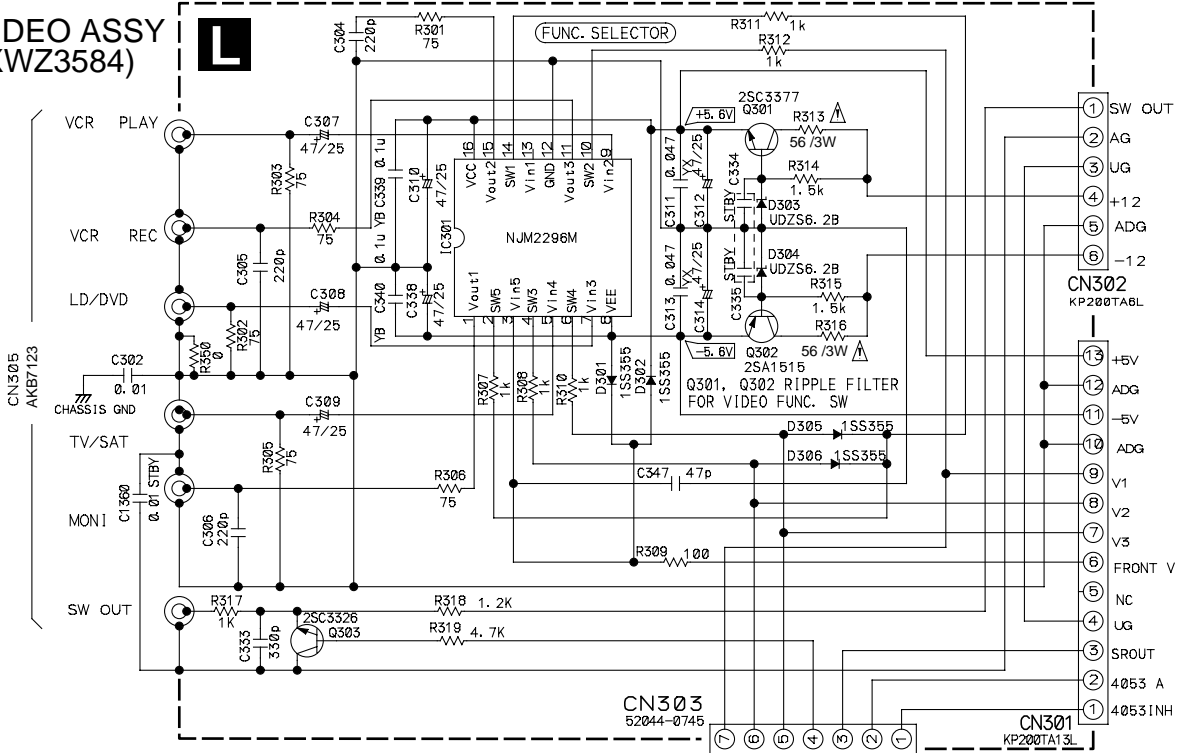

E CN803

G CN390

A1/4 CN104

K CN5004

M 6CH IN ASSY (XWZ3507)

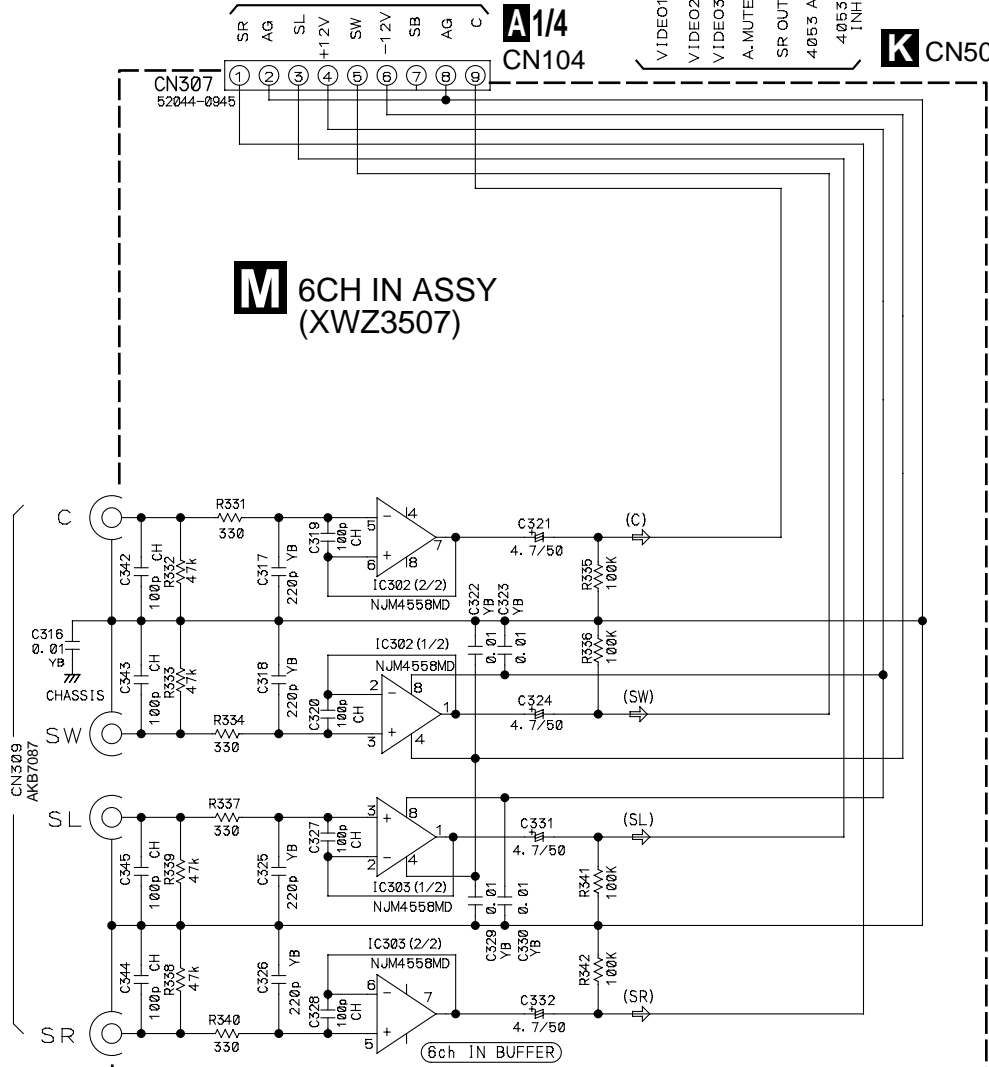

3.11 S. VIDEO ASSY

- NOTE
- RESISTORS
Unit: k-k Ω , M-M Ω or Ω unless otherwise noted.
Rated power: 1/10W unless otherwise noted.
Tolerance: (J) \pm 5% unless otherwise noted.
 - CAPACITORS
Unit: p-pF or μ F unless otherwise noted.
Ratings: Capacity (μ F)/Voltage (V) unless otherwise noted.
Rated Voltage: 50V except for electrolytic capacitors.
 - DIODES
Indicated in 1S5355-TRB

NJM2296D control port status

SW1	SW2	SW3	SW4	SW5	Vout1	Vout2	Vout3
1	0	(1)	0	1	Vin2	Vin2	mute
1	1	(1)	0	1	Vin3	Vin3	Vin3
1	1	0	1	1	Vin4	Vin4	Vin4
1	1	1	1	1	Vin5	Vin5	Vin5
0	0	(0)	(0)	0	mute	mute	mute

VIN 2. VCR
VIN 3. DVD/LD
VIN 4. TV/SAT
VIN 5. FRONT
Vout1. MON out
Vout2. MR out
Vout3. VCR out

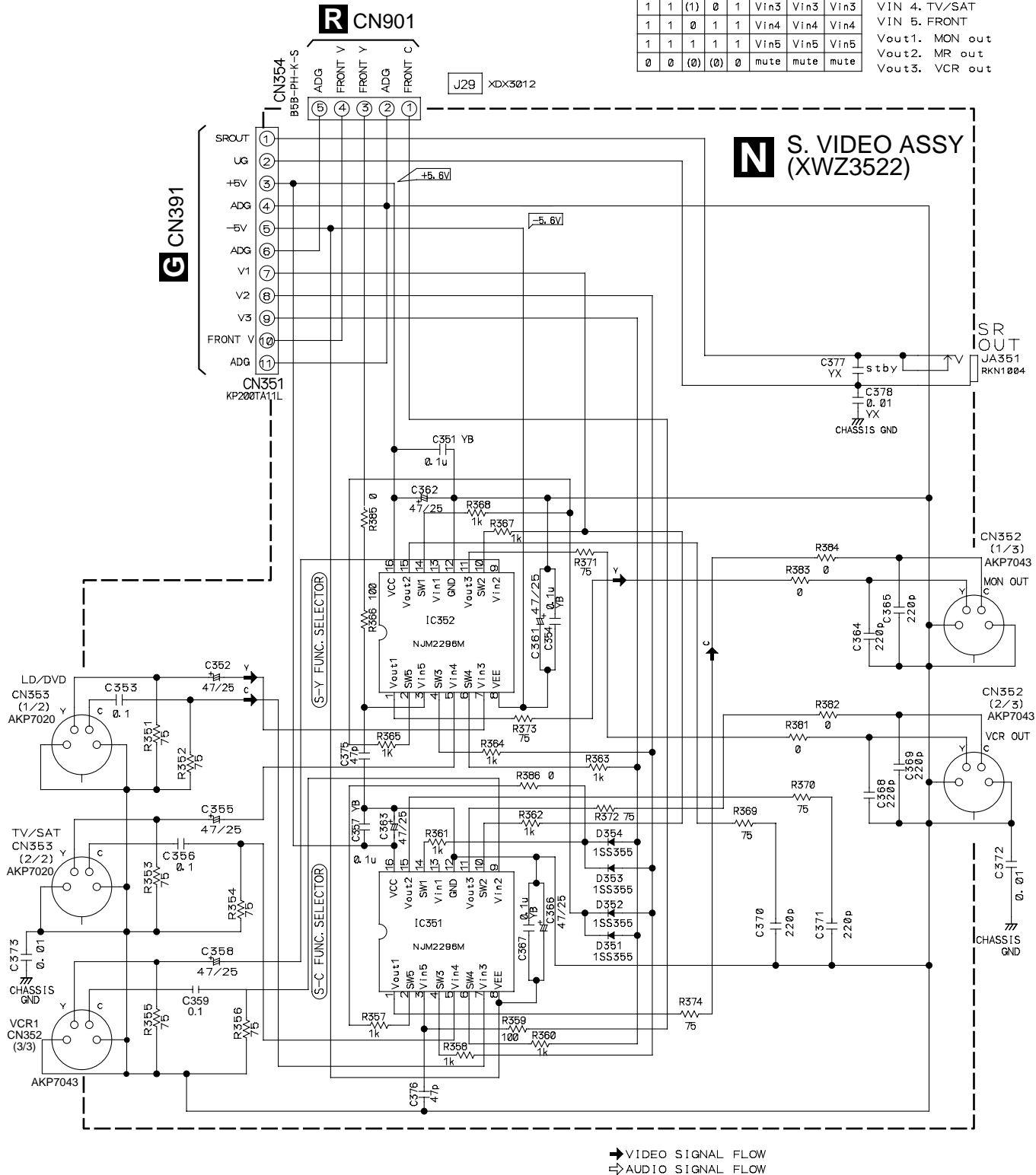

→ VIDEO SIGNAL FLOW
⇨ AUDIO SIGNAL FLOW

VSX-D711-K, VSX-D711-S

3.13 FRONT, R. ENCODER and POWER SW ASSYS

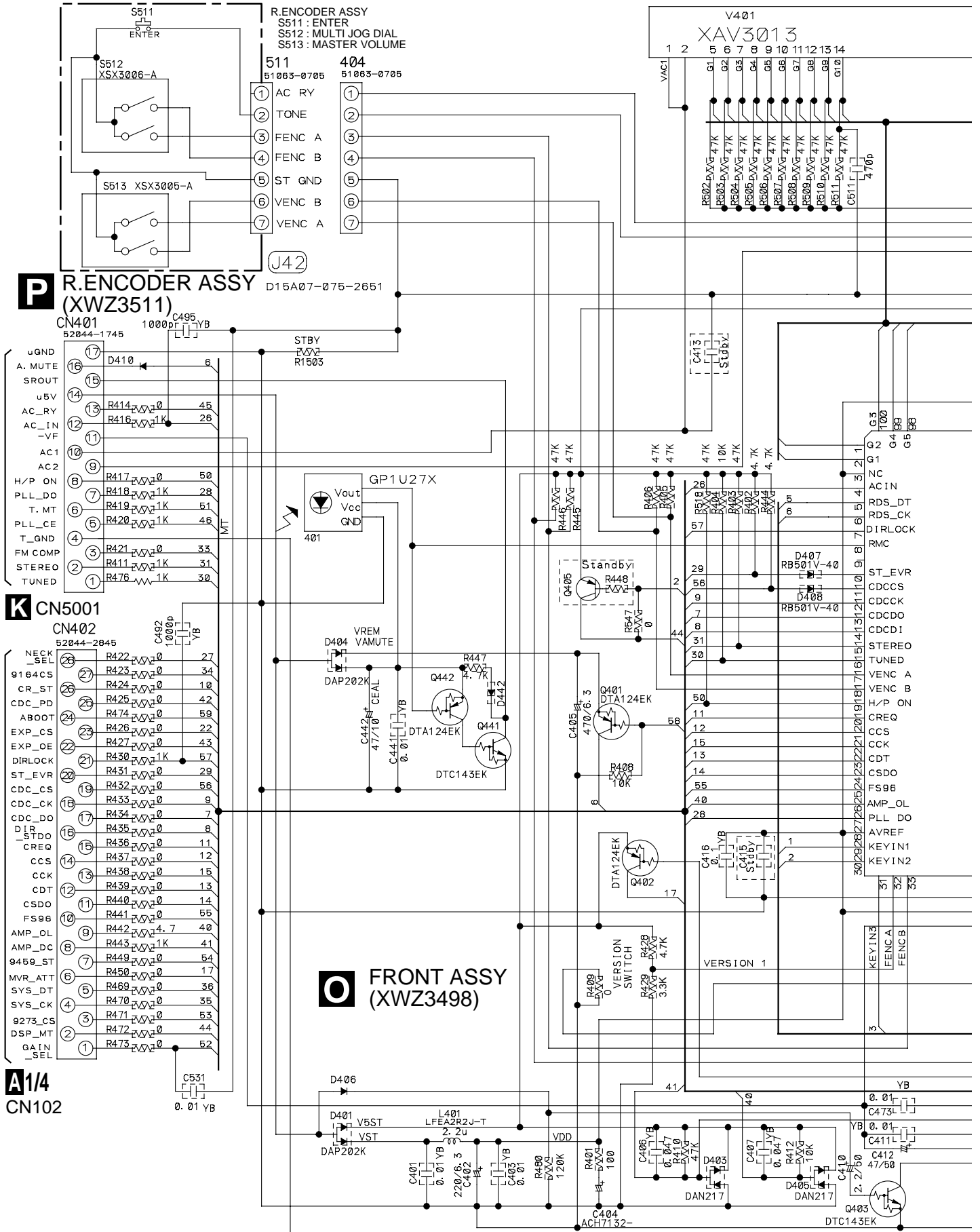

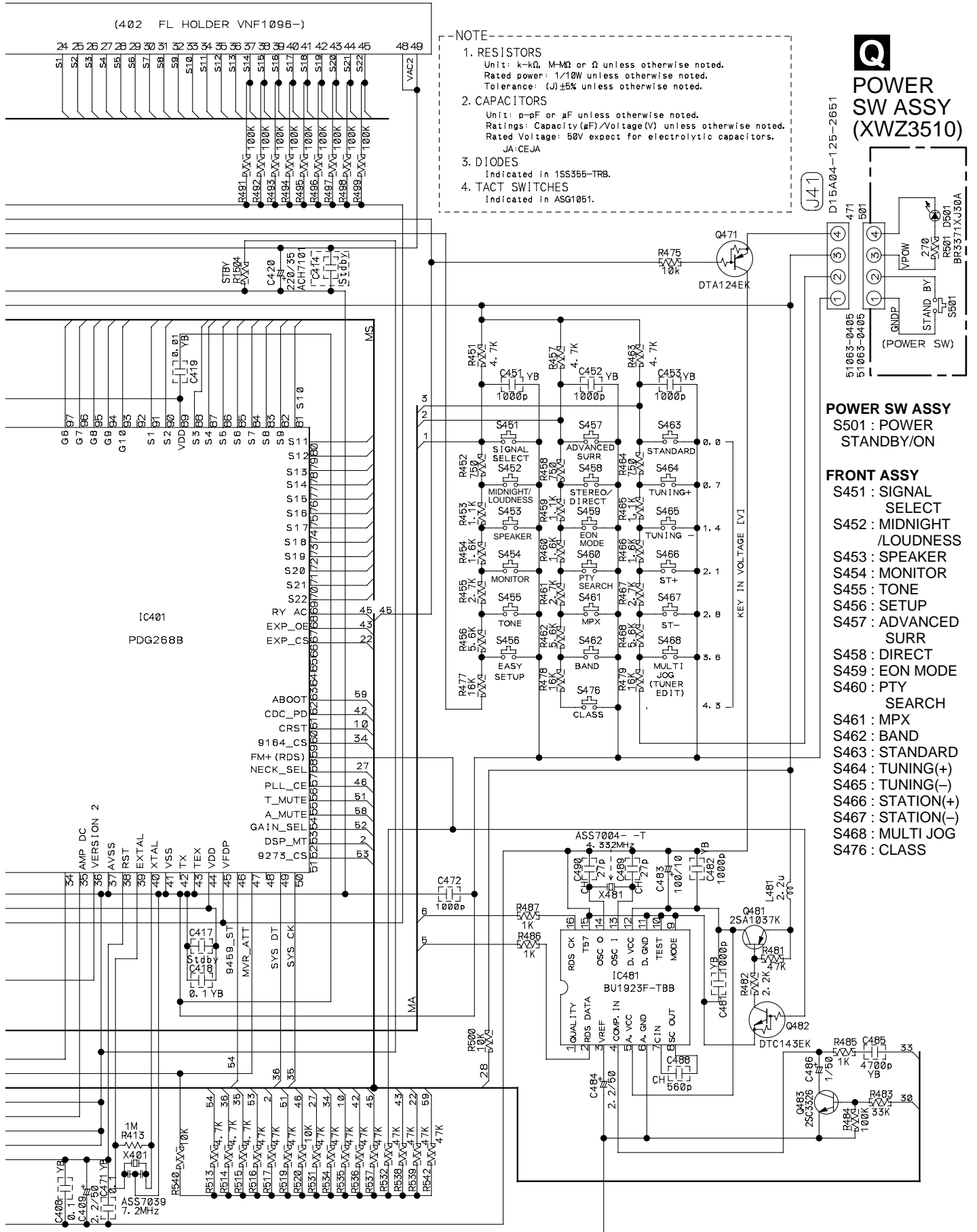

A

B

C

D



3.14 FRONT VIDEO and H.P. ASSYS

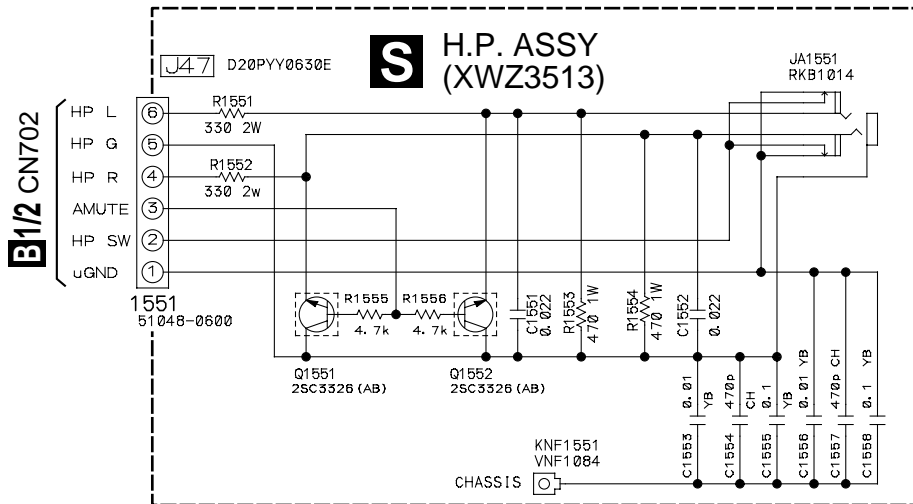
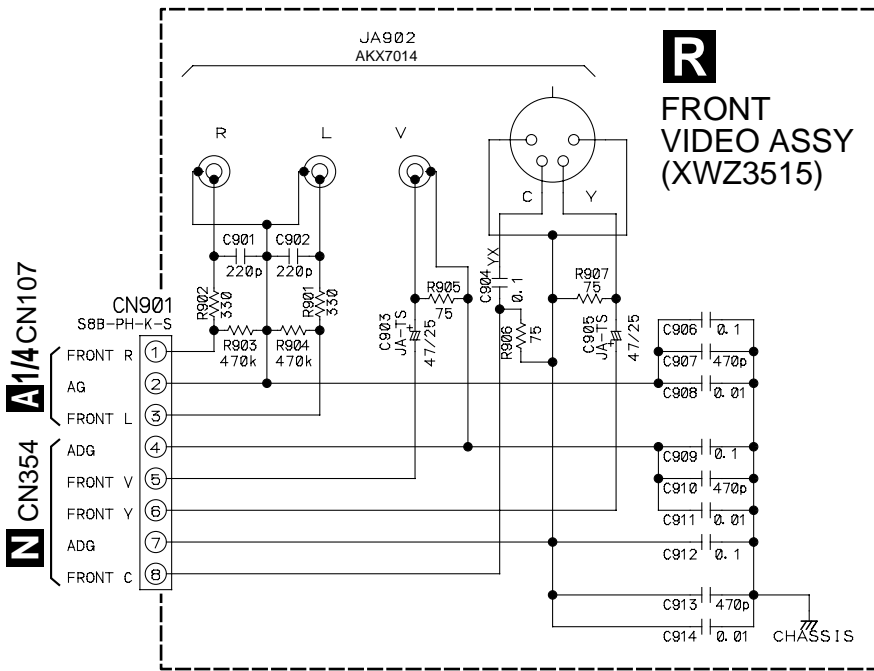

3.15 TRANS4 and MECHA SW ASSYS

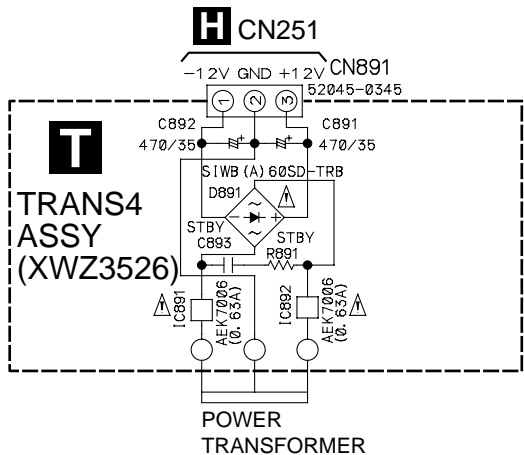

CAUTION : FOR CONTINUED PROTECTION
AGAINST RISK OF FIRE.
REPLACE ONLY WITH SAME TYPE
NO. 491.630 FOR IC891 AND IC892
MFD, BY LITTELFUSE INC.

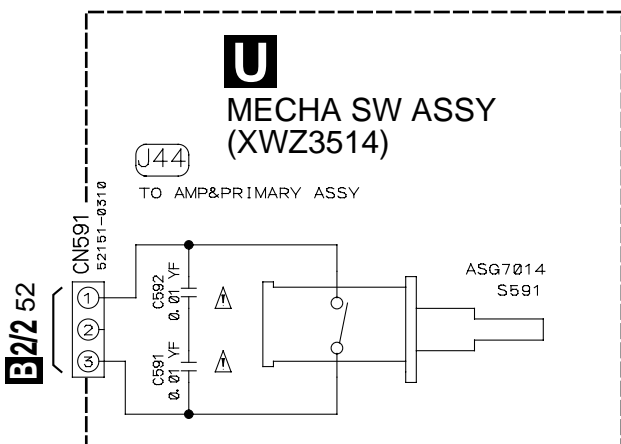

3.16 FM/AM TUNER MODULE

FM/AM TUNER MODULE (AXQ7232)

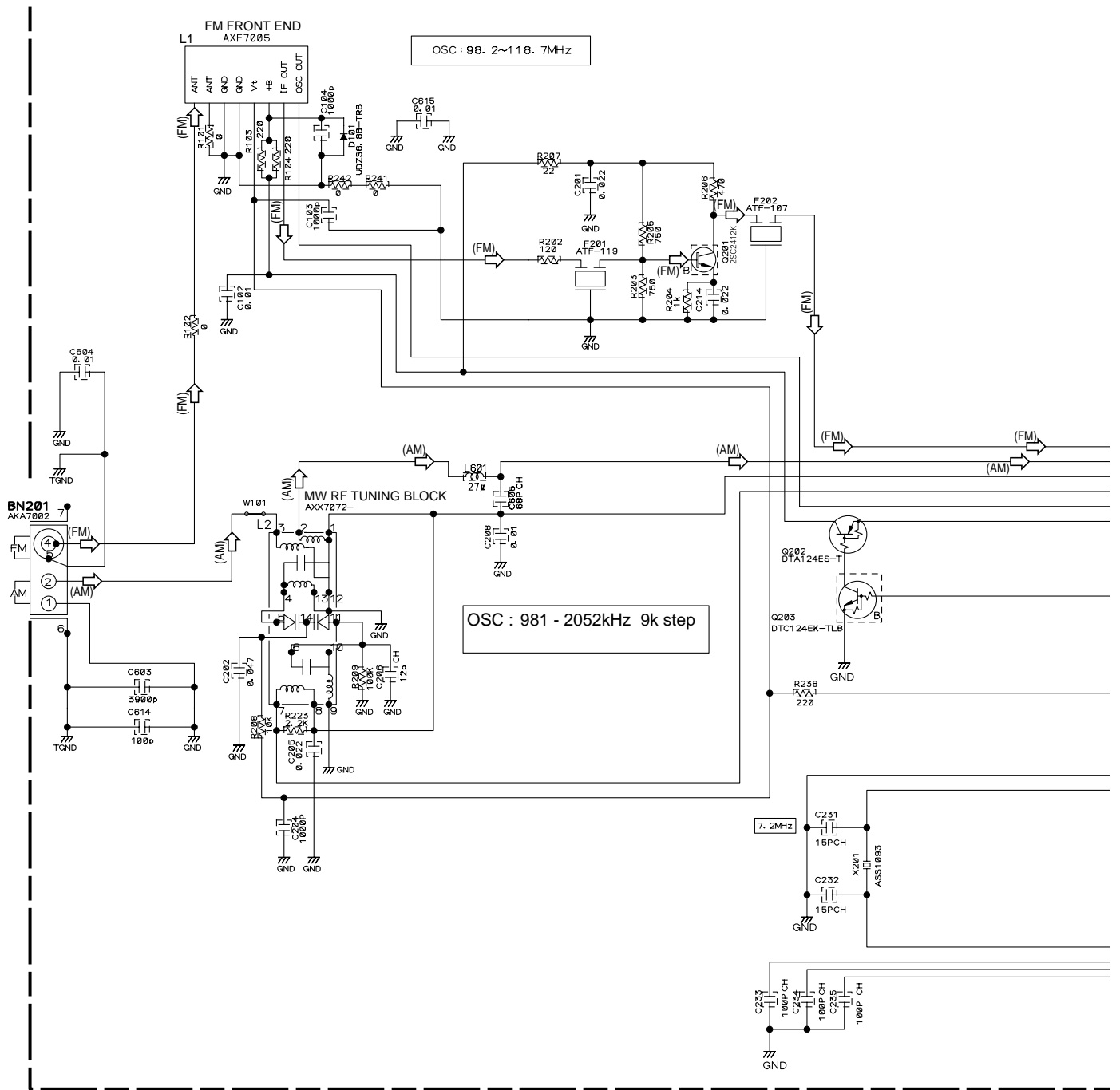

Notes

1. RESISTORS

Indicated in Ω, 1/16W±5% Tolerance unless otherwise noted K:KΩ, M:MΩ.

2. CAPACITORS

Indicated in Capacity (μF)/VOLTAGE (V) unless otherwise noted P:PF.

3. DIODES

No mark diode is 1SS133.

○ : The power supply is shown with the marked box.

- (TX) : AUDIO SIGNAL ROUTE (TUNER)
- (AM) : AM SIGNAL ROUTE
- (FM) : FM SIGNAL ROUTE

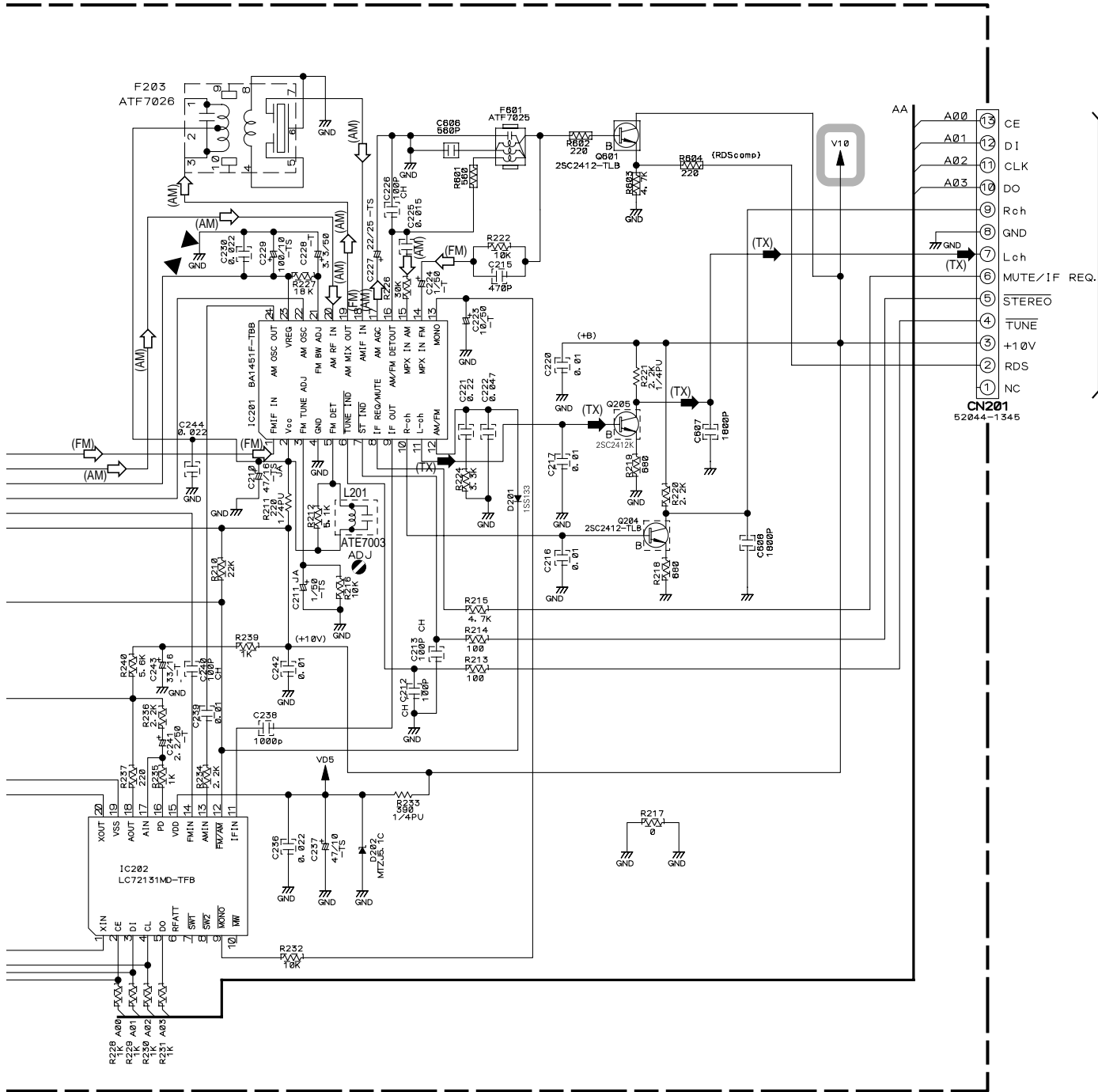

K CN5005

A

B







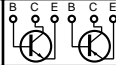

C

D

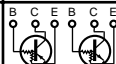
4. PCB CONNECTION DIAGRAM

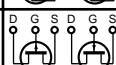
NOTE FOR PCB DIAGRAMS :

1. Part numbers in PCB diagrams match those in the schematic diagrams.
2. A comparison between the main parts of PCB and schematic diagrams is shown below.

Symbol In PCB Diagrams	Symbol In Schematic Diagrams	Part Name
		Transistor
		Transistor with resistor
		Field effect transistor
		Resistor array
		3-terminal regulator

3. The parts mounted on this PCB include all necessary parts for several destinations.
For further information for respective destinations, be sure to check with the schematic diagram.
4. View point of PCB diagrams.

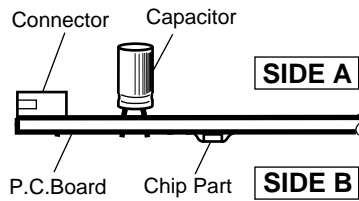

4.1 TRANS 1, TRANS 2, TRANS 3 and TRANS 4 ASSYS

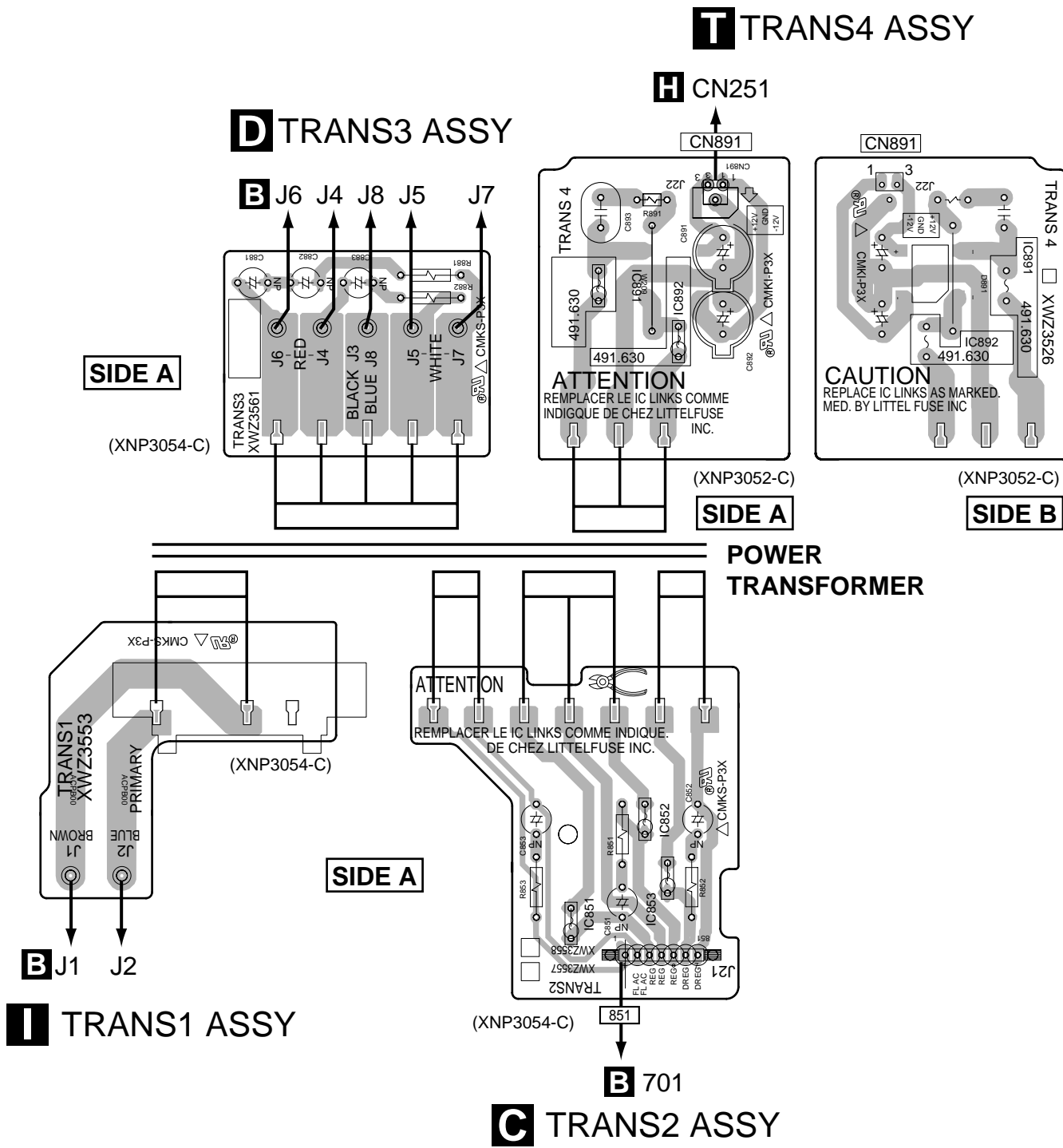

4.2 DD & INPUT ASSY

A D.D & INPUT ASSY

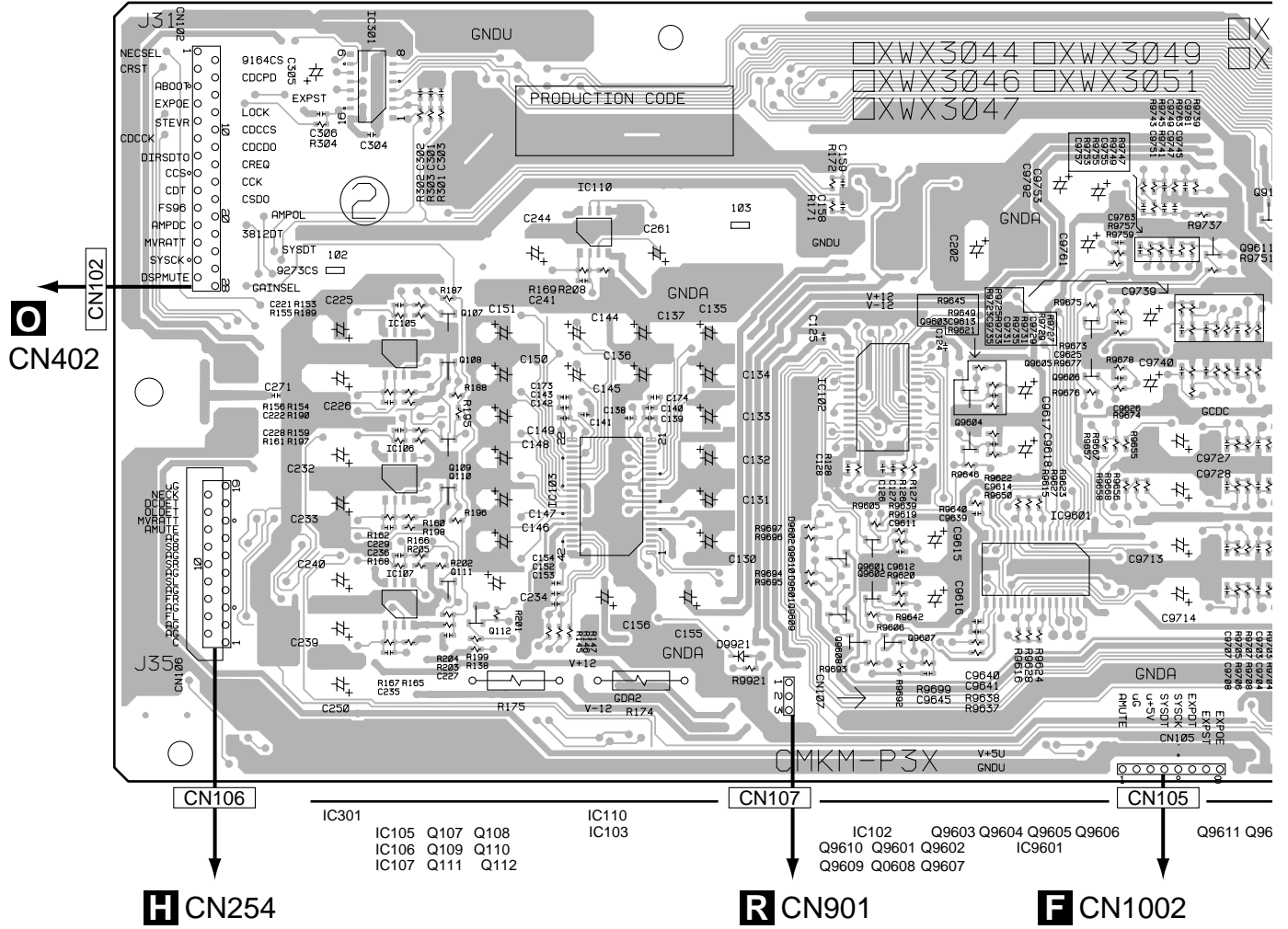

SIDE A

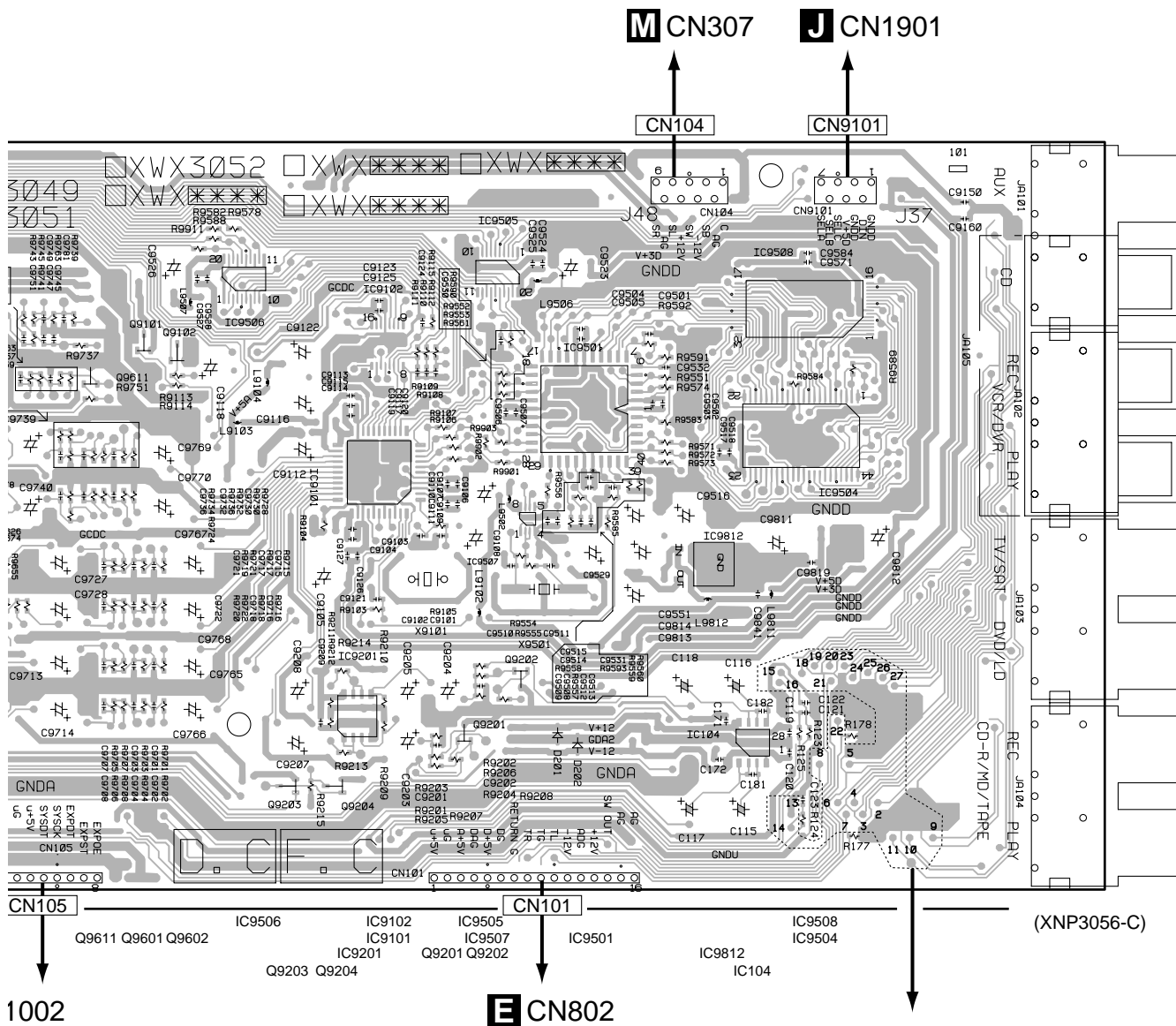

Note : The pin of function IC (IC101 TC9273F-007) can be checked from side-A by the through-hole round. The pin No. is printed on the side-A.

Even if the FM/AM TUNER MODULE is disconnected, other functions can operate.

A D.D & INPUT ASSY

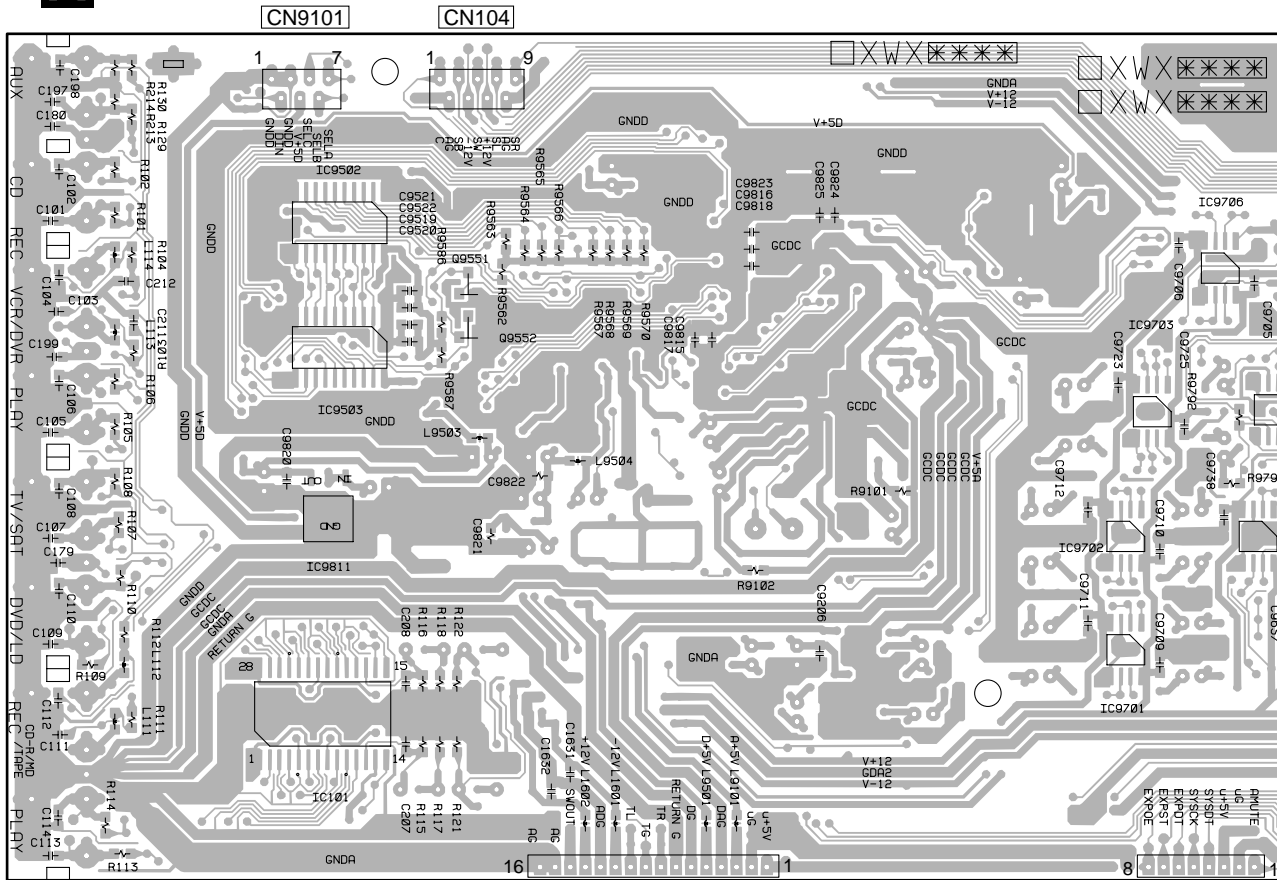

IC9502
 IC9503
 IC9811
 IC101
 Q9551 Q9552

IC9705
 IC9703
 IC9702
 IC9701

SIDE B

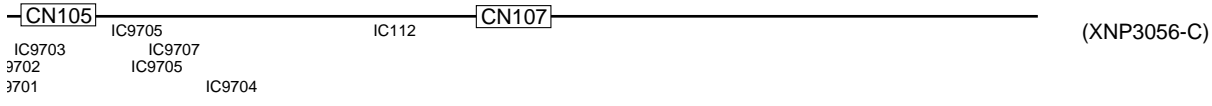
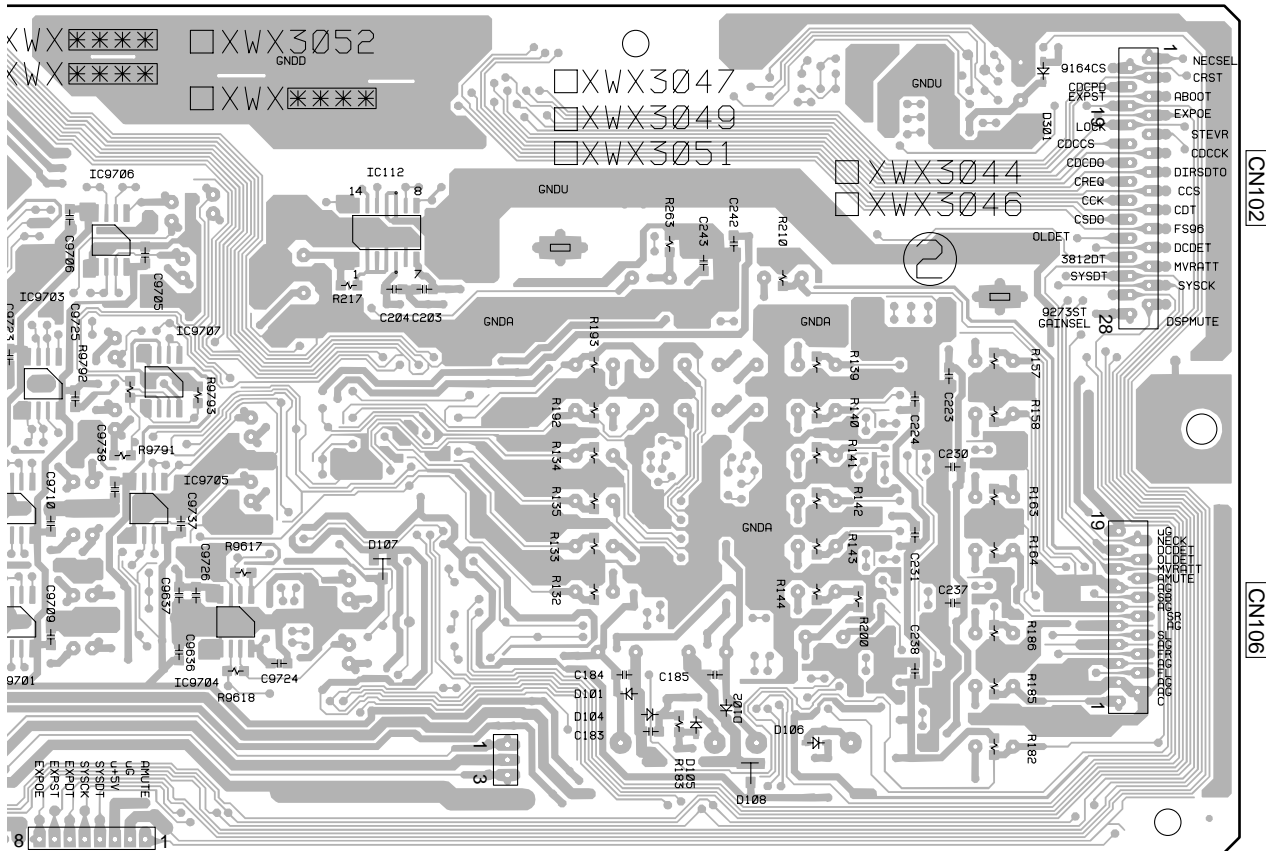

A

B

C

D

4.3 AMP & PRIMARY, AMP INPUT and MECHA SW ASSYS

SIDE A

U MECHA SW ASSY

SIDE A

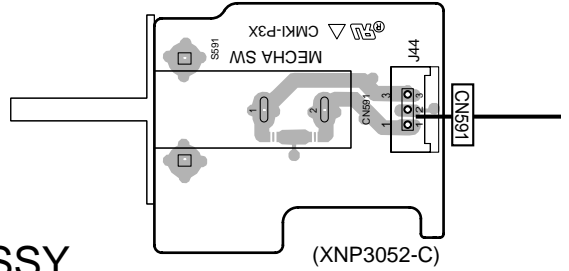
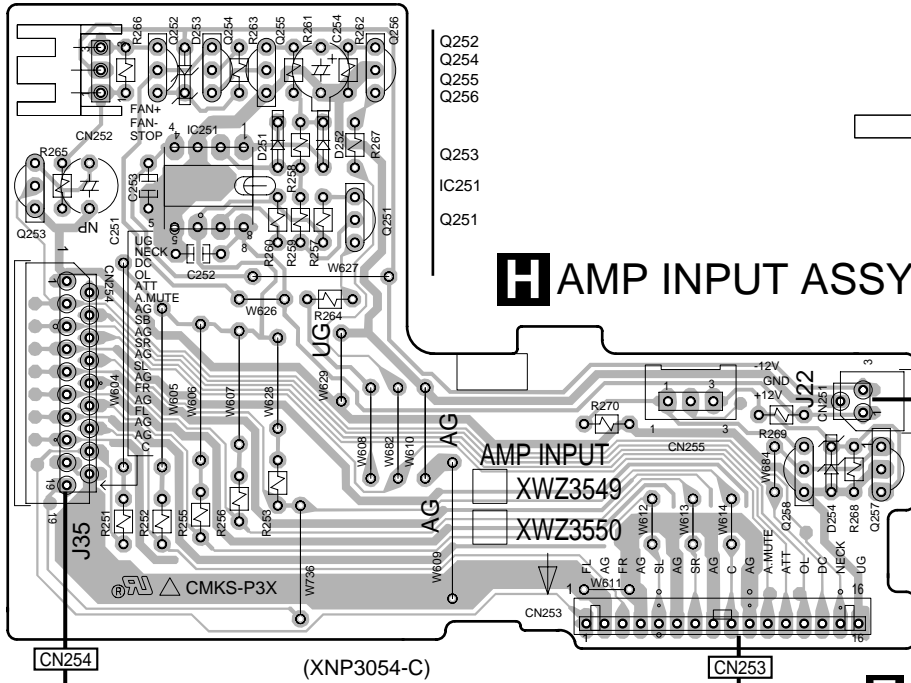

SIDE B

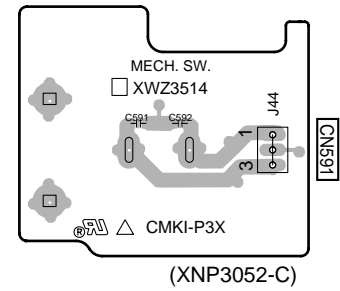

T CN891

A CN106

B AMP&PRIMARY ASSY

D J8

Q704
Q702
IC702
Q703

IC701
Q701

Q655

Q691 Q631
Q692 Q632
Q656 Q604
Q653 Q606
Q652 Q605
Q654 IC607
IC606 Q602

Q651 Q603
Q653 Q604
IC605
IC604

Q601
IC602
IC601
IC603

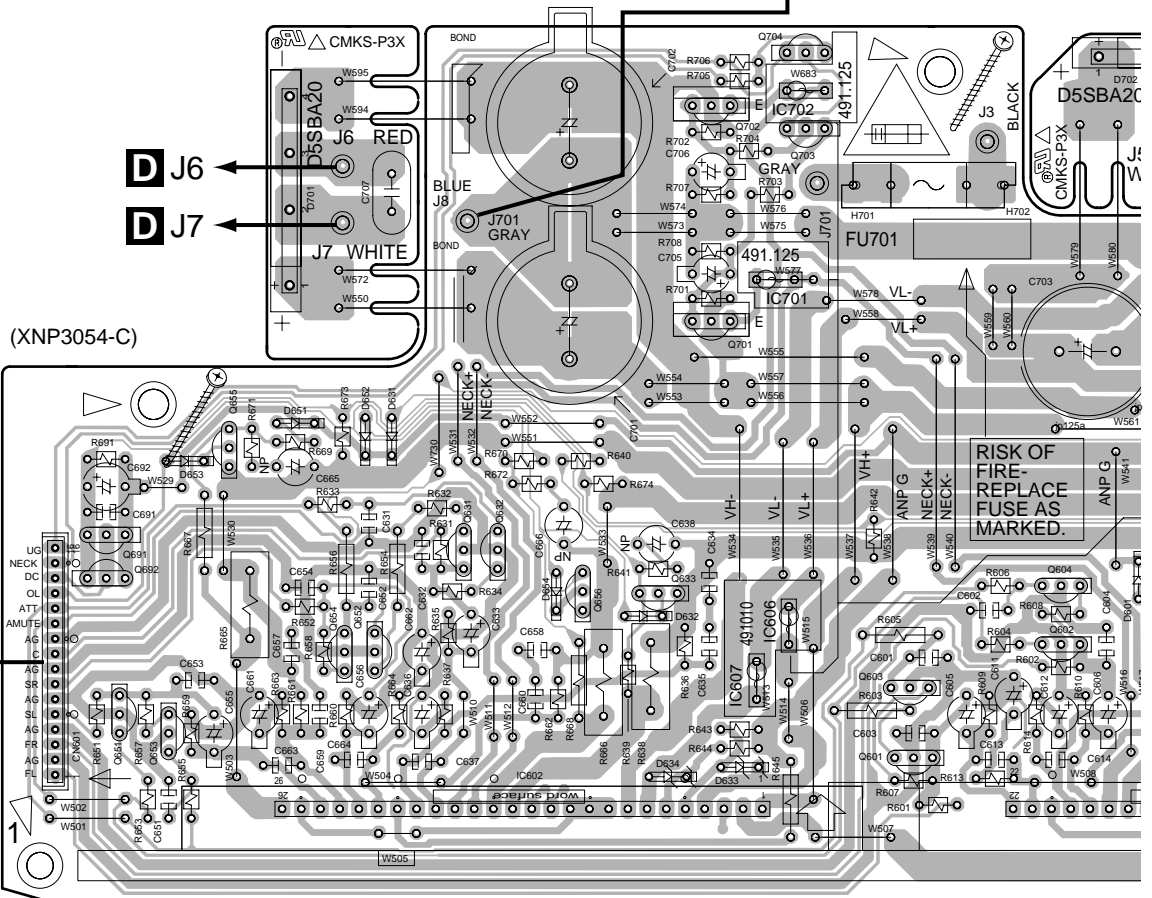

SY

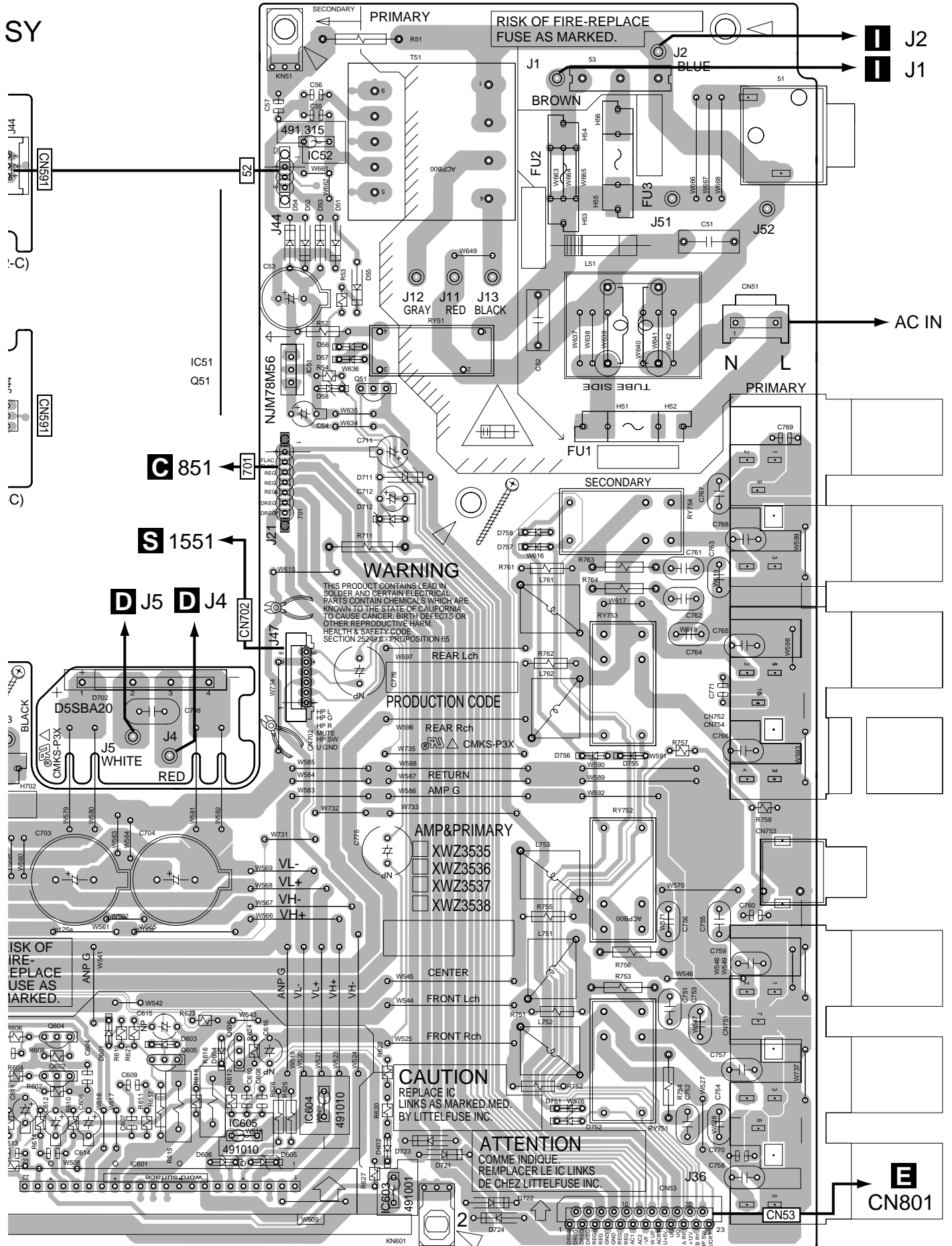

C 851

S 1551

D J5 D J4

J2
J1

AC IN

WARNING

THIS PRODUCT CONTAINS LEAD IN SOLDER AND CERTAIN ELECTRICAL PARTS CONTAIN CHEMICALS WHICH ARE KNOWN TO THE STATE OF CALIFORNIA TO CAUSE CANCER, BIRTH DEFECTS OR OTHER REPRODUCTIVE HARM. HEALTH & SAFETY CODE SECTION 25249.6 - PROPOSITION 65

PRODUCTION CODE

REAR Lch
REAR Rch
RETURN
AMP G

AMP&PRIMARY

XWZ3535
XWZ3536
XWZ3537
XWZ3538

CENTER

FRONT Lch

FRONT Rch

CAUTION

REPLACE IC LINKS AS MARKED. MED. BY LITTELFUSE INC.

ATTENTION

COMME INDIQUE. REMPLACER LE IC LINKS DE CHEZ LITTELFUSE INC.

CN801

B

4.4 REGULATOR, HASHIGETA and KAWA ASSYS

F HASHIGETA ASSY

A

SIDE A

A CN105

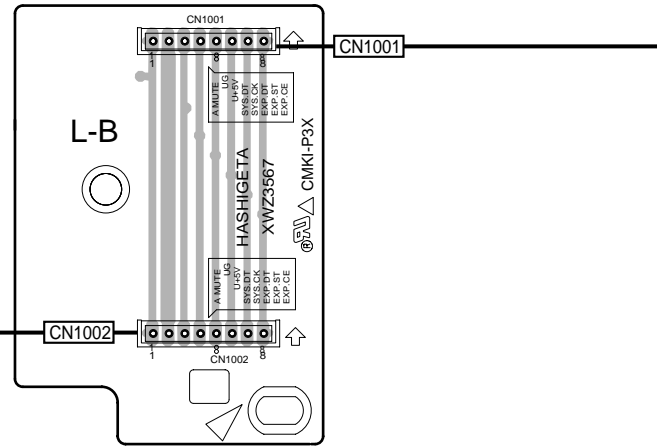

(XNP3054-C)

B

E REGULATOR ASSY

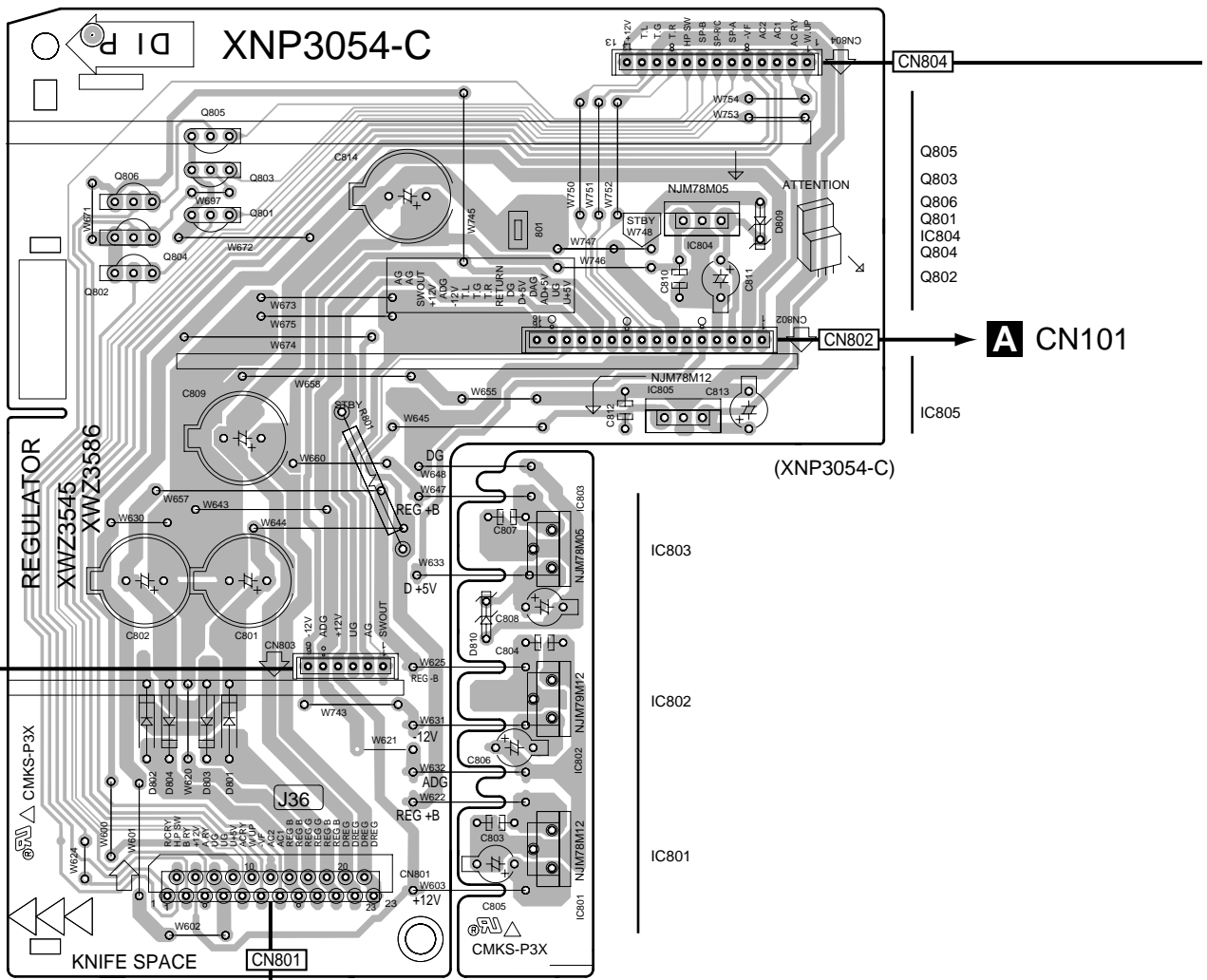

(XNP3054-C)

A CN101

L CN302

B CN53

SIDE A

SIDE B

KAWA ASSY

KAWA ASSY

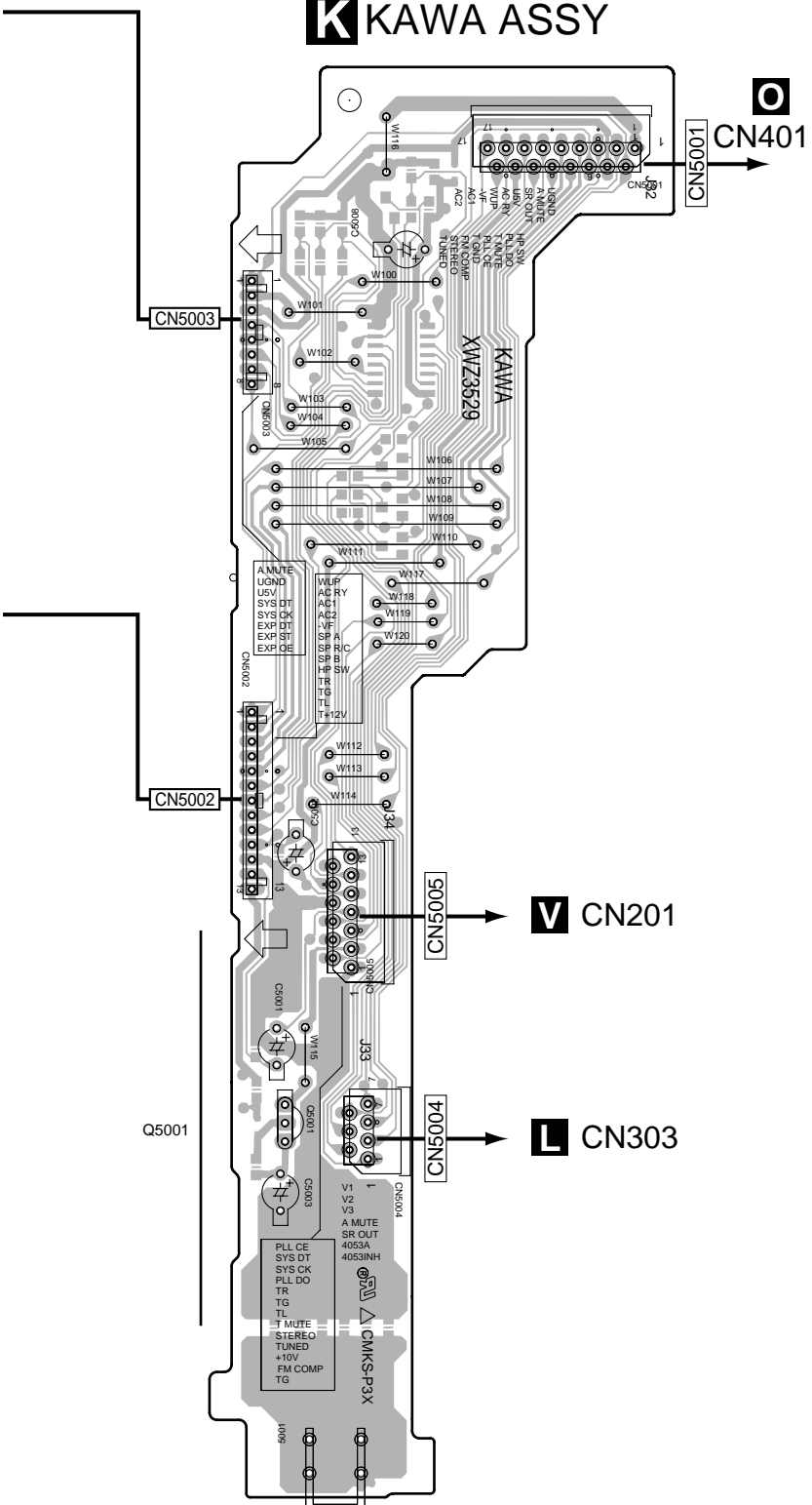

(XNP3052-C)

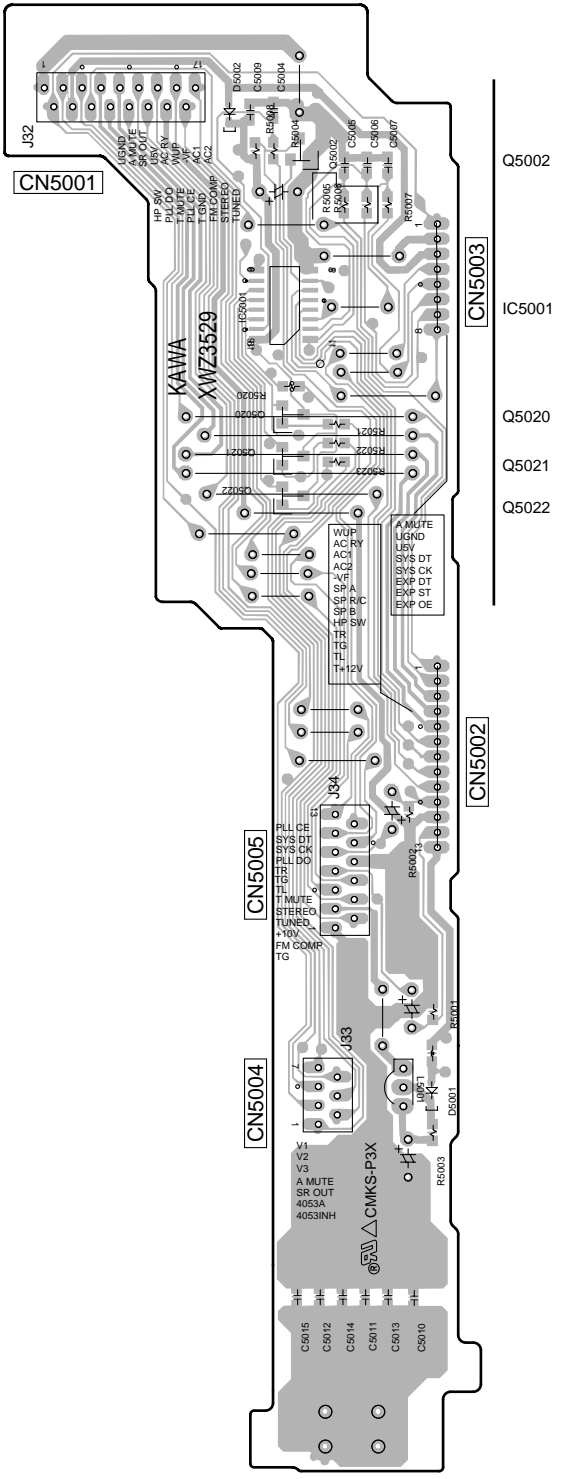

(XNP3052-C)

1

2

3

4

1

2

3

4



4.5 BOARD TO BOARD, DIGITAL IN, VIDEO and 6CH IN ASSYS

J DIGITAL IN ASSY

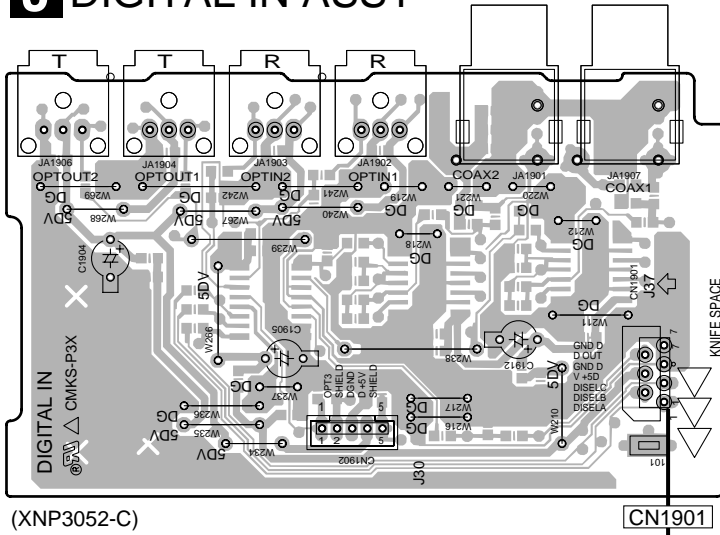

M 6CH IN ASSY

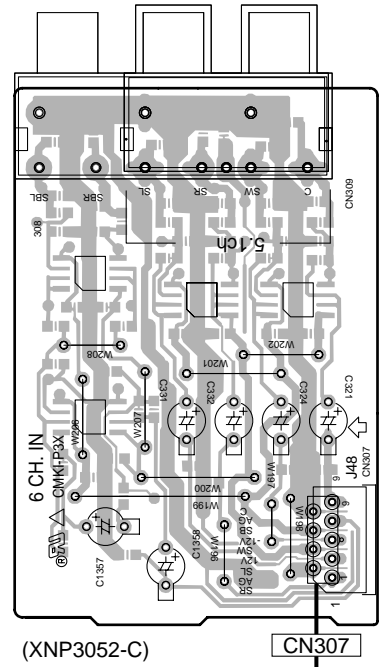

A CN9101

L VIDEO ASSY

A CN104

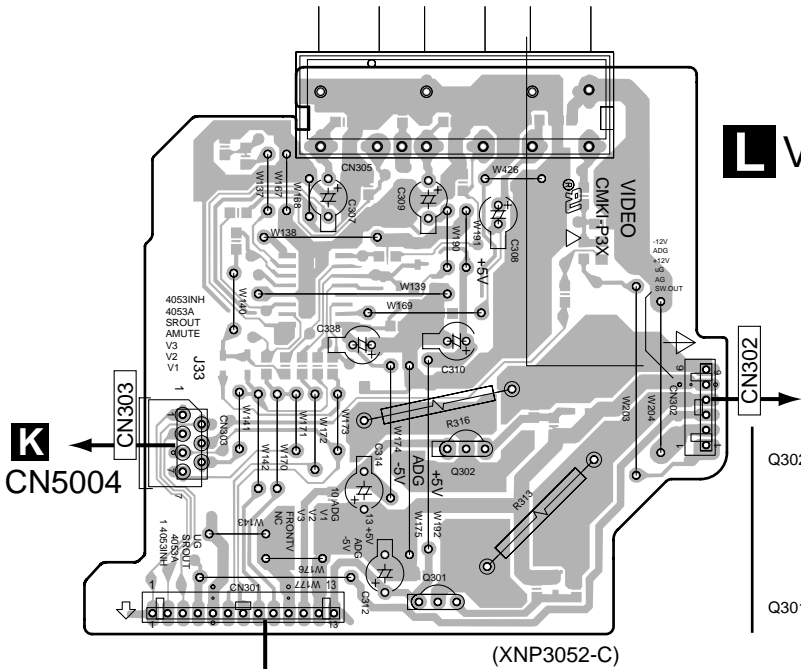

E CN803

SIDE A

K CN5004

G BOARD TO BOARD ASSY

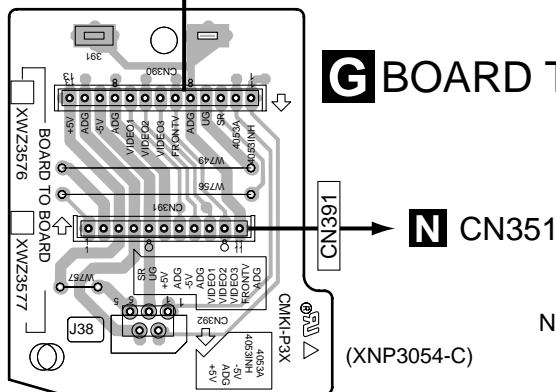

N CN351

Note : The PCB of the BOARD TO BOARD ASSY is one-side patterned board.

M 6CH IN ASSY

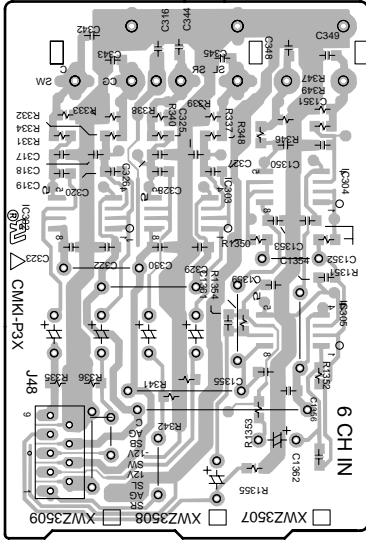

CN307 (XNP3052-C)

J DIGITAL IN ASSY

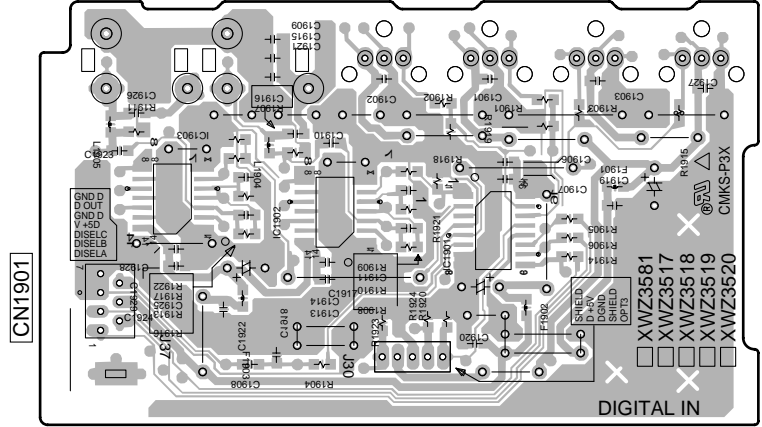

CN1902 (XNP3052-C)
IC1903 IC1902 IC1901

L VIDEO ASSY

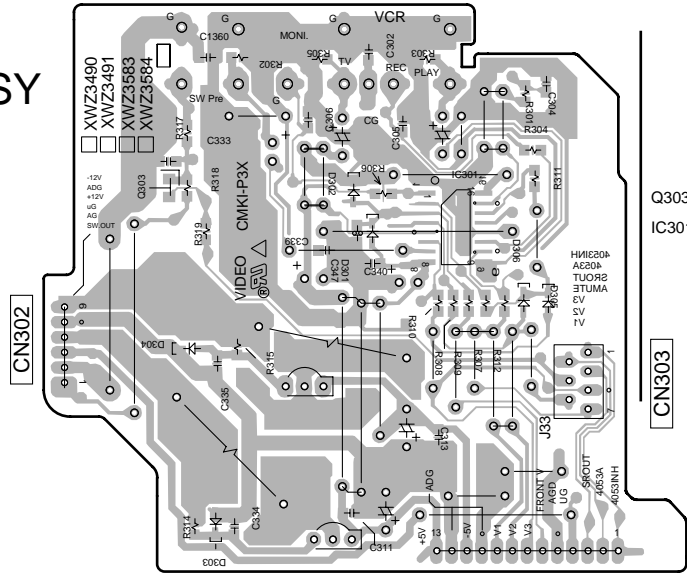

(XNP3052-C) CN301

SIDE B

4.6 S. VIDEO and FRONT VIDEO ASSYS

SIDE A

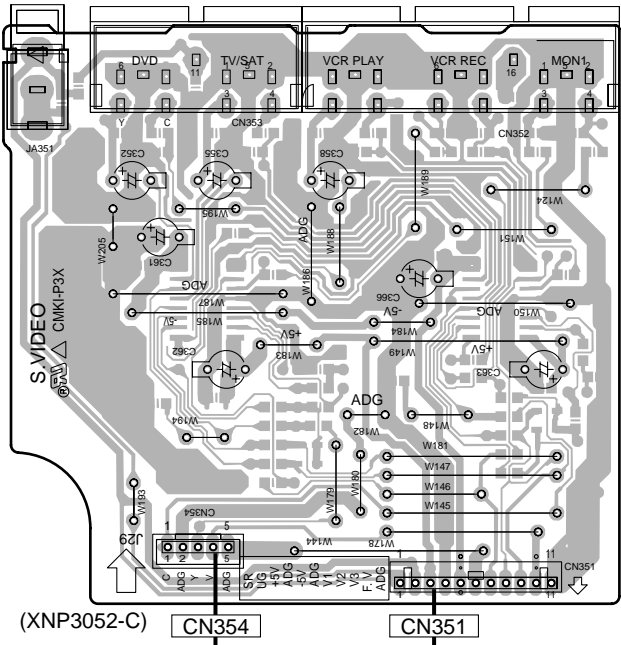

N S. VIDEO ASSY

G CN391

A CN107

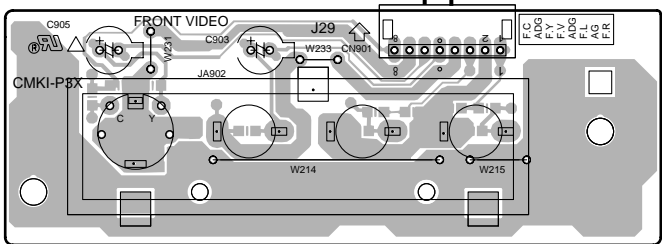

R FRONT VIDEO ASSY

(XNP3052-C)

SIDE B

N S. VIDEO ASSY

IC351
IC352

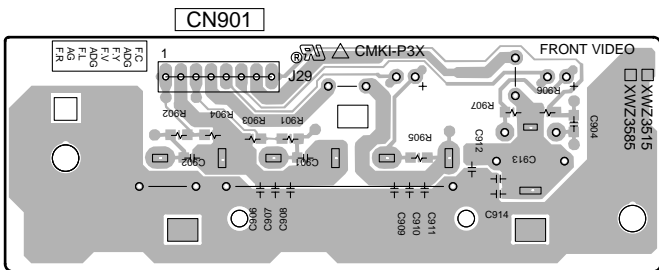
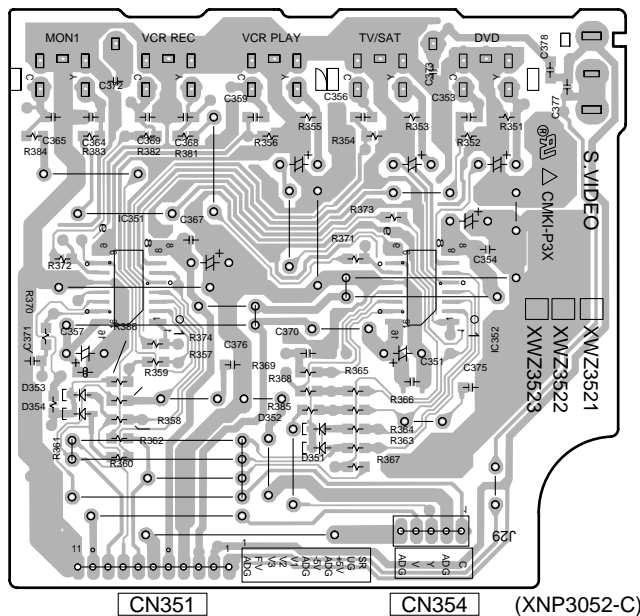

(XNP3052-C)

R FRONT VIDEO ASSY

4.7 FRONT, POWER SW, H.P. and R. ENCODER ASSYS

Q FRONT ASSY

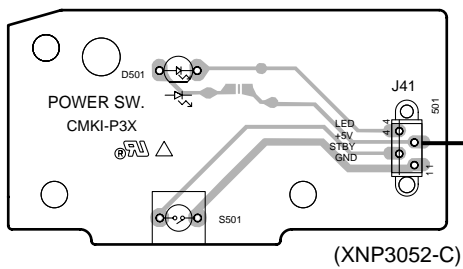
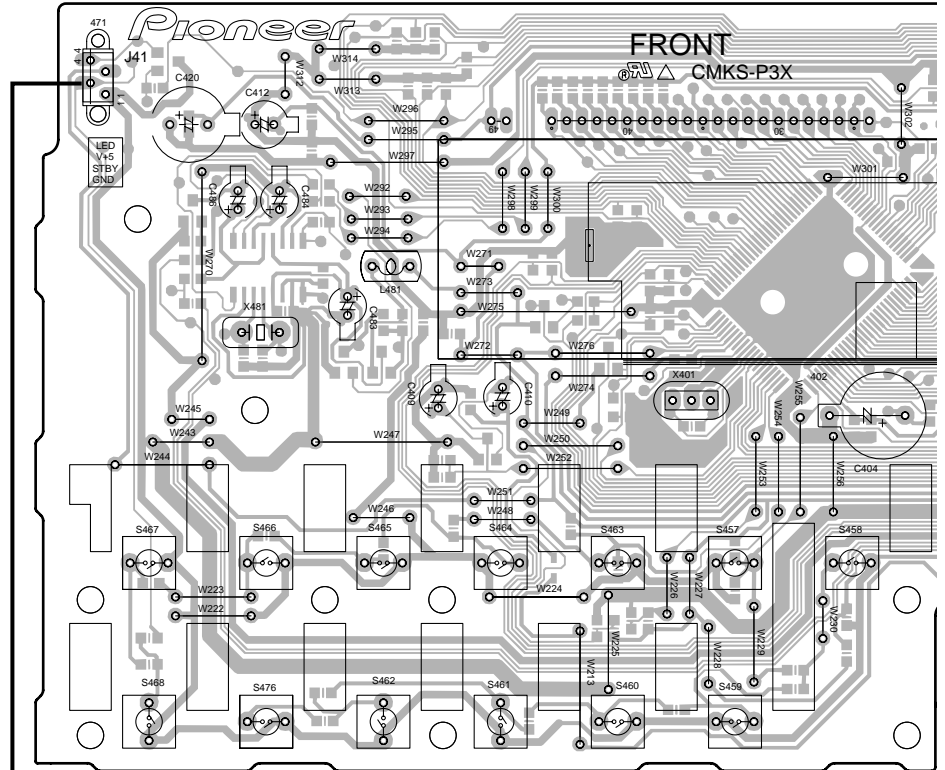

Q POWER SW ASSY

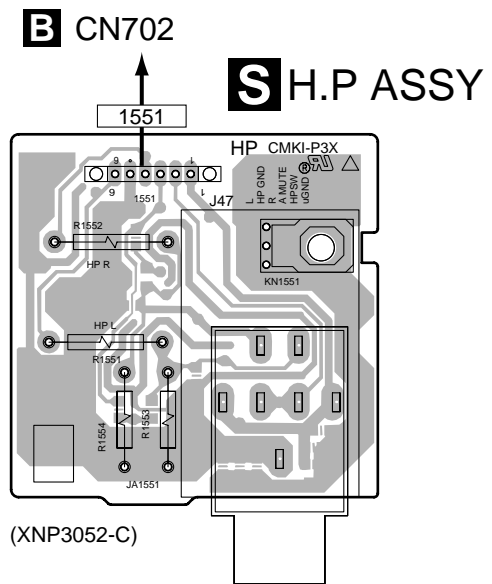

SIDE A

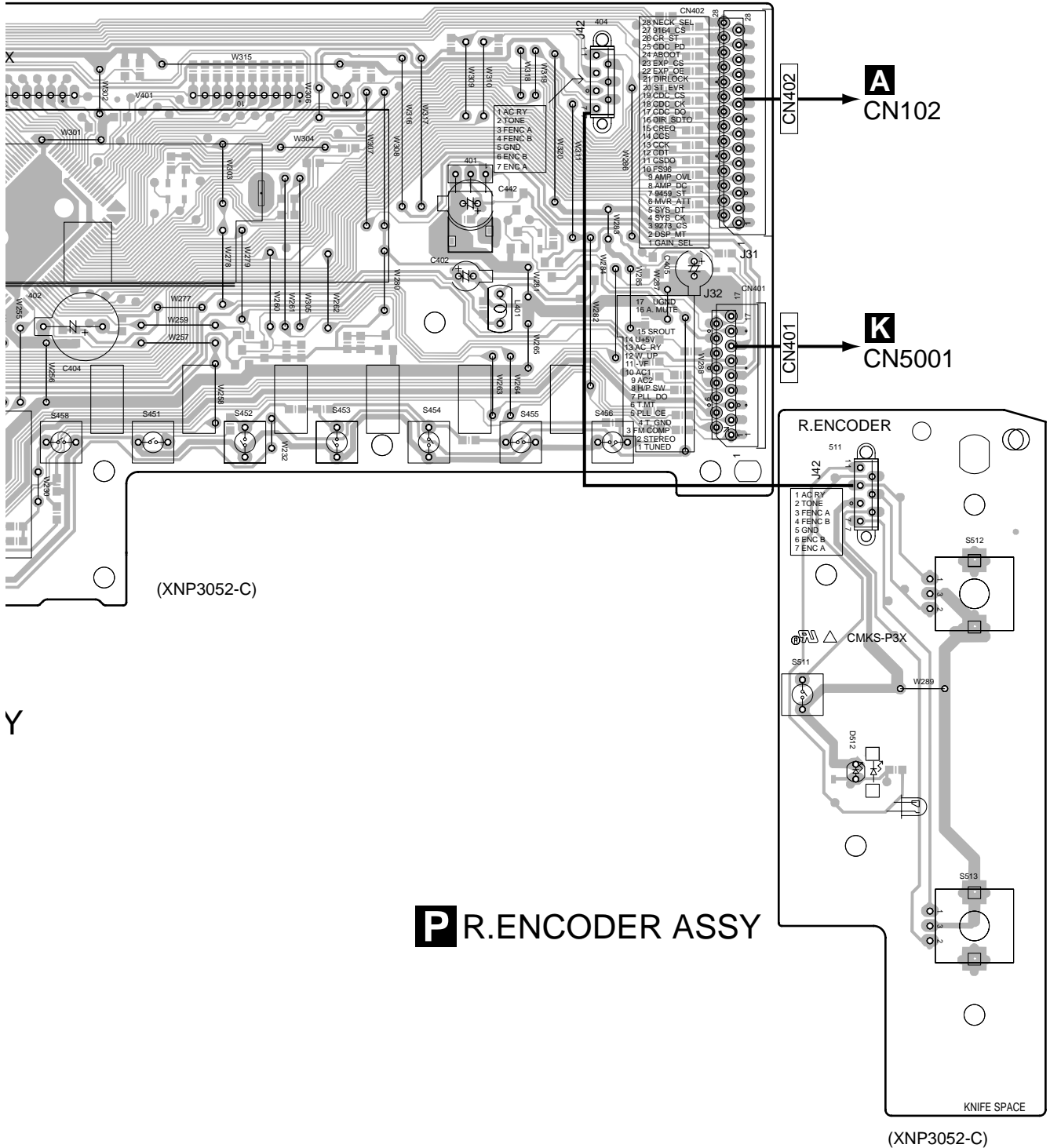

O FRONT ASSY

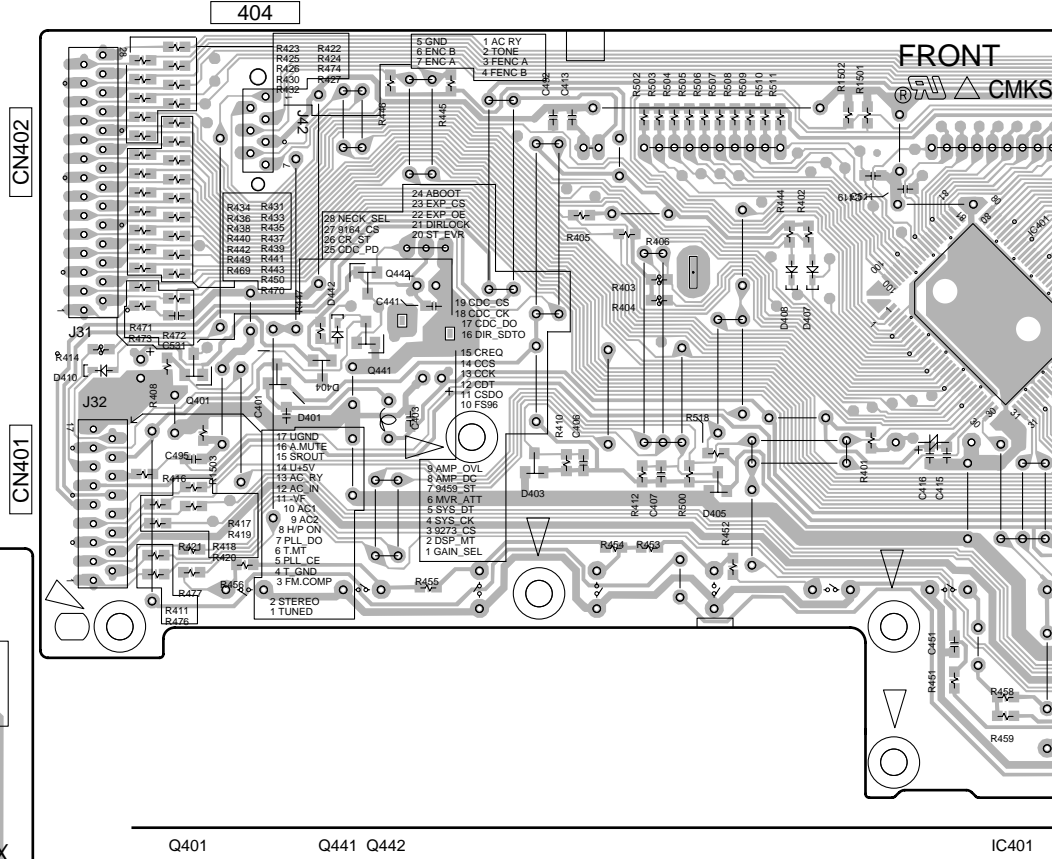

P R.ENCODER ASSY

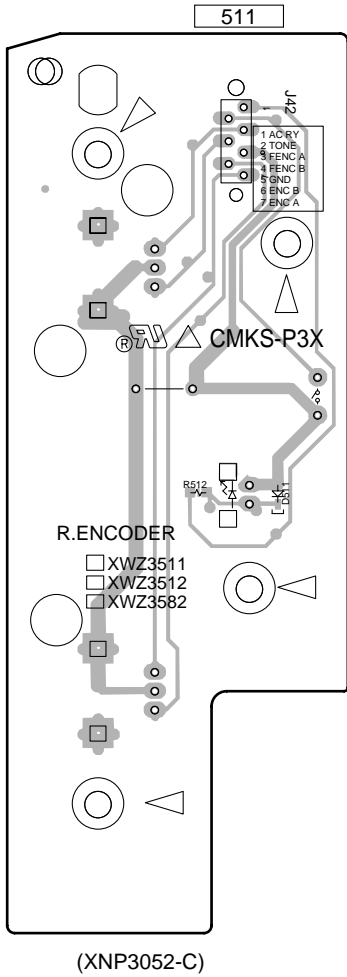

SIDE B

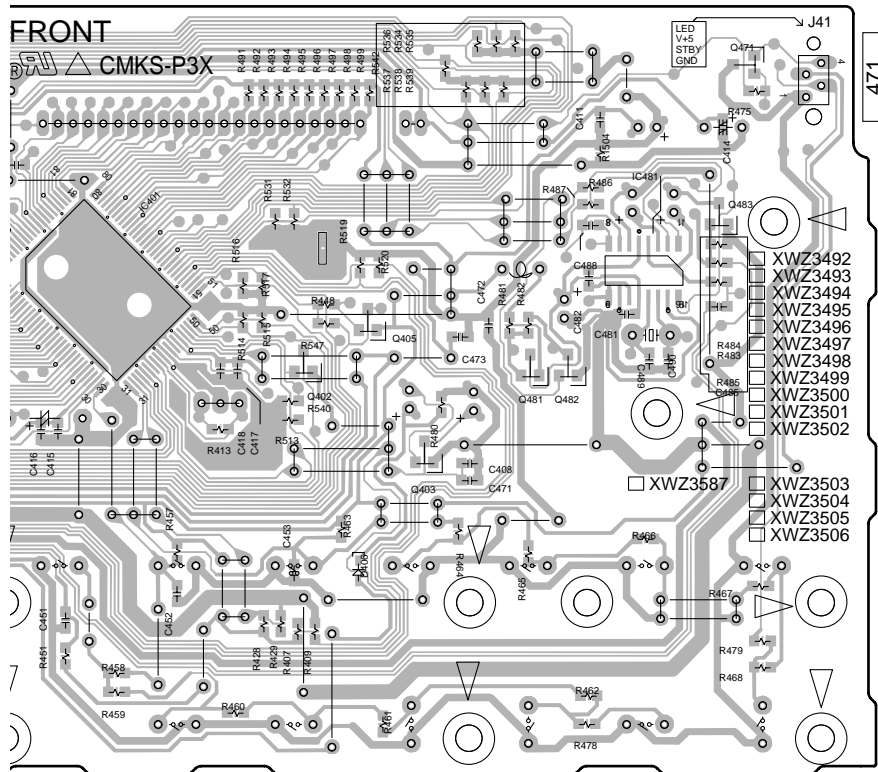

IC401 Q402 Q405 Q403 Q481 Q482 IC481 Q483 Q471

S H.P ASSY

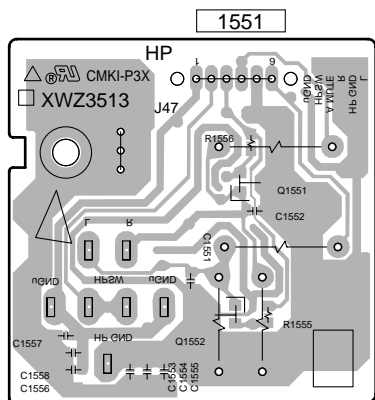

(XNP3052-C)

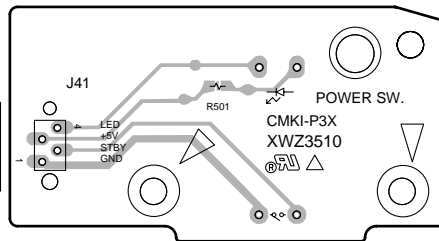

(XNP3052-C)

Q POWER SW ASSY

4.8 FM/AM TUNER MODULE

V FM/AM TUNER MODULE

SIDE A

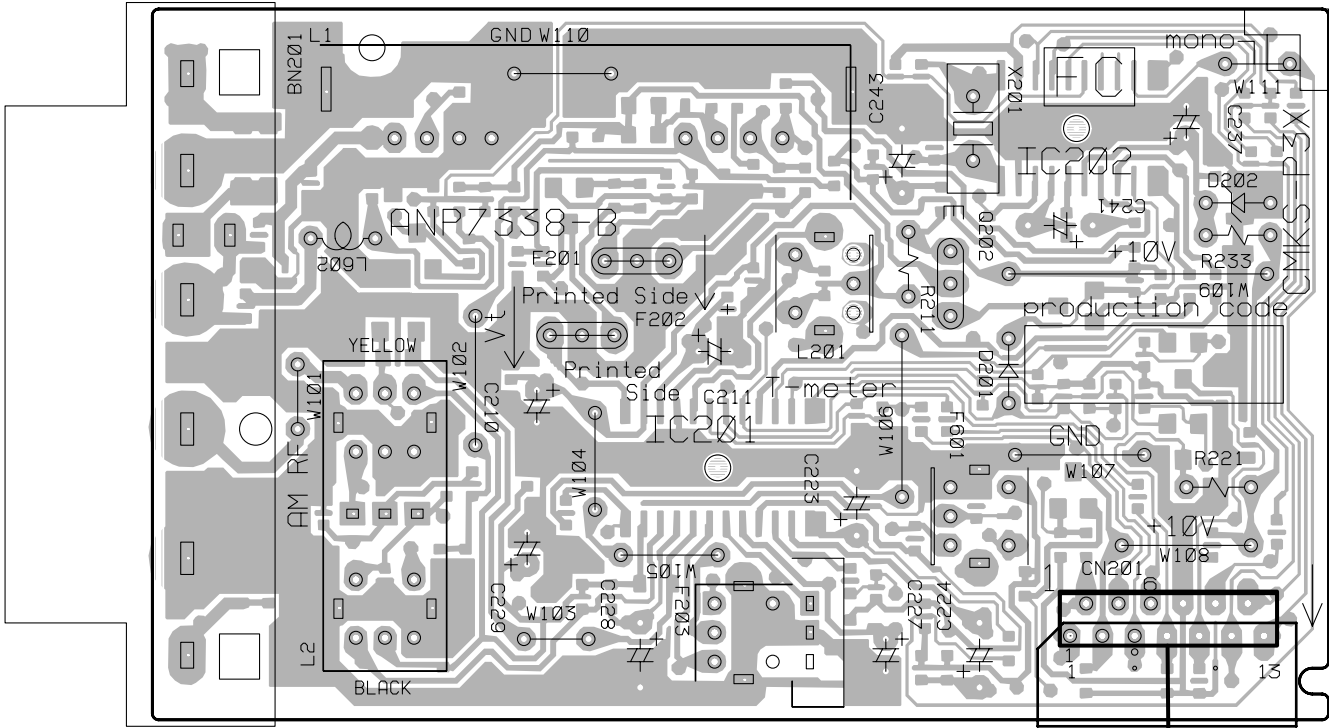

K CN5005 ← CN201 (ANP7338-B)

Q202

V FM/AM TUNER MODULE

SIDE B

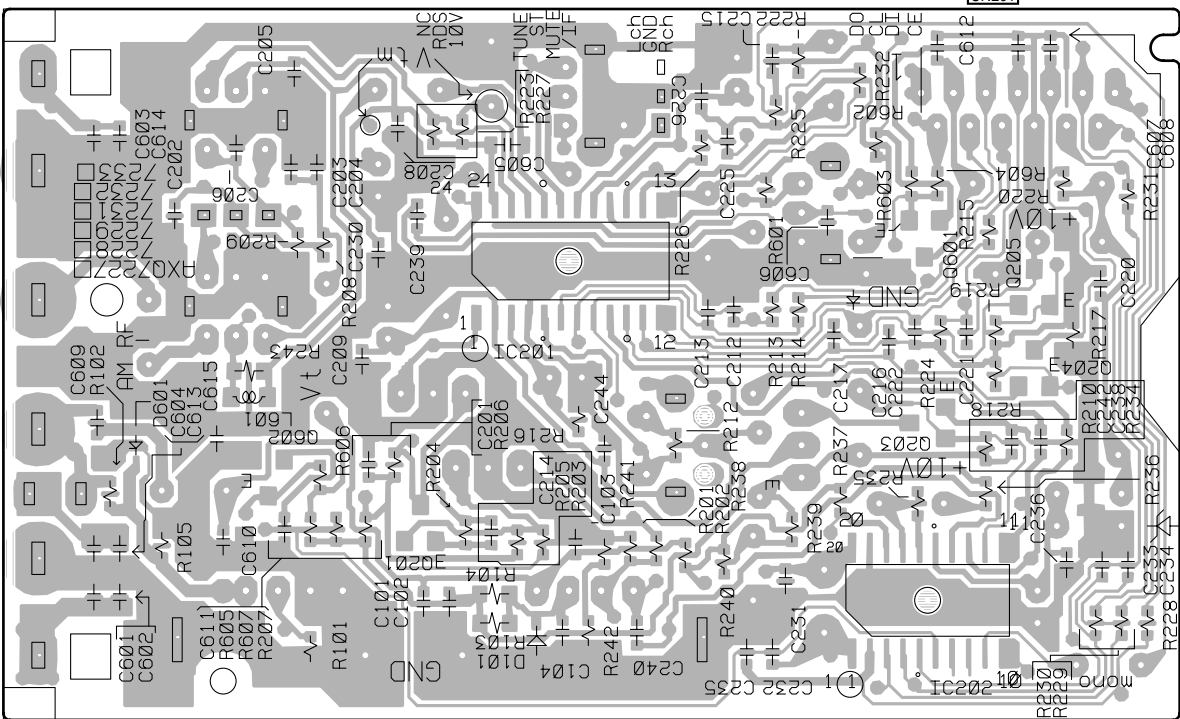

(ANP7338-B)

Q201

IC201

Q203

IC202

Q205

Q204



5. PCB PARTS LIST

NOTES: ●Parts marked by "NSP" are generally unavailable because they are not in our Master Spare Parts List.

●The Δ mark found on some component parts indicates the importance of the safety factor of the part.

Therefore, when replacing, be sure to use parts of identical designation.

●When ordering resistors, first convert resistance values into code form as shown in the following examples.

Ex.1 When there are 2 effective digits (any digit apart from 0), such as 560 ohm and 47k ohm (tolerance is shown by J=5%, and K=10%).

560 Ω → 56 × 10¹ → 561 RD1/4PU 5 6 1 J
 47k Ω → 47 × 10³ → 473 RD1/4PU 4 7 3 J
 0.5 Ω → R50 RN2H R 5 0 K
 1 Ω → 1R0 RSIP 1 R 0 K

Ex.2 When there are 3 effective digits (such as in high precision metal film resistors).

5.62k Ω → 562 × 10¹ → 5621 RN1/4PC 5 6 2 1 F

Mark	No.	Description	Part No.	Mark	No.	Description	Part No.
LIST OF ASSEMBLIES							
		D.D & INPUT ASSY	XWX3047		IC102		NJU7312AM
					IC9601		NJU7313AM
NSP		AMP&PS ASSY	XWK3057		IC9504		PD8097A
		AMP&PRIMARY ASSY	XWZ3537		IC9505		TC74LVX244FT
		TRANS2 ASSY	XWZ3558		IC9502, IC9503		TC74VHC574F
NSP		TRANS3 ASSY	XWZ3561		IC9506		TC74VHCT244AFT
		REGULATOR ASSY	XWZ3545		IC9507		TC7WU04FU
		HASHIGETA ASSY	XWZ3567		IC101		TC9273F-007
		BOARD TO BOARD ASSY	XWZ3575		IC104-IC107, IC9701-IC9705		UPC4570G2
		AMP INPUT ASSY	XWZ3550		IC9707		UPC4570G2
NSP		TRANS1 ASSY	XWZ3553		Q107-Q112, Q9201, Q9202		2SC3326
					Q9101, Q9204, Q9607, Q9609		DTA124EK
NSP		COMPLEX ASSY	XWK3043		Q9610		DTA124EK
		DIGITAL IN ASSY	XWZ3518		Q9102, Q9203, Q9608		DTC124EK
		KAWA ASSY	XWZ3529		D9601, D9602		1SS181
		VIDEO ASSY	XWZ3584		D105, D106, D301, D9921		1SS355
		6CH IN ASSY	XWZ3507		D107, D108		DAN217
		S. VIDEO ASSY	XWZ3522		D201, D202		RB501V-40
		FRONT ASSY	XWZ3498		D104		UDZS5.1B
		R. ENCODER ASSY	XWZ3511		D101, D102		UDZS6.8B
		POWER SW ASSY	XWZ3510	COILS AND FILTERS			
		FRONT VIDEO ASSY	XWZ3515		L9101, L9501, L9504, L9811, L9812		ATL7002
		H.P. ASSY	XWZ3513		L111-L114, L1601, L1602		QTL1013
		TRANS 4 ASSY	XWZ3526		L9102, L9103, L9502, L9503		QTL1013
		MECHA SW ASSY	XWZ3514		L9506, L9507		QTL1013
		FM/AM TUNER MODULE	AXQ7232	CAPACITORS			

AMP & PS ASSY

OTHERS

J44	Jumper wired	D20PYY0325E
J21	Jumper wired	D20PYY0715E

COMPLEX ASSY

OTHERS

J41	Jumper wired	D15A04-100-2651
J42	Jumper wired	D15A07-075-2651
J47	Jumper wired	D20PYY0630E

A D.D & INPUT ASSY

SEMICONDUCTORS

IC9101	AK4586VQ
IC301	BU4094BCF
IC9501	CS493292
IC103	M62446FP
IC9201	NJM2100M
IC9812	NJM2391DL1-25
IC9811	NJM2391DL1-33

C9510, C9511	CCSRCH100D50
C101-C114, C121-C123	CCSRCH101J50
C126-C128, C152-C154	CCSRCH101J50
C197, C198, C207, C208	CCSRCH101J50
C221, C222, C228, C229, C9160	CCSRCH101J50
C9201, C9202	CCSRCH101J50
C9101, C9102	CCSRCH220J50
C235, C9117	CCSRCH221J50
C9509	CCSRCH271J50
C9530, C9731, C9735	CCSRCH331J50

C9103, C9110, C9111, C9114, C9503	CCSRCH471J50
C9505, C9507, C9513, C9515, C9518	CCSRCH471J50
C9520, C9522, C9525, C9528, C9571	CCSRCH471J50
C9611-C9614, C9625, C9639, C9729	CCSRCH471J50
C9815, C9816	CCSRCH471J50

C9707, C9708, C9721, C9722	CCSRCH820J50
C130-C137, C146-C151, C305	CEAT100M50
C9207, C9208, C9523, C9526	CEAT100M50
C9105, C9106, C9108, C9116, C9516	CEAT101M10
C9551, C9792, C9812, C9814	CEAT101M10

VSX-D711-K, VSX-D711-S

Mark	No.	Description	Part No.
	C9740		CEAT220M25
	C9205		CEAT221M6R3
	C9112, C9529, C9769, C9770		CEAT2R2M50
	C9713, C9714, C9727, C9728, C9739		CEAT330M25
	C9765-C9768		CEAT330M25
	C144, C145		CEAT3R3M50
	C117, C118, C225, C226		CEAT470M50
	C232, C233, C239		CEAT470M50
	C155, C156		CEAT471M10
	C115, C116, C234, C240		CEAT4R7M50
	C9203, C9204, C9615-C9618, C9811		CEAT4R7M50
	C9813		CEAT4R7M50
	C271, C9703, C9704, C9717, C9718		CKSRYB102K50
	C119, C120, C124, C125, C138		CKSRYB103K50
	C141, C171, C172, C179, C180		CKSRYB103K50
	C183, C199, C223, C224		CKSRYB103K50
	C230, C231, C237, C238, C304		CKSRYB103K50
	C9104, C9107, C9109, C9121, C9209		CKSRYB103K50
	C9502, C9504, C9506, C9508, C9512		CKSRYB103K50
	C9514, C9517, C9519, C9521, C9524		CKSRYB103K50
	C9527, C9531, C9584, C9636, C9637		CKSRYB103K50
	C9709-C9712, C9723-C9726		CKSRYB103K50
	C9737, C9738, C9817		CKSRYB103K50
	C140, C143, C1631, C1632		CKSRYB104K16
	C173, C174, C9113, C9115, C9126		CKSRYB104K16
	C9206, C9818		CKSRYB104K16
	C9701, C9702, C9715, C9716		CKSRYB222K50
	C9736		CKSRYB223K25
	C139, C142, C9626		CKSRYB223K50
	C236		CKSRYB472K50
	C184, C185, C9732		CKSRYB473K25
	C227, C9730		CKSRYF104Z25

RESISTORS

	R9104	RS1/16S1802F
△	R174, R175	RS1LMF101J
	Other Resistors	RS1/16S□□□□J

OTHERS

CN9101	7P FFC Connector	52044-0745
CN104	9P FFC Connector	52044-0945
CN106	19P FFC Connector	52045-1945
CN102	28P FFC Connector	52045-2845
JA101-JA104	4P Pin Jack	AKB7048
CN107	Connector Post	B3B-PH-K
CN101	16P Socket	KP200TA16L
CN105	8P Socket	KP200TA8L
101-103	PCB Binder	VEF1040
X9501	(27.0MHz)	VSS1086
X9101	(12.288MHz)	VSS1140

B AMP & PRIAMRY ASSY SEMICONDUCTORS

△	IC52 (IC Protector 500mA)	AEK7005
△	IC603 (IC Protector 1A)	AEK7009
△	IC701, IC702 (IC Protector 125mA)	AEK7020
△	IC604-IC607 (IC Protector 10A)	AEK7022
	IC51	NJM78M56FA
△	IC601	PAC010A
△	IC602	PAC011A
	Q703	2SA1145
	Q702	2SB1238X
	Q691, Q692	2SC1740S

Mark	No.	Description	Part No.
	Q704		2SC1845
	Q605, Q606, Q633, Q655, Q656		2SC2240
	Q601-Q604, Q631, Q632		2SC2878
	Q651-Q654		2SC2878
	Q701		2SD1859X
	Q51		KRC101M
	D56, D57, D601-D604		1SS133
	D631, D632, D651-D654		1SS133
	D751, D752, D755-D758		1SS133
△	D701, D702		D5SBA20(B)
	D711		MTZJ22D
	D58		MTZJ5.1A
	D712		MTZJ5.1B
	D605, D606, D633, D634		MTZJ8.2A
△	D51-D55, D721-D724		S5688G

COILS AND FILTERS

△	L51	Line Filter	ATF7018
	L751-L753, L761, L762	Choke Coil	ATH1004

SWITCHES AND RELAYS

	RY751-RY754	Relay	XSR3002
△	RY51	JOE Lowpower Relay	XSR3003

CAPACITORS

△	C707, C708	(0.01μF/AC125V)	ACG1005
	C51, C52	(0.01μF/AC125V)	ACG7020
	C701, C702	(4700μF/63V)	ACH7134
	C703, C704	(3300μF/42V)	ACH7135
	C607-C610, C634, C635		CCPUCH6R8K50
	C657-C660		CCPUCH6R8K50
	C615, C616, C638, C665, C666		CEANP2R2M50
	C775, C776		CEANP470M50
	C705, C706		CEAT100M2A
	C712		CEAT101M10
	C611, C612, C636, C661, C662		CEAT101M16
	C711		CEAT101M35
	C53		CEAT102M16
	C692		CEAT221M10
	C54		CEAT470M25

	C605, C606, C633, C655, C656		CEAT4R7M50
	C751-C756, C761-C764		CFTYA224J50
	C613, C614, C637, C663, C664		CKPUYB101K50
	C601, C602, C631, C651, C652		CKPUYB102K50
	C691, C769, C770		CKPUYB102K50

	C603, C604, C632, C653, C654		CKPUYB331K50
	C55-C57		CKPUYF103Z25
	C757-C759, C765-C768		CQMB472J50

RESISTORS

△	R52	RD1/2PM270J
△	R751, R752, R755, R761, R762	RD1/4PUF101J
△	R753, R754, R756, R763, R764	RS1LMF4R7J
△	R711	RS2LMF332J
△	R615, R616, R638, R665 (0.22Ω/5W)	XCN3001
	R666 (0.22Ω/5W)	XCN3001
	Other Resistors	RD1/4PU□□□□J

OTHERS

52	3P Cable Holder	51048-0300
CN53	23P FFC Connector	52045-2345
CN702	6P Jumper Connector	52147-0610
CN753	1P Pin Jack	AKB7042
H51, H52	Fuse Clip	AKR7001

Mark	No.	Description	Part No.
△	T51	Standby Transformer	ATT7037
	CN601	16P Plug	KM200TA16
	CN51	AC Code Socket	RKP1751
	KN51, KN601	Earth Metal Fitting	VNF1084
	CN752	Speaker Terminal 8P	XKE3017
	CN751	Speaker Terminal 6P	XKE3018
	701	7P Cable Holder	XKP3047

C TRANS 2 ASSY

SEMICONDUCTORS

△	IC853	(IC Protector 1.6A)	AEK7012
△	IC851, IC852	(IC Protector 4A)	AEK7018

OTHERS

851	7P Cable Holder	XKP3047
-----	-----------------	---------

D TRANS 3 ASSY

TRANS 3 ASSY has no service part.

E REGULATOR ASSY

SEMICONDUCTORS

IC803, IC804	NJM78M05FA
IC801, IC805	NJM78M12FA
IC802	NJM79M12FA
Q801, Q803, Q805	KRA103M
Q802, Q804, Q806	KRC102M

△	D809, D810	MTZJ6.2A
	D801-D804	S5688G

CAPACITORS

C808, C811	CEAT101M10
C805, C806, C813	CEAT101M16
C801, C802	CEAT222M25
C809	CEAT332M16
C803, C804, C807, C810, C812	CKPUYF103Z25

OTHERS

CN801	23P FFC Connector	52045-2345
CN804	13P Plug	KM200TA13
CN802	16P Plug	KM200TA16
CN803	6P Plug	KM200TA6

F HASHIGETA ASSY

OTHERS

CN1001, CN1002	8P Plug	KM200TA8
----------------	---------	----------

G BOARD TO BOARD ASSY

OTHERS

CN391	11P Plug	KM200TA11
CN390	13P Plug	KM200TA13

H AMP INPUT ASSY

SEMICONDUCTORS

IC251	NJM4558D-D
Q257	2SA933S
Q251, Q256	2SC2878
Q252	2SD1858X
Q254	KRA103M

Q253, Q255	KRC103M
------------	---------

Mark	No.	Description	Part No.
	D251, D252		1SS133
	D253		MTZJ27D
	D254		MTZJ5.1B

CAPACITORS

C251	CEANP470M25
C254	CEAT101M25
C252, C253	CKPUYF103Z25

RESISTORS

Other Resistors	RD1/4PU□□□J
-----------------	-------------

OTHERS

CN251	3P FFC Connector	52044-0345
CN254	19P FFC Connector	52044-1945
CN252	3P Plug	KM250MA3L
CN253	16P Socket	KP200TA16L

I TRANS 1 ASSY

TRANS 1 ASSY has no service part.

J DIGITAL IN ASSY

SEMICONDUCTORS

IC1901	TC74ACT151F
IC1902, IC1903	TC74HCU04AF

COILS AND FILTERS

F1901-F1903	Chip Bead	DTF1067
L1904, L1905	Chip Solid Inductor	QTL1013

CAPACITORS

C1918	CCSRCH221J50
C1907, C1914, C1928	CCSRCH271J50
C1911, C1925	CCSRCH470J50
C1916, C1926	CCSRCH471J50
C1904, C1905, C1912	CEAT101M10

C1915	CKSRYB102K50
C1906, C1910, C1913, C1919, C1920	CKSRYB103K50
C1923, C1929	CKSRYB103K50
C1902, C1903, C1908, C1909	CKSRYB104K25
C1921, C1922	CKSRYB104K25

RESISTORS

Other Resistors	RS1/16S□□□J
-----------------	-------------

OTHERS

CN1901	7P FFC Connector	52045-0745
JA1904	Opt. Link Out 12MB/s	JFJ3000-010020
JA1902	Opt. Link In 12MB/s	JFJ4000-010020
JA1901, JA1907	1P Pin Jack	VKB1077

K KAWA ASSY

SEMICONDUCTORS

IC5001	BU4094BCF
Q5001	2SC1740S
Q5020-Q5022	DTC114TK
Q5002	DTC143EK
D5001, D5002	1SS355

COILS AND FILTERS

L5001	Chip Solid Inductor	QTL1013
-------	---------------------	---------

VSX-D711-K, VSX-D711-S

Mark	No.	Description	Part No.
------	-----	-------------	----------

CAPACITORS

C5004-C5007	CCSRCH101J50
C5012	CCSRCH471J50
C5001, C5002	CEAT100M50
C5003	CEAT101M16
C5009	CKSRYP103K50

C5011	CKSRYP104K16
C5010	CKSRYP105Z10

RESISTORS

Other Resistors	RS1/16S□□□J
-----------------	-------------

OTHERS

CN5004	7P FFC Connector	52044-0745
CN5005	13P FFC Connector	52044-1345
CN5001	17P FFC Connector	52044-1745
CN5002	13P Socket	KP200TA13L
CN5003	8P Socket	KP200TA8L

5001	Screw Plate	VNE1948
------	-------------	---------

L VIDEO ASSY SEMICONDUCTORS

IC301	NJM2296M
Q302	2SA1515
Q303	2SC3326
Q301	2SC3377
D301, D302, D305, D306	1SS355

D303, D304	UDZS6.2B
------------	----------

CAPACITORS

C347	CCSRCH470J50
C307-C310, C312, C314, C338	CEAT470M25
C1360, C302	CKSRYP103K50
C339, C340	CKSRYP104K25
C304-C306	CKSRYP221K50

C333	CKSRYP331K50
C311, C313	CKSRYP473K25

RESISTORS

△ R313, R316	RS3LMF560J
Other Resistors	RS1/16S□□□J

OTHERS

CN303	7P FFC Connector	52044-0745
CN305	6P Pin Jack	AKB7123
CN301	13P Socket	KP200TA13L
CN302	6P Socket	KP200TA6L

M 6CH IN ASSY SEMICONDUCTORS

IC302, IC303	NJM4558MD
--------------	-----------

CAPACITORS

C319, C320, C327, C328	CCSRCH101J50
C342-C345	CCSRCH101J50
C321, C324, C331, C332	CEAT4R7M50
C316, C322, C323, C329, C330	CKSRYP103K50
C317, C318, C325, C326	CKSRYP221K50

RESISTORS

Other Resistors	RS1/16S□□□J
-----------------	-------------

Mark	No.	Description	Part No.
------	-----	-------------	----------

OTHERS

CN307	9P FFC Connector	52044-0945
CN309	4P Pin Jack	AKB7087

N S. VIDEO ASSY

SEMICONDUCTORS

IC351, IC352	NJM2296M
D351-D354	1SS355

CAPACITORS

C375, C376	CCSRCH470J50
C352, C355, C358, C361-C363	CEAT470M25
C366	CEAT470M25
C372, C373, C378	CKSRYP103K50
C351, C353, C354, C356, C357	CKSRYP104K25

C359, C367	CKSRYP104K25
C364, C365, C368-C371	CKSRYP221K50

RESISTORS

Other Resistors	RS1/16S□□□J
-----------------	-------------

OTHERS

CN353	Mini DIN Socket	AKP7020
CN352	Mini DIN Socket	AKP7043
CN354	Connector Post	B5B-PH-K
CN351	11P Socket	KP200TA11L
JA351	Remote Control Jack	RKN1004

O FRONT ASSY SEMICONDUCTORS

IC481	BU1923F
IC401	PDG268B
Q481	2SA1037K
Q483	2SC3326
Q401, Q402, Q442, Q471	DTA124EK

Q403, Q441, Q482	DTC143EK
D406, D410, D442	1SS355
D403, D405	DAN217
D401, D404	DAP202K
D407, D408	RB501V-40

COILS AND FILTERS

L401, L481	LFEA2R2J
------------	----------

SWITCHES AND RELAYS

S451-S468, S476	ASG1051
-----------------	---------

CAPACITORS

C420 (220μF/35V)	ACH7101
C404 (0.22F/5.5V)	ACH7132
C489, C490	CCSRCH270J50
C511	CCSRCH471J50
C488	CCSRCH561J50

C442	CEAL470M10
C483	CEAT101M10
C486	CEAT1R0M50
C402	CEAT221M6R3
C409, C410, C484	CEAT2R2M50

C412	CEAT470M50
C405	CEAT471M6R3
C451-C453, C472, C481, C482	CKSRYP102K50
C492, C495	CKSRYP102K50
C401, C403, C411, C419, C441	CKSRYP103K50

Mark	No.	Description	Part No.
	C531		CKSRYB103K50
	C408, C416, C418, C471		CKSRYB104K16
	C485		CKSRYB472K50
	C406, C407		CKSRYB473K16

RESISTORS

Other Resistors	RS1/16S□□□J
-----------------	-------------

OTHERS

471	4P Cable Holder	51063-0405
404	7P Cable Holder	51063-0705
CN401	17P FFC Connector	52044-1745
CN402	28P FFC Connector	52044-2845
V401	FL Tube	XAV3013
401	Remote Receiver Unit	GP1U27X
X481	(4.332MHz)	ASS7004
X401	(7.2MHz)	ASS7039

**P R. ENCODER ASSY
SWITCHES AND RELAYS**

S511		ASG1051
S513	Rotary Encoder	XSX3005
S512	Rotary Encoder	XSX3006

OTHERS

511	7P Cable Holder	51063-0705
-----	-----------------	------------

**Q POWER SW ASSY
SEMICONDUCTORS**

D501	BR3371XJ30A
------	-------------

SWITCHES AND RELAYS

S501	ASG1051
------	---------

RESISTORS

Other Resistors	RS1/16S□□□J
-----------------	-------------

OTHERS

501	4P Cable Holder	51063-0405
-----	-----------------	------------

**R FRONT VIDEO ASSY
CAPACITORS**

C903, C905	CEAL470M25
C908, C911, C914	CKSRYB103K50
C904, C906, C909, C912	CKSRYB104K25
C901, C902	CKSRYB221K50
C907, C910, C913	CKSRYB471K50

RESISTORS

Other Resistors	RS1/16S□□□J
-----------------	-------------

OTHERS

JA902	Front Pin Jack 4P	AKX7014
-------	-------------------	---------

**S H.P. ASSY
SEMICONDUCTORS**

Q1551, Q1552	2SC3326
--------------	---------

CAPACITORS

C1554, C1557	CCSRCH471J50
C1553, C1556	CKSRYB103K50

Mark	No.	Description	Part No.
	C1555, C1558		CKSRYB104K16
	C1551, C1552		CKSRYB223K50

RESISTORS

△	R1553, R1554	RS1LMF471J
△	R1551, R1552	RS2LMF331J
	Other Resistors	RS1/16S□□□J

OTHERS

1551	6P Cable Holder	51048-0600
JA1551	Headphone Jack	RKB1014
KN1551	Earth Metal Fitting	VNF1084

**T TRANS 4 ASSY
SEMICONDUCTORS**

△	IC891, IC892 (IC Protector 630mA)	AEK7006
	D891	S1WB(A)60SD

CAPACITORS

C891, C892	CEAT471M35
------------	------------

OTHERS

CN891	3P FFC Connector	52045-0345
-------	------------------	------------

**U MECHA SW ASSY
SWITCHES AND RELAYS**

S591	Push Switch	ASG7014
------	-------------	---------

CAPACITORS

C591, C592	CKSRYB103K50
------------	--------------

OTHERS

CN591	3P Jumper Connector	52151-0310
-------	---------------------	------------

**V FM/AM TUNER MODULE
SEMICONDUCTORS**

IC201	BA1451F
IC202	LC72131MD
Q201, Q204, Q205, Q601	2SC2412K
Q202	DTA124ES
Q203, Q602	DTC124EK
D201	1SS133
D601	HVU187
D202	MTZJ5.1C
D101	UDZS6.8B

COILS AND FILTERS

L201	FM Dector Coil 10.7MHz	ATE7003
F202	Ceramic Filter	ATF-107
F201	Ceramic Filter	ATF-119
F601	Antibirdy Filter	ATF7025
F203	AM Ceramic Filter 450kHz	ATF7026

L602	LAU2R2J
L601	LCTA270J2520

CAPACITORS

C605	CCSQCH680J50
C212, C213, C226, C233-C235	CCSRCH101J50
C240, C614	CCSRCH101J50
C206	CCSRCH120D50
C231, C232	CCSRCH150J50

VSX-D711-K, VSX-D711-S

Mark	No.	Description	Part No.
	C223		CEAT100M50
	C229		CEAT101M10
	C224		CEAT1R0M50
	C227		CEAT220M25
	C241		CEAT2R2M50
	C243		CEAT330M16
	C228		CEAT3R3M50
	C237		CEAT470M10
	C211		CEJA1R0M50
	C210		CEJA470M16
	C103, C104, C204, C238, C609		CKSRYB102K50
	C102, C208, C216, C217, C220		CKSRYB103K50
	C239, C242, C604, C610, C615		CKSRYB103K50
	C225		CKSRYB153K50
	C607, C608		CKSRYB182K50
	C201, C205, C214, C230, C236		CKSRYB223K50
	C244, C611		CKSRYB223K50
	C221		CKSRYB224K10
	C603		CKSRYB392K50
	C215		CKSRYB471K50
	C202, C222		CKSRYB473K16
	C606		CKSRYB561K16

RESISTORS

R211	RD1/4PU221J
R221	RD1/4PU222J
R233	RD1/4PU391J
R243	RS1/10S0R0J
R103, R104	RS1/10S221J
Other Resistors	RS1/16S□□□J

OTHERS

CN201	13P FFC Connector	52044-1345
BN201	2P Terminal	AKA7002
	SHIELD CASE T	ANK7072
	SHIELD CASE B	ANK7073
X201	(7.2000MHz)	ASS1093
	FM FRONTEND	AXF7005
	AM RF TUNING BLOCK	AXX7072

6. ADJUSTMENT



■ AM Tuner Section

- There is no adjustment in the AM tuner.

■ FM Tuner Section

- Set the mode selector to FM BAND.
- Connect the wiring as shown in Fig. 1.

Note : Even if the TUNER MODULE is disconnected, other functions can operate.

[ANT. INPUT SIGNAL]

- Frequency : 98 MHz
- Modulation : OFF
- Input Level : 80 dB μ V

Step No.	Adjustment Title	Adjustment point	Measurement point	Adjustment value	Adjustment State
1	T-METER Adjustment	L201	IC201 Pin 21/Pin23	$0 \pm 50\text{mV}$	Adjust L201 so that the DC voltage between Pin 21 and Pin 23 of IC201 (Test point "Vtm") gets within $0 \pm 50\text{mV}$.

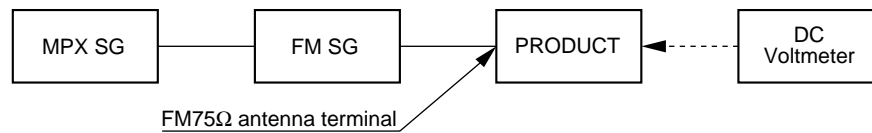
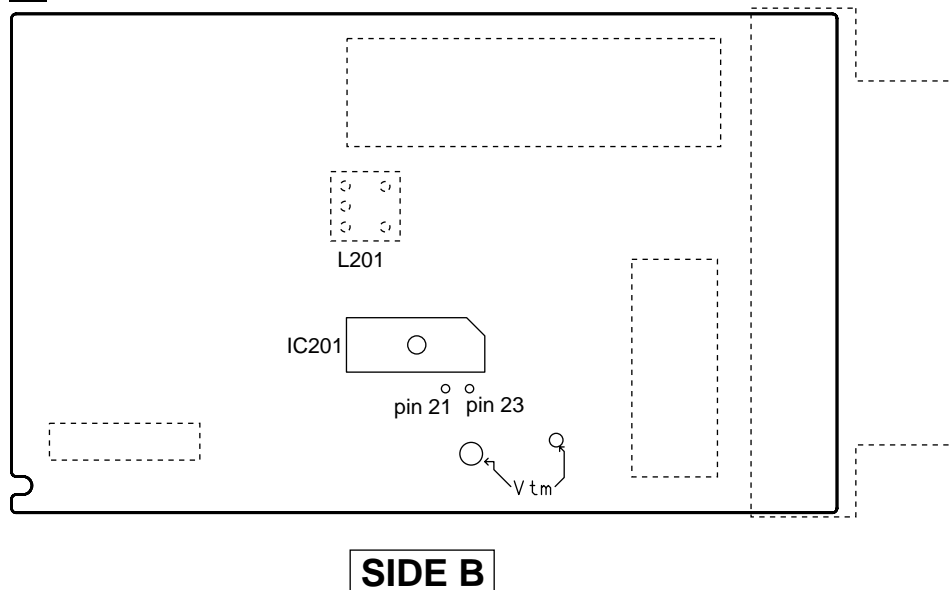

Fig.1 Adjustment Wiring Diagram

V FM/AM TUNER MODULE



SIDE B

Fig.2 Adjustment Point

7. GENERAL INFORMATION

7.1 DIAGNOSIS

7.1.1 U-COM BLOCKDIAGRAM

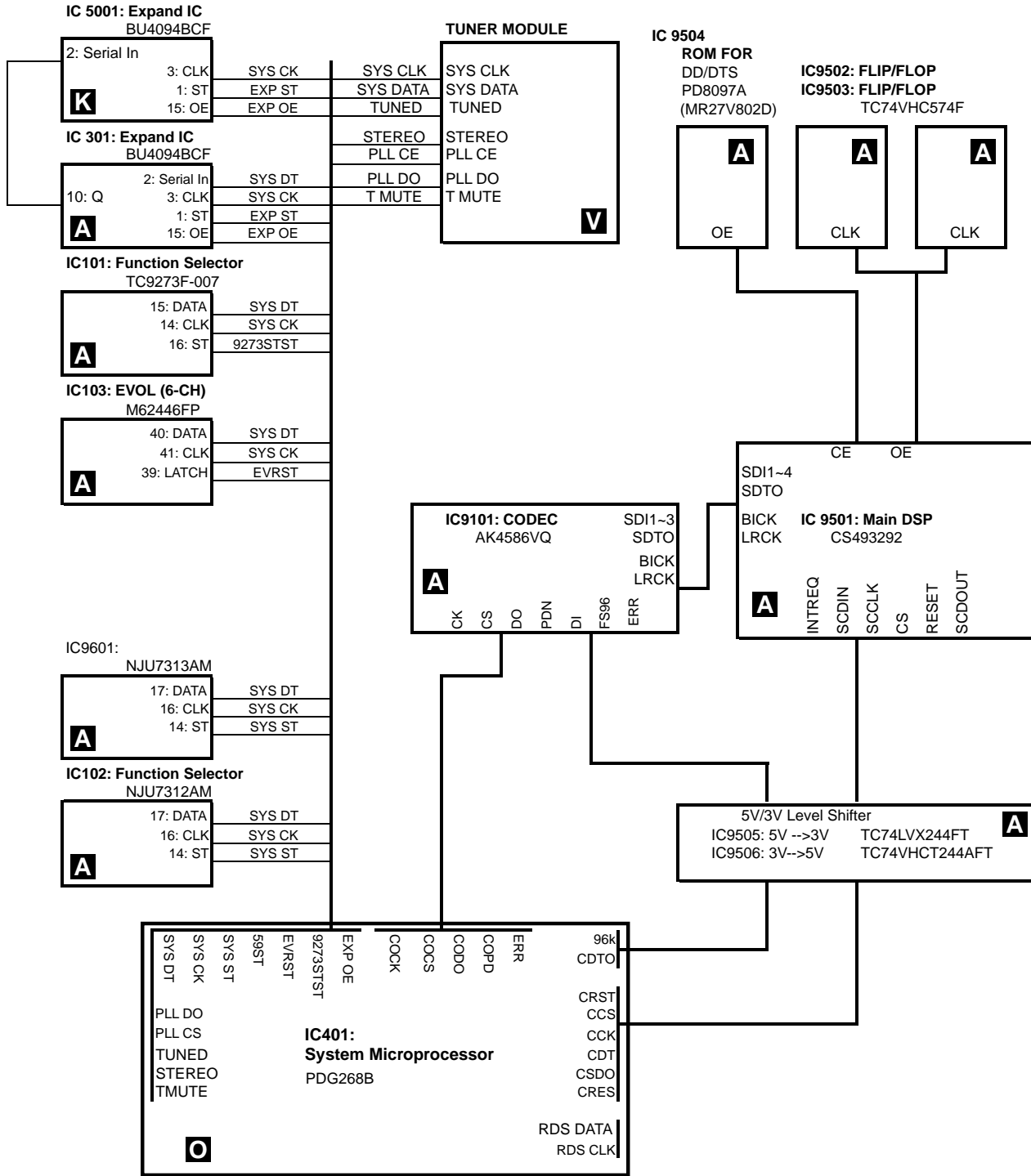

7.1.2 POWER ON AND OFF SEQUENCE

■ POWER ON SEQUENCE

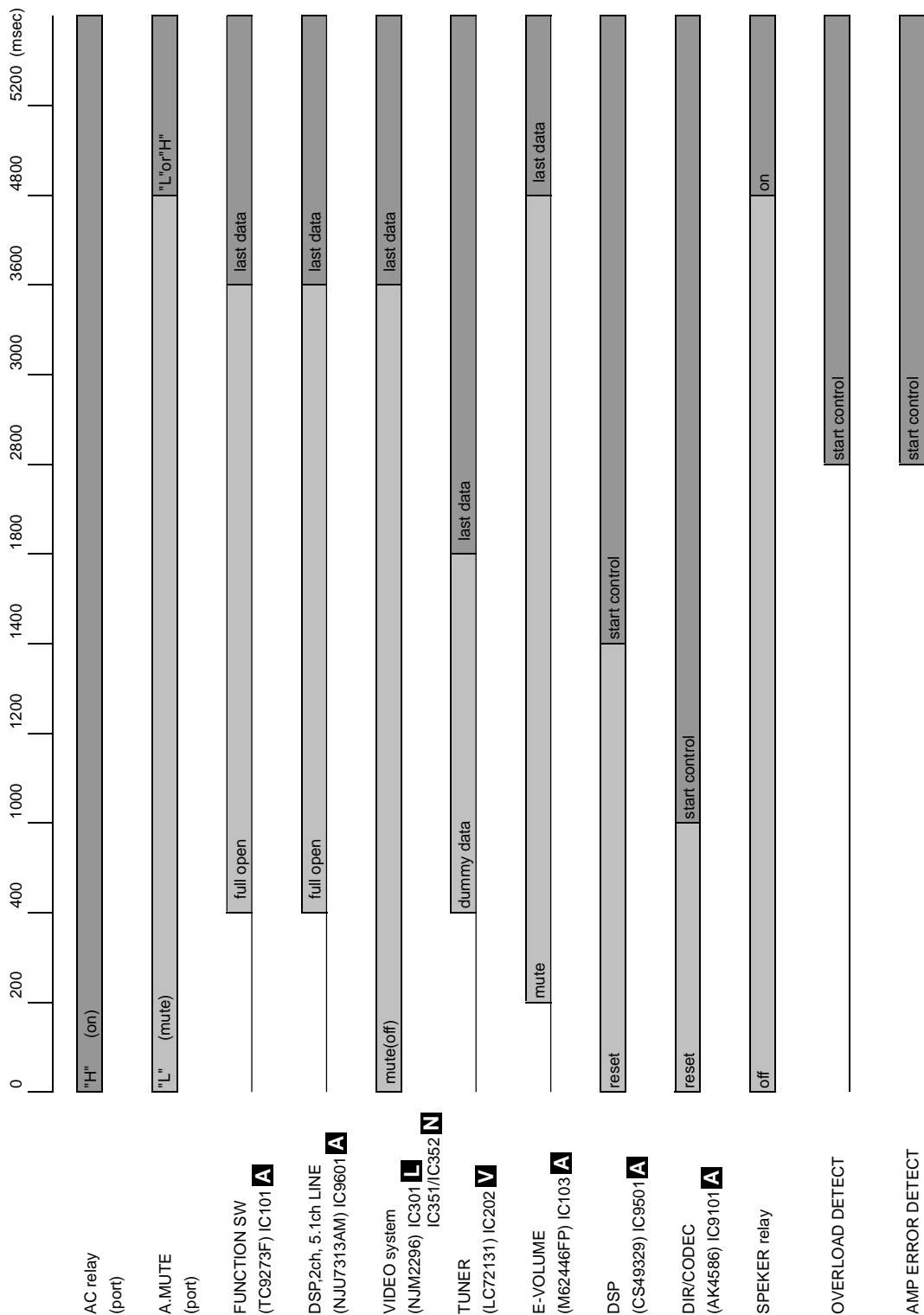

■ POWER OFF SEQUENCE

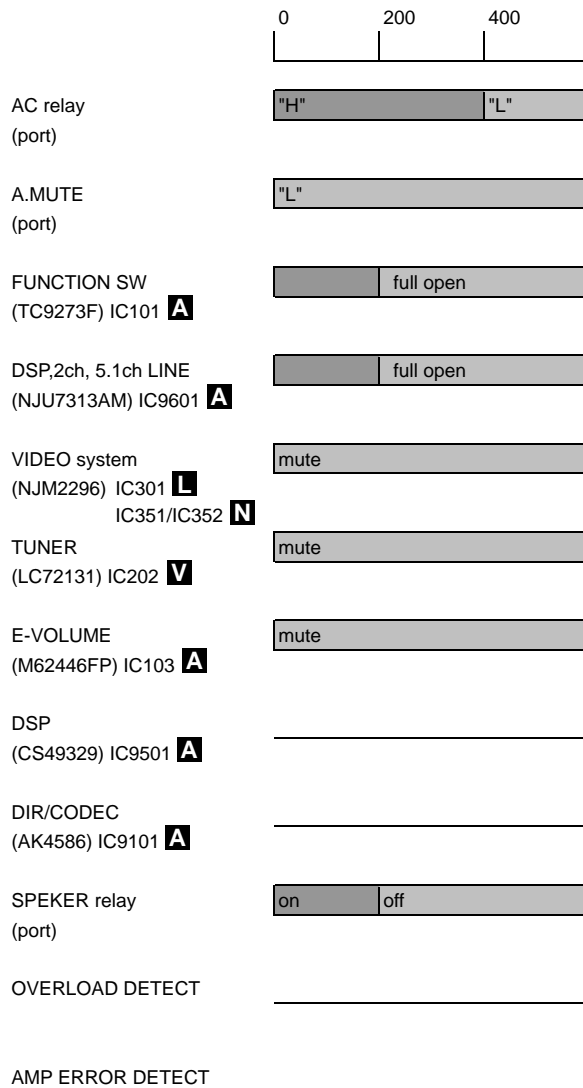

7.1.3 PROTECTION CIRCUIT

1. DC abnormal detection

It processes more preferentially than overload detection.

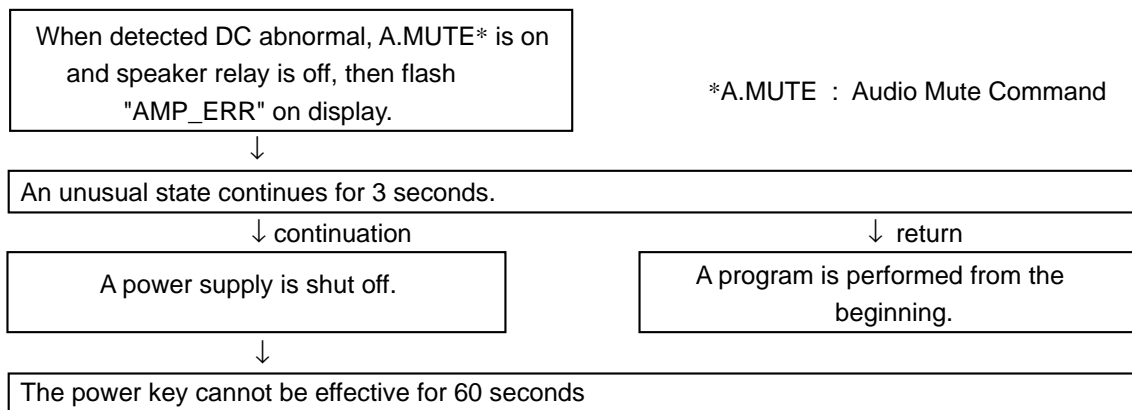

If the AC plug is pulled off within 60 sec, and then it is plugged in again, the unit will be reset for 60 sec.

2. Overload detection

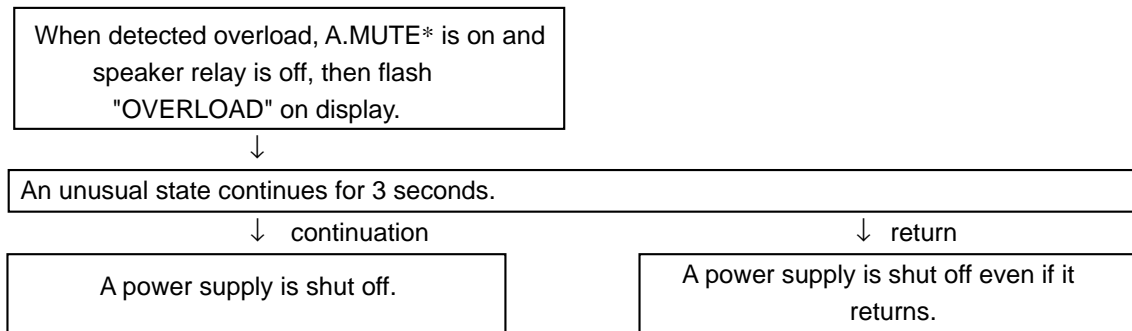

7.1.4 PCB LOCATION

■ PCB Location

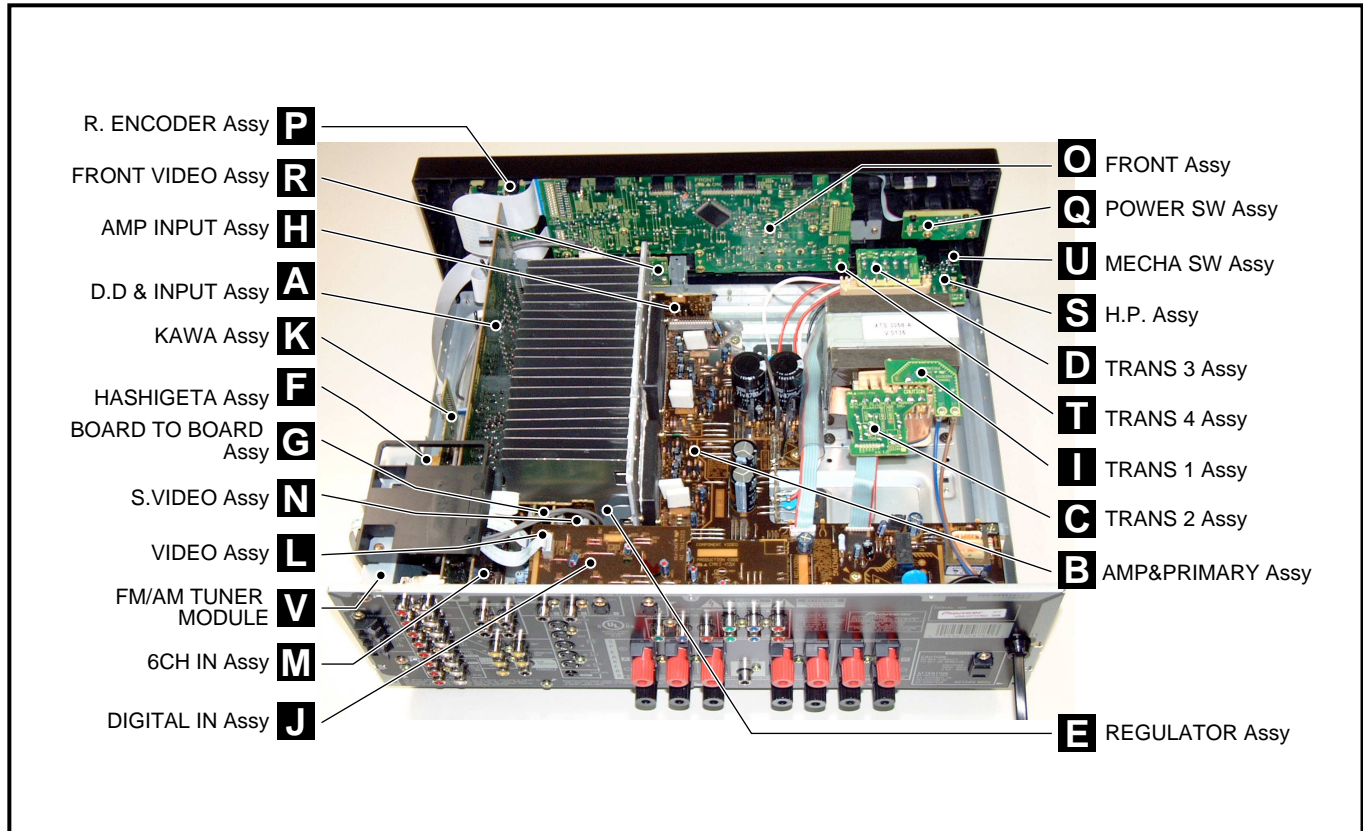

Note : D.D & INPUT Assy
 The pin of function IC (IC101 TC9273F-007) can be checked from side-A by the through-hole round.
 The pin No. is printed on the side-A. (Refer to P.41.)

Even if the FM/AM TUNER MODULE is disconnected, other functions can operate.

7.2 PARTS

7.2.1 IC

• The information shown in the list is basic information and may not correspond exactly to that shown in the schematic diagrams.

• List of IC

PDG268A, AK4586VQ, BD3812F, NJU7312AM, PD8097A, AK4382

■ PDG268A (FRONT ASSY : IC401)

• System Control MCU

■ Pin Arrangement (Top View)

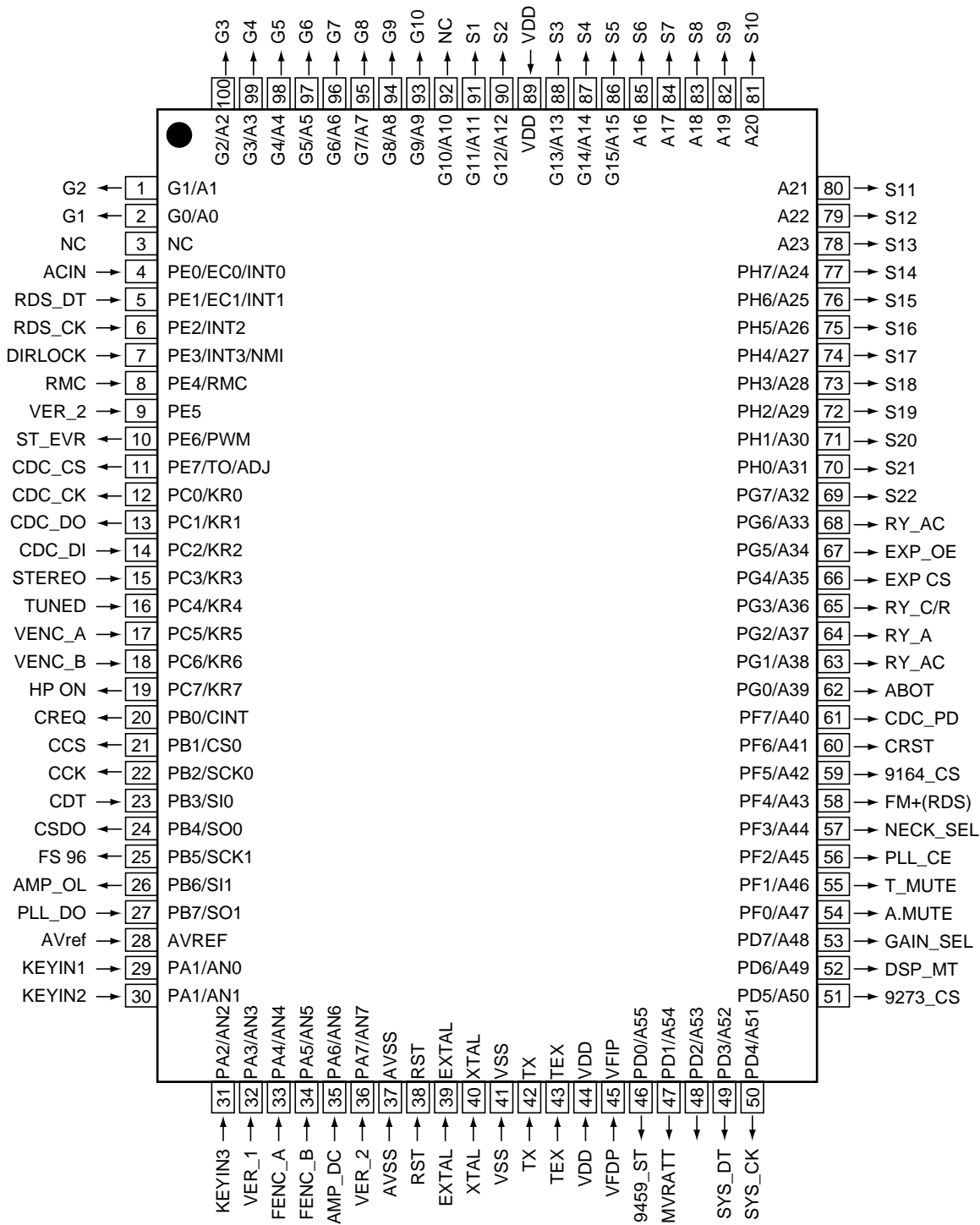

VSX-D711-K, VSX-D711-S

• Pin Function

No.	Pin Name	I/O	Pin Function	Active
1	G2	O	Grid output 2	H
2	G1	O	Grid output 1	H
3	NC	–	Connect to Vdd	
4	ACIN	I	Input AC pulse	
5	RDS_DT	I	Serial control DATA signal of RDS communication	
6	RDS_CK	I	Serial control CLOCK signal of RDS communication (Use external interrupt)	
7	DIRLOCK	I	ERR/OVER input from CODEC	
8	RMC	I	Remote control signal input (no-carrier signal)	
9	VER_2	I	Destination switch 2	
10	ST_EVR	O	Strobe of communication for E-volume	H
11	CDC_CS	O	Chip select for CODEC	
12	CDC_CK	O	Control clock for CODEC & TC9164	
13	CDC_DO	O	Control data for CODEC & TC9164	
14	CDC DI	I	Data input from DIR	
15	STEREO	I	Signal to switch Stereo / Monoral	
16	TUNED	I	Condition of TUNED	
17	VENC_A	I	Input from rotary encoder of E-volume (A)	
18	VENC_B	I	Input from rotary encoder of E-volume (B)	
19	HP ON	I	Headphone detect	L
20	CREQ	I	Request for DSP	L
21	CCS	O	Chip select for DSP	L
22	CCK	O	Clock signal for DSP	H
23	CDT	I	DATA input signal for DSP	
24	CSDO	O	DATA output signal for DSP	H
25	FS 96	I	96 k	H
26	AMP_OL	I	Detect overload of protection circuit (L: overload)	H
27	PLL_DO	I	Data input signal for communication with LC72131 (Tuner)	
28	AVref	–	Connect to Vdd	
29	KEYIN1	I	Key input A/D conversion port 1	
30	KEYIN2	I	Key input A/D conversion port 2	
31	KEYIN3	I	Key input A/D conversion port 3	
32	VER_1	I	Input 1 to switch region (A/D input)	
33	FENC_A	I	FUNC Rotary encoder signal input (A)	
34	FENC_B	I	FUNC Rotary encoder signal input (B)	
35	AMP_DC	I	Detect trouble DC of protection circuit (L : Trouble)	L
36	VER_2	I	Input 2 to switch region (A/D input)	L
37	AVSS	–	Connect to Vss	
38	RST	–	Reset	
39	EXTAL	–	Connect to the oscillator (7.2MHz)	
40	XTAL	–		
41	VSS	–	Connect to Vss	
42	TX	–	NC	
43	TEX	–	Connect to Vss	
44	VDD	–	+5V	
45	VFDP	–	-30V	
46	9459_ST	O	Strobe for E-volume (TC9459) of SB	
47	MVRATT	O	ATT control of master volume for E-volume (less than -15dB : L)	H
48				H
49	SYS_DT	O	Data signal for communication with M62446, TC9163, TC9164 and PLL	H
50	SYS_CK	O	Clock signal for communication with M62446, TC9163, TC9164 and PLL	H

• Pin Function

No.	Pin Name	I/O	Pin Function	Active
51	9273_CS	O	Chip select for TC9273	H
52	DSP_MT	O	DSP Mute (ASSY mute)	H
53	GAIN_SEL	O	Gain select (5.1ch and Stereo of analog input : H)	H
54	AMUTE	O	Audio mute	H
55	T_MUTE	O	Tuner mute	H
56	PLL_CE	O	Chip select for communication to LC72131 (Tuner)	
57	NECK_SEL	O	5.1ch, surround mode and A+B Stereo : H / Stereo : L	H
58	FM+(RDS)	O	Tr switch ON/OFF for power supply of RDS decoder (L : AM, power OFF , H : Other)	H
59	9164_CS	O	TC9163, TC9164 Chip select	
60	CRST	O	Reset for DSP	
61	CDC_PD	O	Power down for CODEC	
62	ABOT	O	Abort for DSP	H
63	RY_AC	O	AC relay ON/OFF	H
64	RY_A	O	Speaker A relay ON/OFF	H
65	RY_C/R	O	Rear/Center Speaker relay ON/OFF	H
66	EXP_CS	O	Chip select for expand IC	H
67	EXP OE	O	Chip select for expand IC	H
68	RY_AC	O	AC relay ON/OFF control	H
69	S22	O	Segment output 22	H
70	S21		Segment output 21	
71	S20		Segment output 20	
72	S19		Segment output 19	
73	S18		Segment output 18	
74	S17		Segment output 17	
75	S16		Segment output 16	
76	S15		Segment output 15	
77	S14		Segment output 14	
78	S13		Segment output 13	
79	S12		Segment output 12	
80	S11		Segment output 11	
81	S10		Segment output 10	
82	S9		Segment output 9	
83	S8		Segment output 8	
84	S7		Segment output 7	
85	S6		Segment output 6	
86	S5		Segment output 5	
87	S4		Segment output 4	
88	S3		Segment output 3	
89	VDD	-	5V	
90	S2	O	Segment output 2	H
91	S1		Segment output 1	
92	Not used	O	Not used (Fixed Vfdp)	
93	G10	O	Grid output 10	H
94	G9		Grid output 9	
95	G8		Grid output 8	
96	G7		Grid output 7	
97	G6		Grid output 6	
98	G5		Grid output 5	
99	G4		Grid output 4	
100	G3		Grid output 3	

■ AK4586VQ (DD&INPUT ASSY : IC9101)

• 96kHz 24Bit 6-channel CODEC with DIR

■ Pin Arrangement (Top View)

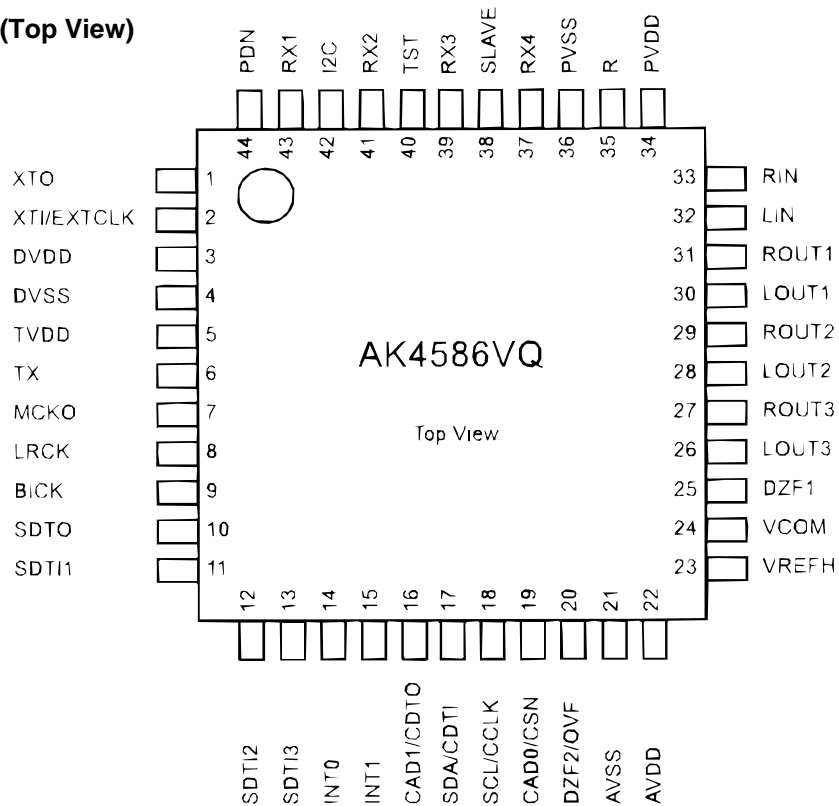

■ Block Diagram

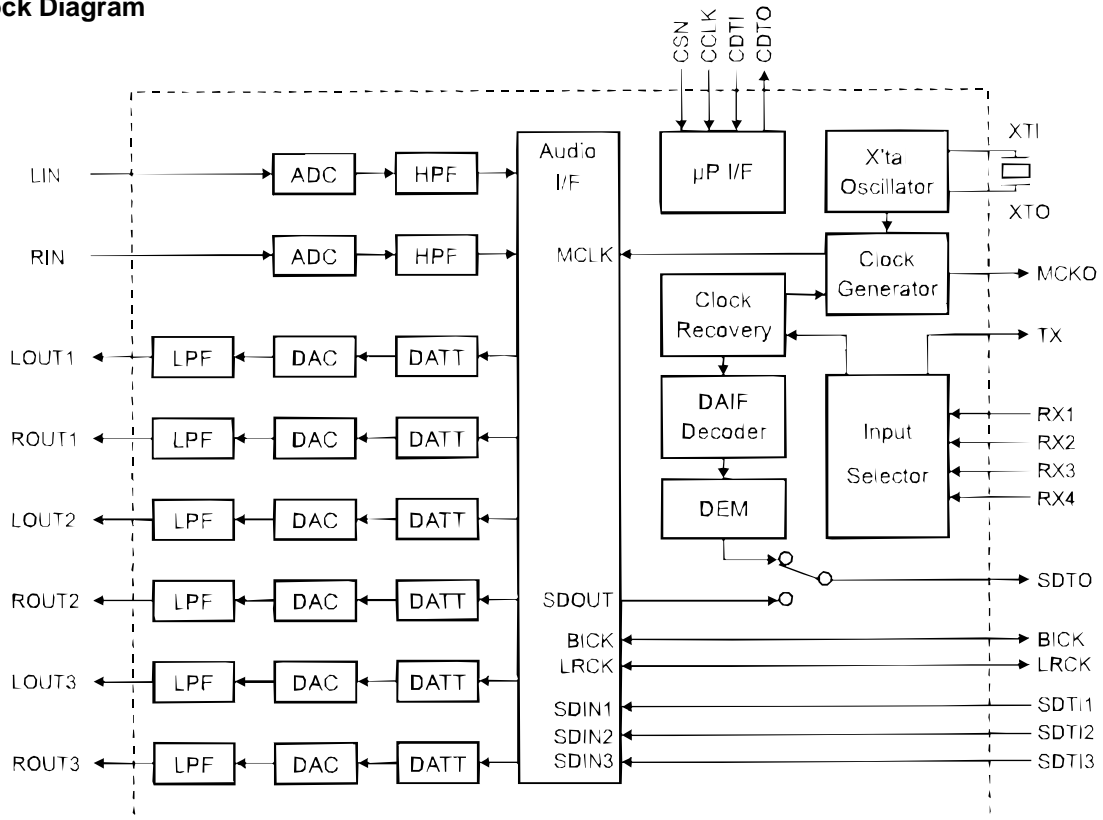

■ Pin / Function

PIN/FUNCTION			
No.	Pin Name	I/O	Function
1	XTO	O	X'tal Output Pin
2	XTI	I	X'tal Input Pin
	EXTCLK	I	External Master Clock Input Pin
3	TVDD	-	Output Buffer Power Supply Pin, 2.7V~5.5V
4	DVSS	-	Digital Ground Pin, 0V
5	DVDD	-	Digital Power Supply Pin, 4.5V~5.5V
6	TX	O	Transmit channel (through data) Output Pin
7	MCKO	O	Master Clock Output Pin
8	LRCK	I/O	Input/Output Channel Clock Pin
9	BICK	I/O	Audio Serial Data Clock Pin
10	SDTO	O	Audio Serial Data Output Pin
11	SDTI1	I	DAC1 Audio Serial Data Input Pin
12	SDTI2	I	DAC2 Audio Serial Data Input Pin
13	SDTI3	I	DAC3 Audio Serial Data Input Pin
14	INT0	O	Interrupt 0 pin
15	INT1	O	Interrupt 1 pin
16	CDTO	O	Control Data Output Pin in 4-wire serial control mode
	CAD1	I	Chip Address 1 Pin in I ² C bus control mode
17	CDTI	I	Control Data Input Pin in 4-wire serial control mode
	SDA	I/O	Control Data Input/Output Pin in I ² C bus control mode
18	CCLK	I	Control Data Clock Pin in 4-wire serial control mode
	SCL	I	Control Data Clock Pin in I ² C bus control mode
19	CSN	I	Chip Select Pin in 4-wire serial control mode
	CAD0	I	Chip Address 0 Pin in I ² C bus control mode
20	DZF2	O	Zero Input Detect 2 Pin (Note 1) When the input data of the group 1 follow total 8192 LRCK cycles with "0" input data, this pin goes to "H".
	OVF	O	Analog Input Overflow Detect Pin (Note 2) This pin goes to "H" if the analog input of Lch or Rch is overflows.
21	AVSS	-	Analog Ground Pin, 0V
22	AVDD	-	Analog Power Supply Pin, 4.5V~5.5V

■ Pin / Function

No.	Pin Name	I/O	Function
23	VREFH	I	Positive Voltage Reference Input Pin, AVDD
24	VCOM	O	Common Voltage Output Pin, AVDD/2 Large external capacitor around 2.2 μ F is used to reduce power-supply noise.
25	DZF1	O	Zero Input Detect 1 Pin (Note 1) When the input data of the group 1 follow total 8192 LRCK cycles with "0" input data, this pin goes to "H".
26	LOUT3	O	DAC3 Lch Analog Output Pin
27	ROUT3	O	DAC3 Rch Analog Output Pin
28	LOUT2	O	DAC2 Lch Analog Output Pin
29	ROUT2	O	DAC2 Rch Analog Output Pin
30	LOUT1	O	DAC1 Lch Analog Output Pin
31	ROUT1	O	DAC1 Rch Analog Output Pin
32	LIN	I	Lch Analog Input Pin
33	RIN	I	Rch Analog Input Pin
34	PVDD	-	PLL Power Supply Pin, 4.5V~5.5V
35	R	-	External Resistor Pin 18k Ω +/-1% resistor to PVSS externally.
36	PVSS	-	PLL Ground Pin, 0V
37	RX4	I	Receiver Channel 4 Pin (Internal biased pin)
38	SLAVE	I	Slave Mode Pin "L": Master mode or Slave mode, "H": Slave mode
39	RX3	I	Receiver Channel 3 Pin (Internal biased pin)
40	TST	I	Test Pin This pin should be connected to DVSS.
41	RX2	I	Receiver Channel 2 Pin (Internal biased pin)
42	I2C	I	Control Mode Select Pin "L": 4-wire Serial, "H": I ² C Bus
43	RX1	I	Receiver Channel 1 Pin (Internal biased pin)
44	PDN	I	Power-Down & Reset Pin When "L", the AK4586 is powered-down, all output pins go to "L" and the control registers are reset to default state. If the state of CAD1-0 changes, then the AK4586 must be reset by PDN.

Notes:

1. The group 1 and 2 can be selected by DZFM2-0 bits.
2. This pin becomes OVF pin if OVFE bit is set to "1".
3. All input pins except internal biased pins should not be left floating.

■ NJU7312AM (D.D & INPUT ASSY : IC102)

• Analog Switch Array

• Block Diagram

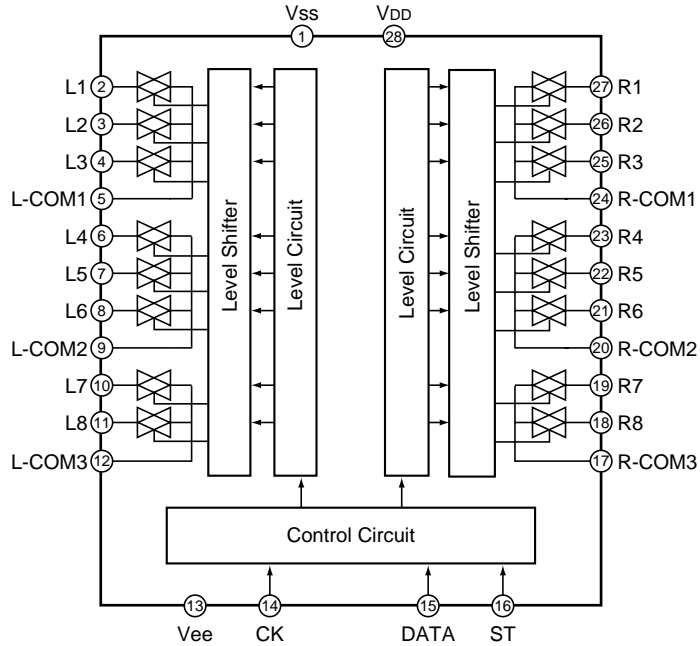

• Pin Function

No.	Pin Name	Function
1	VSS	Minus Power Supply
2, 27	L1,R1	Input and Output
3, 26	L2,R2	
4, 25	L3,R3	
5, 24	COM1	
6, 23	L4,R4	
7, 22	L5,R5	
8, 21	L6,R6	
9, 20	COM2	
10, 19	L7,R7	
21, 18	L8,R8	
26, 17	COM3	
13	GND	Digital Ground
14	CK	Clock Input
15	DATA	Data Input
16	ST	Strobe Input
28	VDD	Plus Power Supply

■ PD8097A (D.D & INPUT ASSY : IC9504)

- 4Mb P2ROM

■ Pin Arrangement (Top View)

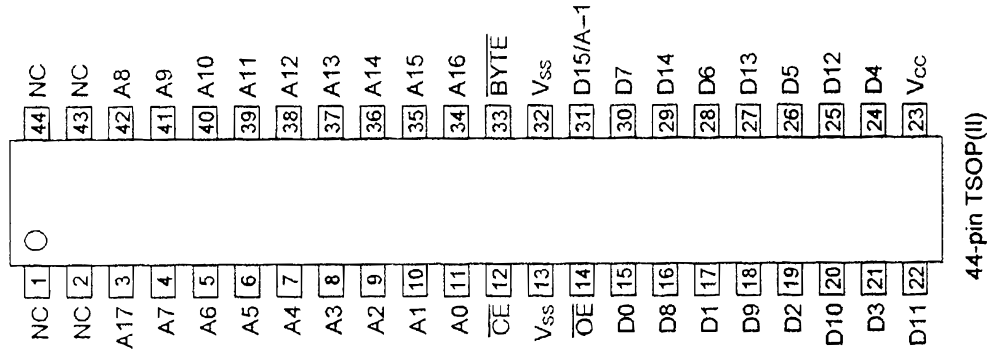

■ Block Diagram

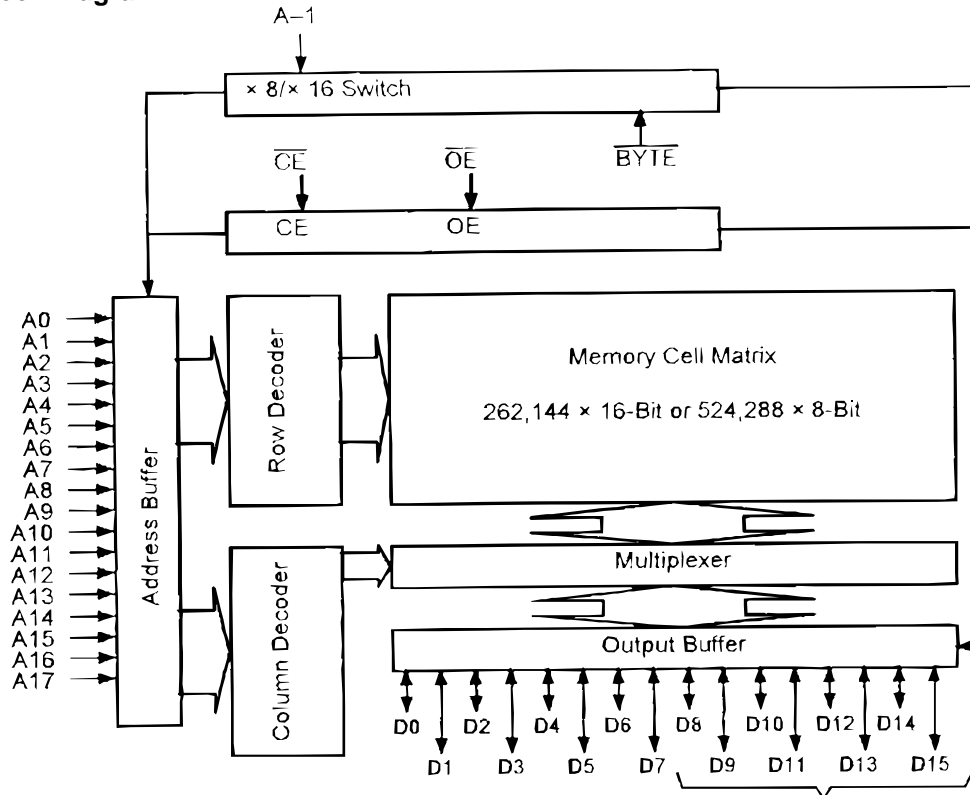

In 8-bit output mode, these pins are placed in a high-Z state and pin D15 functions as the A-1 address pin.

7.2.2 DISPLAY

■ XAV3013 (FRONT ASSY : V401)

- FL DISPLAY

- Pin Assignment

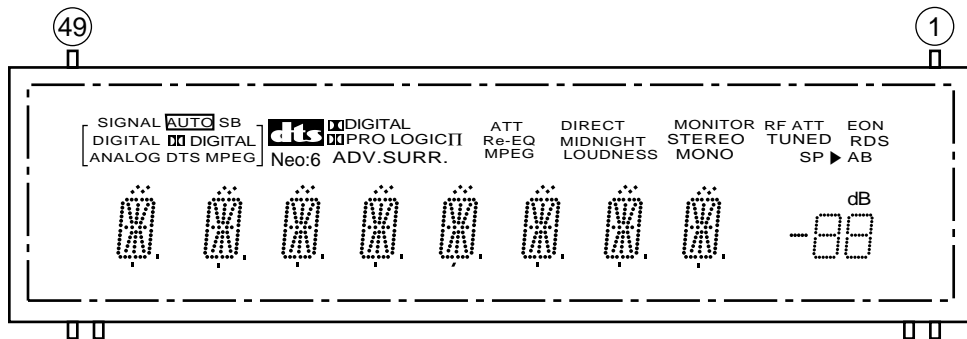

- Grid Assignment

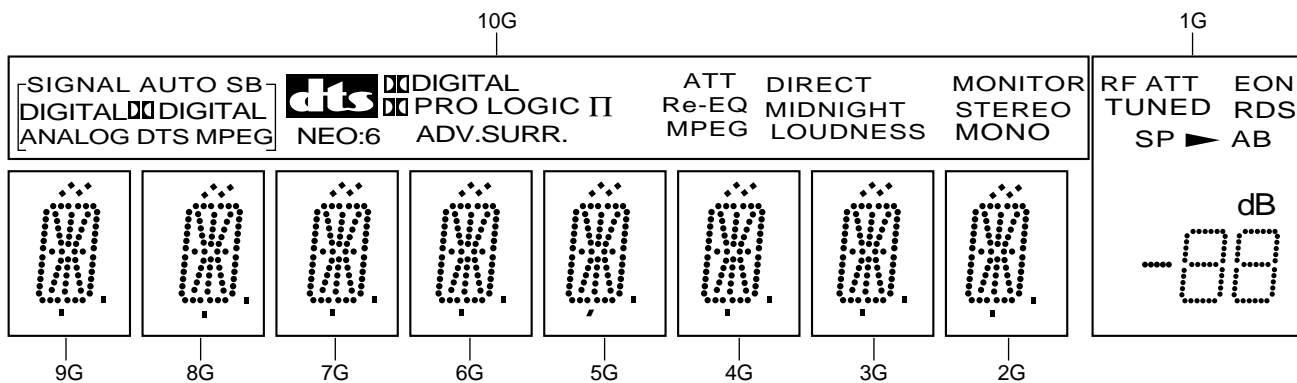

- Segment Designation

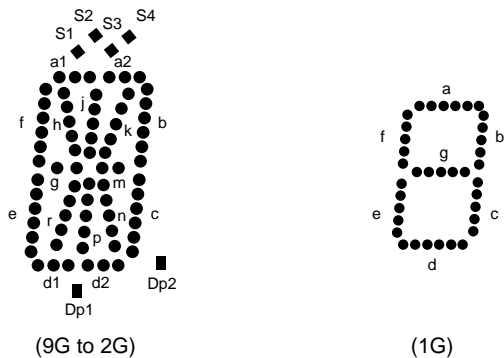

VSX-D711-K, VSX-D711-S

• Pin Connection

Pin No.	49	48	47	46	45	44	43	42	41	40	39	38	37	36	35	34	33	32	31	30	29	28	27	26	25
Connection	F2	F2	NP	NP	P22	P21	P20	P19	P18	P17	P16	P15	P14	P13	P12	P11	P10	P9	P8	P7	P6	P5	P4	P3	P2
Pin No.	24	23	22	21	20	19	18	17	16	15	14	13	12	11	10	9	8	7	6	5	4	3	2	1	
Connection	P1	NX	NX	NX	NX	NX	NX	NX	NX	NX	10G	9G	8G	7G	6G	5G	4G	3G	2G	1G	NP	NP	F1	F1	

NOTE 1) F1, F2..... Filament
 2) NP..... No pin
 3) NX..... No extend pin
 4) DL..... Datum Line
 5) 1G to 10G..... Grid
 6) Field of vision is a minimum of 21.8° from the lower side.

• Anode Connection

	10G	9G	8G	7G	6G	5G	4G	3G	2G	1G
P1	S1	a1	a1	a1	a1	a1	a1	a1	a1	RFATT
P2	AUTO	a2	a2	a2	a2	a2	a2	a2	a2	EON
P3	SB	h	h	h	h	h	h	h	h	○
P4	DIGITAL	j	j	j	j	j	j	j	j	TUNED
P5	ANALOG	k	k	k	k	k	k	k	k	RDS
P6	DIGITAL (L)	b	b	b	b	b	b	b	b	S1
P7	DTS	f	f	f	f	f	f	f	f	A
P8	MPEG	m	m	m	m	m	m	m	m	B
P9	DTS	g	g	g	g	g	g	g	g	1a
P10	MPEG	c	c	c	c	c	c	c	c	1b
P11	DIGITAL (R)	e	e	e	e	e	e	e	e	1f
P12	PROLOGIC II	r	r	r	r	r	r	r	r	1g
P13	Neo:6	p	p	p	p	p	p	p	p	1c
P14	ATT	n	n	n	n	n	n	n	n	1e
P15	ADV.SURR.	d1	d1	d1	d1	d1	d1	d1	d1	1d
P16	Re-EQ	d2	d2	d2	d2	d2	d2	d2	d2	2a
P17	DIRECT	Dp2	Dp2	Dp2	Dp2	Dp2	Dp2	Dp2	Dp2	2b
P18	MIDNIGHT	Dp1	Dp1	Dp1	Dp1	Dp1	Dp1	Dp1	Dp1	2f
P19	LOUDNESS	S1	S1	S1	S1	S1	S1	S1	S1	2g
P20	MONITOR	S4	S4	S4	S4	S4	S4	S4	S4	2c
P21	STEREO	S2	S2	S2	S2	S2	S2	S2	S2	2e
P22	MONO	S3	S3	S3	S3	S3	S3	S3	S3	2d

7.3 CLEANING



Before shipping out the product, be sure to clean the following positions by using the prescribed cleaning tools:

Position to be cleaned	Cleaning tools
Fan	Cleaning paper : GED-008

8. PANEL FACILITIES

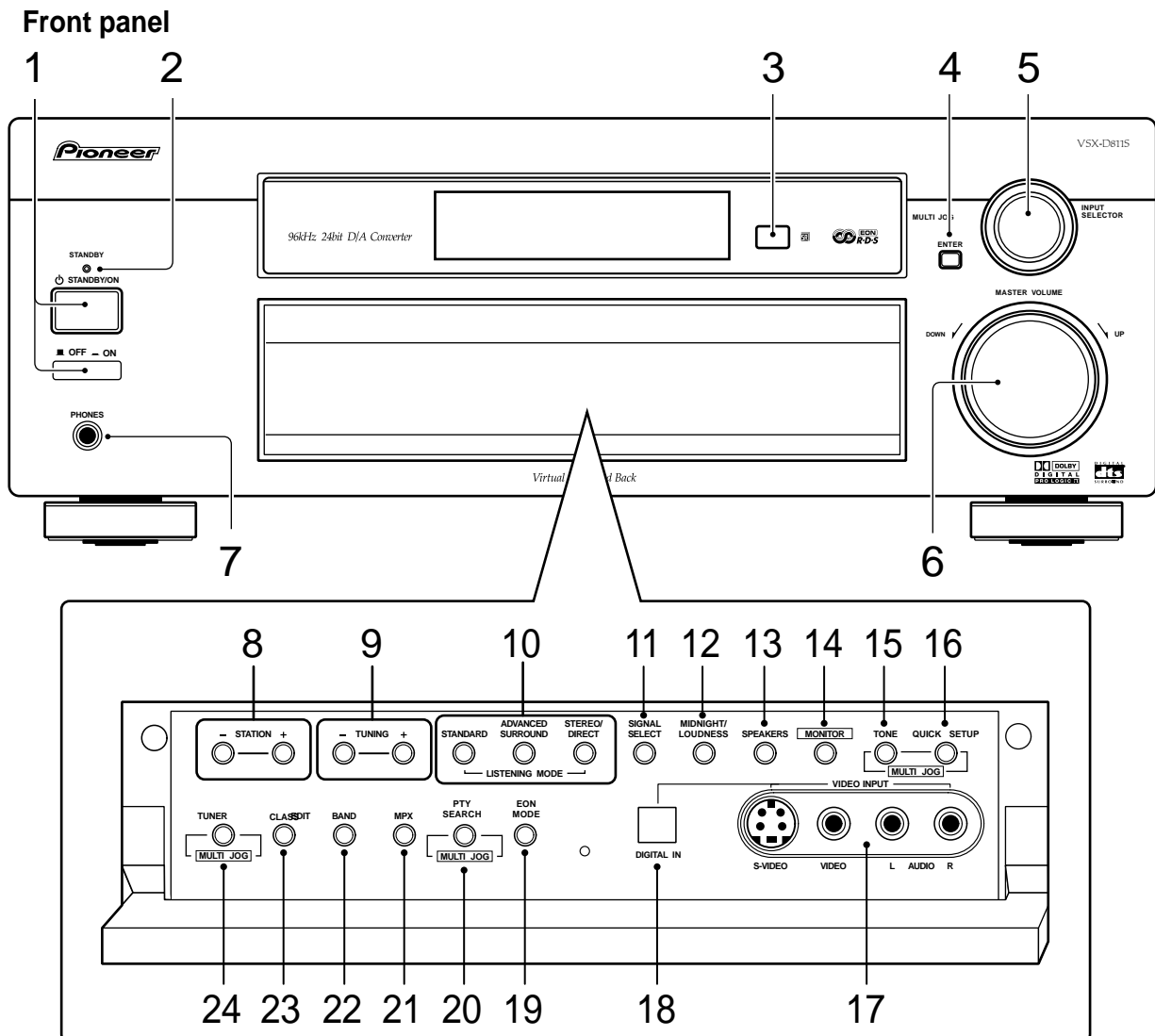

1 STANDBY/ON-power OFF ON button
STANDBY/ON switches the receiver between on and standby. The power button switches the receiver off.

2 STANDBY indicator
Lights when the receiver is in standby.

3 Remote sensor
Receives the signals from the remote control.

4 ENTER

5 MULTI JOG/INPUT SELECTOR dial
The MULTI JOG/INPUT SELECTOR dial performs a number of tasks. Use it to select options after pressing TONE CONTROL, QUICK SETUP, TUNER EDIT or PTY SEARCH.

6 MASTER VOLUME

7 PHONES jack
Use to connect headphones. When the headphones are connected, there is no sound output from the speakers.

8 STATION (+/-) buttons
Selects station presets when using the tuner.

9 TUNING buttons
Selects the frequency when using the tuner.

10 LISTENING MODE buttons

STANDARD

Press for Standard decoding and to switch between the various Pro Logic II options.

ADVANCED SURROUND

Use to switch between the various surround modes.

STEREO/DIRECT

Switches direct playback on or off. Direct playback bypasses the tone controls and channel levels for the most accurate reproduction of a source.

VSX-D711-K, VSX-D711-S

11 SIGNAL SELECT

Use to select between input signals.

12 MIDNIGHT/LOUDNESS

Use Midnight when listening to movie soundtracks at low volume.
Use Loudness to boost the bass and treble at low volume.

13 SPEAKERS

Use to cycle through the speaker system: A → B → A+B

14 MONITOR

Press to switch tape monitoring on/off.

15 TONE

Press this button to access the bass and treble controls, which you can then adjust with the MULTI JOG/INPUT SELECTOR dial.

16 QUICK SETUP

17 VIDEO INPUT

18 DIGITAL IN (VSX-D811S only)

19 EON MODE

Use to search for different programs that are transmitting traffic or news information (this search method is called EON).

20 PTY SEARCH

Use to search for different program types in RDS mode.

21 MPX

Press to receive a radio broadcast in mono.

22 BAND

Switches between AM and FM radio bands.

23 CLASS

Switches between the three banks (classes) of station presets.

24 TUNER EDIT

Use for memorizing and naming stations.

Rear Panel

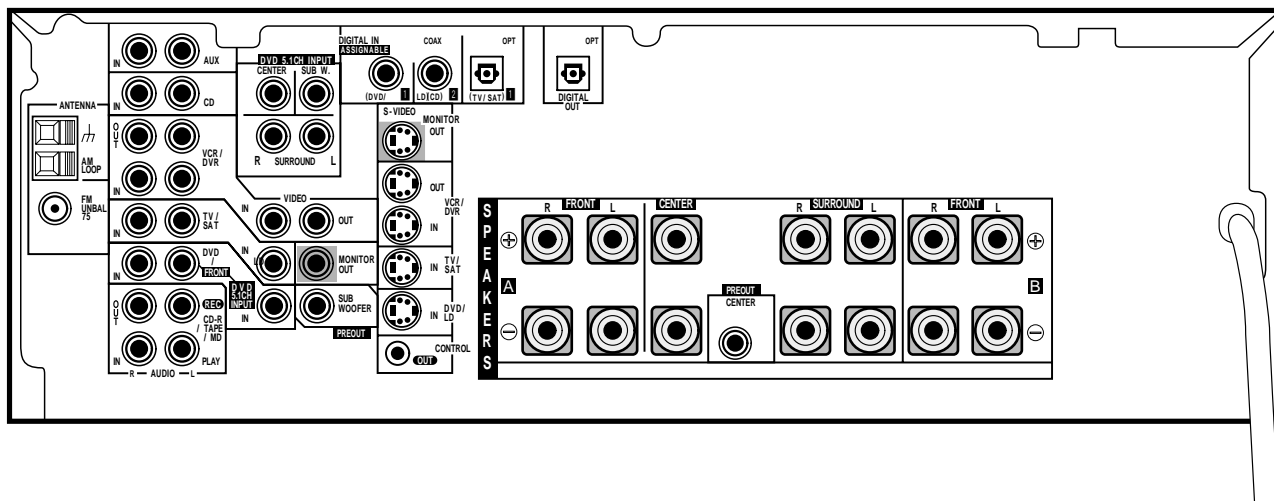

Display

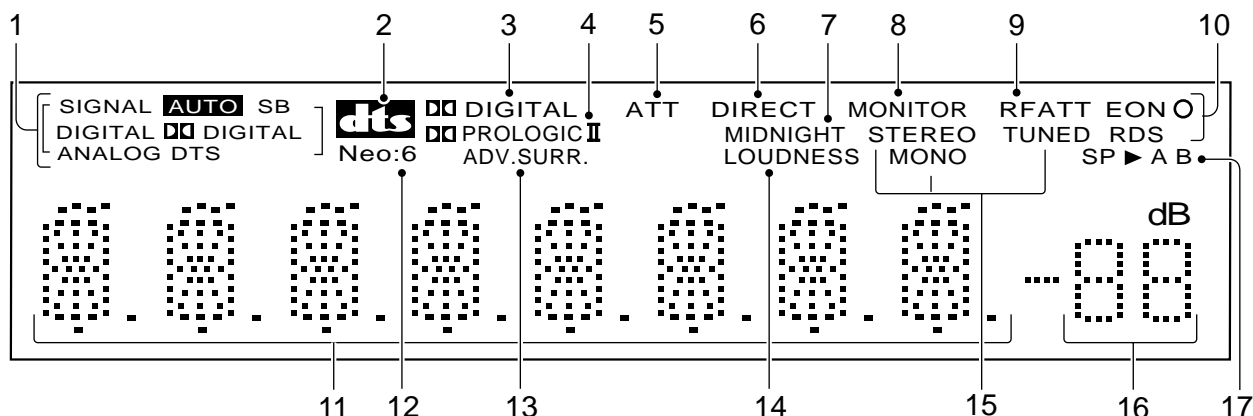

1 SIGNAL SELECT indicators

Lights to indicate the type of input signal assigned for the current component:

AUTO

Lights when AUTO signal select is on

SB (VSX-D811S only)

Depending on the source, this lights when a signal with surround back channel encoding is detected.

DIGITAL

Lights when a digital audio signal is detected.

■ DIGITAL

Lights when a Dolby Digital encoded signal is detected.

ANALOG

Lights when an analog signal is detected.

DTS

Lights when a source with DTS encoded audio signals is detected.

2 DTS

When the Standard mode of the receiver is on, this lights to indicate decoding of a DTS signal.

3 ■ DIGITAL

When the Standard mode of the receiver is on, this lights to indicate decoding of a Dolby Digital signal.

4 ■ PRO LOGIC II

When the Standard mode of the receiver is on, this lights to indicate Pro Logic II decoding.

5 ATT

Lights when INPUT ATT is used to attenuate (reduce) the level of the analog input signal.

6 DIRECT

Lights when source direct playback is in use. This function bypasses all tone, balance, Advanced Surround, and Dolby Surround effects.

7 MIDNIGHT

Lights during Midnight listening.

8 MONITOR

Lights when MONITOR is selected.

9 RF ATT

Lights when the RF ATT is on.

10 EON and O

The O indicator lights to inform you that the currently tuned station carries the EON data service. When the EON mode is set, the EON indicator lights, but during actual reception of an EON broadcast the EON indicator will flash.

RDS

Lights when an RDS broadcast is received.

11 Character display

12 Neo:6 (VSX-D811S only)
Lights during NEO:6 processing

13 ADV. SURR (Advanced Surround)

Lights when one of the Advanced Surround modes has been selected.

14 LOUDNESS

Lights when LOUDNESS has been selected.

15 TUNER indicators

STEREO:

Lights when a stereo FM broadcast is being received in auto stereo mode.

MONO:

Lights when the mono mode is set using the MPX button.

TUNED:

Lights when a broadcast is being received.

16 Master volume level

Shows the overall volume level. ---dB indicates the minimum level, and -0 dB indicates the maximum level.

Depending on your level settings for each channel, the maximum level can range between -10 dB and -0 dB.

17 Speaker indicator

Shows the speaker system currently in use.

Remote control

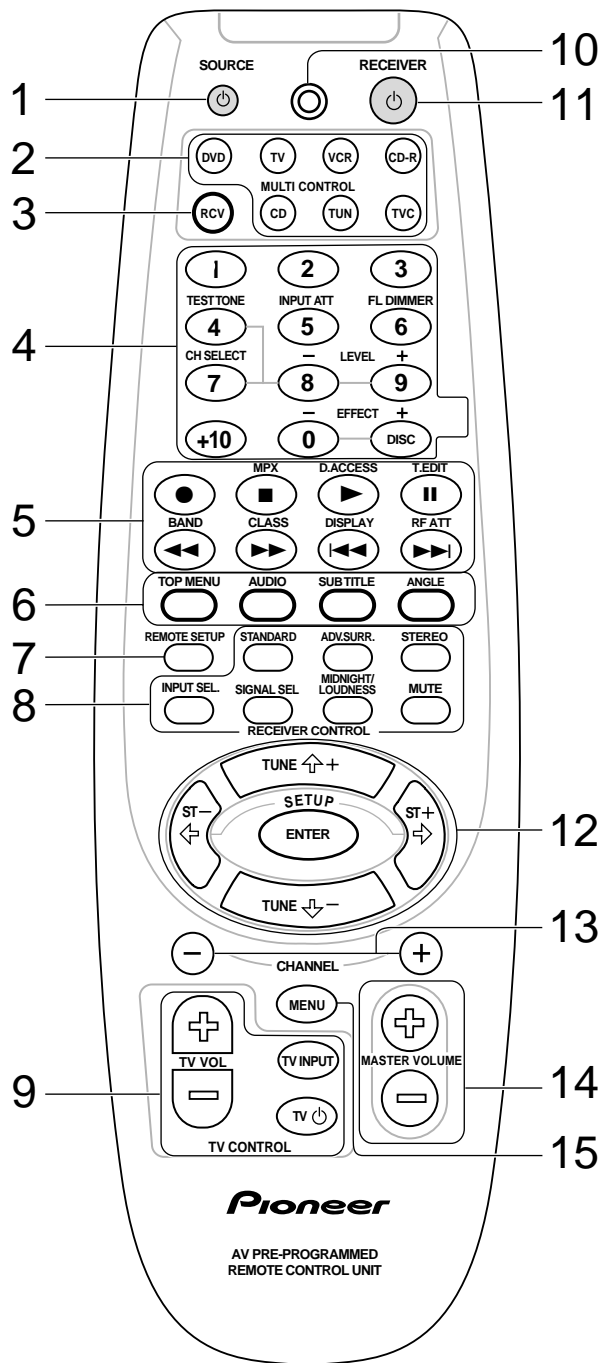

1 SOURCE

Press to turn on/off other components connected to the receiver.

2 MULTI CONTROL buttons

Press to select control of other components (see Controlling the rest of your system).

3 RCV

Use to switch to the receiver controls on the remote control (ex. INPUT ATT, FL. DIMMER). Also use this button to set up surround sound.

4 Number buttons/Receiver controls

Use the number buttons to directly select a radio frequency or the tracks on a CD, DVD, etc.

DISC

The button's use depends on the component selected.

Receiver Controls

Press the RCV button first to access the functions above the number buttons. The display flashes when it isn't possible to use a function.

TEST TONE

Sounds the test tone when setting up the surround sound of the receiver.

INPUT ATT

Attenuates (lowers) the level of an analog input signal to prevent distortion.

FL DIMMER

Dims or brightens the display.

CH SELECT

Selects a speaker when setting up the surround sound of the receiver.

LEVEL +/-

Adjusts the levels of the surround sound of the receiver.

EFFECT +/- buttons

Adds or subtracts the amount of effect with different advanced listening modes (except 5 or 6 Ch Stereo and Virtual SB).

5 Component/Tuner controls

The main buttons (▶, ■, etc.) are used to control a component after you have selected it using the MULTI CONTROL buttons. The tuner/DTV controls above these buttons can be accessed after you have selected the corresponding MULTI CONTROL button (TUNER or DVD (when connected to DTV)).

MPX

Switches between stereo and mono reception of FM broadcasts. If the signal is weak then switching to mono will improve the sound quality. Also acts as a stop button for CDs, tapes, or DVDs.

D. ACCESS

After pressing, you can access a radio station directly using the number buttons.

T. EDIT

Use for memorizing and naming stations.

BAND

Switches between the tuner AM and FM bands.

CLASS

Switches between the three banks (classes) of radio station presets.

DISPLAY

Use to switch the display between tuner displays (including RDS information).

RF ATT

Use to lower the input level of a radio signal that is too powerful or contains interference that causes the sound to distort.

6 DVD controls (Press DVD first to access)

These controls will also function as DTV controls, depending on the component you've selected.

TOP MENU

Displays the disc 'top' menu of a DVD.

AUDIO

Changes the audio language or channel.

SUBTITLE

Displays/changes the subtitles included in multilingual DVD-Video discs.

ANGLE

Switches camera angles on discs with multi-angle scenes.

7 REMOTE SETUP

Press this button to set up the remote control to control other components.

8 RECEIVER CONTROL buttons

STANDARD

Press to switch between the various Dolby/DTS modes.

ADV. SURR.

Use to switch between the various surround modes.

STEREO

Switches direct playback on or off. Direct playback bypasses the tone controls and channel levels for the most accurate reproduction of a source.

INPUT SEL

Use to select the input source.

SIGNAL SEL

Use to select between input signals.

MIDNIGHT/LOUDNESS

Switches to Midnight or Loudness listening.

MUTE

Mutes the sound (or restores the sound if it has been muted).

9 TV control buttons

These buttons are dedicated to control the TV assigned to the TVC button. Thus if you only have one TV to hook up to this system assign it to the TVC MULTI CONTROL button. If you have two TVs, assign the main TV to the TVC button.

TV VOL +/-

Use to adjust the volume on your TV.

TV INPUT

Use select the TV function.

TV ⏻

Use to turn on/off the power of the TV.

10 LED DISPLAY

This display flashes when a command is sent from the remote control.

11 RECEIVER ⏻

This switches between standby and on for this receiver.

12 ⏪ ⏩ ⏴ ⏵ (TUNE/ST +/-) /ENTER

Use the arrow buttons when setting up your surround sound system (see pages 65–76). Also used to control DVD menus/options and for deck 1 of a double cassette deck player. Use the TUNE +/- buttons to find radio frequencies and use ST +/- to find preset stations.

13 CHANNEL +/-

Select radio station presets. Also skip tracks backward or forward on CDs, DVDs, etc.

14 MASTER VOLUME +/-

Use to set the listening volume.

15 MENU button

Displays the disc menu of DVD-Video discs. It also displays TV and DTV menus.