

Helping Customers Innovate, Improve & Grow



## Description

Vectron's VT-701 Temperature Compensated Crystal Oscillator (TCXO) is a quartz stabilized, clipped sine wave output, analog temperature compensated oscillator, operating off either a 3.3 or 5.0 volt supply in a hermetically sealed 5x7 ceramic package.

## Features

- CMOS Output
- Output Frequencies to 27 MHz
- Fundamental Crystal Design
- Optional VCXO Function available
- Gold over nickel contact pads
- Hermetically Sealed Ceramic SMD package
- Product is compliant to RoHS directive  and fully compatible with lead free assembly

## Applications

- FPGA's
- A/D's, D/A's
- Broadband Access Head End
- Wireless Communications
- Base Stations
- Point to point radios
- Broadband Access
- Test Equipment

## Block Diagram

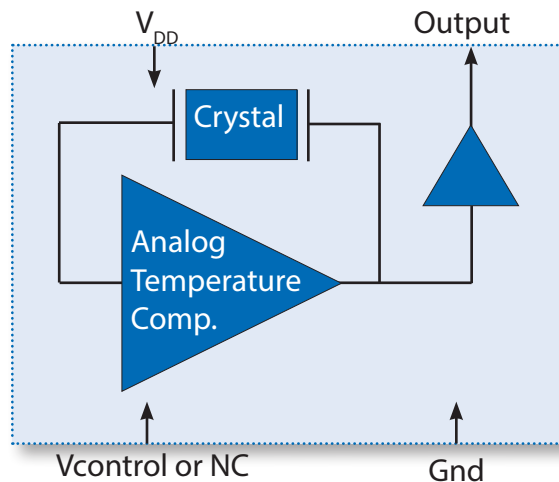
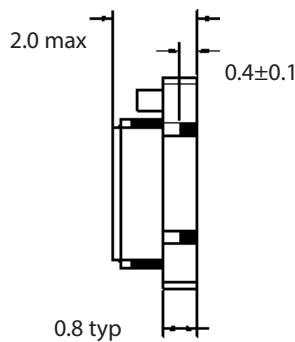
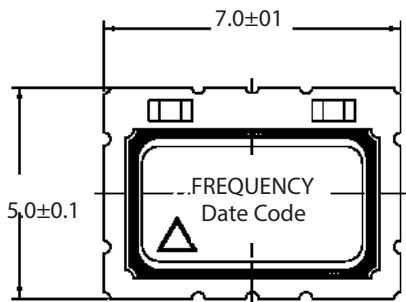

**Table 1. Electrical Performance**

Parameter	Symbol	Min.	Typ	Max	Units
Output Frequency	$f_o$	5		27	MHz
Supply Voltage <sup>1</sup> , <i>Ordering Option</i>	$V_{DD}$	+3.3 or +5.0			Vdc
Supply Current	$I_{DD}$			10	mA
Operating Temperature, <i>Ordering Option</i>	$T_{OP}$	0/55, -10/60, -20/70, -30/80, -40/85			°C
Stability Over $T_{OP}$ , <i>Ordering Option</i>		$\pm 0.5, \pm 1.0, \pm 1.5, \pm 2.0, \pm 2.5, \pm 3.0, \pm 4.0, \pm 5.0$			ppm
Initial Accuracy, "No Adjust" Option				$\pm 1.0$	ppm
Power Supply Stability				$\pm 0.3$	ppm
Load Stability				$\pm 0.2$	ppm
Aging				$\pm 1.0$	ppm/yr
Pull Range, <i>ordering option</i>	TPR	$\pm 5, \pm 8, \pm 10, \pm 12$			ppm
Control Voltage to reach Pull Range		0.5		2.5	V
Control Voltage Impedance		1			Mohm
Output Level <sup>2</sup>					
Output Logic High	$V_{OH}$	$0.8 * V_{DD}$			V
Output Logic Low	$V_{OL}$			$0.1 * V_{DD}$	V
Output Logic High Drive	$I_{OH}$			-4	mA
Output Logic Low Drive	$I_{OL}$	4			mA
Output Load				15	pF
Phase Noise, 10.000MHz					dBc/Hz
10Hz			-92		
100Hz			-116		
1kHz			-137		
10kHz			-149		
100kHz			-154		
Enable Disable <sup>3</sup> , Output Enabled	$V_{IH}$	$0.3 * V_{DD}$		$0.7 * V_{DD}$	
Output Disabled	$V_{IL}$				
Start Up Time				2	ms

1. The V-701 power supply pin should be filtered, eg, a 0.1 and 0.01 uf capacitor
2. The Output is DC coupled
3. Output is Enabled if E/D is left open

**Outline Drawing**



**Recommended Pad Layout**

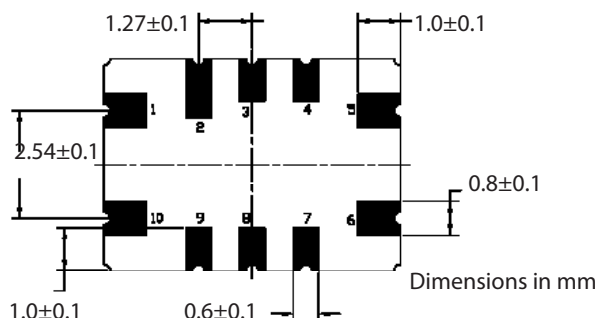
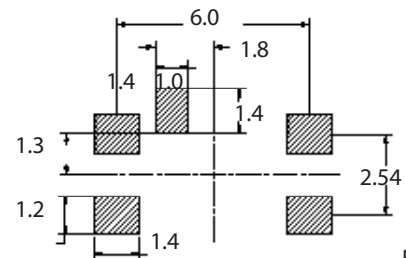

**Table 2. Pinout**

Pin #	Symbol	Function
1	$V_C$	TCXO Control Voltage or Ground
2,3,4	NC	Make No Connection
5	GND	Electrical and Lid Ground
6	$f_o$	Output Frequency
7,8	NC	Make No Connection
9	E/D	Enable Disable
10	$V_{DD}$	Supply Voltage

## Test Circuit

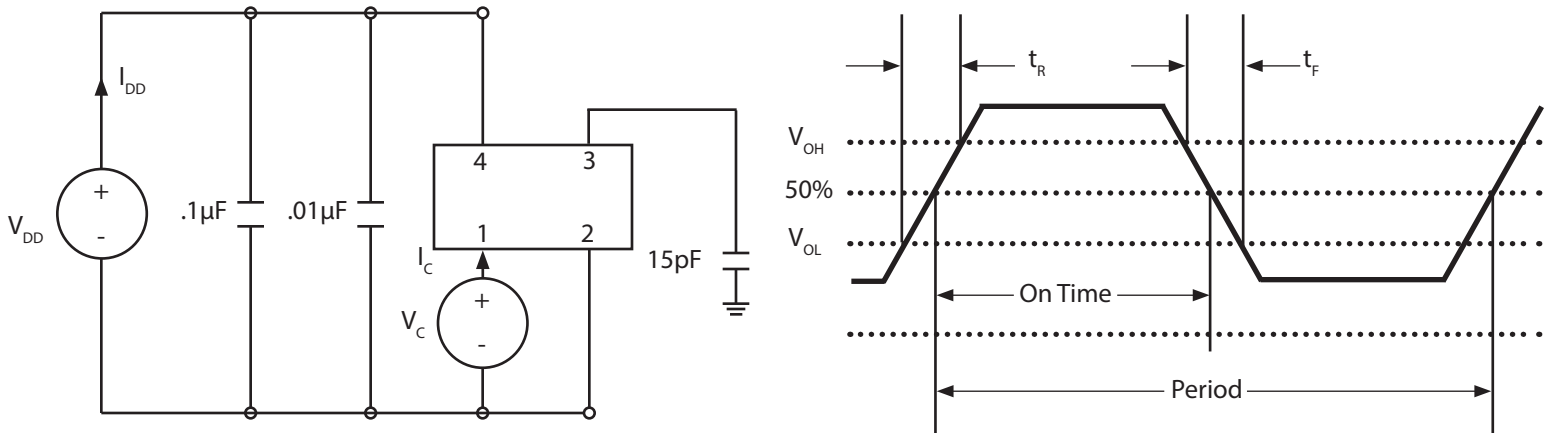

## VCXO Function

**VCXO Feature:** The VT-701 can be ordered with a VCXO function for applications where it will be used in a PLL, or the output frequency needs fine tune or calibration adjustments. This is a high impedance input, 1Mohm, and can be driven with an op-amp or terminated with adjustable resistors etc. **Pin 1 should not be left floating on the VCXO optional device.**

**“No Adjust” Option:** In applications where the VT-701 will not be used in a PLL, or the output frequency does not need fine tune adjustments, the best device to use would be a VT-701-xxx-xxx0. By using the “no adjust” option, the circuit is simplified as  $V_C$  does not need to be adjusted or set to a predetermined voltage and pin 1 should be grounded (pin 1 can be left open but should not be set to a voltage such as an RF signal or power supply voltage).

## Maximum Ratings

### Absolute Maximum Ratings and Handling Precautions

Stresses in excess of the absolute maximum ratings can permanently damage the device. Functional operation is not implied or any other excess of conditions represented in the operational sections of this data sheet. Exposure to absolute maximum ratings for extended periods may adversely affect device reliability.

Although ESD protection circuitry has been designed into the VT-701, proper precautions should be taken when handling and mounting, VI employs a Human Body Model and Charged Device Model for ESD susceptibility testing and design evaluation.

ESD thresholds are dependent on the circuit parameters used to define the model. Although no industry standard has been adopted for the CDM a standard resistance of 1.5kOhms and capacitance of 100pF is widely used and therefore can be used for comparison purposes.

**Table 3. Maximum Ratings**

Parameter	Symbol	Rating	Unit
Storage Temperature	$T_{STORE}$	-55/125	°C
Supply Voltage	$V_{DD}$	6	V
Control Voltage	$V_C$	0/ $V_{DD}$	V
ESD, Human Body Model		1500	V
ESD, Charged Device Model		1000	V

**Table 4. Environmental Compliance**

Parameter	Condition
Mechanical Shock	MIL-STD-883 Method 2002
Mechanical Vibration	MIL-STD-883 Method 2007
Temperature Cycle	MIL-STD-883 Method 1010
Solderability	MIL-STD-883 Method 2003
Fine and Gross Leak	MIL-STD-883 Method 1014
Resistance to Solvents	MIL-STD-883 Method 2015
Moisture Sensitivity Level	MSL1
Contact Pads	Gold over Nickel

# IR Compliance

## Suggested IR Profile

Devices are built using lead free epoxy and can be subjected to standard lead free IR reflow conditions shown in Table 5. Contact pads are gold over nickel and lower maximum temperatures can also be used, such as 220C.

Parameter	Symbol	Value
PreHeat Time	$t_s$	200 sec Max
Ramp Up	$R_{UP}$	3°C/sec Max
Time above 217°C	$t_L$	150 sec Max
Time to Peak Temperature	$t_{AMB-P}$	480 sec Max
Time at 260°C	$t_P$	30 sec Max
Time at 240°C	$t_{P2}$	60 sec Max
Ramp down	$R_{DN}$	6°C/sec Max

Solderprofile:

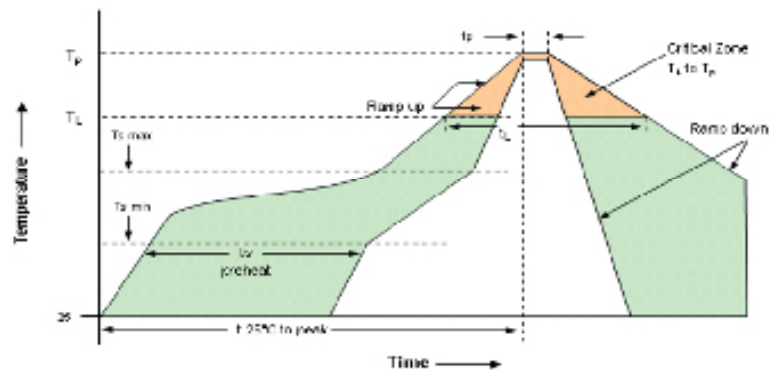

# Tape & Reel

Table 6. Tape and Reel Information

Tape Dimensions (mm)					Reel Dimensions (mm)							
W	F	Do	Po	P1	A	B	C	D	N	W1	W2	#/Reel
16	7.5	1.5	4	8	180	1.5	13	20.2	60	16.4	20.4	1000

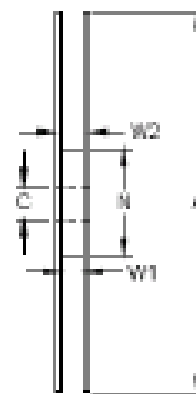
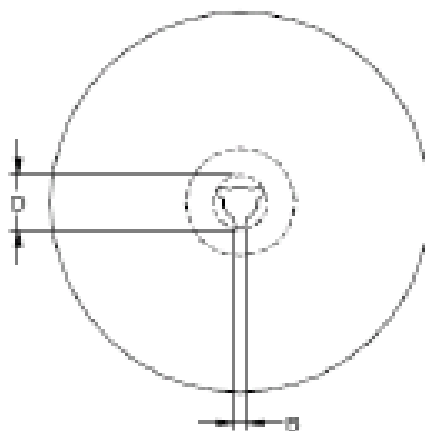
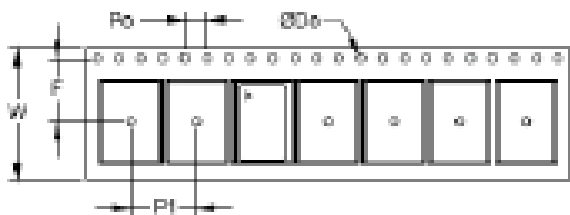

**Table 7. Standard Frequencies (MHz)**

**Standard Frequencies**

5.000*	6.400*	8.192	10.000	12.500*	12.800	13.000*	16.384	19.200	20.000
19.440	19.800	20.000	24.000	25.000	26.000	27.000			

**Ordering Information**

**VT-701- E A G - X X X A- xxMxxxxxxx**

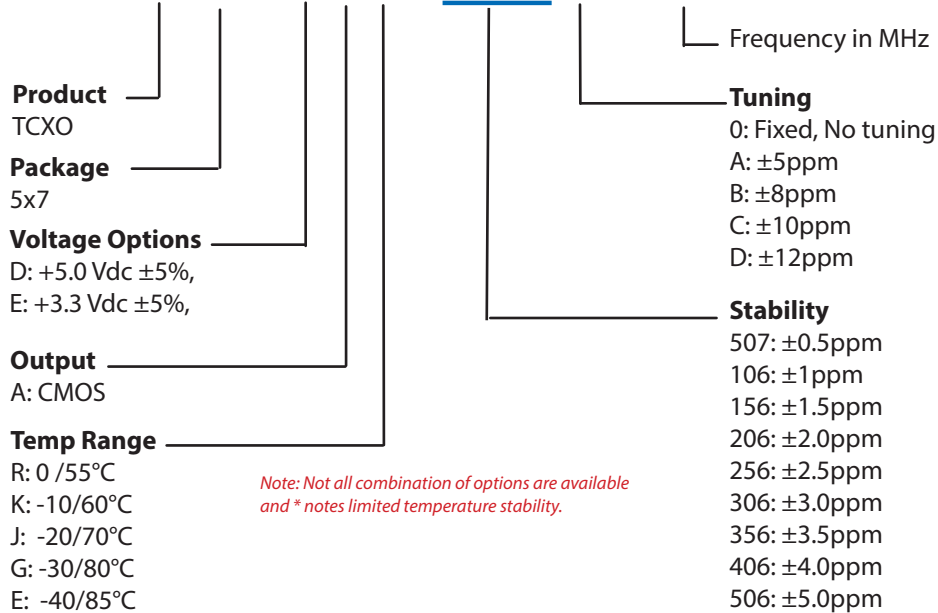

**Example: VT-701-EAG-206A-19M2000000**

**For Additional Information, Please Contact**

**USA:**

Vectron International  
267 Lowell Road, Suite 102  
Hudson, NH 03051  
Tel: 1.888.328.7661  
Fax: 1.888.329.8328

**Europe:**

Vectron International  
Landstrasse, D-74924  
Neckarbischofsheim, Germany  
Tel: +49 (0) 3328.4784.17  
Fax: +49 (0) 3328.4784.30

**Asia:**

Vectron International  
68 Yin Cheng Road (C), 22<sup>nd</sup> Floor  
One LuJiaZui  
Pudong, Shanghai 200120, China  
Tel: +86.21.6194.6886  
Fax: +86.21.6194.6699

**Disclaimer**

Vectron International reserves the right to make changes to the product(s) and or information contained herein without notice. No liability is assumed as a result of their use or application. No rights under any patent accompany the sale of any such product(s) or information.

Rev: 01/17/2017