



Single-chip optical mouse sensor for wireless applications

Data Brief

Features

- One chip solution with internal micro and minimal external circuitry
- 1.8V (single battery) or 2.0 V to 3.2 V (serial batteries) supply operation
- Very low power operation, enabling long battery life
- 800 / 1600 cpi resolution (switchable by simultaneous button press)
- Up to 10,000 frames per second
- Tracking at up to 40 ips
- Internal 27.045MHz modulator, frequency & deviation customizable via E2
- Single 12MHz Crystal design
- ST 4.8 kbps protocol, customization available via E2
- 254 ID codes
- Mechanical Z-wheel + 5 buttons
- Low battery detect and indicator
- Proven, high volume package technology, smallest package currently available on market
- Suitable for use with LED and laser light sources

Description

The VT5365 is the first generally available complete system on-chip for use in wireless optical mice. The device has been designed to provide long battery life whilst enabling excellent navigation control and precision on a wide range of surfaces. Housed in the smallest, currently available, package (7mm x 7mm), the chip is suitable for use in small form-factor mice demanded by laptop users. Minimal external circuitry is required thereby reducing BOM and assembly costs.

Applications

- Wireless optical mouse for Laptop/Desktop PC

Technical specifications

Resolution	800 (default) / 1600 CPI
Pixel size	30.4 μ m
Array size	20*20 pixels
Frame rate	Up to 10,000 frames/second
High speed motion detector ⁽¹⁾	400CPI - 32ips 800CPI - 16ips 1600CPI - 8ips 3200CPI - 4ips
Clock	12MHz
Supply voltage	1.8V
Supply current ⁽²⁾	Fast run (10Kfps) - 22mA Slow run (2.5Kfps) - 12mA Idle 1 - 500 μ A Idle 2 - 120 μ A Sleep - 70 μ A
Operating temperature	[0: 60] °C
Package type	7*7mm 32 lead LOQFP (Low profile Optical Quad Flat Pack)

1. Speed limitation is due to RF protocol, which is also in line with the USB Low Speed Device. The VT5365 motion detector can handle up to 40ips.

2. All currents were measured on an ST Reference Design Mouse supplied with 1.8V at maximum exposure and include LED and RF stage.

Order codes

Part number	Description
VT5365V032	Optical mouse sensor

Description (continued)

The VT5365 has been optimized for low power operation enabling long battery life, achieved by either a single 1.8V or 2.0 V to 3.2 V supply.

The on-chip regulators allow for a wide range of power supply taken from 2 batteries in series, enabling a low cost BOM. However, for the most efficient power consumption, the regulators can be bypassed so that the chip is driven at the minimal supply of 1.8V by an external power source (typically a DC/DC convertor from a single cell voltage). In both cases, an on-chip DCDC regulator controls the LED, so that only a single 1.8V supply is required for the overall application. The supply scheme is selected by connecting an IO to GND or VDD.

Care has been taken to implement ultra-low power idle/sleep modes with wake-ups at programmable periods and/or external events enabling very long battery life. It is estimated that with a typical user and 2 x AA Alkaline batteries configured in parallel a useful battery lifetime of 9 months can be achieved.

STMicroelectronics default firmware supports 5 buttons, mechanical Z-Wheel, low battery level detect/indicate output and internal DC/DC controller to supply the navigation LED.

The firmware generates baseband 4.8kbps, Manchester coded data with RF on signal for standby.

The output can be selected as either baseband RF serial data, or 27.045MHz FSK digitally modulated signal. In this case, very minimal external circuitry is required for filtering and amplification, and the overall system can be achieved using a single 12MHz Xtal.

This firmware may be replaced allowing customers to build in their own features for their particular mouse (including 2 extra GPIO).

The VT5365 sensor will operate over a wide range of illuminant wavelengths and is suitable for use with visible, IR and laser light sources.

Figure 1. VT5365 block diagram

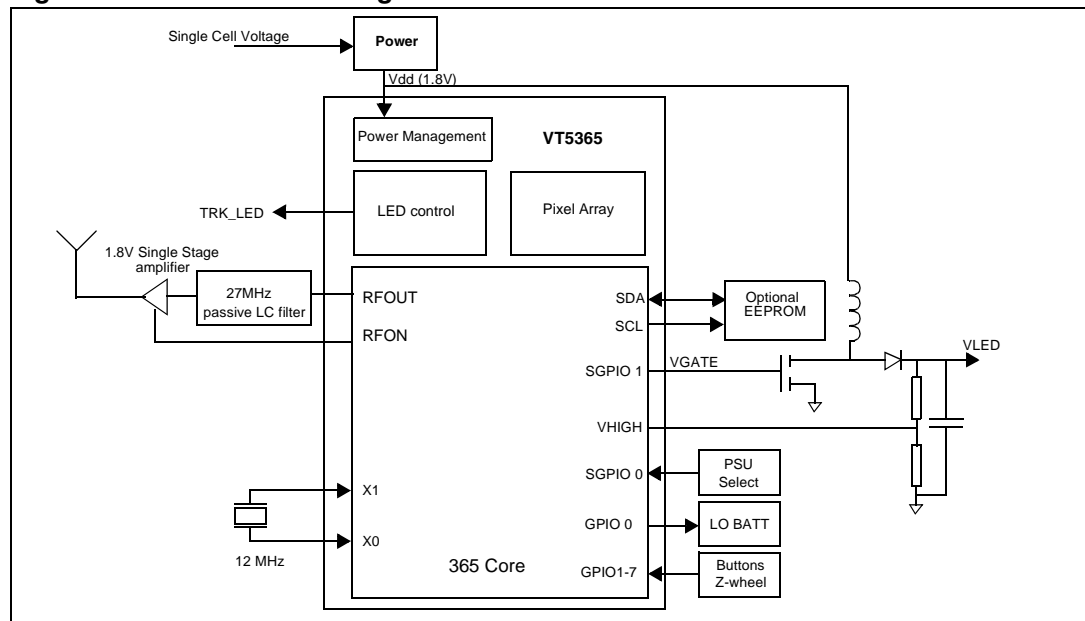
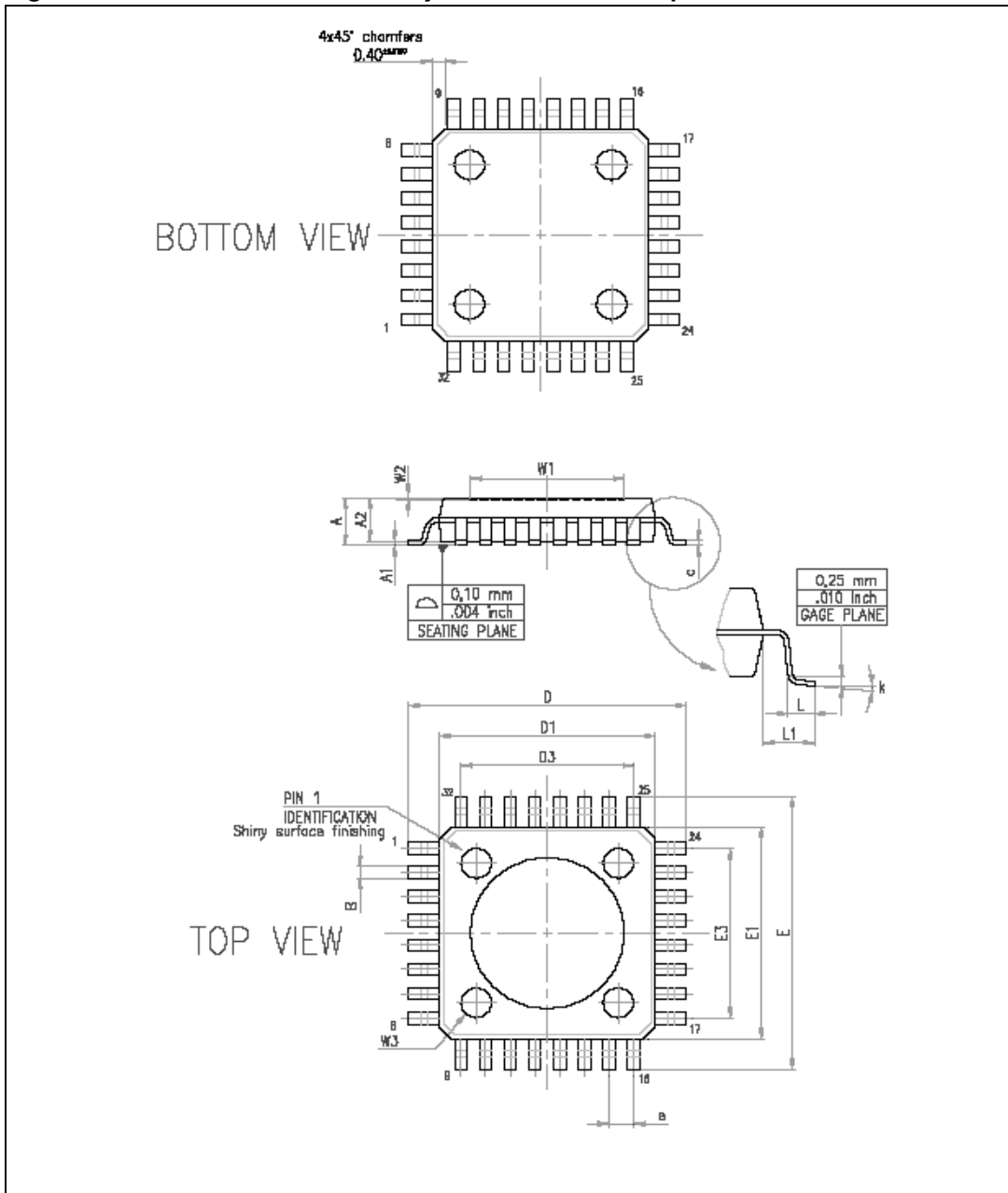

Figure 2. LQFP32 clear resin body 7.0 x 7.0 x 1.40 footprint 1.0



Revision history

Table 1. Document revision history

Date	Revision	Changes
27-Feb-2006	1	Initial release.
13-Jun-2006	2	Updated the supply current values in fast run, slow run and sleep.

Please Read Carefully:

Information in this document is provided solely in connection with ST products. STMicroelectronics NV and its subsidiaries ("ST") reserve the right to make changes, corrections, modifications or improvements, to this document, and the products and services described herein at any time, without notice.

All ST products are sold pursuant to ST's terms and conditions of sale.

Purchasers are solely responsible for the choice, selection and use of the ST products and services described herein, and ST assumes no liability whatsoever relating to the choice, selection or use of the ST products and services described herein.

No license, express or implied, by estoppel or otherwise, to any intellectual property rights is granted under this document. If any part of this document refers to any third party products or services it shall not be deemed a license grant by ST for the use of such third party products or services, or any intellectual property contained therein or considered as a warranty covering the use in any manner whatsoever of such third party products or services or any intellectual property contained therein.

UNLESS OTHERWISE SET FORTH IN ST'S TERMS AND CONDITIONS OF SALE ST DISCLAIMS ANY EXPRESS OR IMPLIED WARRANTY WITH RESPECT TO THE USE AND/OR SALE OF ST PRODUCTS INCLUDING WITHOUT LIMITATION IMPLIED WARRANTIES OF MERCHANTABILITY, FITNESS FOR A PARTICULAR PURPOSE (AND THEIR EQUIVALENTS UNDER THE LAWS OF ANY JURISDICTION), OR INFRINGEMENT OF ANY PATENT, COPYRIGHT OR OTHER INTELLECTUAL PROPERTY RIGHT.

UNLESS EXPRESSLY APPROVED IN WRITING BY AN AUTHORIZED REPRESENTATIVE OF ST, ST PRODUCTS ARE NOT DESIGNED, AUTHORIZED OR WARRANTED FOR USE IN MILITARY, AIR CRAFT, SPACE, LIFE SAVING, OR LIFE SUSTAINING APPLICATIONS, NOR IN PRODUCTS OR SYSTEMS, WHERE FAILURE OR MALFUNCTION MAY RESULT IN PERSONAL INJURY, DEATH, OR SEVERE PROPERTY OR ENVIRONMENTAL DAMAGE.

Resale of ST products with provisions different from the statements and/or technical features set forth in this document shall immediately void any warranty granted by ST for the ST product or service described herein and shall not create or extend in any manner whatsoever, any liability of ST.

ST and the ST logo are trademarks or registered trademarks of ST in various countries.

Information in this document supersedes and replaces all information previously supplied.

The ST logo is a registered trademark of STMicroelectronics. All other names are the property of their respective owners.

© 2006 STMicroelectronics - All rights reserved

STMicroelectronics group of companies

Australia - Belgium - Brazil - Canada - China - Czech Republic - Finland - France - Germany - Hong Kong - India - Israel - Italy - Japan - Malaysia - Malta - Morocco - Singapore - Spain - Sweden - Switzerland - United Kingdom - United States of America

www.st.com