

PACKAGE DIMENSIONS inch (mm)

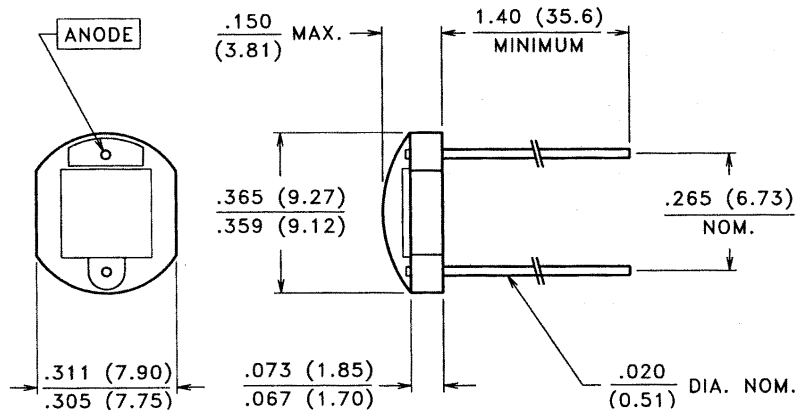

CASE 13 CERAMIC
CHIP ACTIVE AREA: .032 in² (21 mm²)

PRODUCT DESCRIPTION

Large area planar silicon mounted on a two lead ceramic substrate and coated with a layer of clear epoxy. Low junction capacitance permits fast response time.

ABSOLUTE MAXIMUM RATINGS

Storage Temperature: -20°C to 75°C
Operating Temperature: -20°C to 75°C

ELECTRO-OPTICAL CHARACTERISTICS @ 25°C (See also VTP curves, page 46)

SYMBOL	CHARACTERISTIC	TEST CONDITIONS	VTP4085			VTP4085S			UNITS
			Min.	Typ.	Max.	Min.	Typ.	Max.	
I _{SC}	Short Circuit Current	H = 100 fc, 2850		200			200		μA
TC I _{SC}	I _{SC} Temperature Coefficient	2850 K		.20			.20		%/°C
I _{SC}	Short Circuit Current	100 μW/cm ² , 940 nm	11.4	15		11.4	15		μA
V _{OC}	Open Circuit Voltage	H = 100 fc, 2850 K		.33			.33		mV
TC V _{OC}	V _{OC} Temperature Coefficient	2850 K		-2.0			-2.0		mV/°C
I _D	Dark Current	H = 0, V _R = 100 V			100		15	50	nA
R _{SH}	Shunt Resistance	H = 0, V = 10 mV		2.0			4.0		MΩ
TC R _{SH}	R _{SH} Temperature Coefficient	H = 0, V = 10 mV		-11			-11		%/°C
C _J	Junction Capacitance	H = 0, V = 0 V		.35			.35		nF
λ _{range}	Spectral Application Range		400		1100	400		1100	nm
λ _p	Spectral Response - Peak			925			925		nm
S _R	Sensitivity	@ Peak		.55			.55		A/W