

Helping Customers Innovate, Improve & Grow



VX-509

Features

- 9x14 J Leaded Surface Mount Package
- 4 Point Crystal Mount / Swept Quartz³
- Class S Screening IAW MIL-PRF-55310
- 100 krad Total Dose Radiation Tolerance³
- Frequency Range: 1 MHz to 85 MHz
- Previous Model: 5116

Applications

- Mil/Space Applications
- Satellite Applications
- Rad Hard Environments

Performance Specifications

Parameter	Min	Typ	Max	Units	Condition
Frequency Stabilities¹					
vs. operating temperature range (absolute pull range)	-30		+30	ppm	0... +70°C
	-30		+30	ppm	-20... +70°C
	-30		+30	ppm	-40... +85°C
	-50		+50	ppm	0... +70°C
	-50		+50	ppm	-20... +70°C
	-50		+50	ppm	-40... +85°C
Supply Voltage (Vs)					
Supply voltage	4.75	5.0	5.25	VDC	
Current consumption (no load)			15	mA	1.0 to 23.9 MHz
			20	mA	24 to 49.9 MHz
			40	mA	50 to 85.0 MHz
Supply voltage	3.135	3.3	3.465	VDC	
Current consumption (no load)			6	mA	1.0 to 14.9 MHz
			8	mA	15.0 TO 39.9 MHz
			12	mA	40.0 TO 59.9 MHz
			16	mA	60.0 TO 85.0 MHz
RF Output					
Signal	ACMOS				
Load	15		50	pF	
Signal Level (Vol)			0.5	VDC	Vs= 5.0V and 15pF load
			0.3	VDC	Vs= 3.3V and 15pF load

Performance Specifications

Parameter	Min	Typ	Max	Units	Condition
Signal Level (Voh)	4.5 3.0			VDC VDC	Vs= 5.0V and 15pF load Vs= 3.3V and 15pF load
Rise and fall times for AC MOS (measured 10% to 90%)			10 5	ns ns	1.0 to 23.9 MHz 24.0 to 85.0 MHz
Duty cycle	45 40		55 60	% %	@ 50% Vs < 15 MHz @ 50% Vs >= 15 MHz
Frequency Tuning (EFC)					
Linearity		10	15	%	
Tuning Slope	Positive				
Control Voltage Range	0.5 0.3	2.5 1.65	4.5 3.0	VDC VDC	with Vs=5.0VDC with Vs=3.3VDC
Additional Parameters					
Phase Noise ³ (@ 52 MHz)			-60 -90 -120 -140 -145	dBc/Hz dBc/Hz dBc/Hz dBc/Hz dBc/Hz	10 Hz 100 Hz 1 KHz 10 KHz 100 KHz
Weight			<2.0	g	
Absolute Maximum Ratings					
Supply voltage (Vs)			7.0	V	
Operable temperature range	-55		+85	°C	
Storage temperature range	-55		+125	°C	
Screening Level					
Class S Screening	IAW MIL-PRF-55310				
Class B Screening	IAW MIL-PRF-55310				
Engineering Model	No Screening				

Outline Drawing / Enclosure

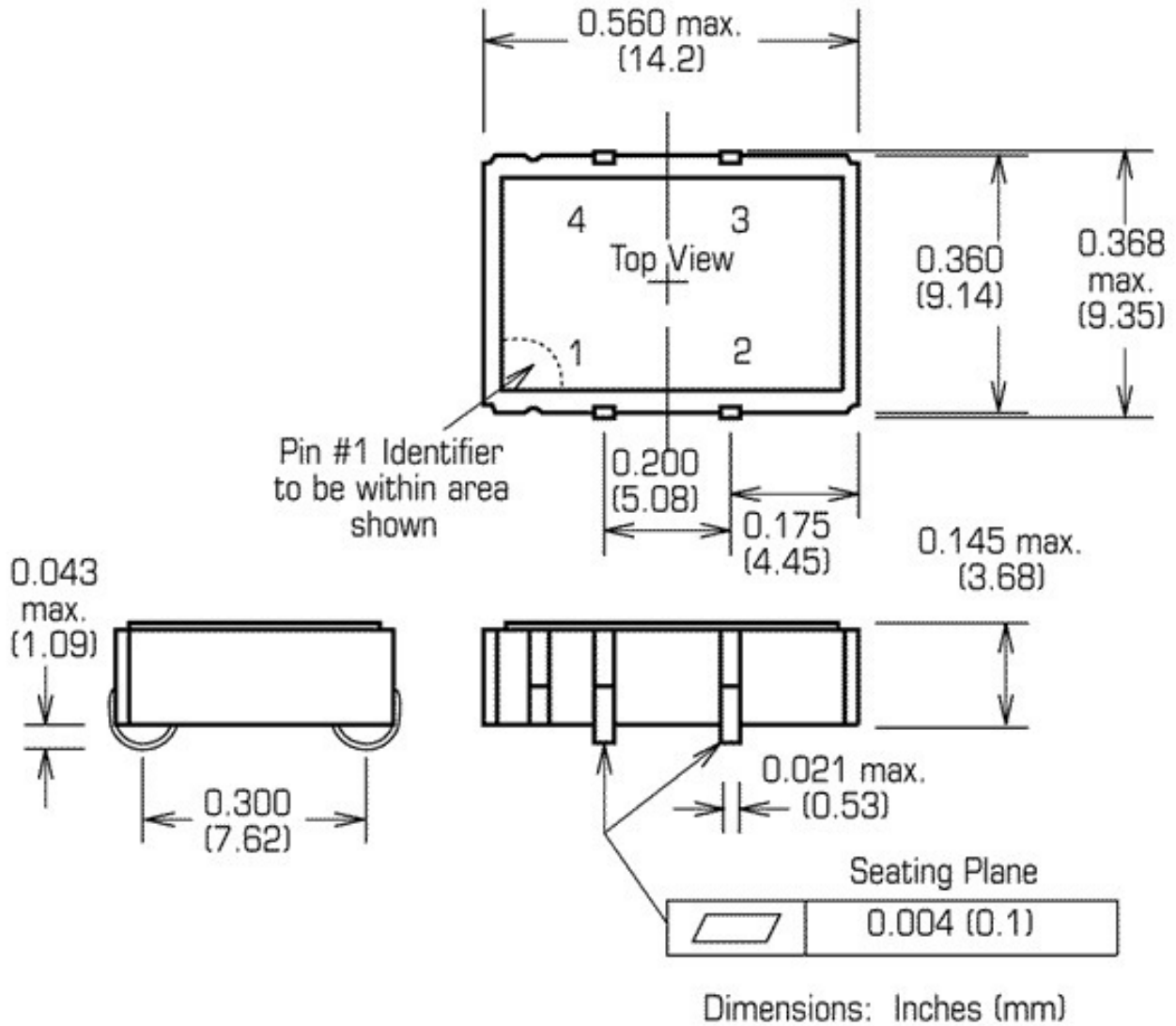

Type B		
Code	Height "H"	Stand-off
0	0.188"	0.043"

Pin Connections	
1	VCXO input
2	Ground (Case)
3	RF Output
4	Supply

Ordering Information

VX - 509 0 - D A J - K X S X - 10M000000

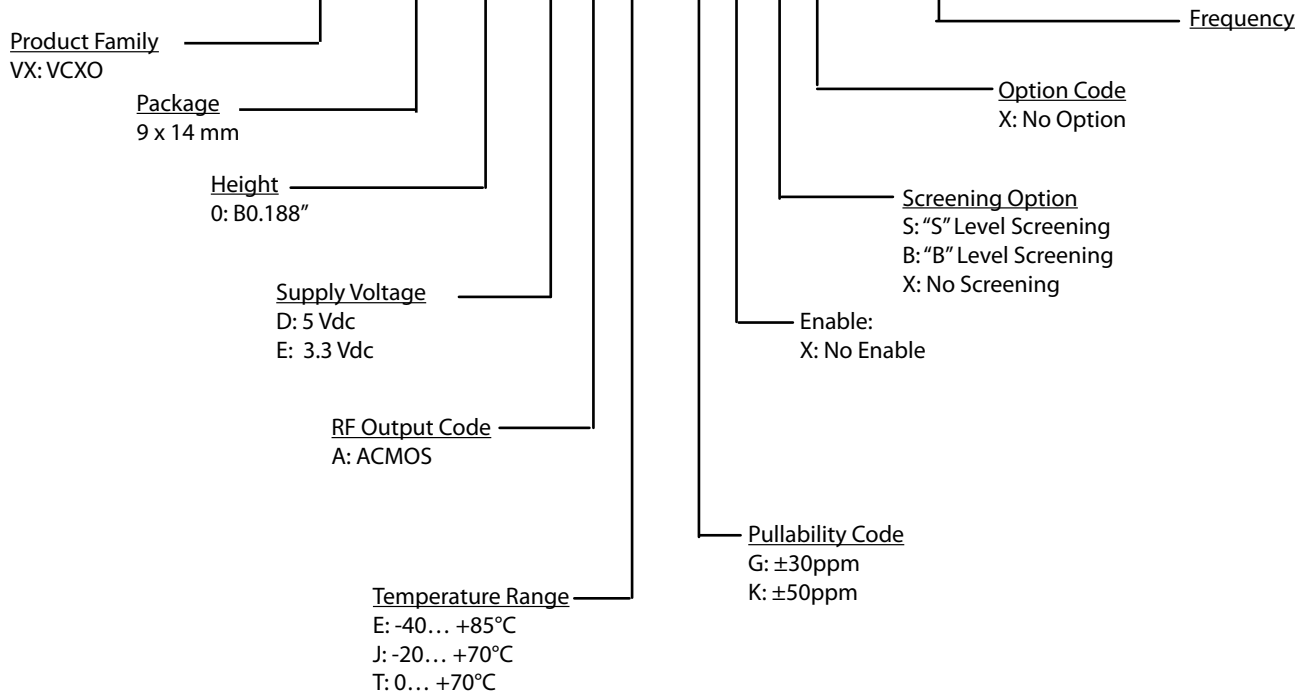

Notes:

1. Contact factory for improved stabilities or additional product options. Not all options and codes are available at all frequencies.
2. Unless other stated all values are valid after warm-up time and refer to typical conditions for supply voltage, frequency control voltage, load, temperature (25°C).
3. Phase noise degrades with increasing output frequency.
4. Subject to technical modification.
5. Contact factory for availability.

For Additional Information, Please Contact

USA:

Vectron International
 267 Lowell Road
 Hudson, NH 03051
 Tel: 1.888.328.7661
 Fax: 1.888.329.8328

Europe:

Vectron International
 Landstrasse, D-74924
 Neckarbischofsheim, Germany
 Tel: +49 (0) 3328.4784.17
 Fax: +49 (0) 3328.4784.30

Asia:

Vectron International
 1F-2F, No 8 Workshop, No 308 Fenju Road
 WaiGaoQiao Free Trade Zone
 Pudong, Shanghai, China 200131
 Tel: 86.21.5048.0777
 Fax: 86.21.5048.1881

Disclaimer

Vectron International reserves the right to make changes to the product(s) and or information contained herein without notice. No liability is assumed as a result of their use or application. No rights under any patent accompany the sale of any such product(s) or information.