

# Direct Operated 3 Port Solenoid Valve

For Water, Oil, Steam, Air

Reduction of  
power consumption  
(DC specification)

6 W → **4.5 w**

8 W → **7 w**

11.5 W → **10.5 w**



New

**VX3**

Series **VX31/32/33**

# Solenoid valves for various fluids used in a wide variety of

**Improvement of corrosion resistance**

Special magnetic material adopted

**Enclosure: Equivalent to IP65**

**Low noise construction**

Special construction enables to reduce the metal noise. (DC specification)

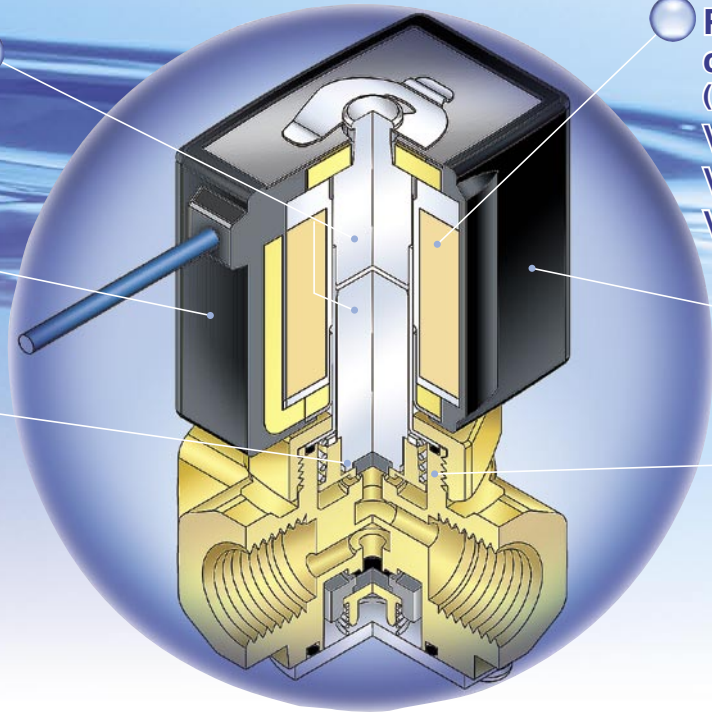

**Reduction of power consumption (DC specification)**

VX31: 6 w → **4.5 w**

VX32: 8 w → **7 w**

VX33: 11.5 w → **10.5 w**

**Flame resistance UL94V-0 conformed**

Flame resistant mold coil material

**Improvement of maintenance performance**

Maintenance is performed easily due to the threaded assembly.

## Direct Operated 3 Port Solenoid Valve

For Water, Oil, Steam, Air

**New Series VX31/32/33**

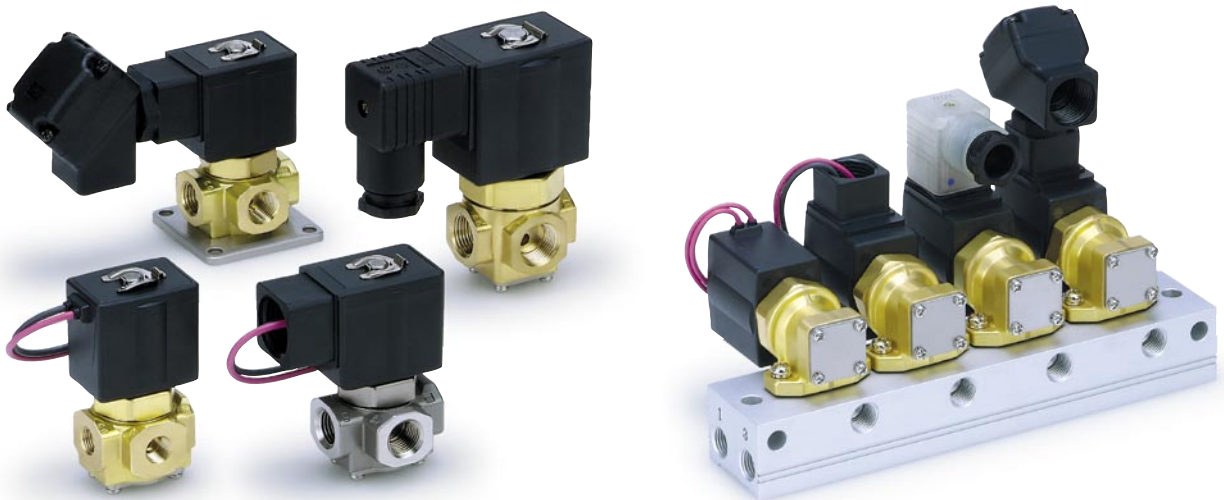

### Normally Closed (N.C.) / Normally Open (N.O.) / Common (COM.)

Model	Orifice size				Port size	Material				Fluid
	1.5 mmø	2.2 mmø	3 mmø	4 mmø		Body	Guide pin	Seal		
VX31	●	●	●	—	1/8, 1/4	Brass	PPS	NBR	NBR	Water, Oil, Steam, Air
VX32	—	●	●	●	1/4, 3/8	Stainless steel	Stainless steel	FKM	FKM	
VX33	—	●	●	●	1/4, 3/8	Stainless steel	Stainless steel	EPDM	EPDM	
								FFKM	PTFE	

### Manifold: Normally Closed (N.C.) / Normally Open (N.O.) / Common (COM.)

Model	Orifice size				Port size (Common SUP/EXH type)			Material			Fluid	
	1.5 mmø	2.2 mmø	3 mmø	4 mmø	IN port	OUT port	EXH port	Body	Guide pin	Seal		
VVX31	●	●	●	—	1/4	1/8, 1/4	1/4	Brass	PPS	Stainless steel	NBR	Oil, Air
VVX32	—	●	●	●								
VVX33	—	●	●	●								

# applications—New **VX** Series variations

## Direct Operated 2 Port

### VX21/22/23

For Air, Vacuum, Water, Steam, Oil



Valve type	Port size	Orifice size mmØ
N.C./N.O.	1/8 to 1/2	2 to 10

## Pilot Operated 2 Port

### VXD21/22/23

For Air, Water, Oil



Valve type	Port size	Orifice size mmØ
N.C./N.O.	1/4 to 1 32 A to 50 A	10 to 50

## Pilot Operated 2 Port for Zero Differential Pressure

### VXZ22/23

For Air, Vacuum, Water, Oil



Valve type	Port size	Orifice size mmØ
N.C./N.O.	1/4 to 1	10 to 25

## Pilot Operated 2 Port

### VXP21/22/23

For Steam (Air, Water, Oil)



Valve type	Port size	Orifice size mmØ
N.C./N.O.	1/4 to 2 32 A to 50 A	10 to 50

## Water Hammer Relief, Pilot Operated 2 Port

### VXR21/22/23

For Water, Oil



Valve type	Port size	Orifice size mmØ
N.C./N.O.	1/2 to 2	20 to 50

## Pilot Operated 2 Port for High Pressure

### VXH22

For Air, Water, Oil

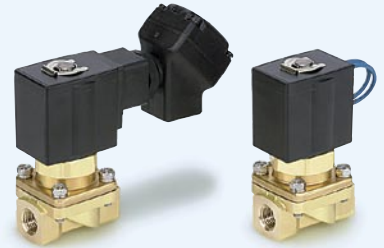

Valve type	Port size	Orifice size mmØ
N.C.	1/4 to 1/2	10

## 2 Port for Dust Collector (Solenoid type, Air Operated type)

### VXF21/22, VXFA21/22

For Air

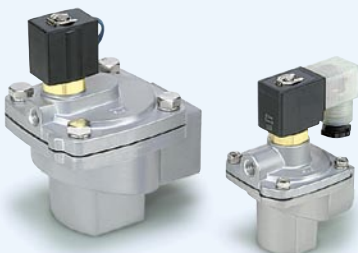

Valve type	Port size	Orifice size mmØ
N.C.	3/4 to 1 1/2	20 to 40

## Air Operated 2/3 Port

### VXA21/22, VXA31/32

For Air, Vacuum, Water, Oil



Model	Valve type	Port size	Orifice size mmØ
VXA21/22	N.C./N.O.	1/8 to 1/2	3 to 10
VXA31/32	COM.	1/8 to 3/8	1.5 to 4

The VX series has been renewed as the **new VX series**, with a new construction

# Solenoid Valves Flow Characteristics

## (How to indicate flow characteristics)

### 1. Indication of flow characteristics

Indication of the flow characteristics in specifications for equipment such as a solenoid valve, etc. is depending on "Table (1)".

Table (1) Indication of Flow Characteristics

Corresponding equipment	Indication by international standard	Other indications	Standards conforming to
Equipment for pneumatics	$C, b$	—	ISO 6358: 1989 JIS B 8390: 2000
	—	$S$	JIS B 8390: 2000 Equipment: JIS B 8373, 8374, 8375, 8379, 8381
		$C_v$	ANSI/(NFPA)T3.21.3: 1990
Equipment for controlling process fluids	$A_v$	—	IEC60534-2-3: 1997 JIS B 2005: 1995
	—	$C_v$	Equipment: JIS B 8471, 8472, 8473

### 2. Equipment for pneumatics

#### 2.1 Indication according to the international standards

(1) Standards conforming to

**ISO 6358: 1989** : Pneumatic fluid power—Components using compressible fluids—  
Determination of flow-rate characteristics

**JIS B 8390: 2000** : Pneumatic fluid power—Components using compressible fluids—  
How to test flow-rate characteristics

(2) Definition of flow characteristics

Flow rate characteristics are indicated as a result of a comparison between sonic conductance  $C$  and critical pressure ratio  $b$ .  
Sonic conductance  $C$  : Value which divides the passing mass flow rate of an equipment in a choked flow condition by the product of the absolute upstream pressure and the density in the standard condition.

Critical pressure ratio  $b$  : Choked flow will occur when the pressure ratio (downstream pressure/upstream pressure) is at or smaller than this value.

Choked flow : It is the flow in which the upstream pressure is higher than the downstream pressure and where sonic speed is reached in a certain part of the equipment.  
Gaseous mass flow rate is in proportion to the upstream pressure and not dependent on the downstream pressure.

Subsonic flow : Flow when the pressure ratio is greater than the critical pressure ratio.

Standard condition : Air in a temperature state of 20°C, absolute pressure 0.1 MPa (= 100 kPa = 1 bar), relative humidity 65%.

It is stipulated by adding the abbreviation (ANR) after the unit depicting air volume.  
(standard reference atmosphere)

Standard conforming to: ISO 8778: 1990 Pneumatic fluid power—Standard reference atmosphere,  
JIS B 8393: 2000: Pneumatic fluid power—Standard reference atmosphere

(3) Formula of flow rate

It can be indicated by the practical unit as following.

When

$$\frac{P_2 + 0.1}{P_1 + 0.1} \leq b, \text{ choked flow}$$

$$Q = 600 \times C (P_1 + 0.1) \sqrt{\frac{293}{273 + t}} \dots\dots\dots(1)$$

When

$$\frac{P_2 + 0.1}{P_1 + 0.1} > b, \text{ subsonic flow}$$

$$Q = 600 \times C (P_1 + 0.1) \sqrt{1 - \left[ \frac{\frac{P_2 + 0.1}{P_1 + 0.1} - b}{1 - b} \right]^2} \sqrt{\frac{293}{273 + t}} \dots\dots\dots(2)$$

$Q$  : Air flow rate [dm<sup>3</sup>/min (ANR)], the SI unit dm<sup>3</sup> (Cubic decimetre) is also allowed to be described by ℓ (liter). 1 dm<sup>3</sup> = 1 ℓ.

# Solenoid Valves Flow Characteristics

$C$  : Sonic conductance [ $\text{dm}^3/(\text{s}\cdot\text{bar})$ ]

$b$  : Critical pressure ratio [—]

$P_1$  : Upstream pressure [MPa]

$P_2$  : Downstream pressure [MPa]

$t$  : Temperature [ $^{\circ}\text{C}$ ]

Note) Formula of subsonic flow is the elliptic analogous curve.

Flow characteristics curve is indicated in the Graph (1) For details, please use SMC's "Energy Saving Program".

Example)

Obtain the air flow rate when  $P_1 = 0.4$  [MPa],  $P_2 = 0.3$  [MPa],  $t = 20$  [ $^{\circ}\text{C}$ ] for a solenoid valve where  $C = 2$  [ $\text{dm}^3/(\text{s}\cdot\text{bar})$ ] and  $b = 0.3$ .

According to formula (1), the maximum flow rate =  $600 \times 2 \times (0.4 + 0.1) \times \sqrt{\frac{293}{273 + 20}} = 600$  [ $\text{dm}^3/\text{min}$  (ANR)]

$$\text{Pressure ratio} = \frac{0.3 + 0.1}{0.4 + 0.1} = 0.8$$

Based on the Graph (1), the flow rate ratio is going to be 0.7 if it is read with a pressure ratio of 0.8 and a flow ratio of  $b = 0.3$ .  
Hence, flow rate = Max. flow rate  $\times$  flow rate ratio =  $600 \times 0.7 = 420$  [ $\text{dm}^3/\text{min}$  (ANR)]

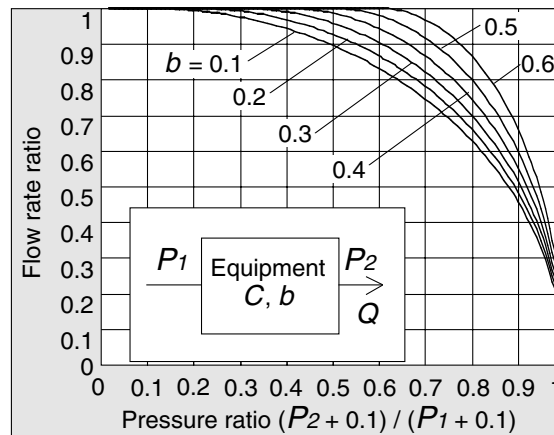

Graph (1) Flow characteristics line

#### (4) Test method

Pipe the text equipment to the test circuit shown in Fig. (1). Keep the upstream pressure at a certain constant level above 0.3MPa. First measure the maximum flow rate in saturation. Then, measure the flow rate, upstream pressure and downstream pressure each at 80%, 60%, 40% and 20% points of the flow rate. Calculate the sonic conductance  $C$  from the maximum flow rate. Also substitute other data for variables in the formula for subsonic flow and obtain the critical pressure rate  $b$  by averaging the critical pressure rates at those points.

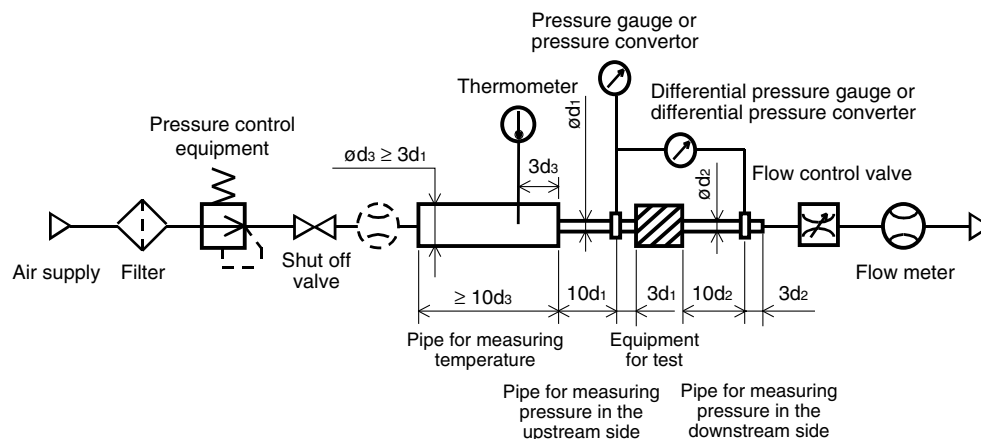

Fig. (1) Test circuit based on ISO 6358, JIS B 8390

# Solenoid Valves Flow Characteristics

## (How to indicate flow characteristics)

### 2.2 Effective area *S*

(1) Standards conforming to

**JIS B 8390: 2000: Pneumatic fluid power—Components using compressible fluids—  
Determination of flow rate characteristics**

**Equipment standards: JIS B 8373: 2 port solenoid valve for pneumatics**

**JIS B 8374: 3 port solenoid valve for pneumatics**

**JIS B 8375: 4 port, 5 port solenoid valve for pneumatics**

**JIS B 8379: Silencer for pneumatics**

**JIS B 8381: Fittings of flexible joint for pneumatics**

(2) Definition of flow characteristics

Effective area *S*: The flow ability of a component, represented by its equivalent "ideal" cross sectional area. This effective area is calculated under sonic conditions by measuring pressure loss in an air tank. Like sonic conductance *C*, the effective area is a method of expressing the flow rate of a product.

(3) Formula of flow rate

When

$$\frac{P_2 + 0.1}{P_1 + 0.1} \leq 0.5, \text{ choked flow}$$

$$Q = 120 \times S (P_1 + 0.1) \sqrt{\frac{293}{273 + t}} \dots \dots \dots (3)$$

When

$$\frac{P_2 + 0.1}{P_1 + 0.1} > 0.5, \text{ subsonic flow}$$

$$Q = 240 \times S \sqrt{(P_2 + 0.1)(P_1 - P_2)} \sqrt{\frac{293}{273 + t}} \dots \dots \dots (4)$$

Conversion with sonic conductance *C*:

$$S = 5.0 \times C \dots \dots \dots (5)$$

*Q* : Air flow rate [dm<sup>3</sup>/min(ANR)], the SI unit dm<sup>3</sup> (cubic decimetre) is also allowed to be described by ℓ (litre)

*S* : Effective area [mm<sup>2</sup>]

*P*<sub>1</sub> : Upstream pressure [MPa]

*P*<sub>2</sub> : Downstream pressure [MPa]

*t* : Temperature [°C]

Note) Formula for subsonic flow (4) is only applicable when the critical pressure ratio *b* is unknown. It is the same as the formula for sonic conductance *C* (2) only when *b*=0.5

(4) Test method

Pipe the test equipment to the test circuit shown in Fig. (2). Fill the air tank with compressed air and keep the pressure at a constant level above 0.6MPa (0.5MPa). Then discharge the air until the pressure in the tank drops to 0.25MPa (0.2MPa). Measure the time required to discharge the air and the residual pressure in the air tank after leaving it until the pressure becomes stable in order to calculate the effective sectional area *S* by the following formula. Select the capacity of the air tank according to the effective sectional area of the test equipment. In the case of JIS B 8373, 8374, 8375, 8379, 8381, the pressure values are in parentheses and the coefficient of formula is 12.9.

$$S = 12.1 \frac{V}{t} \log_{10} \left( \frac{P_s + 0.1}{P + 0.1} \right) \sqrt{\frac{293}{T}} \dots \dots \dots (6)$$

*S* : Effective area [mm<sup>2</sup>]

*V* : Air tank capacity [dm<sup>3</sup>]

*t* : Discharging time [s]

*P*<sub>s</sub> : Pressure inside air tank before discharging [MPa]

*P* : Residual pressure inside air tank after discharging [MPa]

*T* : Temperature inside air tank before discharging [K]

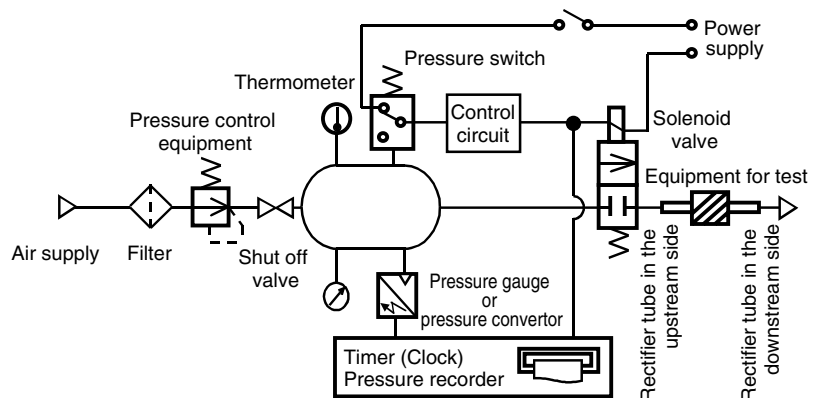

Fig. (2) Test circuit based on JIS B 8390

# Solenoid Valves Flow Characteristics

## 2.3 Flow coefficient $C_v$ factor

### The United States Standard ANSI(NFPA)T3.21.3:1990: Pneumatic fluid power—Flow rating test procedure and reporting method for fixed orifice components

defines the flow coefficient  $C_v$  factor by the following formula which is based on testing conducted with a test circuit analogous to ISO 6358.

$$C_v = \frac{Q}{114.5 \sqrt{\frac{\Delta P (P_2 + P_a)}{T_1}}} \dots\dots\dots(7)$$

$\Delta P$  : Pressure drop between the static pressure tapping ports [bar]

$P_1$  : Pressure of the upstream tapping port [bar gauge]

$P_2$  : Pressure of the downstream tapping port [bar gauge]:  $P_2 = P_1 - \Delta P$

$Q$  : Flow rate [dm<sup>3</sup>/s standard condition]

$P_a$  : Atmospheric pressure [bar absolute]

$T_1$  : Upstream absolute temperature [K]

Test conditions are  $< P_1 + P_a = 6.5 \pm 0.2$  bar absolute,  $T_1 = 297 \pm 5$ K,  $0.07 \text{ bar} \leq \Delta P \leq 0.14$  bar.

This is the same concept as effective area  $A$  which ISO6358 stipulates as being applicable only when the pressure drop is small in relation to the upstream pressure so that the compression of air is negligible.

## 3. Equipment for process fluids

(1) Standards conforming to

**IEC60534-2-3: 1997: Industrial process control valves. Part 2: Flow capacity, Section Three-Test procedures**

**JIS B 2005: 1995: Test method for the flow coefficient of a valve**

**Equipment standards: JIS B 8471: Regulator for water**

**JIS B 8472: Solenoid valve for steam**

**JIS B 8473: Solenoid valve for fuel oil**

(2) Definition of flow characteristics

$Av$  factor: It is the value representing the flow of clean water in m<sup>3</sup>/s which runs through a valve (equipment for test) when the pressure difference is 1 Pa. It is calculated using the following formula.

$$Av = Q \sqrt{\frac{\rho}{\Delta P}} \dots\dots\dots(8)$$

$Av$  : Flow coefficient [m<sup>2</sup>]

$Q$  : Flow rate [m<sup>3</sup>/s]

$\Delta P$  : Pressure difference [Pa]

$\rho$  : Density of fluid [kg/m<sup>3</sup>]

(3) Formula of flow rate

It is described by the known unit. Also, the flow characteristics line shown in the Graph (2).

In the case of liquid:

$$Q = 1.9 \times 10^6 Av \sqrt{\frac{\Delta P}{G}} \dots\dots\dots(9)$$

$Q$  : Flow rate [ℓ/min]

$Av$  : Flow coefficient [m<sup>2</sup>]

$\Delta P$  : Pressure difference [MPa]

$G$  : Relative density [water = 1]

In the case of saturated aqueous vapour:

$$Q = 8.3 \times 10^6 Av \sqrt{\Delta P (P_2 + 0.1)} \dots\dots\dots(10)$$

$Q$  : Flow rate [kg/h]

$Av$  : Flow coefficient [m<sup>2</sup>]

$\Delta P$  : Pressure difference [MPa]

$P_1$  : Upstream pressure [MPa]:  $\Delta P = P_1 - P_2$

$P_2$  : Downstream pressure [MPa]

# Solenoid Valves Flow Characteristics

## (How to indicate flow characteristics)

Conversion of flow coefficient:

$$Av = 28 \times 10^{-6} Kv = 24 \times 10^{-6} Cv \dots\dots\dots(11)$$

Here,

**KV** factor: It is the value representing the flow rate of clean water in m<sup>3</sup>/h which runs through the valve at 5 to 40°C, when the pressure difference is 1 bar.

**Cv** factor (Reference values): It is the value representing the flow rate of clean water in US gal/min which runs through the valve at 60°F, when the pressure difference is 1 lbf/in<sup>2</sup> (psi).

Values of pneumatic **KV** are different from **Cv** because the testing method is different from each other.

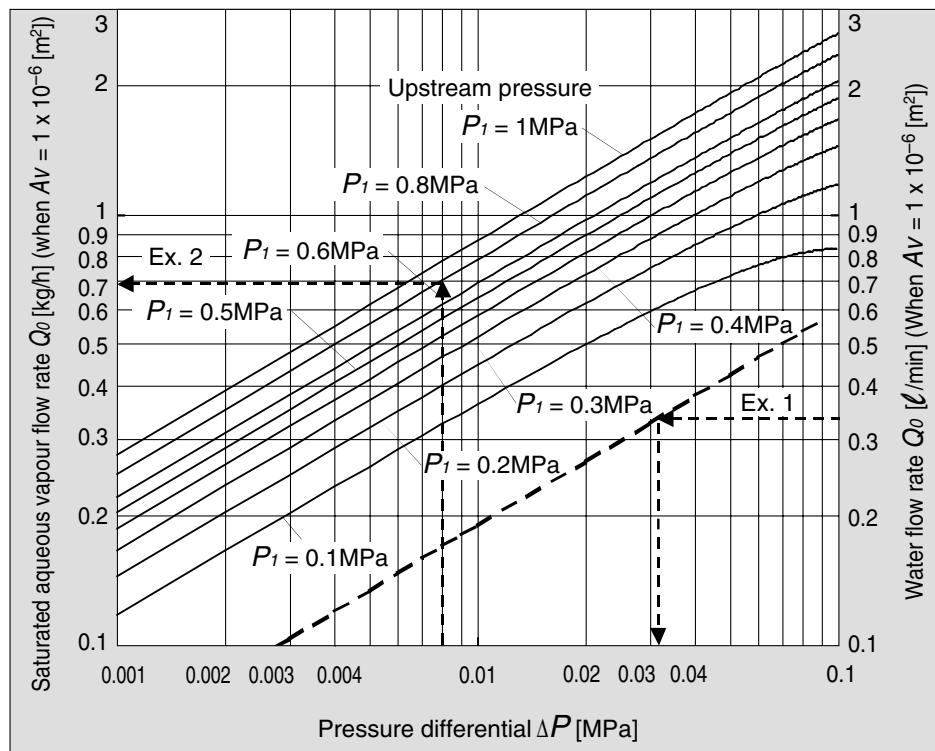

**Graph (2) Flow characteristics line**

Example 1)

Obtain the pressure difference when 15 [l/min] of water runs through the solenoid valve with an  $Av = 45 \times 10^{-6} [m^2]$ . Since  $Q_0 = 15/45 = 0.33 [l/min]$ , according to the Graph (2), if reading  $\Delta P$  when  $Q_0$  is 0.33, it will be 0.031 [MPa].

Example 2)

Obtain the flow rate of saturated aqueous vapour when  $P_1 = 0.8 [MPa]$ ,  $\Delta P = 0.008 [MPa]$  with a solenoid valve with an  $Av = 1.5 \times 10^{-6} [m^2]$ .

According to the Graph (2), if reading  $Q_0$  when  $P_1$  is 0.8 and  $\Delta P$  is 0.008, it is 0.7 [kg/h]. Hence, the flow rate  $Q = 0.7 \times 1.5 = 1.05 [kg/h]$ .



# Solenoid Valves Flow Characteristics

## (4) Test method

By attaching the equipment for testing with the test circuit shown in Fig. (3) and running water at 5 to 40°C, measure the flow rate with a pressure difference of 0.075 MPa. However, the pressure difference needs to be set with a large enough difference so that the Reynolds number does not go below a range of  $4 \times 10^4$ .

By substituting the measurement results for formula (8) to figure out  $Av$ .

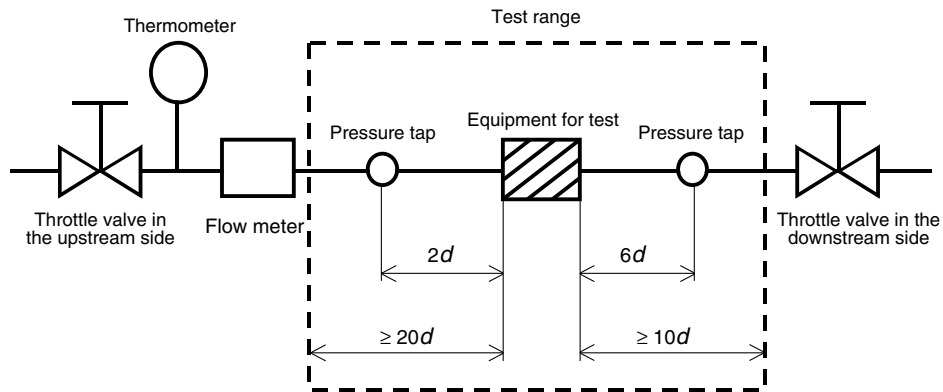
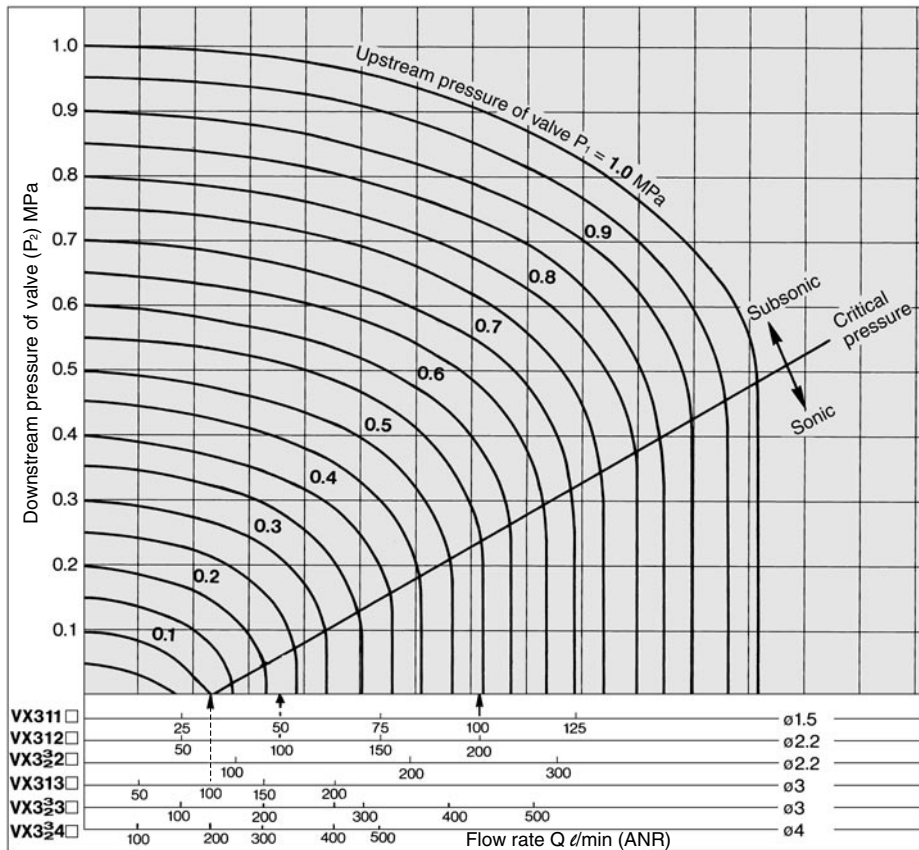

**Fig. (3) Test circuit based on IEC60534-2-3, JIS B 2005**

# Flow Characteristics

Note) Use this graph as a guide. In the case of obtaining an accurate flow rate, refer to front matter pages 1 to 6.

## For Air



### How to read the graph

The sonic range pressure to generate a flow rate of 100 l/min (ANR) is  
 $P_1 \approx 0.1$  MPa for a ø3 orifice (VX313□),  
 $P_1 \approx 0.23$  MPa for a ø2.2 orifice (VX312□), and  
 $P_1 \approx 0.55$  MPa for a ø1.5 orifice (VX311□).

## For Water

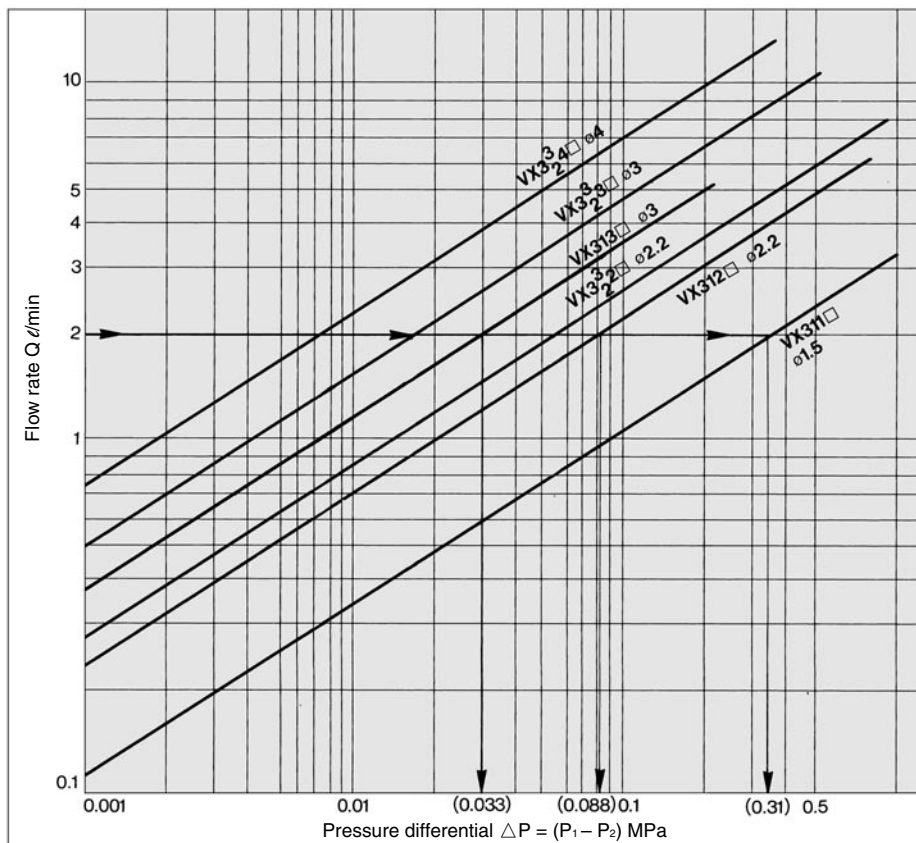

### How to read the graph

When a water flow of 2 l/min is generated,  
 $\Delta P \approx 0.033$  MPa for a ø3 orifice (VX313□),  
 $\Delta P \approx 0.088$  MPa for a ø2.2 orifice (VX312□), and  
 $\Delta P \approx 0.31$  MPa for a ø1.5 orifice (VX311□).

# Applicable Fluid Check List

## Single Unit Series VX31/32/33

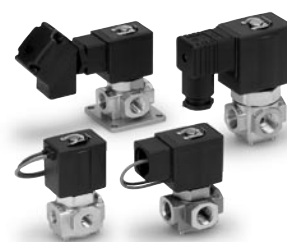

### All Options (Single Unit)

Option symbol	Seal material		Body material /Shading coil material	Guide pin material	Coil insulation type	Note
	Main valve poppet	Fixed Seals				
Standard	NBR	NBR	Brass (C37)	PPS	B	—
A	FKM	FKM				
B	EPDM	EPDM				
C	FFKM	PTFE	Brass (C37)/ Copper	Stainless steel	H	
D	FKM	FKM				
E	EPDM	EPDM	Stainless steel	PPS	B	
G	NBR	NBR				
H	FKM	FKM				
J	EPDM	EPDM				
K	FFKM	PTFE		Stainless steel		Oil free
M	FKM	FKM		PPS		Non-leak, Oil free
N	FKM	FKM	Stainless steel/Silver	Stainless steel	H	—
P	EPDM	EPDM				
Q	FFKM	PTFE				
S	FFKM	PTFE	Brass (C37)/ Copper			Steam (Max. 183°C)
V	FKM	FKM	Brass (C37)	PPS	B	Non-leak, Oil free

\* "K", "M", "V" options are for non-lube treatment.

### Fluid Name and Option (Single Unit)

Fluid (Application)	Option symbol and body material	
	Brass (C37)	Stainless steel
Caustic soda (25% ≥)	—	J
Gas oil	A	H
Silicon oil	A	H
Steam system (Steam) (Max. 183°C)	S	Q
Steam system (Condensation) (Max. 99°C)	E	P
Vacuum system (for pad)	Standard	—
Medium vacuum (up to 0.1 Pa.abs)	V	M
Perchloroethylene	A	H
Helium	V	M
Non-leak (10 <sup>-6</sup> Pa·m <sup>3</sup> /s)	V	M
Heated water (Max. 99°C)	E	P

Note 1) The leakage amount (10<sup>-6</sup>Pa·m<sup>3</sup>/s) of "V", "M" options are values when differential pressure is 0.1 MPa.  
Note 2) If using for other fluids, contact SMC.

## Manifold Series VVX31/32/33



### All Options (Manifold)

Option symbol	Seal material		Body material /Shading coil material	Guide pin material	Coil insulation type	Note
	Main valve poppet	Fixed seals				
Standard	NBR	NBR	Brass (C37)	PPS	B	—
A	FKM	FKM				
B	EPDM	EPDM				
D	FKM	FKM	Brass (C37)/ Copper	Stainless steel	H	
E	EPDM	EPDM				
V	FKM	FKM	Brass (C37)	PPS	B	

\* Aluminum is the only available material for the manifold base.

### Fluid Name and Option (Manifold)

Fluid (Application)	Option symbol
Gas oil	A
Silicon oil	A
Vacuum system (for pad)	Standard
Medium vacuum (up to 0.1 Pa.abs)	V
Perchloroethylene	A
Helium	V
Non-leak (10 <sup>-6</sup> Pa·m <sup>3</sup> /s)	V

Note 1) The leakage amount (10<sup>-6</sup>Pa·m<sup>3</sup>/s) of "V" options are values when differential pressure is 0.1 MPa.  
Note 2) If using for other fluids, contact SMC.

# Glossary of Terms

## Pressure Terminology

### 1. Maximum operating pressure differential

The maximum pressure differential (the difference between the inlet and outlet pressure) which is allowed for operation, with the valve closed or open. When the downstream pressure is 0 MPa, this becomes the maximum operating pressure.

### 2. Minimum operating pressure differential

The minimum pressure differential (difference between the inlet pressure and the outlet pressure) required to keep the main valve fully opened.

### 3. Maximum system pressure

The maximum pressure that can be applied inside the pipelines (line pressure).  
(The pressure differential of the solenoid valve unit must be less than the maximum operating pressure differential.)

### 4. Withstand pressure

The pressure which must be withstood without a drop in performance after returning to the operating pressure range. (value under the prescribed conditions)

## Electrical Terminology

### 1. Apparent power (VA)

Volt-ampere is the product of voltage (V) and current (A). Power dissipation (W): For AC,  $W = V \cdot A \cdot \cos\theta$ . For DC,  $W = V \cdot A$ .  
(Note)  $\cos\theta$  shows power factor.  $\cos\theta = 0.6$

### 2. Surge voltage

A high voltage which is momentarily generated in the shut-off unit by shutting off the power.

### 3. Degree of protection

A degree defined in the "JIS C 0920: Waterproof test of electric machinery/appliance and the degree of protection against the intrusion of solid foreign objects".

IP65: Dust-tight, Low jetproof type

"Low jetproof type" means that no water intrudes inside the equipment that could hinder it from operating normally by means of discharging water for 3 minutes in the prescribed manner. Take appropriate protection measures, since a device is not usable in an environment where a water drop is splashed.

## Others

### 1. Material

NBR: Nitrile rubber

FKM: Fluoro rubber – Trade names: Viton®, Dai-el®, etc.

EPDM: Ethylene propylene rubber

PTFE: Polytetrafluoroethylene resin – Trade names: Teflon®, Polyflon®, etc.

FFKM: Perfluoroelastomer  
Trade names: Kalrez®, Chemraz®

### 2. Oil free treatment

The degreasing and washing of wetted parts.

### 3. Passage symbol

In the JIS symbol (  $\square \square \square \square$  ) IN and OUT are in a blocked condition (  $\frac{\square}{\square}$  ), but actually in the case of reverse pressure (OUT>IN), there is a limit to the blocking.

(  $\triangle$  ) is used to indicate that blocking of reverse pressure is not possible.

# Direct Operated 3 Port Solenoid Valve

## Series VX31/32/33

For Water, Oil, Steam, Air



### Single Unit

#### Valve

Normally closed (N.C.)  
Normally open (N.O.)  
Common (COM.)

#### Solenoid Coil

Coil: Class B, Class H

#### Rated Voltage

100 VAC, 200 VAC, 110 VAC,  
220 VAC, 240 VAC, 230 VAC,  
48 VAC, 24 VDC, 12 VDC

#### Material

Body — Brass, Stainless steel  
Seal — NBR, FKM, EPDM, PTFE, FFKM

#### Electrical Entry

- Grommet
- Conduit
- DIN terminal
- Conduit terminal



Normally Closed (N.C.) /  
Normally Open (N.O.) /  
Common (COM.)

Model	VX31	VX32	VX33
Orifice size	1.5 mmø	●	—
	2.2 mmø	●	●
	3 mmø	●	●
	4 mmø	—	●
Port size	1/8, 1/4	1/4, 3/8	1/4, 3/8



### Manifold

#### Valve

Normally closed (N.C.)  
Normally open (N.O.)  
Common (COM.)

#### Base

Common SUP/EXH type

#### Solenoid Coil

Coil: Class B, Class H

#### Rated Voltage

100 VAC, 200 VAC, 110 VAC,  
220 VAC, 240 VAC, 230 VAC,  
48 VAC, 24 VDC, 12 VDC

#### Material

Body — Brass  
Base — Aluminum  
Seal — NBR, FKM, EPDM

#### Electrical Entry

- Grommet
- Conduit
- DIN terminal
- Conduit terminal



Normally Closed (N.C.) /  
Normally Open (N.O.) /  
Common (COM.)

Model	VX31	VX32	VX33
Orifice size	1.5 mmø	●	—
	2.2 mmø	●	●
	3 mmø	●	●
	4 mmø	—	●
(Common SUP/EXH type) Port size	IN port	1/4	
	OUT port	1/8, 1/4	
	EXH port	1/4	

# Series VX31/32/33

## Standard Specifications

Valve specifications	Valve construction		Direct operated poppet
	Withstand pressure (MPa)		3.0
	Body material		Brass (C37), Stainless steel
	Seal material		NBR, FKM, EPDM, PTFE, FFKM
	Enclosure		Dust-tight, Low jetproof (equivalent to IP65)*
Environment		Location without corrosive or explosive gases	
Coil specifications	Rated voltage	AC (Class B coil, with full-wave rectifier)	100 VAC, 200 VAC, 110 VAC, 220 VAC, 230 VAC, 240 VAC, 48 VAC
		AC (Class H coil)	
		DC	
	Allowable voltage fluctuation		24 VDC, 12 VDC
			±10% of rated voltage
	Allowable leakage voltage	AC (Class B coil, with full-wave rectifier)	±5% or less of rated voltage
		AC (Class H coil)	±20% or less of rated voltage
DC		±2% or less of rated voltage	
Coil insulation type		Class B, Class H	

\* Electrical entry, Grommet with surge voltage suppressor (GS) has a rating of IP40.

## Solenoid Coil Specifications

### DC Specification

Model	Power consumption (W)	Temperature rise (C°) <sup>Note)</sup>
VX31	4.5	45
VX32	7	45
VX33	10.5	60

Note) The values are for an ambient temperature of 20°C and at the rated voltage.

### AC Specification (Class B coil, with full-wave rectifier)

Model	Apparent power (VA)*	Temperature rise (C°) <sup>Note)</sup>
VX31	7	55
VX32	9.5	60
VX33	12	65

\* There is no difference in the frequency and the inrush and energised apparent power, since a rectifying circuit is used in the AC (Class B) coil.

Note) The values are for an ambient temperature of 20°C and at the rated voltage.

### AC Specification (Class H coil)

Model	Frequency (Hz)	Apparent power (VA)		Temperature rise (C°) <sup>Note)</sup>
		Inrush	Energised	
VX31	50	33	14	65
	60	28	12	60
VX32	50	65	33	100
	60	55	27	95
VX33	50	94	50	120
	60	79	41	115

Note) The values are for an ambient temperature of 20°C and at the rated voltage.

### How to Order Solenoid Coil Assembly

#### DC Coil

VX02 **1**N-**5**G

Series	
1	VX31□□
2	VX32□□
3	VX33□□
Rated voltage Note 1)	
5	24 VDC
6	12 VDC

Note 1) Refer to Table (1) for the available combinations.

Electrical entry

<b>G</b> - Grommet <b>GS</b> - With grommet surge voltage suppressor	<b>C</b> - Conduit
<b>T</b> - With conduit terminal <b>TS</b> - With conduit terminal and surge voltage suppressor <b>TL</b> - With conduit terminal and light <b>TZ</b> - With conduit terminal, surge voltage suppressor and light	<b>D</b> - DIN <b>DS</b> - DIN with surge voltage suppressor <b>DL</b> - DIN with light <b>DZ</b> - DIN with surge voltage suppressor and light <b>DO</b> - For DIN (without connector)

\* Refer to Table (1) for the available combinations between each electrical option and rated voltage.

#### AC/Class B coil (with full-wave rectifier)

VX02 **1**N-**1**GR

Series		Rated voltage Note 1)	
1	VX31□□	1	100 VAC 50/60 Hz
2	VX32□□	2	200 VAC 50/60 Hz
3	VX33□□	3	110 VAC 50/60 Hz
		4	220 VAC 50/60 Hz
		7	240 VAC 50/60 Hz
		8	48 VAC 50/60 Hz
		J	230 VAC 50/60 Hz

Note 1) Refer to Table (1) for the available combinations.

Electrical entry

<b>G</b> - Grommet	<b>C</b> - Conduit
<b>T</b> - With conduit terminal <b>TL</b> - With conduit terminal and light	<b>D</b> - DIN <b>DL</b> - DIN with light <b>DO</b> - For DIN (without connector)

\* Refer to Table (1) for the available combinations between each electrical option and rated voltage.  
 \* Surge voltage suppressor is integrated into the AC/Class B coil as standard.

#### AC/Class H coil

VX02 **1**N-**1**G-H-Z

Series	
1	VX31□□
2	VX32□□
3	VX33□□
Rated voltage Note 1)	
1	100 VAC 50/60 Hz
2	200 VAC 50/60 Hz
3	110 VAC 50/60 Hz
4	220 VAC 50/60 Hz
7	240 VAC 50/60 Hz
8	48 VAC 50/60 Hz
J	230 VAC 50/60 Hz

Note 1) Refer to Table (1) for the available combinations.

Electrical entry

<b>G</b> - Grommet <b>GS</b> - With grommet surge voltage suppressor	<b>C</b> - Conduit
<b>T</b> - With conduit terminal <b>TS</b> - With conduit terminal and surge voltage suppressor <b>TL</b> - With conduit terminal and light <b>TZ</b> - With conduit terminal, surge voltage suppressor and light	

\* Refer to Table (1) for the available combinations between each electrical option and rated voltage.

#### Table (1) Rated Voltage – Electrical Option

Rated voltage			Class B			Class H		
AC/DC	Voltage symbol	Voltage	S With surge voltage suppressor	L With light	Z With light and surge voltage suppressor	S With surge voltage suppressor	L With light	Z With light and surge voltage suppressor
AC	1	100 V	Note 1)	●	Note 1)	●	●	●
	2	200 V		●		●		
	3	110 V		●		●		
	4	220 V		●		●		
	7	240 V		—		—		
	8	48 V		—		—		
DC	J	230 V	—	—	●	—	—	
	5	24 V	●	●	●	DC specification is not available.		
	6	12 V	●	—	—			

Note 1) Option S, Z are not available as a surge voltage suppressor is integrated into the AC/Class B coil as standard.  
 \* When changing coils, AC/DC are not interchangeable with each other, and Class B and H coils are also not interchangeable with each other.

#### • Name plate part no.

AZ-T-VX **Valve model**

↑ Enter by referring to "How to Order".

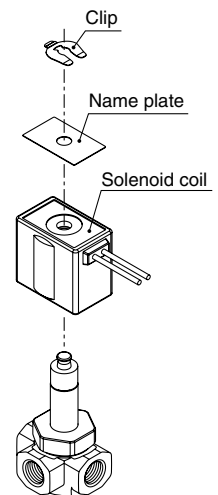

#### • Clip part no.

For VX31: VX021N-10  
 For VX32: VX022N-10  
 For VX33: VX023N-10

# Series VX31/32/33

## For Water /Single Unit

### Model/Valve Specifications

**N.C.**

Passage symbol

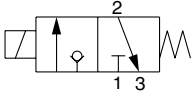

**N.O.**

Passage symbol

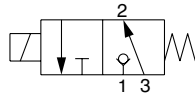

**COM.**

Passage symbol

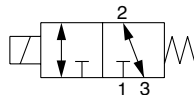

Port size	Orifice size (mmø)	Model	Max. operating pressure differential (MPa)			Flow characteristics		Max. system pressure (MPa)	Weight (g) <sup>Note)</sup>
			N.C.	N.O.	COM.	Av x 10 <sup>-6</sup> m <sup>2</sup>	Cv converted		
1/8 (6A)	1.5	VX311□-01	1	1	0.7	1.9	0.08	2.0	380
	2.2	VX312□-01	0.7	0.5	0.4	3.8	0.16		
	3	VX313□-01	0.3	0.3	0.2	5.8	0.24		
1/4 (8A)	1.5	VX311□-02	1	1	0.7	1.9	0.08		
		VX312□-02	0.7	0.5	0.4	3.8	0.16		
		VX322□-02	1.2	1	0.7	4.6	0.19		
	VX332□-02	1.6	1.6	1					
	3	VX313□-02	0.3	0.3	0.2	5.8	0.24		
		VX323□-02	0.6	0.5	0.3	7.9	0.33		
		VX333□-02	1	0.9	0.6				
	4	VX324□-02	0.3	0.25	0.2	12	0.50		
		VX334□-02	0.5	0.4	0.3				
VX322□-03		1.2	1	0.7					
3/8 (10A)	2.2	VX332□-03	1.6	1.6	1	4.6	0.19		
		VX323□-03	0.6	0.5	0.3	7.9	0.33		
	VX333□-03	1	0.9	0.6					
	3	VX324□-03	0.3	0.25	0.2	12	0.50		
		VX334□-03	0.5	0.4	0.3				
		VX322□-03	1.2	1	0.7				



Note) Weight of grommet type. Add 10 g for conduit, 30 g for DIN terminal, and 60 g for terminal type respectively.

Also, add 60 g for VX31□□, 80 g for VX32□□ and VX33□□ respectively for bracket option.

• Refer to "Glossary of Terms" on front matter 9, for details on the max. operating pressure differential and the max. system pressure.

### Operating Fluid and Ambient Temperature

Power source	Operating fluid temperature (°C)		Ambient temperature (°C)
	Solenoid valve option (symbol)		
	Standard, G, H	E, P	
DC/AC (Class B)	1 to 60	—	-20 to 60
AC (Class H)	—	1 to 99	-20 to 60



Note) With no freezing.

### Tightness of Valve (Leakage Rate)

Seal material	Max. operating pressure differential	Leakage rate (With water pressure)
NBR, FKM, EPDM	From 0 to less than 1 MPa	0.1 cm <sup>3</sup> /min or less
	1 MPa or more	0.2 cm <sup>3</sup> /min or less



# Direct Operated 3 Port Solenoid Valve Series VX31/32/33

For Water/Single Unit

## How to Order (Single Unit)

**DC, AC/Class H coil** VX 31 1 4 [ ] [ ] - 01 [ ] - 1 G 1 - [ ]

**AC/Class B coil (with full-wave rectifier)** VX 31 1 4 [ ] [ ] - 01 [ ] - 1 G R1 - [ ]

**Model** Refer to Table (1) shown below for availability.

**Orifice size** Refer to Table (1) shown below for availability.

**Valve/Body configuration**

0	N.C. / Single unit
2	N.O. / Single unit
4	COM. / Single unit

**Solenoid valve option** Refer to Table (2) shown below for availability.

**Port size** Refer to Table (1) shown below for availability.

**Thread type**

-	Rc
T	NPTF
F	G
N	NPT

**Suffix**

-	-
Z	Oil free

**Rated voltage**

1	100 VAC 50/60 Hz	6	12 VDC
2	200 VAC 50/60 Hz	7	240 VAC 50/60 Hz
3	110 VAC 50/60 Hz	8	48 VAC 50/60 Hz
4	220 VAC 50/60 Hz	J	230 VAC 50/60 Hz
5	24 VDC		

\* Refer to Table (3) shown below for availability.

Refer to page 3 for ordering coil only.

**Bracket**

-	None
B	With bracket

\* Bracket is not removable.

**With full-wave rectifier, surge voltage suppressor**

**Electrical entry**

**G** - Grommet  
**GS** - With grommet surge voltage suppressor

**C** - Conduit

**T** - With conduit terminal  
**TS** - With conduit terminal and surge voltage suppressor  
**TL** - With conduit terminal and light  
**TZ** - With conduit terminal, surge voltage suppressor and light

**D** - DIN  
**DS** - DIN with surge voltage suppressor  
**DL** - DIN with light  
**DZ** - DIN with surge voltage suppressor and light  
**DO** - For DIN (without connector)

\* DIN type is available with class B insulation only.

For Water

For Oil

For Steam

For Air

**Table (1) Port/Orifice Size**

Model	Solenoid valve			Orifice symbol (diameter)			
	VX31	VX32	VX33	1 (1.5 mmø)	2 (2.2 mmø)	3 (3 mmø)	4 (4 mmø)
Port no. (Port size)	01 (1/8)	-	-	●	●	●	-
	02 (1/4)	-	-	●	●	●	-
	-	02 (1/4)	02 (1/4)	-	●	●	●
	-	03 (3/8)	03 (3/8)	-	●	●	●

**Table (2) Solenoid Valve Option**

Option symbol	Seal material		Body material/ Shading coil material	Guide pin material	Coil insulation type	Note
	Main valve poppet	Fixed seals				
-	NBR	NBR	Brass (C37)	PPS	B	-
G	NBR	NBR	Stainless steel			
E	EPDM	EPDM	Brass (C37)/Copper	Stainless steel	H	Heated water
P	EPDM	EPDM	Stainless steel/Silver			
H	FKM	FKM	Stainless steel	PPS	B	-

**Table (3) Rated Voltage – Electrical Option**

AC/DC	Rated voltage		Class B		
	Voltage symbol	Voltage	S With surge voltage suppressor	L With light	Z With light and surge voltage suppressor
AC	1	100 V	●	●	-
	2	200 V	●	●	-
	3	110 V	●	●	-
	4	220 V	Note 1)	●	Note 1)
	7	240 V	-	-	-
	8	48 V	-	-	-
	J	230 V	-	-	-
DC	5	24 V	●	●	●
	6	12 V	●	-	-

Note 1) Option S, Z are not available as a surge voltage suppressor is integrated into the AC/Class B coil as standard.

AC/DC	Rated voltage		Class H		
	Voltage symbol	Voltage	S With surge voltage suppressor	L With light	Z With light and surge voltage suppressor
AC	1	100 V	●	●	●
	2	200 V	●	●	●
	3	110 V	●	●	●
	4	220 V	●	●	●
	7	240 V	●	-	-
	8	48 V	●	-	-
	J	230 V	●	-	-
DC	5	24 V	DC specification is not available.		
	6	12 V	DC specification is not available.		

# Series VX31/32/33

## For Oil /Single Unit

### Model/Valve Specifications

**N.C.**

Passage symbol

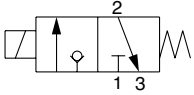

**N.O.**

Passage symbol

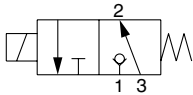

**COM.**

Passage symbol

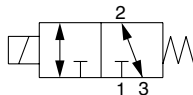

Port size	Orifice size (mmø)	Model	Max. operating pressure differential (MPa)			Flow characteristics		Max. system pressure (MPa)	Weight (g) <sup>Note)</sup>
			N.C.	N.O.	COM.	Av x 10 <sup>-6</sup> m <sup>2</sup>	Cv converted		
1/8 (6A)	1.5	VX311□-01	1	1	0.7	1.9	0.08	2.0	380
	2.2	VX312□-01	0.7	0.5	0.4	3.8	0.16		
	3	VX313□-01	0.3	0.3	0.2	5.8	0.24		
1/4 (8A)	1.5	VX311□-02	1	1	0.7	1.9	0.08		
		VX312□-02	0.7	0.5	0.4	3.8	0.16		
		VX322□-02	1.2	1	0.7	4.6	0.19		
	2.2	VX332□-02	1.6	1.6	1	4.6	0.19		530
		VX313□-02	0.3	0.3	0.2				5.8
		VX323□-02	0.6	0.5	0.3	7.9	0.33		380
		VX333□-02	1	0.9	0.6				530
		VX324□-02	0.3	0.25	0.2				530
3	VX334□-02	0.5	0.4	0.3	12	0.50	730		
	VX324□-02	0.3	0.25	0.2	12	0.50	530		
3/8 (10A)	2.2	VX322□-03	1.2	1			0.7	4.6	0.19
		VX332□-03	1.6	1.6	1	4.6	0.19		
	3	VX323□-03	0.6	0.5	0.3	7.9	0.33	530	
		VX333□-03	1	0.9	0.6			730	
		VX324□-03	0.3	0.25	0.2			530	
	4	VX334□-03	0.5	0.4	0.3	12	0.50	730	
		VX324□-03	0.3	0.25	0.2	12	0.50	530	



Note) Weight of grommet type. Add 10 g for conduit, 30 g for DIN terminal, and 60 g for terminal type respectively.

Also, add 60 g for VX31□□, 80 g for VX32□□ and VX33□□ respectively for bracket option.

• Refer to "Glossary of Terms" on front matter 9, for details on the max. operating pressure differential and the max. system pressure.

### Operating Fluid and Ambient Temperature

Power source	Operating fluid temperature (°C)		Ambient temperature (°C)
	Solenoid valve option (symbol)		
	A, H	D, N	
DC/AC (Class B)	-5 <sup>Note)</sup> to 60	—	-20 to 60
AC (Class H)	—	-5 <sup>Note)</sup> to 120	-20 to 60



Note) Kinematic viscosity: 50 mm<sup>2</sup>/s or less.

### Tightness of Valve (Leakage Rate)

Seal material	Max. operating pressure differential	Leakage rate (With oil pressure)
FKM	From 0 to less than 1 MPa	0.1 cm <sup>3</sup> /min or less
	1 MPa or more	0.2 cm <sup>3</sup> /min or less

## How to Order (Single Unit)

**DC, AC/Class H coil**

**AC/Class B coil (with full-wave rectifier)**

**VX 31 1 4 A [ ] 01 [ ] 1 G 1 [ ]**

**VX 31 1 4 A [ ] 01 [ ] 1 G R1 [ ]**

**Bracket**

-	None
B	With bracket

\* Bracket is not removable.

**Model** • Refer to Table (1) shown below for availability.

**Orifice size** • Refer to Table (1) shown below for availability.

**Valve/Body configuration** •

0	N.C. / Single unit
2	N.O. / Single unit
4	COM. / Single unit

**Solenoid valve option** • Refer to Table (2) shown below for availability.

**Port size** • Refer to Table (1) shown below for availability.

**Thread type** •

-	Rc
T	NPTF
F	G
N	NPT

**Suffix** •

-	-
Z	Oil free

**Rated voltage** •

1	100 VAC 50/60 Hz	6	12 VDC
2	200 VAC 50/60 Hz	7	240 VAC 50/60 Hz
3	110 VAC 50/60 Hz	8	48 VAC 50/60 Hz
4	220 VAC 50/60 Hz	J	230 VAC 50/60 Hz
5	24 VDC		

\* Refer to Table (3) shown below for availability.

Refer to page 3 for ordering coil only.

**Electrical entry** •

<b>G</b> - Grommet <b>GS</b> - With grommet surge voltage suppressor	<b>C</b> - Conduit
<b>T</b> - With conduit terminal <b>TS</b> - With conduit terminal and surge voltage suppressor <b>TL</b> - With conduit terminal and light <b>TZ</b> - With conduit terminal, surge voltage suppressor and light	<b>D</b> - DIN <b>DS</b> - DIN with surge voltage suppressor <b>DL</b> - DIN with light <b>DZ</b> - DIN with surge voltage suppressor and light <b>DO</b> - For DIN (without connector)

\* Refer to Table (3) for the available combinations between each electrical option (S, L, Z) and rated voltage.  
\* Surge voltage suppressor is integrated into the AC/Class B coil as standard.

For Water

For Oil

For Steam

For Air

**Table (1) Port/Orifice Size**

Solenoid valve		Orifice symbol (diameter)					
		1 (1.5 mmø)	2 (2.2 mmø)	3 (3 mmø)	4 (4 mmø)		
Model	VX31	VX32	VX33				
Port no. (Port size)	01 (1/8)	-	-	●	●	●	-
	02 (1/4)	-	-	●	●	●	-
	-	02 (1/4)	02 (1/4)	-	●	●	●
	-	03 (3/8)	03 (3/8)	-	●	●	●

**Table (2) Solenoid Valve Option**

Option symbol	Seal material		Body material/ Shading coil material	Guide pin material	Coil insulation type
	Main valve poppet	Fixed seals			
<b>A</b>	FKM	FKM	Brass (C37)	PPS	B
<b>H</b>			Stainless steel		
<b>D</b>			Brass (C37)/Copper	Stainless steel	H
<b>N</b>			Stainless steel/Silver		

\* The additives contained in oil are different depending on the type and manufacturers, so the durability of the seal materials will vary. For details, please consult with SMC.

**Table (3) Rated Voltage – Electrical Option**

Rated voltage			Class B		
AC/DC	Voltage symbol	Voltage	S With surge voltage suppressor	L With light	Z With light and surge voltage suppressor
AC	1	100 V	●	●	●
	2	200 V	●	●	●
	3	110 V	●	●	●
	4	220 V	Note 1)	●	Note 1)
	7	240 V	●	-	-
	8	48 V	●	-	-
DC	J	230 V	●	-	-
	5	24 V	●	●	●
	6	12 V	●	-	-

Note 1) Option S, Z are not available as a surge voltage suppressor is integrated into the AC/Class B coil as standard.

Rated voltage			Class H		
AC/DC	Voltage symbol	Voltage	S With surge voltage suppressor	L With light	Z With light and surge voltage suppressor
AC	1	100 V	●	●	●
	2	200 V	●	●	●
	3	110 V	●	●	●
	4	220 V	●	●	●
	7	240 V	●	-	-
	8	48 V	●	-	-
DC	J	230 V	●	-	-
	5	24 V	DC specification is not available.		
	6	12 V	DC specification is not available.		

# Series VVX31/32/33

## For Oil/Manifold

### Solenoid Valve for Manifold/Valve Specifications

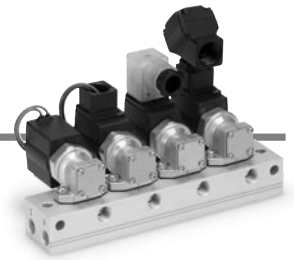

N.C.

N.O.

COM.

Passage symbol

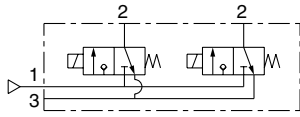

Passage symbol

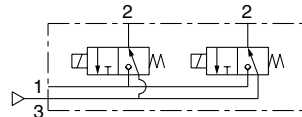

Passage symbol

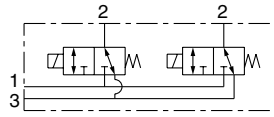

Orifice size (mmø)	Model	Max. operating pressure differential (MPa)			Flow characteristics		Max. system pressure (MPa)
		N.C.	N.O.	COM.	Av x 10 <sup>-6</sup> m <sup>2</sup>	Cv converted	
1.5	VX311□-00	1	1	0.7	1.9	0.08	2.0
2.2	VX312□-00	0.7	0.5	0.4	3.8	0.16	
	VX322□-00	1.2	1	0.7	4.6	0.19	
	VX332□-00	1.6	1.6	1			
3	VX313□-00	0.3	0.3	0.2	5.8	0.24	
	VX323□-00	0.6	0.5	0.3	7.9	0.33	
	VX333□-00	1	0.9	0.6			
4	VX324□-00	0.3	0.25	0.2	12	0.50	
	VX334□-00	0.5	0.4	0.3			



• Refer to "Glossary of Terms" on front matter 9 for details on the max. operating pressure differential and the max. system pressure.

### Operating Fluid and Ambient Temperature

Power source	Operating fluid temperature (°C)		Ambient temperature (°C)
	Solenoid valve option (symbol)		
	A	D	
DC/AC (Class B)	-5 <sup>Note)</sup> to 60	—	-20 to 60
AC (Class H)	—	-5 <sup>Note)</sup> to 120	-20 to 60



Note) kinematic viscosity: 50 mm<sup>2</sup>/s or less.

### Tightness of Valve (Leakage Rate)

Seal material	Max. operating pressure differential	Leakage rate (With oil pressure)
FKM	From 0 to less than 1 MPa	0.1 cm <sup>3</sup> /min or less
	1 MPa or more	0.2 cm <sup>3</sup> /min or less

## How to Order (Solenoid Valve for Manifold)

**DC, AC/Class H coil** VX 31 1 1 A □ — 00 — 1 G 1

**AC/Class B coil (with full-wave rectifier)** VX 31 1 1 A □ — 00 — 1 G R1

**Model** Refer to Table (1) shown below for availability.

**Orifice size** Refer to Table (1) shown below for availability.

**Valve/Body configuration**

1	N.C. / Manifold
3	N.O. / Manifold
5	COM. / Manifold

**Solenoid valve option** Refer to Table (2) shown below for availability.

**Rated voltage**

1	100 VAC 50/60 Hz	6	12 VDC
2	200 VAC 50/60 Hz	7	240 VAC 50/60 Hz
3	110 VAC 50/60 Hz	8	48 VAC 50/60 Hz
4	220 VAC 50/60 Hz	J	230 VAC 50/60 Hz
5	24 VDC		

\* Refer to Table (3) shown below for availability.

**Suffix**

-	—
Z	Oil free

**Electrical entry**

**G** - Grommet  
**GS** - With grommet surge voltage suppressor

**C** - Conduit

**D** - DIN  
**DS** - DIN with surge voltage suppressor  
**DL** - DIN with light  
**DZ** - DIN with surge voltage suppressor and light  
**DO** - For DIN (without connector)

**T** - With conduit terminal  
**TS** - With conduit terminal and surge voltage suppressor  
**TL** - With conduit terminal and light  
**TZ** - With conduit terminal, surge voltage suppressor and light

\* DIN type is available with class B insulation only.

\* Refer to Table (3) for the available combinations between each electrical option (S, L, Z) and rated voltage.  
 \* Surge voltage suppressor is integrated into the AC/Class B coil as standard.

For Water  
 For Oil  
 For Steam  
 For Air

## How to Order Manifold Bases

VVX31  
 VVX32  
 VVX33

1 □ — 07 — 1

**Manifold base**

**Suffix**

-	—
Z	Oil free

**Number of manifolds**

02	2 stations
•	•
•	•
•	•
10	10 stations

**Port size (Individual port)**

1	Rc1/8
2	Rc1/4

\* Common port sizes are all Rc1/4.  
 \* Indicating numbers shown below are for common ports.

Type	SUP port	EXH port
N.C.	1	3
N.O.	3	1

### Blanking plate part no.

For VX31: VVX31-4A-F

For VX32/33: VVX32-4A-F

Seal material: FKM

## How to Order Manifold Assemblies (Example)

Enter the valve and blanking plate to be mounted under the manifold base part number.

Example  
 VVX3111-05-1 ..... 1 set  
 \* VX3111A-00-1GR1 .. 4 sets  
 \* VVX31-4A-F..... 1 set

\* "—" is the symbol for mounting.  
 Add an "—" in front of the part numbers for solenoid valves, etc. to be mounted.

Enter the product's part number in order, counting from the 1st station on the left in the manifold arrangement, when viewed from the individual ports in front. The common ports on the right side are plugged.

Table (1) Port/Orifice Size

Solenoid valve	Orifice symbol (diameter)			
	1 (1.5 mmø)	2 (2.2 mmø)	3 (3 mmø)	4 (4 mmø)
VX31	●	●	●	—
VX32	—	●	●	●
VX33	—	●	●	●

Table (2) Solenoid Valve Option

Option symbol	Seal material		Body material/ Shading coil material	Guide pin material	Coil insulation type
	Main valve poppet	Fixed seals			
A	FKM	FKM	Brass (C37)	PPS	B
D	FKM	FKM	Brass (C37)/Copper	Stainless steel	H

\* Aluminum is the only available material for the manifold base.

The additives contained in oil are different depending on the type and manufacturers, so the durability of the seal materials will vary. For details, please consult with SMC.

Table (3) Rated Voltage – Electrical Entry – Electrical Option

AC/DC	Rated voltage		Class B			Class H		
	Voltage symbol	Voltage	S With surge voltage suppressor	L With light	Z With light and surge voltage suppressor	S With surge voltage suppressor	L With light	Z With light and surge voltage suppressor
AC	1	100 V	●	●	●	●	●	●
	2	200 V	●	●	●	●	●	●
	3	110 V	●	●	●	●	●	●
	4	220 V	●	●	●	●	●	●
	7	240 V	—	—	—	●	—	—
	8	48 V	—	—	—	●	—	—
DC	J	230 V	—	—	—	●	—	—
	5	24 V	●	●	●	DC specification is not available.		
	6	12 V	●	—	—	DC specification is not available.		

Note 1) Option S, Z are not available as a surge voltage suppressor is integrated into the AC/Class B coil as standard.

# Series VX31/32/33

## For Steam /Single Unit

### Model/Valve Specifications

COM.

Passage symbol

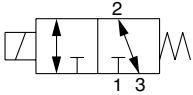

Port size	Orifice size (mmø)	Model	Max. operating pressure differential (MPa)	Flow characteristics		Max. system pressure (MPa)	Weight (g) <sup>Note)</sup>
			COM.	Av x 10 <sup>-6</sup> m <sup>2</sup>	Cv converted		
1/8 (6A)	1.5	VX3114-01	0.7	1.9	0.08	1.0	380
	2.2	VX3124-01	0.4	3.8	0.16		
	3	VX3134-01	0.2	5.8	0.24		
1/4 (8A)	1.5	VX3114-02	0.7	1.9	0.08		
		VX3124-02	0.4	3.8	0.16		
		VX3224-02	0.7	4.6	0.19		
	VX3324-02	1					
	3	VX3134-02	0.2	5.8	0.24		
		VX3234-02	0.3	7.9	0.33		
		VX3334-02	0.6				
	4	VX3244-02	0.2	12	0.50		
VX3344-02		0.3					
3/8 (10A)	2.2	VX3224-03	0.7	4.6	0.19	530	
		VX3324-03	1			730	
	3	VX3234-03	0.3	7.9	0.33	530	
		VX3334-03	0.6			730	
	4	VX3244-03	0.2	12	0.50	530	
		VX3344-03	0.3			730	



Note) Weight of grommet type. Add 10 g for conduit, 30 g for DIN terminal, and 60 g for terminal type respectively.

Also, add 60 g for VX31□□, 80 g for VX32□□ and VX33□□ respectively for bracket option.

• Refer to "Glossary of Terms" on front matter 9, for details on the max. operating pressure differential and the max. system pressure.

### Operating Fluid and Ambient Temperature

Power source	Operating fluid temperature (°C)	Ambient temperature (°C)
	Solenoid valve option (symbol) S, Q	
AC	183	-20 to 60

### Tightness of Valve (Leakage Rate)

Seal material		Leakage rate (With air pressure)
Main valve poppet	Fixed seals	
FFKM	PTFE	150 cm <sup>3</sup> /min or less

## How to Order (Single Unit)

**VX** 31 1 4 S   01   1 G 1

**Model**  
Refer to Table (1) shown below for availability.

**Orifice size**  
Refer to Table (1) shown below for availability.

**Valve/Body configuration**  

4	COM. / Single unit
---	--------------------

**Solenoid valve option**  
Refer to Table (2) shown below for availability.

**Port size**  
Refer to Table (1) shown below for availability.

**Thread type**  

-	Rc
T	NPTF
F	G
N	NPT

**Rated voltage**  

1	100 VAC 50/60 Hz	7	240 VAC 50/60 Hz
2	200 VAC 50/60 Hz	8	48 VAC 50/60 Hz
3	110 VAC 50/60 Hz	J	230 VAC 50/60 Hz
4	220 VAC 50/60 Hz		

**Suffix**  

-	-
Z	Oil free

**Bracket**  

-	None
B	With bracket

  
\* Bracket is not removable.

**Electrical entry**  

G - Grommet		C-Conduit	
GS-With grommet surge voltage suppressor		T -With conduit terminal	
T -With conduit terminal		TS -With conduit terminal and surge voltage suppressor	
TL -With conduit terminal and light		TZ -With conduit terminal, surge voltage suppressor and light	
TZ -With conduit terminal, surge voltage suppressor and light			

\* Refer to Table (3) shown below for availability.

Refer to page 3 for ordering coil only.

For Water

For Oil

For Steam

For Air

**Table (1) Port/Orifice Size**

Solenoid valve		Orifice symbol (diameter)					
		1 (1.5 mmø)	2 (2.2 mmø)	3 (3 mmø)	4 (4 mmø)		
Model	VX31	VX32	VX33	●	●	●	—
	01 (1/8)	—	—	●	●	●	—
	02 (1/4)	—	—	●	●	●	—
	—	02 (1/4)	02 (1/4)	—	●	●	●
Port no. (Port size)	—	03 (3/8)	03 (3/8)	—	●	●	●
	—	—	—	—	●	●	●

**Table (2) Solenoid Valve Option**

Option symbol	Seal material		Body material/ Shading coil material	Guide pin material	Coil insulation type
	Main valve poppet	Fixed sealant			
<b>S</b>	FFKM	PTFE	Brass (C37)/Copper	Stainless steel	H
<b>Q</b>	FFKM	PTFE	Stainless steel/Silver	Stainless steel	H

Solenoid coil: AC/Class H only

**Table (3) Rated Voltage – Electrical Option**

Rated voltage			Class H		
AC/DC	Voltage symbol	Voltage	S With surge voltage suppressor	L With light	Z With light and surge voltage suppressor
AC	1	100 V	●	●	●
	2	200 V	●	●	●
	3	110 V	●	●	●
	4	220 V	●	●	●
	7	240 V	●	—	—
	8	48 V	●	—	—
DC	J	230 V	●	—	—
	5	24 V	DC specification is not available.		
	6	12 V	DC specification is not available.		

# Series VX31/32/33

## For Air /Single Unit

(Inert gas, Non-leak, Medium vacuum)

### Model/Valve Specifications

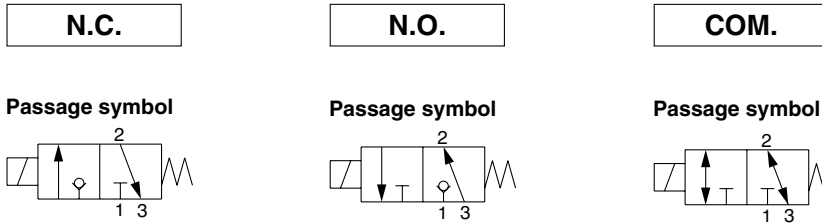

Port size	Orifice size (mmø)	Model	Max. operating pressure differential (MPa)			Flow characteristics			Max. system pressure (MPa)	Weight (g) <sup>Note)</sup>
			N.C.	N.O.	COM.	C[dm <sup>3</sup> /(s·bar)]	b	Cv		
1/8 (6A)	1.5	VX311□-01	1	1	0.7	0.29	0.32	0.08	2.0	380
	2.2	VX312□-01	0.7	0.5	0.4	0.60	0.25	0.15		
	3	VX313□-01	0.3	0.3	0.2	0.82	0.20	0.20		
1/4 (8A)	1.5	VX311□-02	1	1	0.7	0.29	0.32	0.08		
		VX312□-02	0.7	0.5	0.4	0.60	0.25	0.15		
	2.2	VX322□-02	1.2	1	0.7	0.64	0.40	0.17		
		VX332□-02	1.6	1.6	1					
		VX313□-02	0.3	0.3	0.2	0.82	0.20	0.20		
	3	VX323□-02	0.6	0.5	0.3	1.1	0.25	0.27		
		VX333□-02	1	0.9	0.6					
		VX324□-02	0.3	0.25	0.2					
4	VX334□-02	0.5	0.4	0.3	1.6	0.20	0.38			
	VX324□-02	0.3	0.25	0.2						
3/8 (10A)	2.2	VX322□-03	1.2	1	0.7	0.64	0.40	0.17		
		VX332□-03	1.6	1.6	1					
	3	VX323□-03	0.6	0.5	0.3	1.1	0.25	0.27		
		VX333□-03	1	0.9	0.6					
		VX324□-03	0.3	0.25	0.2					
	4	VX334□-03	0.5	0.4	0.3	1.6	0.20	0.38		
		VX324□-03	0.3	0.25	0.2					

Note) Weight of grommet type. Add 10 g for conduit, 30 g for DIN terminal, and 60 g for terminal type respectively.

Also, add 60 g for VX31□□, 80 g for VX32□□ and VX33□□ respectively for bracket option.

• Refer to "Glossary of Terms" on front matter 9, for details on the max. operating pressure differential and the max. system pressure.

### Operating Fluid and Ambient Temperature

Power source	Operating fluid temperature (°C)		Ambient temperature (°C)
	Solenoid valve option (symbol)		
	Standard, G	V, M	
AC (Class B), DC	-10 <sup>Note)</sup> to 60	-10 <sup>Note)</sup> to 60	-20 to 60

Note) Dew point temperature: -10°C or less

### Tightness of Valve (Leakage Rate)

Seal material	Max. operating pressure differential	Leakage rate	
		Air	<sup>Note)</sup> Non-leak, Medium vacuum
NBR, FKM	From 0 to less than 1 MPa	1 cm <sup>3</sup> /min or less	10 <sup>-6</sup> Pa·m <sup>3</sup> /sec or less
	1 MPa or more	2 cm <sup>3</sup> /min or less	

Note) The leakage amount (10<sup>-6</sup> Pa·m<sup>3</sup>/sec) for the "V" and "M" option are values when the differential pressure is 0.1 MPa.



## How to Order (Single Unit)

**DC**

**AC/Class B coil (with full-wave rectifier)**

**VX 31 1 4 [ ] [ ] 01 [ ] 5 G 1 [ ]**

**VX 31 1 4 [ ] [ ] 01 [ ] 1 GR1 [ ]**

**Bracket**

-	None
B	With bracket

\* Bracket is not removable.

**Model** • Refer to Table (1) shown below for availability.

**Orifice size** • Refer to Table (1) shown below for availability.

**Valve/Body configuration**

0	N.C. / Single unit
2	N.O. / Single unit
4	COM. / Single unit

**Solenoid valve option** • Refer to Table (2) shown below for availability.

**Port size** • Refer to Table (1) shown below for availability.

**Suffix**

-	—
Z	Oil free

**Thread type**

-	Rc
T	NPTF
F	G
N	NPT

**Rated voltage**

1	100 VAC 50/60 Hz	6	12 VDC
2	200 VAC 50/60 Hz	7	240 VAC 50/60 Hz
3	110 VAC 50/60 Hz	8	48 VAC 50/60 Hz
4	220 VAC 50/60 Hz	J	230 VAC 50/60 Hz
5	24 VDC		

\* Refer to Table (3) shown below for availability.

Refer to page 3 for ordering coil only.

**Electrical entry (AC/DC)**

<b>G</b> - Grommet		<b>C</b> - Conduit	
<b>GS</b> - With grommet surge voltage suppressor			
<b>T</b> - With conduit terminal		<b>D</b> - DIN	
<b>TS</b> - With conduit terminal and surge voltage suppressor		<b>DS</b> - DIN with surge voltage suppressor	
<b>TL</b> - With conduit terminal and light		<b>DL</b> - DIN with light	
<b>TZ</b> - With conduit terminal, surge voltage suppressor and light		<b>DZ</b> - DIN with surge voltage suppressor and light	
		<b>DO</b> - For DIN (without connector)	

\* DIN type is available with class B insulation only.

\* Refer to Table (3) for the available combinations between each electrical option (S, L, Z) and rated voltage.

\* Surge voltage suppressor is integrated into the AC/Class B coil as standard.

For Water

For Oil

For Steam

For Air

**Table (1) Port/Orifice Size**

Solenoid valve			Orifice symbol (diameter)				
Model	VX31	VX32	VX33	1 (1.5 mmø)	2 (2.2 mmø)	3 (3 mmø)	4 (4 mmø)
Port no. (Port size)	01 (1/8)	—	—	●	●	●	—
	02 (1/4)	—	—	●	●	●	—
	—	02 (1/4)	02 (1/4)	—	●	●	●
	—	03 (3/8)	03 (3/8)	—	●	●	●

**Table (2) Solenoid Valve Option**

Option symbol	Seal material		Body material/ Shading coil material	Guide pin material	Coil insulation type	Note <sup>Note)</sup>
	Main valve poppet	Fixed seals				
-			Brass (C37)			—
G	NBR	NBR	Stainless steel	PPS	B	Non-leak (10 <sup>-6</sup> Pa·m <sup>3</sup> /sec), Medium vacuum (0.1 Pa.abs)
M	FKM	FKM	Stainless steel			
V	FKM	FKM	Brass (C37)			

Note) The leakage amount (10<sup>-6</sup> Pa·m<sup>3</sup>/sec) for the "V" and "M" option are values when the differential pressure is 0.1 MPa.

**Table (3) Rated Voltage – Electrical Option**

Rated voltage		Class B			
AC/DC	Voltage symbol	Voltage	S With surge voltage suppressor	L With light	Z With light and surge voltage suppressor
AC	1	100 V		●	
	2	200 V		●	
	3	110 V	Note 1)	●	Note 1)
	4	220 V		●	
	7	240 V		—	
	8	48 V		—	
DC	J	230 V		—	
	5	24 V	●	●	●
	6	12 V	●	—	—

Note 1) Option S, Z are not available as a surge voltage suppressor is integrated into the AC/Class B coil as standard.

\* Class H coil is not available.

# Series VVX31/32/33

## For Air/Manifold

(Inert gas, Non-leak, Medium vacuum)

### Solenoid Valve for Manifold/Valve Specifications

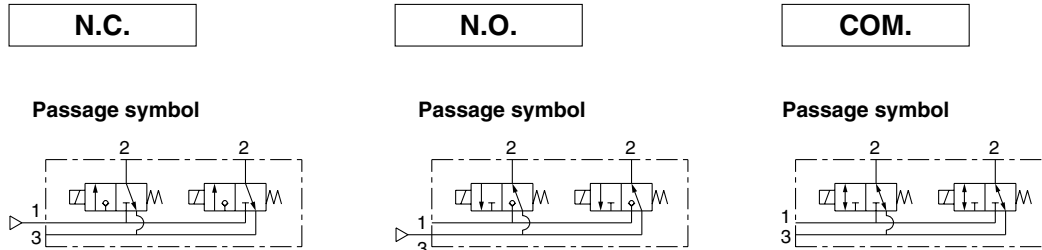

Orifice size (mmø)	Model	Max. operating pressure differential (MPa)			Flow characteristics			Max. system pressure (MPa)
		N.C.	N.O.	COM.	C[dm <sup>3</sup> /(s·bar)]	b	Cv	
1.5	VX311□-00	1	1	0.7	0.29	0.32	0.08	2.0
2.2	VX312□-00	0.7	0.5	0.4	0.60	0.25	0.15	
	VX322□-00	1.2	1	0.7	0.64	0.40	0.20	
VX332□-00	1.6	1.6	1					
3	VX313□-00	0.3	0.3	0.2	0.82	0.20	0.17	
	VX323□-00	0.6	0.5	0.3	1.1	0.25	0.27	
VX333□-00	1	0.9	0.6					
4	VX324□-00	0.3	0.25	0.2	1.6	0.20	0.38	
	VX334□-00	0.5	0.4	0.3				



• Refer to "Glossary of Terms" on front matter 9 for details on the max. operating pressure differential and the max. system pressure.

### Operating Fluid and Ambient Temperature

Power source	Operating fluid temperature (°C)		Ambient temperature (°C)
	Solenoid valve option (symbol)		
AC (Class B), DC	Standard	-10 <sup>Note)</sup> to 60	-20 to 60
	V	-10 <sup>Note)</sup> to 60	



Note) Dew point temperature: -10°C or less

### Tightness of Valve (Leakage Rate)

Seal material	Max. operating pressure differential	Leakage rate	
		Air	<sup>Note)</sup> Non-leak, Medium vacuum
NBR, FKM	From 0 to less than 1 MPa	1 cm <sup>3</sup> /min or less	10 <sup>-6</sup> Pa·m <sup>3</sup> /sec or less
	1 MPa or more	2 cm <sup>3</sup> /min or less	



Note) The leakage amount (10<sup>-6</sup> Pa·m<sup>3</sup>/sec) for the "V" option is a value when the differential pressure is 0.1 MPa.

## How to Order (Solenoid Valve for Manifold)

**DC**  
**AC/Class B coil (with full-wave rectifier)**

**Model** Refer to Table (1) shown below for availability.

**Orifice size** Refer to Table (1) shown below for availability.

**Suffix**

-	—
Z	Oil free

**Valve/Body configuration**

1	N.C. / Manifold
3	N.O. / Manifold
5	COM. / Manifold

**Solenoid valve option** Refer to Table (2) shown below for availability.

**Rated voltage**

1	100 VAC 50/60 Hz	6	12 VDC
2	200 VAC 50/60 Hz	7	240 VAC 50/60 Hz
3	110 VAC 50/60 Hz	8	48 VAC 50/60 Hz
4	220 VAC 50/60 Hz	J	230 VAC 50/60 Hz
5	24 VDC		

\* Refer to Table (3) shown below for availability.

Refer to page 3 for ordering coil only.

**Electrical entry (AC/DC)**

**G - Grommet**  
**GS - With grommet surge voltage suppressor**

**C - Conduit**

**T - With conduit terminal**  
**TS - With conduit terminal and surge voltage suppressor**  
**TL - With conduit terminal and light**  
**TZ - With conduit terminal, surge voltage suppressor and light**

**D - DIN**  
**DS - DIN with surge voltage suppressor**  
**DL - DIN with light**  
**DZ - DIN with surge voltage suppressor and light**  
**DO - For DIN (without connector)**

\* DIN type is available with class B insulation only.

For Water

For Oil

For Steam

For Air

## How to Order Manifold Bases

**VVX31**  
**VVX32**  
**VVX33**

**Number of manifolds**

02	2 stations
•	•
•	•
•	•
10	10 stations

**Port size (Individual port)**

1	Rc1/8
2	Rc1/4

\* Common port sizes are all Rc1/4.  
 \* Indicating numbers shown below are for common

Type	SUP port	EXH port
N.C.	1	3
N.O.	3	1

**Suffix**

-	—
Z	Oil free

**Manifold base**

**Blanking plate part no.**

For VX31: VVX31-4A-  
 For VX32/33: VVX32-4A-

**Seal material**

-	NBR
F	FKM

## How to Order Manifold Assemblies (Example)

Enter the valve and blanking plate to be mounted under the manifold base part number.

Example  
 VVX311-05-1 ..... 1 set    "\*" is the symbol for mounting.  
 \* VX3111-00-1GR1 ... 4 sets    Add an "\*" in front of the part numbers for solenoid valves, etc. to be mounted.  
 \* VVX31-4A ..... 1 set

Enter the product's part number in order, counting from the 1st station on the left in the manifold arrangement, when viewed from the individual ports in front. The common ports on the right side are plugged.

Table (1) Port/Orifice Size

Solenoid valve	Orifice symbol (diameter)			
	1 (1.5 mmø)	2 (2.2 mmø)	3 (3 mmø)	4 (4 mmø)
VX31	●	●	●	—
VX32	—	●	●	●
VX33	—	●	●	●

Table (2) Solenoid Valve Option

Option symbol	Seal material		Body material	Guide pin material	Coil insulation type	Note <sup>Note)</sup>
	Main valve poppet	Fixed seals				
-	NBR	NBR	Brass (C37)	PPS	B	Non-leak (10 <sup>-6</sup> Pa·m <sup>3</sup> /sec), Medium vacuum (0.1 Pa.abs)
V	FKM	FKM				

\* Aluminum is the only available material for the manifold base.

Note) The leakage amount (10<sup>-8</sup> Pa·m<sup>3</sup>/sec) for the "V" and "M" option are values when the differential pressure is 0.1 MPa.

Table (3) Rated Voltage – Electrical Option

Rated voltage	Class B		
	S	L	Z
AC	1 100 V	●	Note 1)
	2 200 V	●	
	3 110 V	●	
	4 220 V	●	
	7 240 V	—	
	8 48 V	—	
DC	J 230 V	—	Note 1)
	5 24 V	●	
	6 12 V	●	

\* Class H coil is not available.

Note 1) Option S, Z are not available as a surge voltage suppressor is integrated into the AC/Class B coil as standard.

# Series VX31/32/33

For Water, Oil, Steam, Air

## Construction

### Single unit

Body material: Brass, Stainless Steel

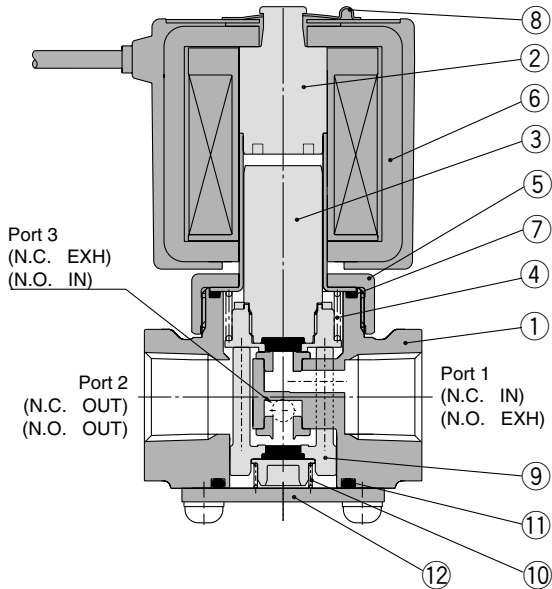

### Component Parts

No.	Description	Material	
		Standard	Option
1	<b>Body</b>	Brass	Stainless steel
2	<b>Tube assembly</b>	Stainless steel, Copper	Stainless steel, Silver
3	<b>Armature assembly</b>	Stainless steel, Brass, PTFE (NBR)	Stainless steel, PTFE (FKM, EPDM, FFKM)
4	<b>Return spring</b>	Stainless steel	
5	<b>Nut</b>	Brass	Brass • Ni plated
6	<b>Solenoid coil</b>	Class B molded	Class H molded
7	<b>O-ring</b>	(NBR)	(FKM, EPDM, PTFE)
8	<b>Clip</b>	SK	
9	<b>Guide pin assembly</b>	PPS, Brass, (NBR)	Stainless steel (FKM, EPDM, FFKM)
10	<b>Support spring</b>	Stainless steel	
11	<b>O-ring</b>	(NBR)	(FKM, EPDM, PTFE)
12	<b>Plate</b>	Stainless steel	

The materials in parentheses are the seal materials.

### Manifold

Base material: Aluminum

Manifold body material: Brass

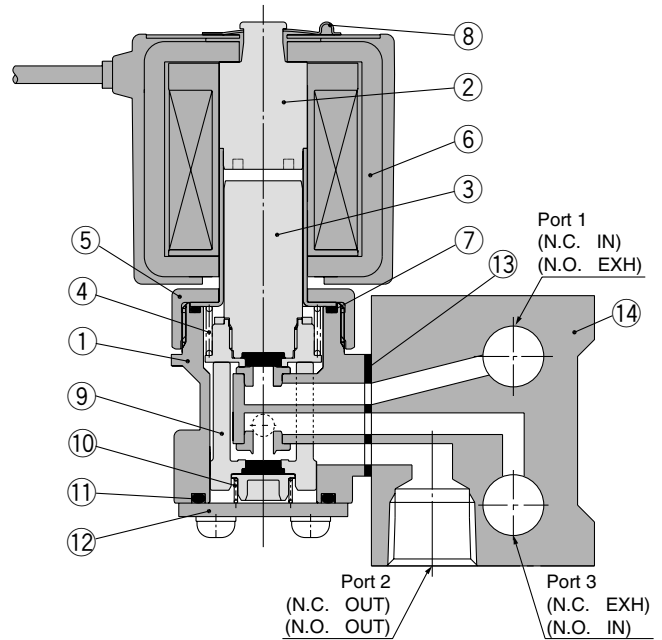

### Component Parts

No.	Description	Material	
		Standard	Option
1	<b>Manifold body</b>	Brass	
2	<b>Tube assembly</b>	Stainless steel, Copper	
3	<b>Armature assembly</b>	Stainless steel, Brass, PTFE (NBR)	Stainless steel, PTFE (FKM, EPDM, FFKM)
4	<b>Return spring</b>	Stainless steel	
5	<b>Nut</b>	Brass	Brass • Ni plated
6	<b>Solenoid coil</b>	Class B molded	Class H molded
7	<b>O-ring</b>	(NBR)	(FKM, EPDM)
8	<b>Clip</b>	SK	
9	<b>Guide pin assembly</b>	PPS, Brass, (NBR)	Stainless steel (FKM, EPDM)
10	<b>Support spring</b>	Stainless steel	
11	<b>O-ring</b>	(NBR)	(FKM, EPDM)
12	<b>Plate</b>	Stainless steel	
13	<b>Gasket</b>	(NBR)	(FKM, EPDM)
14	<b>Base</b>	Aluminum	

The materials in parentheses are the seal materials.

**Dimensions: Single Unit/Body Material: Brass (C37), Stainless Steel**

Normally closed (N.C.): VX31□0/VX32□0/VX33□0

Normally open (N.O.): VX31□2/VX32□2/VX33□2

Common (COM.): VX31□4/VX32□4/VX33□4

Grommet: G

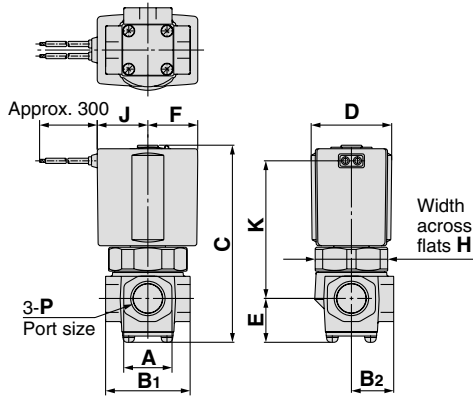

Conduit: C

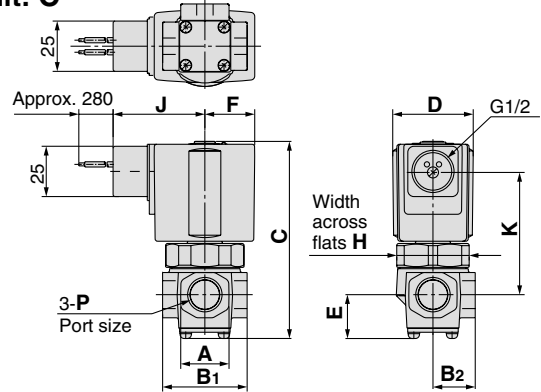

DIN terminal: D

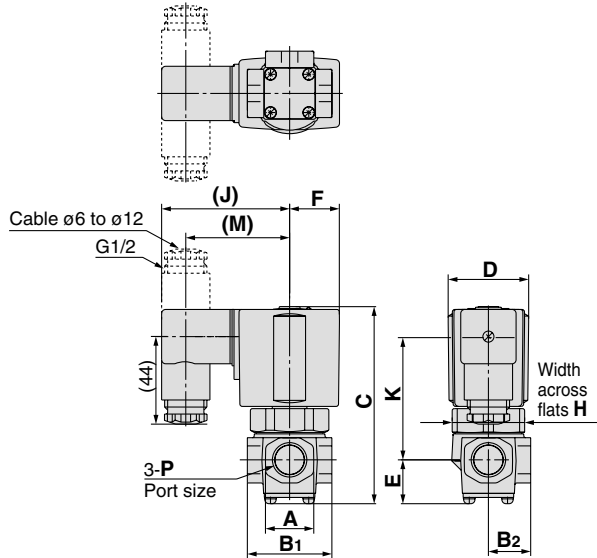

Conduit terminal: T

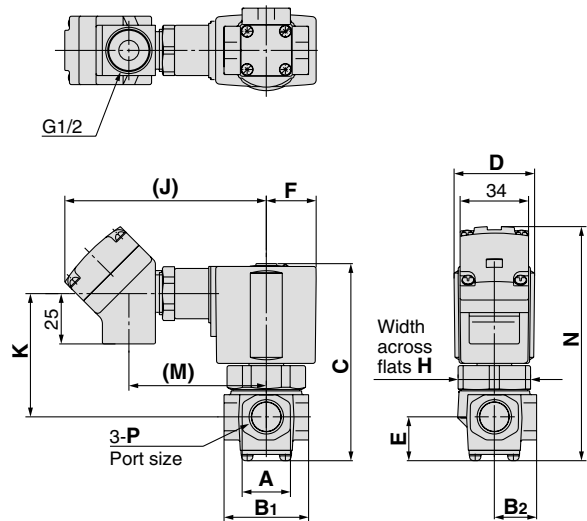

**Specifications with bracket**

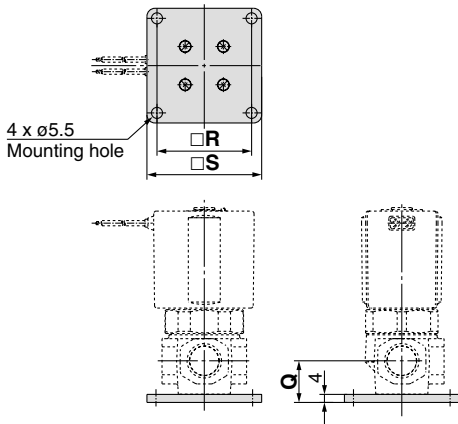

(mm)

Model	Orifice size	Port size P	Electrical entry (AC/Class B)										
			Grommet		Conduit		DIN terminal		Conduit terminal				
N.C., N.O., COM.			J	K	J	K	J	K	M	J	K	M	N
VX31□□	ø1.5,ø2.2,ø3	1/8	30	46	48.5	41	65.5	42	53.5	100.5	41	69.5	91.5
VX31□□	ø1.5,ø2.2,ø3	1/4											
VX32□□	ø2.2,ø3,ø4	1/4,3/8	33	56	51.5	51	68.5	52	56.5	103.5	51	72.5	105
VX33□□	ø2.2,ø3,ø4	1/4,3/8	36	64.5	54	59.5	71	60.5	59	106	59.5	75	113

(mm)

Model	Orifice size	Port size P	A	B		C	D	E	F	H	Electrical entry (DC, AC/Class H)								Bracket mounting					
				B <sub>1</sub>	B <sub>2</sub>						Grommet		Conduit		DIN terminal		Conduit terminal		Q	R	S			
											J	K	J	K	J	K	M	J				K	M	N
N.C., N.O., COM.																								
VX31□□	ø1.5,ø2.2,ø3	1/8	22	36	18	76.5	30	19	19.5	27	19.5	50	40	42.5	58.5	42	46.5	92	42.5	61	93	17.5	40	50
VX31□□	ø1.5,ø2.2,ø3	1/4		41	20.5																			
VX32□□	ø2.2,ø3,ø4	1/4,3/8	24	42	21	90	35	22	22.5	32	22.5	60	43	52.5	61.5	52	49.5	95	52.5	64	106.5	21	47	57
VX33□□	ø2.2,ø3,ø4	1/4,3/8	24	42	21	98	40	22	25	36	25.5	68.5	46	61	64	60.5	52	98	61	66.5	114.5	21	47	57

# Series VVX31/32/33

For Oil, Air/Manifold

## Dimensions: Manifold/Base Material: Aluminum

Normally closed (N.C.):

Normally open (N.O.): VVX31/VVX32/VVX33

Common (COM.):

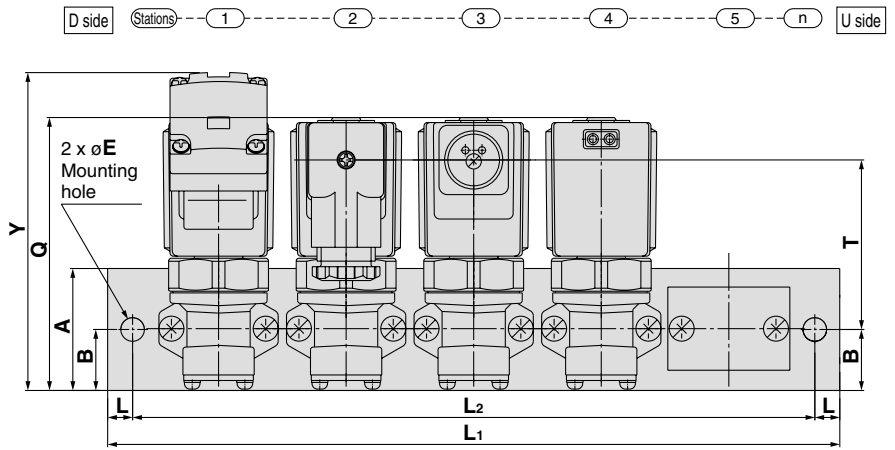
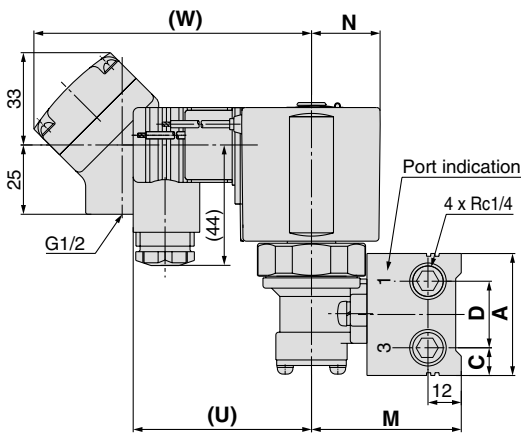
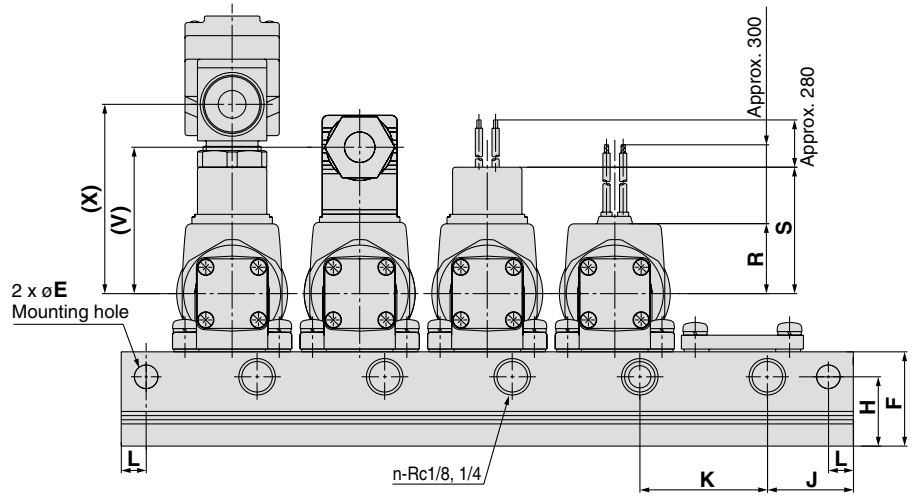

(mm)

Model	Dimension	n (stations)								
		2	3	4	5	6	7	8	9	10
VVX31	L1	96	132	168	204	240	276	312	348	384
	L2	84	120	156	192	228	264	300	336	372
VVX32	L1	126	172	218	264	310	356	402	448	494
VVX33	L2	108	154	200	246	292	338	384	430	476

(mm)

Model	A	B	C	D	E	F	H	J	K	L	M	N	Q	Electrical entry (DC, AC/Class H)								
														Grommet		Conduit		DIN terminal			Conduit terminal	
														R	S	T	T	U	V	W	X	Y
VVX31	40	20	9	22	6.5	33	24	26	36	6	49	19.5	80.5	19.5	40	45.5	45	58.5	46.5	92	61	97
VVX32	44	22	10	24	8.5	34	25	31	46	9	55	22.5	91	22.5	43	54	53.5	61.5	49.5	95	64	107.5
VVX33	44	22	10	24	8.5	34	25	31	46	9	55	25	99.5	25.5	46	62	61.5	64	52	98	66.5	116

(mm)

Model	Electrical entry (AC/Class B)								
	Grommet		Conduit		DIN terminal			Conduit terminal	
	R	S	T	T	U	V	W	X	Y
VVX31	30	48.5	44	45	65.5	53.5	100.5	69.5	95.5
VVX32	33	51.5	52.5	53.5	68.5	56.5	103.5	72.5	106
VVX33	36	54	60.5	61.5	71	59	106	75	114.5

# For Vacuum Pad Series VXV31/32/33

- Vacuum circuit side is suited for a large orifice. Supply pressure side is suited for high pressure and a vacuum pad.
- Construction and dimensions are the same as the VX3 series.

## Model/Valve Specifications

N.C.

N.O.

Passage symbol (example)

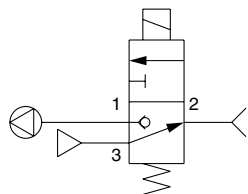

Passage symbol (example)

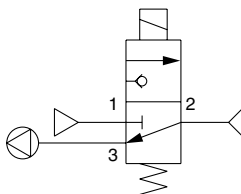

Port size	Orifice size (mmø)		Model	Operating pressure (MPa)		Flow characteristics						Max. system pressure (MPa)	Note) Weight (g)															
	Port 1 side	Port 3 side		Port 1 side	Port 3 side	Passage: 1↔2			Passage: 2↔3																			
						C[dm <sup>3</sup> /(s·bar)]	b	Cv	C[dm <sup>3</sup> /(s·bar)]	b	Cv																	
1/8 (6A)	3	1.5	VXV3130-01	Medium vacuum	0 to 0.5	0.82	0.20	0.20	0.29	0.32	0.08	2.0	380															
	1.5	3	VXV3132-01	0 to 0.5	Medium vacuum	0.29	0.32	0.08	0.82	0.20	0.20																	
1/4 (8A)	3	1.5	VXV3130-02	Medium vacuum	0 to 0.5	0.82	0.20	0.20	0.29	0.32	0.08			530														
	1.5	3	VXV3132-02	0 to 0.5	Medium vacuum	0.29	0.32	0.08	0.82	0.20	0.20				730													
	4	2.2	VXV3240-02	Medium vacuum	0 to 0.5	1.6	0.20	0.38	0.64	0.40	0.17					530												
			VXV3340-02	Medium vacuum	0 to 0.9												0.64	0.40	0.17	1.6	0.20	0.38						
	2.2	4	VXV3242-02	0 to 0.5	Medium vacuum	0.64	0.40	0.17	1.6	0.20	0.38												730					
			VXV3342-02	0 to 0.9	Medium vacuum																			0.64	0.40	0.17	1.6	0.20
3/8 (10A)	4	2.2	VXV3240-03	Medium vacuum	0 to 0.5	1.6	0.20	0.38	0.64	0.40	0.17			530														
			VXV3340-03	Medium vacuum	0 to 0.9										0.64													
	2.2	4	VXV3242-03	0 to 0.5	Medium vacuum	0.64	0.40	0.17	1.6	0.20	0.38					730												
			VXV3342-03	0 to 0.9	Medium vacuum												0.64	0.40	0.17	1.6	0.20	0.38						



Note) Weight of grommet type. Add 10 g for conduit, 30 g for DIN terminal, and 60 g for terminal type respectively.

Also, add 60 g for VX31□□, 80 g for VX32□□ and VX33□□ respectively for bracket option.

• Refer to "Glossary of Terms" on front matter 9, for details on the max. operating pressure differential and the max. system pressure.

## Operating Fluid and Ambient Temperature

Power source	Operating fluid temperature (°C)	Ambient temperature (°C)
AC (Class B), DC	-10 <sup>Note 1)</sup> to 60	-20 to 60



Note 1) Dew point temperature: -10°C or less

## Tightness of Valve (Leakage Rate)

Seal material	Leakage rate <sup>Note)</sup>
	NBR, FKM



Note) Value when air pressure is applied.

# Series VXV31/32/33

For Vacuum Pad/Single Unit

## How to Order (Single Unit)

**DC**  
**AC/Class B coil (with full-wave rectifier)**

**Model** • Refer to Table (1) shown below for availability.

**Orifice size** • Refer to Table (1) shown below for availability.

**Valve/Body configuration** •

0	N.C. / Single unit
2	N.O. / Single unit

**Solenoid valve option** • Refer to Table (2) shown below for availability.

**Port size** • Refer to Table (1) shown below for availability.

**Thread type** •

-	Rc
T	NPTF
F	G
N	NPT

**Suffix** •

-	—
Z	Oil free

**Rated voltage** •

1	100 VAC 50/60 Hz	6	12 VDC
2	200 VAC 50/60 Hz	7	240 VAC 50/60 Hz
3	110 VAC 50/60 Hz	8	48 VAC 50/60 Hz
4	220 VAC 50/60 Hz	J	230 VAC 50/60 Hz
5	24 VDC		

\* Refer to Table (3) shown below for availability.

Refer to page 3 for ordering coil only.

**Bracket** •

-	None
B	With bracket

\* Bracket is not removable.

**With full-wave rectifier, surge voltage suppressor**

**Electrical entry (AC/DC)**

<b>G</b> - Grommet <b>GS</b> - With grommet surge voltage suppressor		<b>C</b> - Conduit	
<b>T</b> - With conduit terminal <b>TS</b> - With conduit terminal and surge voltage suppressor <b>TL</b> - With conduit terminal and light <b>TZ</b> - With conduit terminal, surge voltage suppressor and light		<b>D</b> - DIN <b>DS</b> - DIN with surge voltage suppressor <b>DL</b> - DIN with light <b>DZ</b> - DIN with surge voltage suppressor and light <b>DO</b> - For DIN (without connector)	<b>Connector</b> 

\* Refer to Table (3) for the available combinations between each electrical option (S, L, Z) and rated voltage.  
 \* Surge voltage suppressor is integrated into the AC/Class B coil as standard.

**Table (1) Port/Orifice Size**

Model	Solenoid valve			Orifice symbol (diameter) <sup>Note)</sup>	
	VXV31	VXV32	VXV33	3 (1.5/3 mmø)	4 (2.2/4 mmø)
Port no. (Port size)	01 (1/8)	—	—	●	—
	02 (1/4)	—	—	●	—
	—	02 (1/4)	02 (1/4)	—	●
	—	03 (3/8)	03 (3/8)	—	●

Note) The orifice diameter shown above are for the supply pressure side/ vacuum side port.

**Table (2) Solenoid Valve Option**

Option symbol	Seal material		Body material	Guide pin material	Coil insulation type
	Main valve poppet	Fixed seals			
-	NBR	NBR	Brass (C37)	PPS	B
A	FKM	FKM			
G	NBR	NBR	Stainless steel		
H	FKM	FKM			

**Table (3) Rated Voltage – Electrical Option**

AC/DC	Rated voltage		Class B		
	Voltage symbol	Voltage	S With surge voltage suppressor	L With light	Z With light and surge voltage suppressor
AC	1	100 V	Note 1)	●	Note 1)
	2	200 V		●	
	3	110 V		●	
	4	220 V		—	
	7	240 V		—	
	8	48 V		—	
DC	J	230 V	—	—	—
	5	24 V	●	●	●
	6	12 V	●	—	—

Note 1) Option S, Z are not available as a surge voltage suppressor is integrated into the AC/Class B coil as standard.

\* Class H coil is not available.



# For Vacuum Pad/Manifold Series **VVXV31/32/33**

- Construction and dimensions are the same as those of the VVX3 series.

## Model/Valve Specifications

**N.C.**

**N.O.**

Passage symbol (example)

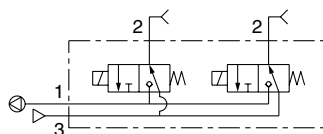

Passage symbol (example)

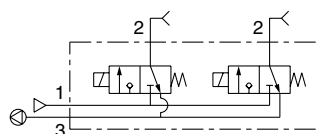

Orifice size (mmø)		Model	Operating pressure (MPa)		Flow characteristics						Max. system pressure (MPa)
Port 1 side	Port 3 side		Port 1 side	Port 3 side	Passage: 1↔2			Passage: 2↔3			
					C[dm <sup>3</sup> /(s·bar)]	b	Cv	C[dm <sup>3</sup> /(s·bar)]	b	Cv	
3	1.5	<b>VXV3131-00</b>	Medium vacuum	0 to 0.5	0.82	0.20	0.20	0.29	0.32	0.08	2.0
1.5	3	<b>VXV3133-00</b>	0 to 0.5	Medium vacuum	0.29	0.32	0.08	0.82	0.20	0.20	
4	2.2	<b>VXV3241-00</b>	Medium vacuum	0 to 0.5	1.6	0.20	0.38	0.64	0.40	0.17	
		<b>VXV3341-00</b>		0 to 0.9							
2.2	4	<b>VXV3243-00</b>	0 to 0.5	Medium vacuum	0.64	0.40	0.17	1.6	0.20	0.38	
		<b>VXV3343-00</b>	0 to 0.9								



• Refer to "Glossary of Terms" on front matter 9 for details on the max. operating pressure differential and the max. system pressure.

## Operating Fluid and Ambient Temperature

Power source	Operating fluid temperature (°C)	Ambient temperature (°C)
AC (Class B), DC	-10 <sup>Note 1)</sup> to 60	-20 to 60



Note 1) Dew point temperature: -10°C or less

## Tightness of Valve (Leakage Rate)

Seal material	Leakage rate <sup>Note)</sup>
	Air
NBR, FKM	1 cm <sup>3</sup> /min or less



Note) Value when air pressure is applied.

# Series VVXV31/32/33

For Vacuum Pad/Manifold

## How to Order (Solenoid Valve for Manifold)

**DC**  
**AC/Class B coil (with full-wave rectifier)**

VXV 31 3 1 [ ] [ ] - 00 - 5 G 1  
 VXV 31 3 1 [ ] [ ] - 00 - 1 G R1

**Model**  
 Refer to Table (1) shown below for availability.

**Valve/Body configuration**

1	N.C. / Manifold
3	N.O. / Manifold

**Orifice size**  
 Refer to Table (1) shown below for availability.

**Solenoid valve option**  
 Refer to Table (2) shown below for availability.

**Suffix**

-	—
Z	Oil free

**With full-wave rectifier, surge voltage suppressor**

**Rated voltage**

1	100 VAC 50/60 Hz	6	12 VDC
2	200 VAC 50/60 Hz	7	240 VAC 50/60 Hz
3	110 VAC 50/60 Hz	8	48 VAC 50/60 Hz
4	220 VAC 50/60 Hz	J	230 VAC 50/60 Hz
5	24 VDC		

\* Refer to Table (3) shown below for availability.

Refer to page 3 for ordering coil only.

**Electrical entry (AC/DC)**

**G** - Grommet  
**GS** - With grommet surge voltage suppressor

**C** - Conduit

**T** - With conduit terminal  
**TS** - With conduit terminal and surge voltage suppressor  
**TL** - With conduit terminal and light  
**TZ** - With conduit terminal, surge voltage suppressor and light

**D** - DIN  
**DS** - DIN with surge voltage suppressor  
**DL** - DIN with light  
**DZ** - DIN with surge voltage suppressor and light  
**DO** - For DIN (without connector)

\* DIN type is available with class B insulation only.

\* Refer to Table (3) for the available combinations between each electrical option (S, L, Z) and rated voltage.  
 \* Surge voltage suppressor is integrated into the AC/Class B coil as standard.

## How to Order Manifold Bases

VVX31  
 VVX32 1 - 07 - 1  
 VVX33

**Number of manifolds**

02	2 stations
.	.
.	.
10	10 stations

**Port size (Individual port)**

1	Rc1/8
2	Rc1/4

\* Common port sizes are all Rc1/4.  
 \* Indicating numbers shown below are for common ports.

Type	Vacuum side port	SUP side port
N.C.	1	3
N.O.	3	1

**Manifold base**

## Blanking plate part no.

For VXV31: VVX31-4A-[ ]  
 For VXV32/33: VVX32-4A-[ ]

**Seal material**

-	NBR
F	FKM

**Table (1) Port/Orifice Size**

Solenoid valve	Orifice symbol (diameter) <sup>Note)</sup>	
	3 (1.5/3 mmø)	4 (2.2/4 mmø)
VXV31	●	—
VXV32	—	●
VXV33	—	●

Note) The orifice diameter shows the supply pressure side/vacuum side.

**Table (2) Solenoid Valve Option**

Option symbol	Seal material		Body material	Guide pin material	Coil insulation type
	Main valve poppet	Fixed sealant			
-	NBR	NBR	Brass (C37)	PPS	B
A	FKM	FKM			

\* Aluminum is the only available material for the manifold base.

## How to Order Manifold Assemblies (Example)

Enter the valve and blanking plate to be mounted under the manifold base part number.

Example  
 VVX311-05-1 ..... 1 set    "\*" is the symbol for mounting.  
 \* VVX3131-00-1GR1... 4 sets    Add an "\*" in front of the part numbers  
 \* VVX31-4A ..... 1 set        for solenoid valves, etc. to be mounted.

Enter the product's part number in order, counting from the 1st station on the left in the manifold arrangement, when viewed with the individual ports in front. The common ports on the right side are plugged.

**Table (3) Rated Voltage – Electrical Option**

Rated voltage	AC/DC	Voltage symbol	Voltage	Class B		
				S	L	Z
AC	1	100 V	●	●	Note 1)	
	2	200 V	●	●		
	3	110 V	●	●		
	4	220 V	●	●		
	7	240 V	—	—		
	8	48 V	—	—		
DC	J	230 V	—	—		
	5	24 V	●	●	●	
	6	12 V	●	—	—	

\* Class H coil is not available.

Note 1) Option S, Z are not available as a surge voltage suppressor is integrated into the AC/Class B coil as standard.



# Series VX Safety Instructions

These safety instructions are intended to prevent a hazardous situation and/or equipment damage. These instructions indicate the level of potential hazard by labels of "Caution", "Warning" or "Danger". To ensure safety, be sure to observe ISO 4414 <sup>Note 1)</sup>, JIS B 8370 <sup>Note 2)</sup> and other safety practices.

**⚠ Caution :** Operator error could result in injury or equipment damage.

**⚠ Warning :** Operator error could result in serious injury or loss of life.

**⚠ Danger :** In extreme conditions, there is a possible result of serious injury or loss of life.

Note 1) ISO 4414: Pneumatic fluid power--General rules relating to systems.

Note 2) JIS B 8370: General Rules for Pneumatic Equipment

## ⚠ Warning

### **1. The compatibility of the pneumatic equipment is the responsibility of the person who designs the pneumatic system or decides its specifications.**

Since the products specified here are used in various operating conditions, their compatibility for the specific pneumatic system must be based on specifications or post analysis and/or tests to meet your specific requirements. The expected performance and safety assurance are the responsibility of the person who has determined the compatibility of the system. This person should continuously review the suitability of all items specified, referring to the latest catalogue information with a view to giving due consideration to any possibility of equipment failure when configuring a system.

### **2. Only trained personnel should operate pneumatically operated machinery and equipment.**

Compressed air can be dangerous if handled incorrectly. Assembly, handling or repair of pneumatic systems should be performed by trained and experienced operators.

### **3. Do not service machinery/equipment or attempt to remove components until safety is confirmed.**

1. Inspection and maintenance of machinery/equipment should only be performed once measures to prevent falling or runaway of the driven objects have been confirmed.
2. When equipment is removed, confirm that safety process as mentioned above. Turn off the supply pressure for this equipment and exhaust all residual compressed air in the system.
3. Before machinery/equipment is restarted, take measures to prevent quick extension of a cylinder piston rod, etc.

### **4. Contact SMC if the product will be used in any of the following conditions:**

1. Conditions and environments beyond the given specifications, or if product is used outdoors.
2. Installation on equipment in conjunction with atomic energy, railway, air navigation, vehicles, medical equipment, food and beverages, recreation equipment, emergency stop circuits, clutch and brake circuits in press applications, or safety equipment.
3. An application which has the possibility of having negative effects on people, property, or animals, requiring special safety analysis.



# 3 Port Solenoid Valve for Fluid Control/Precautions 1

Be sure to read this before handling.

For detailed precautions on each series, refer to the main text.

## Design

### Warning

#### 1. Cannot be used as an emergency shutoff valve, etc.

The valves presented in this catalogue are not designed for safety applications such as an emergency shutoff valve. If the valves are used in this type of system, other reliable safety assurance measures should also be adopted.

#### 2. Extended periods of continuous energisation

The solenoid coil will generate heat when continuously energised. Avoid using in a tightly shut container. Install it in a well-ventilated area. Furthermore, do not touch it while it is being energised or right after it is energised.

#### 3. This solenoid valve cannot be used for explosion proof applications.

#### 4. Maintenance space

The installation should allow sufficient space for maintenance activities (removal of valve, etc.).

#### 5. Liquid rings

In cases with a flowing liquid, provide a bypass valve in the system to prevent the liquid from entering the liquid seal circuit.

#### 6. Actuator drive

When an actuator, such as a cylinder, is to be driven using a valve, take appropriate measures to prevent potential danger caused by actuator operation.

#### 7. Pressure (including vacuum) holding

It is not usable for an application such as holding the pressure (including vacuum) inside of a pressure vessel because air leakage is entailed in a valve.

#### 8. When the conduit type is used as equivalent to an IP65 enclosure, install a wiring conduit, etc.

#### 9. When an impact, such as water hammer, etc., caused by the rapid pressure fluctuation is applied, the solenoid valve may be damaged. Please pay attention to this.

## Selection

### Warning

#### 1. Confirm the specifications.

Give careful consideration to the operating conditions such as the application, fluid and environment, and use within the operating ranges specified in this catalogue.

#### 2. Fluid

##### 1) Type of fluid

Before using a fluid, confirm whether it is compatible with the materials from each model by referring to the fluids listed in this catalogue. Use a fluid with a kinematic viscosity of 50 mm<sup>2</sup>/s or less. If there is something you do not know, please contact SMC.

##### 2) Inflammable oil, Gas,

Confirm the specification for leakage in the interior and/or exterior area.

## Selection

### Warning

#### 3) Corrosive gas

Cannot be used since it will lead to cracks by stress corrosion or result in other incidents.

#### 4) Use an oil-free specification when oil particles must not enter the fluid passage.

#### 5) Applicable fluid on the list may not be used depending on the operating condition. Just because the compatibility list shows the general case, still give adequate confirmation when selecting a model.

#### 3. Fluid quality

The use of a fluid which contains foreign matter can cause problems such as malfunction and seal failure by promoting wear of the valve seat and armature, and by sticking to the sliding parts of the armature, etc. Install a suitable filter (strainer) immediately upstream from the valve. As a general rule, use 80 to 100 mesh. When used to supply water to boilers, substances such as calcium and magnesium which generate hard scale and sludge are included. Since this scale and sludge can cause the valve to malfunction, install water softening equipment, and a filter (strainer) directly upstream from the valve to remove these substances.

#### 4. Air quality

##### 1) Use clean air.

Do not use compressed air which includes chemicals, synthetic oils containing organic solvents, salt or corrosive gases, etc., as it can cause damage or malfunction.

##### 2) Install air filters.

Install air filters close to the valves on their upstream side. A filtration degree of 5µm or less should be selected.

##### 3) Install an air dryer or after cooler, etc.

Compressed air that includes excessive drainage may cause malfunction of valves and other pneumatic equipment. To prevent this, install an air dryer or after cooler, etc.

##### 4) If excessive carbon powder is generated, eliminate it by installing mist separators on the upstream side of the valves.

If excessive carbon powder is generated by the compressor, it may adhere to the inside of the valves and cause a malfunction.

Refer to SMC's Best Pneumatics catalogue for further details on compressed air quality.

#### 5. Ambient environment

Use within the operable ambient temperature range. Confirm the compatibility between the product's composition materials and the ambient atmosphere. Be sure that the fluid used does not touch the external surface of the product.

#### 6. Countermeasures against static electricity

Take measures to prevent static electricity since some fluids can cause static electricity.

#### 7. For the low particle generation specification, please contact SMC.



# 3 Port Solenoid Valve for Fluid Control/Precautions 2

Be sure to read this before handling.

For detailed precautions on each series, refer to the main text.

## Selection

### ⚠ Caution

#### 1. Leakage voltage

Particularly when using a resistor in parallel with a switching element and using a C-R element (surge voltage suppressor) to protect the switching element, take note that leakage current will flow through the resistor, C-R element, etc., creating a possible danger that the valve may not turn off.

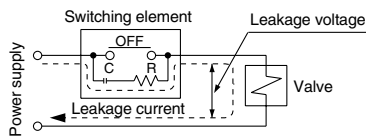

- AC/Class B coil: 5% or less of rated voltage
- AC/Class H coil: 20% or less of rated voltage
- DC coil: 2% or less of rated voltage

#### 2. Low temperature operation

1. The valve can be used in an ambient temperature of between  $-10$  to  $-20^{\circ}\text{C}$ , however take measures to prevent freezing or solidification of impurities, etc.
2. When using valves for water application in cold climates, take appropriate countermeasures to prevent the water from freezing in tubing after cutting the water supply from the pump, by draining the water, etc. When heating by steam, be careful not to expose the coil portion to steam. Installation of a dryer or heat retaining of the body is recommended to prevent a freezing condition in which the dew point temperature is high and the ambient temperature is low, and the high flow runs.

## Mounting

### ⚠ Warning

#### 1. If air leakage increases or equipment does not operate properly, stop operation.

After mounting is completed, confirm that it has been done correctly by performing a suitable function test.

#### 2. Do not apply external force to the coil section.

When tightening is performed, apply a wrench or other tool to the outside of the piping connection parts.

#### 3. Be sure not to position the coil downwards.

When mounting a valve with its coil positioned downwards, foreign objects in the fluid will adhere to the iron core leading to a malfunction.

#### 4. Do not warm the coil assembly with a heat insulator, etc.

Use tape, heaters, etc., for freeze prevention on the piping and body only. They can cause the coil to burn out.

#### 5. Secure with brackets, except in the case of steel piping and copper fittings.

#### 6. Avoid sources of vibration, or adjust the arm from the body to the minimum length so that resonance will not occur.

#### 7. Painting and coating

Warnings or specifications printed or labelled on the product should not be erased, removed or covered up.

## Piping

### ⚠ Caution

#### 1. Preparation before piping

Before piping is connected, it should be thoroughly blown out with air (flushing) or washed to remove chips, cutting oil and other debris from inside the pipe.

#### 2. Wrapping of pipe tape

When connecting pipes, fittings, etc., be sure that chips from the pipe threads and sealing material do not enter the valve.

Furthermore, when pipe tape is used, leave 1.5 to 2 thread ridges exposed at the end of the threads.

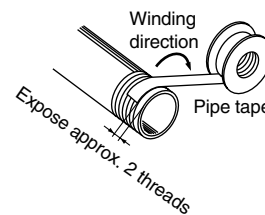

#### 3. Avoid connecting ground lines to piping, as this may cause electric corrosion of the system.

#### 4. Always tighten threads with the proper tightening torque.

When attaching fittings to valves, tighten with the proper tightening torque shown below.

#### Tightening Torque for Piping

Connection threads	Proper tightening torque N·m
Rc 1/8	7 to 9
Rc 1/4	12 to 14
Rc 3/8	22 to 24
Rc 1/2	28 to 30

#### 5. Connection of piping to products

When connecting piping to a product, refer to its instruction manual to avoid mistakes regarding the supply port, etc.

#### 6. Steam generated in a boiler contains a large amount of drainage.

Be sure to operate it with a drain trap installed.

#### 7. In applications such as vacuum and non-leak specifications, use caution specifically against the contamination of foreign matters or airtightness of the fittings.



# 3 Port Solenoid Valve for Fluid Control/Precautions 3

Be sure to read this before handling.

For detailed precautions on each series, refer to the main text.

## Wiring

### ⚠ Caution

- As a rule, use electrical wire with a cross sectional area of 0.5 to 1.25mm<sup>2</sup> for wiring. Furthermore, do not allow excessive force to be applied to the lines.
- Use electrical circuits which do not generate chattering in their contacts.
- Use voltage which is within  $\pm 10\%$  of the rated voltage. In cases with a DC power supply where importance is placed on responsiveness, stay within  $\pm 5\%$  of the rated value. The voltage drop is the value in the lead wire section connecting the coil.
- When a surge from the solenoid affects the electrical circuitry, install a surge absorber, etc., in parallel with the solenoid. Or, adopt the option that comes with the surge voltage protection circuit. (However, a surge voltage occurs even if the surge voltage protection circuit is used. For details, please contact SMC.)

## Electrical Connections

### ⚠ Caution

#### Grommet

Class H coil: AWG18 Insulator O.D. 2.2 mm

Class B coil: AWG20 Insulator O.D. 2.4 mm

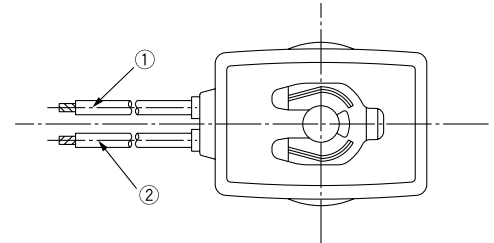

Rated voltage	Lead wire colour	
	①	②
DC (Class B only)	Black	Red
100 VAC	Blue	Blue
200 VAC	Red	Red
Other AC	Gray	Gray

\* There is no polarity.

#### DIN connector (Class B only)

Since internal connections are as shown below for the DIN connector, make connections to the power supply accordingly.

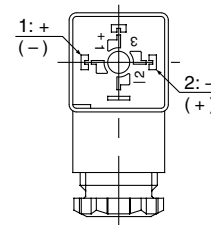

Terminal no.	1	2
DIN terminal	+ (-)	- (+)

\* There is no polarity.

- Use compatible heavy duty cords with cable O.D. of  $\phi 6$  to 12.
- Use the tightening torques below for each section.

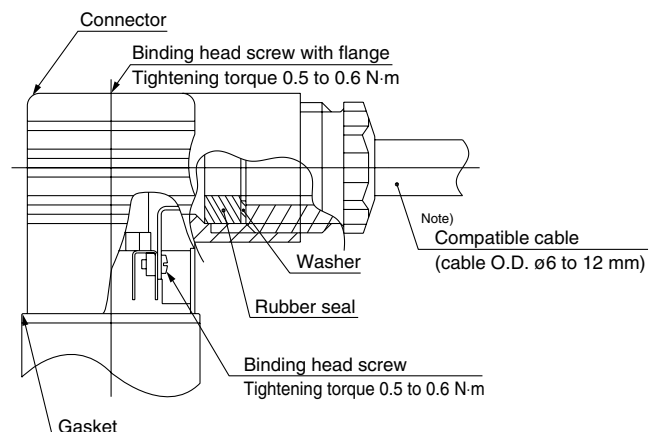

Note) For an outside cable diameter of  $\phi 9$  to 12 mm, remove the internal parts of the rubber seal before using.



# 3 Port Solenoid Valve for Fluid Control/Precautions 4

Be sure to read this before handling.

For detailed precautions on each series, refer to the main text.

## Electrical Connections

### Caution

#### Conduit terminal

In the case of the conduit terminal, make connections according to the marks shown below.

- Use the tightening torques below for each section.
- Properly seal the terminal connection (G1/2) with the special wiring conduit, etc.

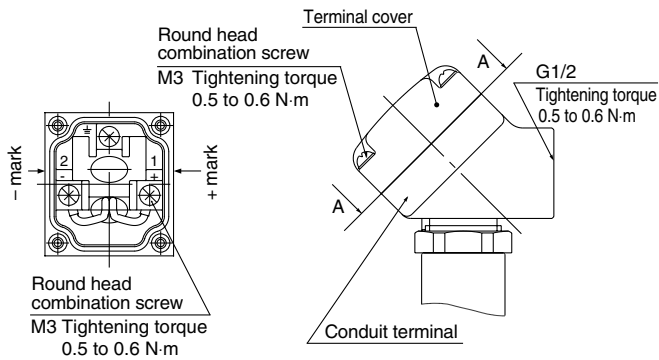

View A-A

(Internal connection diagram)

#### Conduit

When used as an IP65 equivalent, use seal (part no. VCW20-15-6) to install the wiring conduit. Also, use the tightening torque below for the conduit.

- Class H coil: AWG18 Insulator O.D. 2.2 mm
- Class B coil: AWG20 Insulator O.D. 2.4 mm

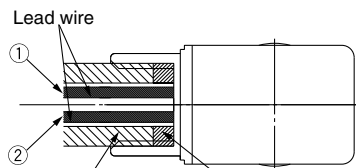

Wiring conduit Seal (VCW20-15-6)

Bore size G1/2 Tightening torque 0.5 to 0.6 N·m

Rated voltage	Lead wire colour	
	①	②
DC	Black	Red
100 VAC	Blue	Blue
200 VAC	Red	Red
Other AC	Gray	Gray

\* There is no polarity for DC.

Description	Part no.
Seal	VCW20-15-6

Note) Please order separately.

## Electrical Circuits

### Caution

#### DC circuit

##### Grommet, Conduit, Conduit terminal, DIN connector

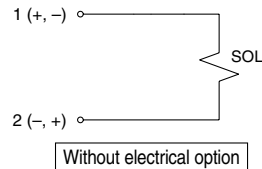

##### Grommet, Conduit terminal, DIN connector

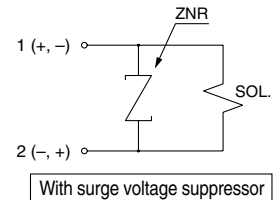

##### Conduit terminal, DIN connector

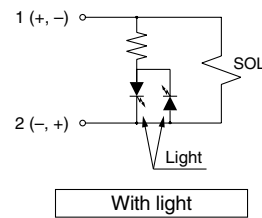

##### Conduit terminal, DIN connector

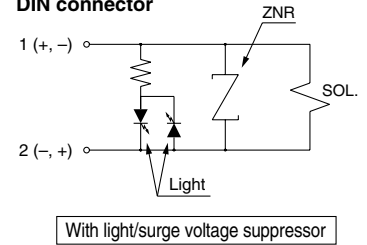

#### AC/Class B coil circuit

##### Grommet, Conduit, Conduit terminal, DIN connector

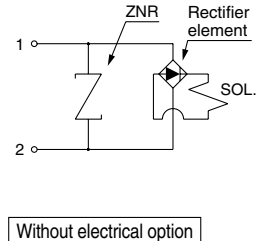

\* Surge voltage suppressor is attached to the AC/Class B coil as standard.

##### Conduit terminal, DIN connector

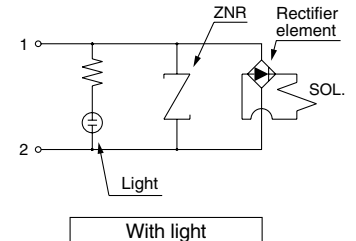

#### AC/Class H coil circuit

##### Grommet, Conduit, Conduit terminal

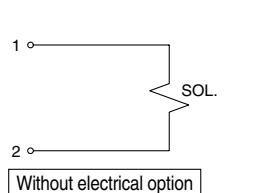

##### Grommet, Conduit terminal

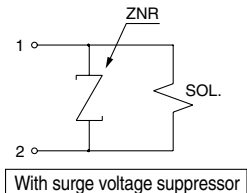

##### Conduit terminal

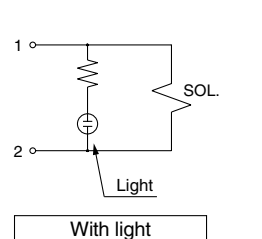

##### Conduit terminal

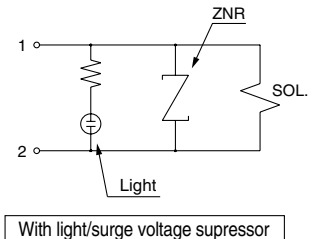



# 3 Port Solenoid Valve for Fluid Control/Precautions 5

Be sure to read this before handling.

For detailed precautions on each series, refer to the main text.

## Operating Environment

### Warning

1. Do not use the valves in an atmosphere having corrosive gases, chemicals, salt water, water, steam, or where there is direct contact with any of these.
2. Do not use in explosive atmospheres.
3. Do not use in locations subject to vibration or impact.
4. Do not use in locations where radiated heat will be received from nearby heat sources.
5. Employ suitable protective measures in locations where there is contact with water droplets, oil or welding spatter, etc.

## Lubrication

### Caution

1. This solenoid valve can be operated without lubrication.

If a lubricant is used in the system, use turbine oil Class 1, ISO VG32 (with no additive). But do not lubricate a valve with EPDM seal.

Refer to the table of brand name of lubricants compliant with Class 1 turbine oil (with no additive), ISO VG32.

#### Class 1 Turbine Oil (with no additive), ISO VG32

Classification of viscosity (cst) (40°C)	Viscosity according to ISO Grade	32
Idemitsu Kosan Co.,Ltd.		Turbine oil P-32
Nippon Oil Corp.		Turbine oil 32
Cosmo Oil Co.,Ltd.		Cosmo turbine 32
Japan Energy Corp.		Kyodo turbine 32
Kygnus Oil Co.		Turbine oil 32
Kyushu Oil Co.		Stork turbine 32
Nippon Oil Corp.		Mitsubishi turbine 32
Showa Shell Sekiyu K.K.		Turbine 32
Tonen General Sekiyu K.K.		General R turbine 32
Fuji Kosan Co.,Ltd.		Fucoal turbine 32

Please contact SMC regarding Class 2 turbine oil (with additives), ISO VG32.

## Maintenance

### Warning

#### 1 Removing the product

The valve will reach a high temperature when used with high temperature fluids. Confirm that the valve temperature has dropped sufficiently before performing work. If touched inadvertently, there is a danger of being burned.

1. Shut off the fluid supply and release the fluid pressure in the system.
2. Shut off the power supply.
3. Demount the product.

#### 2. Low frequency operation

Switch valves at least once every 30 days to prevent malfunction. Also, in order to use it under the optimum state, conduct a regular inspection once every six months.

## Maintenance

### Caution

#### 1. Filters and strainers

1. Be careful regarding clogging of filters and strainers.
2. Replace filter elements after one year of use, or earlier if the pressure drop reaches 0.1 MPa.
3. Clean strainers when the pressure drop reaches 0.1 MPa.

#### 2. Lubrication

When using with lubrication, never forget to lubricate continuously.

#### 3. Storage

In case of long term storage after use with heated water, thoroughly remove all moisture to prevent rust and deterioration of rubber materials, etc.

#### 4. Exhaust the drain from an air filter periodically.

## Operating Precautions

### Warning

1. Valves will reach high temperatures when used with high temperature fluids. Use caution, as there is a danger of being burned if the valve is directly touched.











## EUROPEAN SUBSIDIARIES:



### Austria

SMC Pneumatik GmbH (Austria).  
Girakstrasse 8, A-2100 Korneuburg  
Phone: +43 2262-62280, Fax: +43 2262-62285  
E-mail: office@smc.at  
http://www.smc.at



### France

SMC Pneumatique, S.A.  
1, Boulevard de Strasbourg, Parc Gustave Eiffel  
Bussy Saint Georges F-77607 Marne La Vallée Cedex 3  
Phone: +33 (0)1-6476 1000, Fax: +33 (0)1-6476 1010  
E-mail: contact@smc-france.fr  
http://www.smc-france.fr



### Netherlands

SMC Pneumatics BV  
De Ruyterkade 120, NL-1011 AB Amsterdam  
Phone: +31 (0)20-5318888, Fax: +31 (0)20-5318880  
E-mail: info@smcpneumatics.nl  
http://www.smcpneumatics.nl



### Spain

SMC España, S.A.  
Zuazobidea 14, 01015 Vitoria  
Phone: +34 945-184 100, Fax: +34 945-184 124  
E-mail: post@smc.smces.es  
http://www.smces.es



### Belgium

SMC Pneumatics N.V./S.A.  
Nijverheidsstraat 20, B-2160 Wommelgem  
Phone: +32 (0)3-355-1464, Fax: +32 (0)3-355-1466  
E-mail: post@smcpneumatics.be  
http://www.smcpneumatics.be



### Germany

SMC Pneumatik GmbH  
Boschring 13-15, D-63329 Egelsbach  
Phone: +49 (0)6103-4020, Fax: +49 (0)6103-402139  
E-mail: info@smc-pneumatik.de  
http://www.smc-pneumatik.de



### Norway

SMC Pneumatics Norway A/S  
Vollsveien 13 C, Granfos Næringspark N-1366 Lysaker  
Tel: +47 67 12 90 20, Fax: +47 67 12 90 21  
E-mail: post@smc-norge.no  
http://www.smc-norge.no



### Sweden

SMC Pneumatics Sweden AB  
Ekhagsvägen 29-31, S-141 71 Huddinge  
Phone: +46 (0)8-603 12 00, Fax: +46 (0)8-603 12 90  
E-mail: post@smcpneumatics.se  
http://www.smc.nu



### Bulgaria

SMC Industrial Automation Bulgaria EOOD  
16 klement Ohridski Blvd., fl.13 BG-1756 Sofia  
Phone: +359 2 9744492, Fax: +359 2 9744519  
E-mail: office@smc.bg  
http://www.smc.bg



### Greece

S. Parianosopoulos S.A.  
7, Konstantinoupoleos Street, GR-11855 Athens  
Phone: +30 (0)1-3426076, Fax: +30 (0)1-3455578  
E-mail: parianos@hol.gr  
http://www.smceu.com



### Poland

SMC Industrial Automation Polska Sp.z.o.o.  
ul. Konstruktorska 11A, PL-02-673 Warszawa,  
Phone: +48 22 548 5085, Fax: +48 22 548 5087  
E-mail: office@smc.pl  
http://www.smc.pl



### Switzerland

SMC Pneumatik AG  
Dorfstrasse 7, CH-8484 Weisslingen  
Phone: +41 (0)52-396-3131, Fax: +41 (0)52-396-3191  
E-mail: info@smc.ch  
http://www.smc.ch



### Croatia

SMC Industrijska automatika d.o.o.  
Crnomerec 12, 10000 ZAGREB  
Phone: +385 1 377 66 74, Fax: +385 1 377 66 74  
E-mail: office@smc.hr  
http://www.smceu.com



### Hungary

SMC Hungary Ipari Automatizálási Kft.  
Budafoki út 107-113, H-1117 Budapest  
Phone: +36 1 371 1343, Fax: +36 1 371 1344  
E-mail: office@smc-automation.hu  
http://www.smc-automation.hu



### Portugal

SMC Sucursal Portugal, S.A.  
Rua de Engº Ferreira Dias 452, 4100-246 Porto  
Phone: +351 22-610-89-22, Fax: +351 22-610-89-36  
E-mail: postpt@smc.smces.es  
http://www.smces.es



### Turkey

Entek Pnömatik San. ve Tic Ltd. Sti.  
Perpa Tic. Merkezi Kat: 11 No: 1625, TR-80270 Okmeydanı Istanbul  
Phone: +90 (0)212-221-1512, Fax: +90 (0)212-221-1519  
E-mail: smc-entek@entek.com.tr  
http://www.entek.com.tr



### Czech Republic

SMC Industrial Automation CZ s.r.o.  
Hudcova 78a, CZ-61200 Brno  
Phone: +420 5 414 24611, Fax: +420 5 412 18034  
E-mail: office@smc.cz  
http://www.smc.cz



### Ireland

SMC Pneumatics (Ireland) Ltd.  
2002 Citywest Business Campus, Naas Road, Saggart, Co. Dublin  
Phone: +353 (0)1-403 9000, Fax: +353 (0)1-464-0500  
E-mail: sales@smcpneumatics.ie  
http://www.smcpneumatics.ie



### Romania

SMC Romania srl  
Str Frunzei 29, Sector 2, Bucharest  
Phone: +40 213205111, Fax: +40 213261489  
E-mail: smcromania@smcromania.ro  
http://www.smcromania.ro



### UK

SMC Pneumatics (UK) Ltd  
Vincent Avenue, Crownhill, Milton Keynes, MK8 0AN  
Phone: +44 (0)800 1382930 Fax: +44 (0)1908-555064  
E-mail: sales@smcpneumatics.co.uk  
http://www.smcpneumatics.co.uk



### Denmark

SMC Pneumatik A/S  
Knudsminde 4B, DK-8300 Odder  
Phone: +45 70252900, Fax: +45 70252901  
E-mail: smc@smc-pneumatik.dk  
http://www.smcdk.com



### Italy

SMC Italia S.p.A  
Via Garibaldi 62, I-20061 Carugate, (Milano)  
Phone: +39 (0)2-927211, Fax: +39 (0)2-9271365  
E-mail: mailbox@smcitalia.it  
http://www.smcitalia.it



### Russia

SMC Pneumatik LLC.  
4B Sverdlovskaja nab, St. Petersburg 195009  
Phone: +812 718 5445, Fax: +812 718 5449  
E-mail: info@smc-pneumatik.ru  
http://www.smc-pneumatik.ru



### Estonia

SMC Pneumatics Estonia OÜ  
Laki 12-101, 106 21 Tallinn  
Phone: +372 (0)6 593540, Fax: +372 (0)6 593541  
E-mail: smc@smcpneumatics.ee  
http://www.smcpneumatics.ee



### Latvia

SMC Pneumatics Latvia SIA  
Smerla 1-705, Riga LV-1006, Latvia  
Phone: +371 781-77-00, Fax: +371 781-77-01  
E-mail: info@smclv.lv  
http://www.smclv.lv



### Slovakia

SMC Priemyselná Automatizácia, s.r.o.  
Námestie Martina Benku 10, SK-81107 Bratislava  
Phone: +421 2 444 56725, Fax: +421 2 444 56028  
E-mail: office@smc.sk  
http://www.smc.sk



### Finland

SMC Pneumatics Finland OY  
PL72, Tiistiniityntie 4, SF-02031 ESPOO  
Phone: +358 207 513513, Fax: +358 207 513595  
E-mail: smcfin@smc.fi  
http://www.smc.fi



### Lithuania

SMC Pneumatics Lietuva, UAB  
Savanoriu pr. 180, LT-01354 Vilnius, Lithuania  
Phone: +370 5 264 81 26, Fax: +370 5 264 81 26



### Slovenia

SMC industrijska Avtomatika d.o.o.  
Grajski trg 15, SLO-8360 Zuzemberk  
Phone: +386 738 85240 Fax: +386 738 85249  
E-mail: office@smc-ind-avtom.si  
http://www.smc-ind-avtom.si



## OTHER SUBSIDIARIES WORLDWIDE:

ARGENTINA, AUSTRALIA, BOLIVIA, BRASIL, CANADA, CHILE,  
CHINA, HONG KONG, INDIA, INDONESIA, MALAYSIA, MEXICO,  
NEW ZEALAND, PHILIPPINES, SINGAPORE, SOUTH KOREA,  
TAIWAN, THAILAND, USA, VENEZUELA

<http://www.smceu.com>  
<http://www.smcworld.com>