

# Venus638 Family GPS Module

## Data Sheet

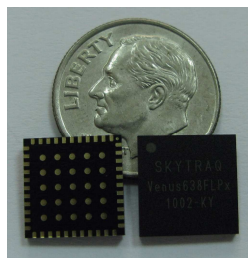

10mmx 10mm

Venus638LPx-L / Venus638LPx-D  
Venus638FLPx-L / Venus638FLPx-D

## FEATURES

- GPS receiver in 10mm x 10mm x 1.3mm size
- Tests 8 million time-frequency hypothesis per sec
- Open sky cold start 29 second
- Signal detection better than -161dBm
- Accuracy 2.5m CEP
- 10Hz maximum update rate
- Multipath detection and suppression
- Data logging with external SPI serial Flash
- Supports active or passive antenna
- Pb free RoHS compliant

The Venus638 is a module-in-a-chip design targeting mobile consumer and cellular handset applications. It offers very low current consumption, high sensitivity, and best in class signal acquisition and time-to-first-fix performance.

The Venus638 contains all the necessary components of a complete GPS receiver module, includes 1.2dB cascaded system NF RF front-end, GPS baseband signal processor, 0.5ppm TCXO, 32.768kHz RTC crystal, RTC LDO regulator, and passive components. It requires very low external component count and takes up only 100mm<sup>2</sup> PCB footprint.

Dedicated massive-correlator signal parameter search engine within the baseband enables rapid search of all the available satellites and acquisition of very weak signal. An advanced track engine allows weak signal tracking and positioning in harsh environments such as urban canyons and under deep foliage.

Product Series	Product Description
Venus638LPx-L	ROM version GPS receiver module (internal 1.2V LDO version) Suitable for Venus634LPx direct drop-in replacement
Venus638LPx-D	ROM version GPS receiver module (external 1.2V version) Suitable for lower power application with 1.2V supply
Venus638FLPx-L	Flash version GPS receiver module (internal 1.2V LDO version) Suitable for Venus634FLPx direct drop-in replacement
Venus638FLPx-D	Flash version GPS receiver module (external 1.2V version) Suitable for lower power application with 1.2V supply

# TECHNICAL SPECIFICATIONS

Receiver Type	L1 Frequency GPS C/A code SBAS Capable 51 Channel Acquisitions 14 Channel Tracking
Accuracy	Position 2.5m CEP Velocity 0.1m/sec Timing 300ns
Open Sky TTFF	Hot start 1 second Cold start 29 seconds average
Reacquisition	< 1s
Sensitivity	Tracking -161dBm
Update Rate	1Hz standard (up to 10Hz)
Dynamics	4G
Operational Limits	Altitude < 18,000m <sup>*1</sup> , Velocity < 515m/s <sup>*1</sup>
Datum	Default WGS-84
Interface	UART LVTTTL level
Baud Rate	4800 / 9600 / 38400 / 115200
Protocol	NMEA-0183 V3.01, GGA, GLL, GSA, GSV, RMC, VTG (default GGA, GSA, GSV, RMC, VTG) SkyTraQ Binary
Main Supply Voltage	2.8V ~ 3.6V (Venus638LPx-L, Venus638FLPx-L) 2.8V ~ 3.6V, 1.08V ~ 1.32V (Venus638LPx-D, Venus638FLPx-D)
Backup Voltage	1.5V ~ 6V
Current Consumption	

	Enhanced Acquisition	Low Power Acquisition	Tracking
Venus638LPx-L	65mA @ 3.3V	47mA @ 3.3V	26mA @ 3.3V
Venus638LPx-D	15mA @ 3.3V 50mA @ 1.2V	15mA @ 3.3V 32mA @ 1.2V	15mA @ 3.3V 11mA @ 1.2V
Venus638FLPx-L	68mA @ 3.3V	50mA @ 3.3V	29mA @ 3.3V
Venus638FLPx-D	18mA @ 3.3V 50mA @ 1.2V	18mA @ 3.3V 32mA @ 1.2V	18mA @ 3.3V 11mA @ 1.2V

Assuming 75% efficiency switch-mode 3.3V-to-1.2V regulator is used, then

	Enhanced Acquisition	Low Power Acquisition	Tracking
Venus638LPx-D	39mA @ 3.3V	30mA @ 3.3V	20mA @ 3.3V
Venus638FLPx-D	42mA @ 3.3V	33mA @ 3.3V	23mA @ 3.3V

Operating Temperature	-40 ~ +85 deg-C
Storage Temperature	-40 ~ +125 deg-C
Package	LGA69 10mm x 10mm x 1.3mm, 0.8mm pitch

\*1: COCOM limit, either may be exceeded but not both for Flash-type Venus638FLPx; both must not be exceeded for ROM-type Venus638LPx

# BLOCK DIAGRAM

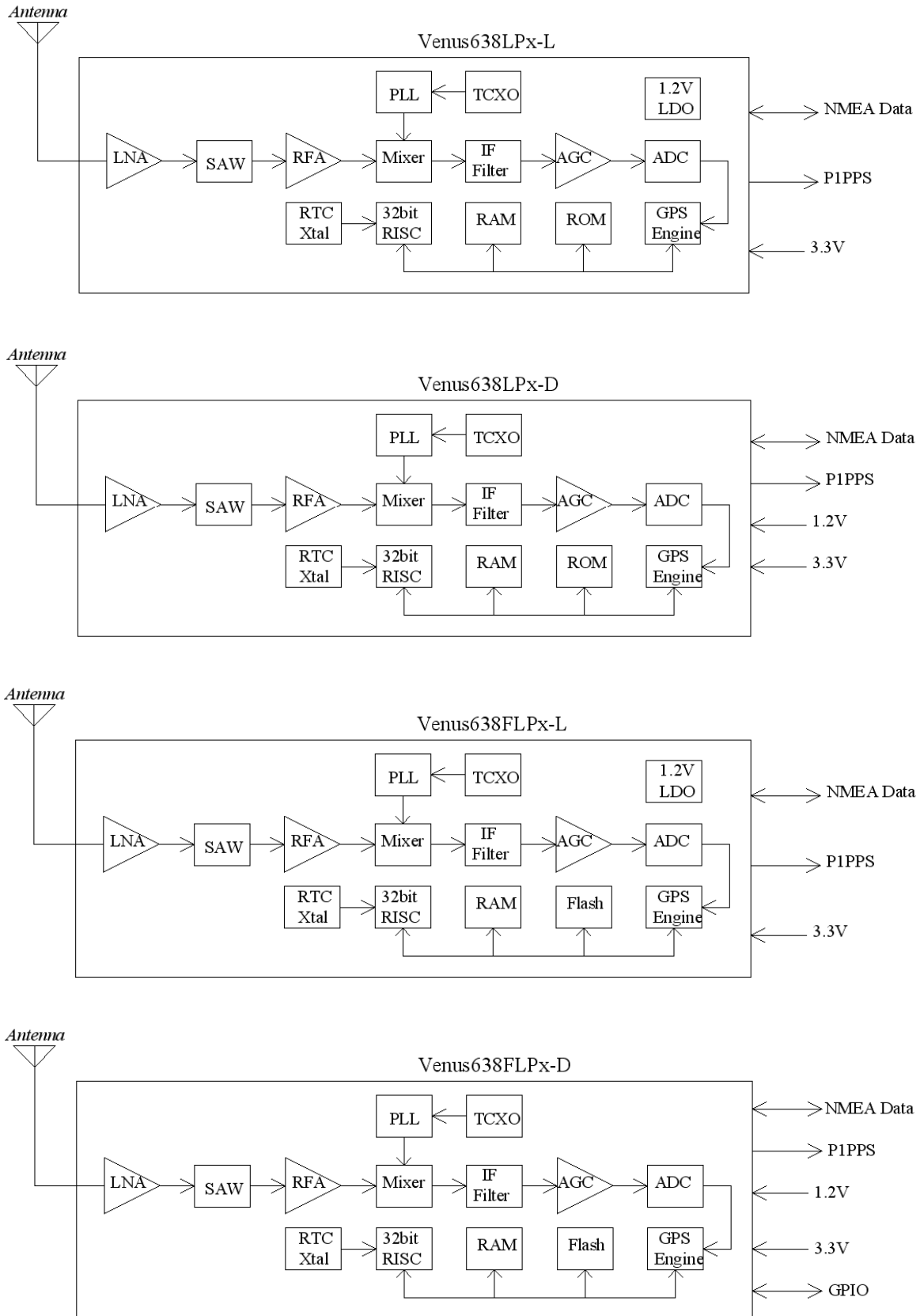

Figure-1 GPS Receiver based on Venus638

## Venus638LPx PIN-OUT DIAGRAM

### Venus638LPx-L / Venus638LPx-D Top View

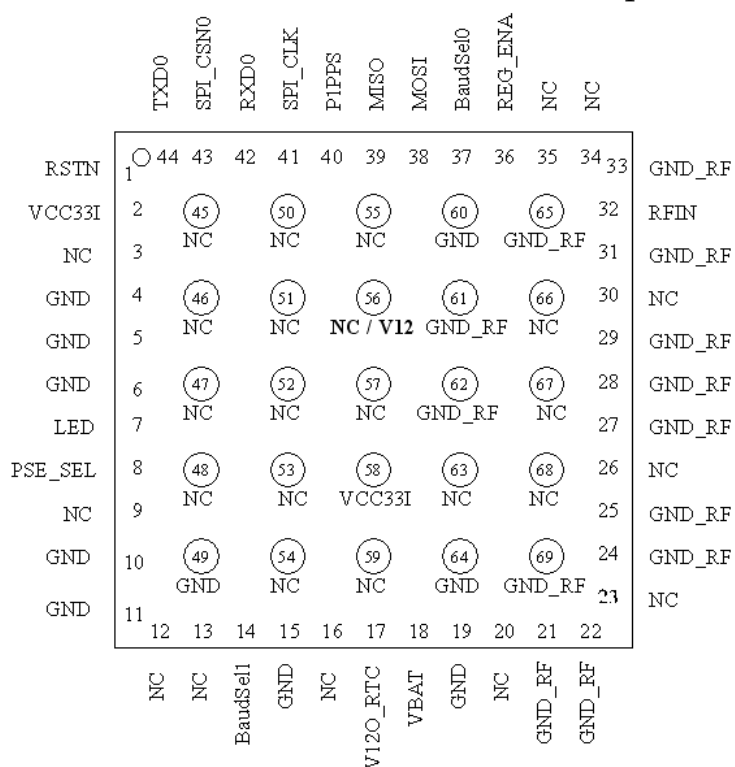

Figure-2a Venus638LPx Pin-Out Diagram

## VENUS638LPx PIN DEFINITION

Pin Number	Signal Name	Type	Description
1	RSTN	Input	Active LOW reset input. 3.3V LVTTTL
2	VCC33I	Power Input	Main voltage supply input, 2.8V ~ 3.6V
3	NC		Not connected, empty pin
4	GND	Power	System ground
5	GND	Power	System ground
6	GND	Power	System ground
7	LED	Output	Navigation status indicator.
8	PSE_SEL	Input	Search engine mode selection 1: low power mode 0: enhanced acquisition mode 3.3V LVTTTL
9	NC		Not connected, empty pin
10	GND	Power	System ground
11	GND	Power	System ground
12	NC		Not connected, empty pin
13	NC		Not connected, empty pin
14	BAUDSEL1	Input	Hardware baud rate selection, used with BaudSel0. BaudSel[1:0] = 00 for 9600 baud, 01 for 4800 baud, 10 for 38400 baud, 11 for 115200 baud 3.3V LVTTTL
15	GND	Power	System ground
16	NC		Not connected, empty pin
17	V12O_RTC	Power Output	1.2V LDO output for RTC & backup memory. Normally unused.
18	VBAT	Power Input	RTC & backup memory voltage input, 1.5V ~ 6.0V. Must be connected.
19	GND	Power	System ground
20	NC		Not connected, empty pin
21	GND_RF	Power	RF section system ground

22	GND_RF	Power	RF section system ground
23	NC		Not connected, empty pin
24	GND_RF	Power	RF section system ground
25	GND_RF	Power	RF section system ground
26	NC		Not connected, empty pin
27	GND_RF	Power	RF section system ground
28	GND_RF	Power	RF section system ground
29	GND_RF	Power	RF section system ground
30	NC		Not connected, empty pin
31	GND_RF	Power	RF section system ground
32	RFIN	Input	GPS signal input, connect to GPS antenna.
33	GND_RF	Power	RF section system ground
34	NC		Not connected, empty pin
35	NC		Not connected, empty pin
36	REG_ENA	Input	Tie to pin-2 VCC33I
37	BAUDSELO	Input	Hardware baud rate selection. See BaudSel1 3.3V LVTTTL
38	MOSI	Output	SPI data output, for data logging with external serial flash. 3.3V LVTTTL
39	MISO	Input	SPI data input, for data logging with external serial flash. 3.3V LVTTTL
40	P1PPS	Output	1 pulse per second output. Active after position fix; goes HIGH for about 4msec. 3.3V LVTTTL
41	SPI_CLK	Output	SPI clock, for data logging with external serial flash. 3.3V LVTTTL
42	RXD0	Input	Received input of the asynchronous UART port. Used to input binary command to the GPS receiver. 3.3V LVTTTL
43	SPI_CSN	Output	SPI chip select, for data logging with external serial flash. 3.3V LVTTTL
44	TXD0	Output	Transmit output of the asynchronous UART port. Used to output standard NMEA-0183 sentence or response to input binary command. 3.3V LVTTTL
45	NC		Not connected, empty pin
46	NC		Not connected, empty pin
47	NC		Not connected, empty pin
48	NC		Not connected, empty pin
49	GND		System ground
50	NC		Not connected, empty pin
51	NC		Not connected, empty pin
52	NC		Not connected, empty pin
53	NC		Not connected, empty pin
54	NC		Not connected, empty pin
55	NC		Not connected, empty pin
56	NC / V12		NC pin for Venus638LPx-L 1.2V supply input pin for Venus638LPx-D
57	NC		Not connected, empty pin
58	VCC33I	Power Input	Main voltage supply input, 2.8V ~ 3.6V
59	NC		Not connected, empty pin
60	GND	Power	System ground
61	GND_RF	Power	RF section system ground
62	GND_RF	Power	RF section system ground
63	NC		Not connected, empty pin
64	GND	Power	System ground
65	GND_RF	Power	RF section system ground
66	NC		
67	NC		
68	NC		
69	GND_RF	Power	RF section system ground

When using Venus638LPx-L to replace Venus634LPx, pin-45 ~ pin-69 can all be left unconnected.  
When using Venus638LPx-D, 1.2V need to be supplied at pin-56  
The NC pins are to be left unconnected.

# VENUS638FLPx PIN-OUT DIAGRAM

## Venus638FLPx-L / Venus638FLPx-D Top View

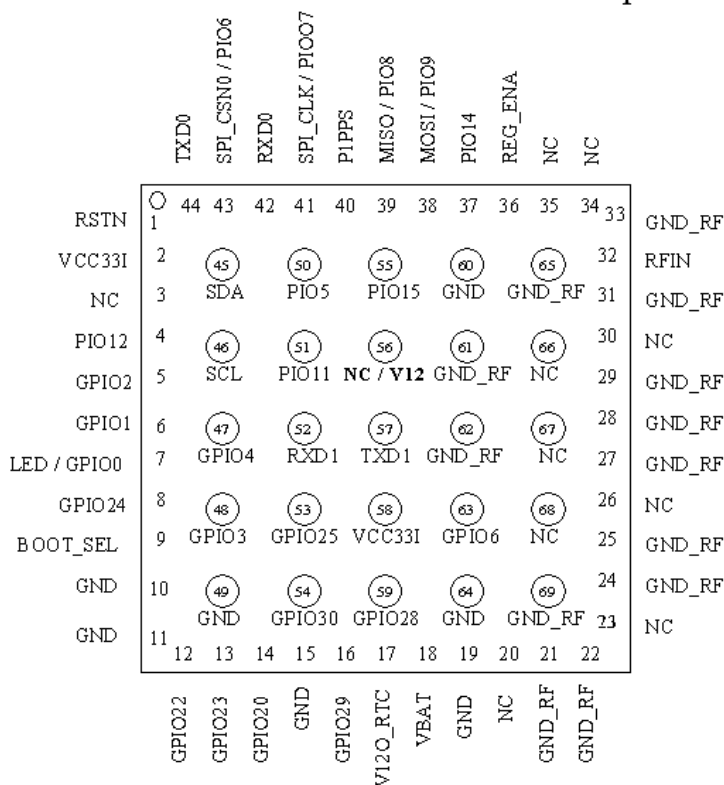

Figure-2b Venus638FLPx Pin-Out Diagram

## VENUS638FLPx PIN DEFINITION

Pin Number	Signal Name	Type	Description
1	RSTN	Input	Active LOW reset input, 3.3V LVTTTL
2	VCC33I	Power Input	Main voltage supply input, 2.8V ~ 3.6V
3	NC		Not connected, empty pin
4	PIO12	Bidir	General purpose I/O pin, 3.3V LVTTTL
5	GPIO2	Bidir	General purpose I/O pin, 3.3V LVTTTL
6	GPIO1	Bidir	General purpose I/O pin, 3.3V LVTTTL
7	LED / GPIO0	Bidir	Navigation status indicator or General purpose I/O. 3.3V LVTTTL
8	GPIO24	Bidir	General purpose I/O pin. 3.3V LVTTTL Also serves as Search Engine Mode Selection upon power-up 1: low power acquisition mode 0: enhanced acquisition mode
9	BOOT_SEL	Bidir	Boot mode selection. Pull-high or pull-low using 10K resistor. Must not connect to VCC or GND directly. 1: execute from internal ROM 0: execute from internal Flash memory
10	GND	Power	System ground
11	GND	Power	System ground
12	GPIO22	Bidir	General purpose I/O pin, 3.3V LVTTTL
13	GPIO23	Bidir	General purpose I/O pin, 3.3V LVTTTL
14	GPIO20	Bidir	General purpose I/O pin, 3.3V LVTTTL
15	GND	Power	System ground
16	GPIO29	Bidir	General purpose I/O pin, 3.3V LVTTTL
17	V12O_RTC	Power Output	1.2V LDO output for RTC & backup memory. Normally unused.
18	VBAT	Power Input	RTC & backup memory voltage input, 1.5V ~ 6.0V Must be connected.

19	GND	Power	System ground
20	NC		Not connected, empty pin
21	GND_RF	Power	RF section system ground
22	GND_RF	Power	RF section system ground
23	NC		Not connected, empty pin
24	GND_RF	Power	RF section system ground
25	GND_RF	Power	RF section system ground
26	NC		Not connected, empty pin
27	GND_RF	Power	RF section system ground
28	GND_RF	Power	RF section system ground
29	GND_RF	Power	RF section system ground
30	NC		Not connected, empty pin
31	GND_RF	Power	RF section system ground
32	RFIN	Input	GPS signal input, connect to GPS antenna.
33	GND_RF	Power	RF section system ground
34	NC		Not connected, empty pin
35	NC		Not connected, empty pin
36	REG_ENA	Input	Connect to pin-2 VCC33I
37	PIO14	Bidir	General purpose I/O pin, 3.3V LVTTTL
38	MOSI / PIO9	Bidir	SPI data output or general purpose I/O pin, 3.3V LVTTTL
39	MISO / PIO8	Bidir	SPI data input or general purpose I/O pin, 3.3V LVTTTL
40	P1PPS	Output	1 pulse per second output. Active after position fix; goes HIGH for about 4msec, 3.3V LVTTTL
41	SPI_CLK / PIO07	Output	SPI clock or general purpose output pin, 3.3V LVTTTL
42	RXD0	Input	Received input of the asynchronous UART port. Used to input binary command to the GPS receiver. 3.3V LVTTTL
43	SPI_CSN / PIO6	Bidir	SPI chip select output or general purpose I/O pin, 3.3V LVTTTL
44	TXD0	Output	Transmit output of the asynchronous UART port. Used to output standard NMEA-0183 sentence or response to input binary command. 3.3V LVTTTL
45	SDA	Bidir	I2C data, 3.3V I/O
46	SCL	Bidir	I2C clock, 3.3V I/O
47	GPIO4	Bidir	General purpose I/O pin, 3.3V LVTTTL
48	GPIO3	Bidir	General purpose I/O pin, 3.3V LVTTTL
49	GND		System ground
50	PIO5	Output	General purpose output pin, 3.3V LVTTTL
51	PIO11	Bidir	General purpose I/O pin, 3.3V LVTTTL
52	RXD1	Input	Received input of the asynchronous UART port. 3.3V LVTTTL
53	GPIO25	Bidir	General purpose I/O pin, 3.3V LVTTTL
54	GPIO30	Bidir	General purpose I/O pin, 3.3V LVTTTL
55	PIO15	Bidir	General purpose I/O pin, 3.3V LVTTTL
56	NC / V12		NC pin for Venus638FLPx-L 1.2V supply input pin for Venus638FLPx-D
57	TXD1	Output	Transmit output of the asynchronous UART port. 3.3V LVTTTL
58	VCC33I	Power Input	Main voltage supply input, 2.8V ~ 3.6V
59	GPIO28	Bidir	General purpose I/O pin, 3.3V LVTTTL
60	GND	Power	System ground
61	GND_RF	Power	RF section system ground
62	GND_RF	Power	RF section system ground
63	GPIO6	Bidir	General purpose I/O pin, 3.3V LVTTTL
64	GND	Power	System ground
65	GND_RF	Power	RF section system ground
66	NC		
67	NC		
68	NC		
69	GND_RF	Power	RF section system ground

When using Venus638FLPx-L to replace Venus634FLPx, pin-45 ~ pin-69 can all be left unconnected.  
When using Venus638FLPx-D, 1.2V need to be supplied at pin-56  
The NC pins are to be left unconnected.



## DC CHARACTERISTICS OF DIGITAL INTERFACE

Below is when VCC3I is at nominally 3.3V

Parameter	Min.	Typ.	Max.	Units
Input Low Voltage			0.8	Volt
Input High Voltage	2.0			Volt
Output Low Voltage, $I_{ol} = 2 \sim 16\text{mA}$			0.4	Volt
Output High Voltage, $I_{oh} = 2 \sim 16\text{mA}$	2.9			Volt

# MECHANICAL DIMENSION

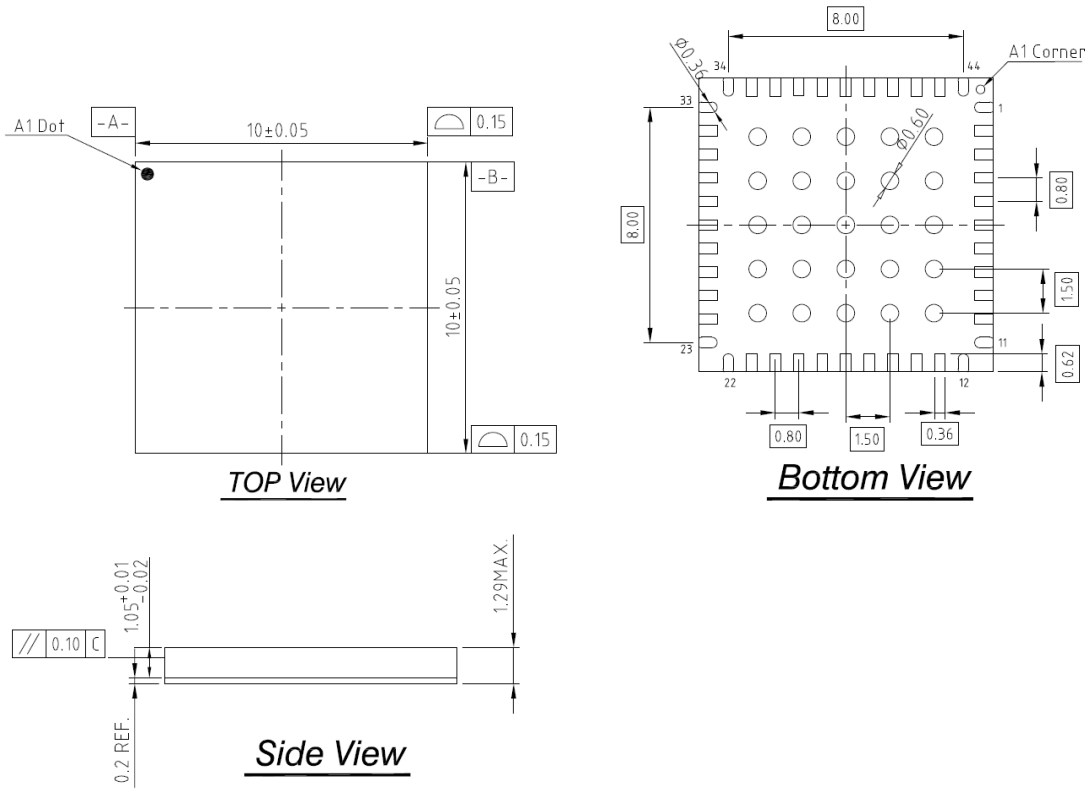

# RECOMMENDED PCB FOOTPRINT

Package size = 10 mm x 10mm x 1.3 mm  
 Package Pad = 15 x 21 mil  
 Package Pitch= 0.8 mm

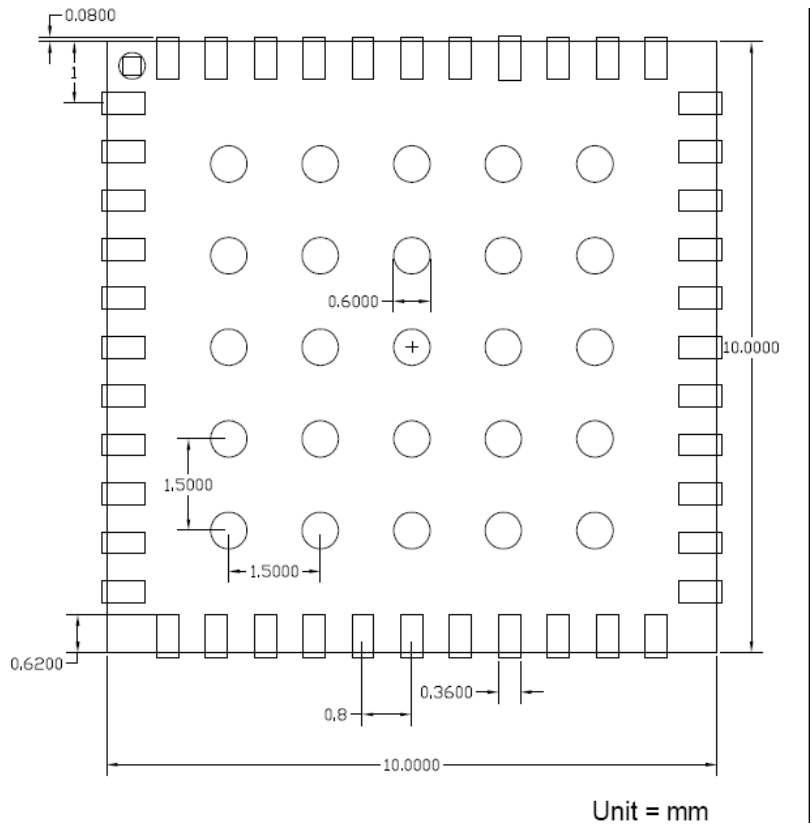
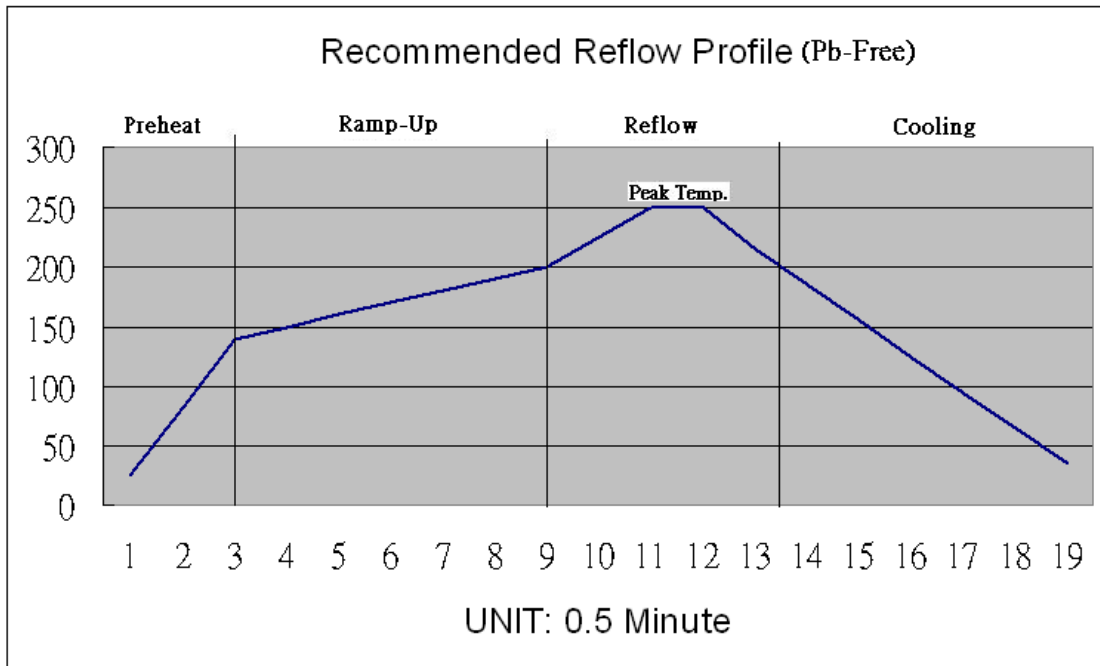

Figure-3 Recommended PCB Footprint.

# RECOMMENDED REFLOW PROFILE



Temperature (°C)	25	82.5	140	150	160	170	180	190	200	225	250	250	215	185	155	125	95	65	35
Time(minute)	0	0.5	1	1.5	2	2.5	3	3.5	4	4.5	5	5.5	6	6.5	7	7.5	8	8.5	9

Profile Description	SnPb Eutectic Process	Lead Free Process
<b>Preheat</b>		
Maximum Temperature	100+/-10 °C	140+/-10 °C
Time(Δ T)	40~60s	50~70s
<b>Ramp-Up</b>		
Ramp-Up Rate	1 °C/s Max.	1 °C/s Max.
Time(Δ T)	120~150s	160~200s
<b>Reflow</b>		
Maximum Temperature	Peak Temp.	Peak Temp.
Minimum Temperature	180+/-5°C	200+/-10°C
Peak Temperature	220+/-2°C	250+/-2°C
Time(Δ T) during Peak Temp.+/-2°C	10~30s	20~40s
Reflow Time(Δ T)	120~150s	120~150s
<b>Cooling</b>		
Cooling Rate	1.5 °C/s Max	1.5 °C/s Max
Time(Δ T)	60~120s	150~180s

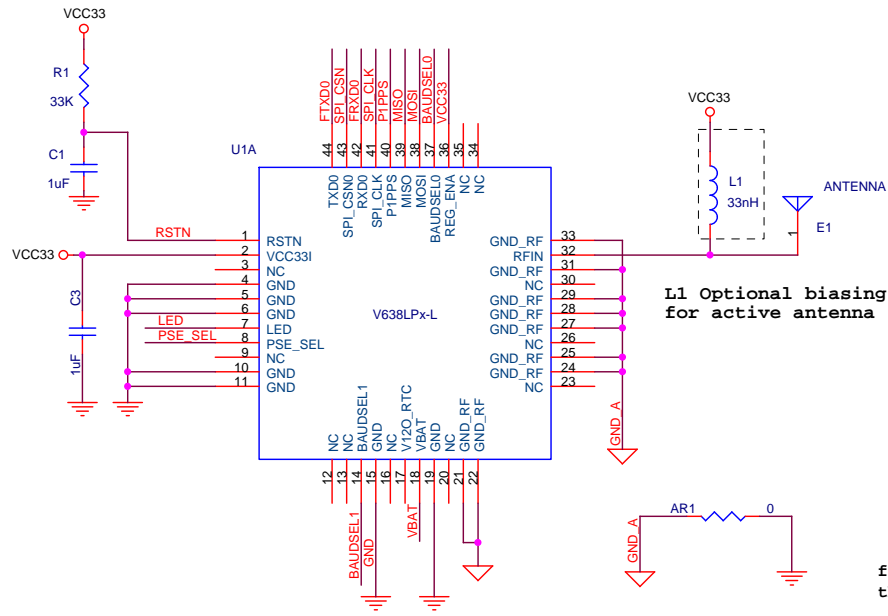

L1 Optional biasing for active antenna

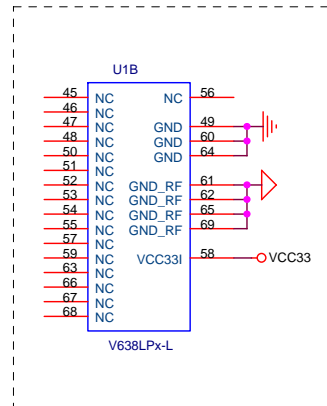

for Venus634LPx replacement application, these pins can be left unconnected

**BAUDSEL[1:0]:**  
 0 0:9600  
 0 1:4800  
 1 0:38400  
 1 1:115200

**PSE\_SEL:**  
 0: Enhanced acquisition  
 1: Low power acquisition

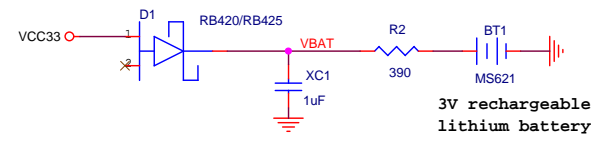

3V rechargeable lithium battery

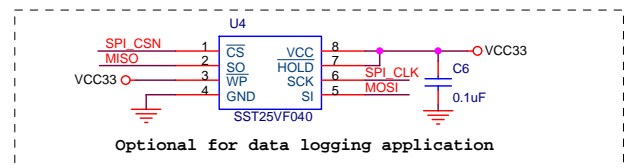

Optional for data logging application

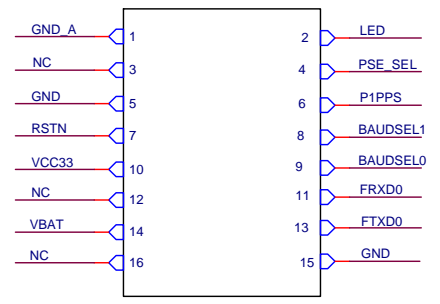

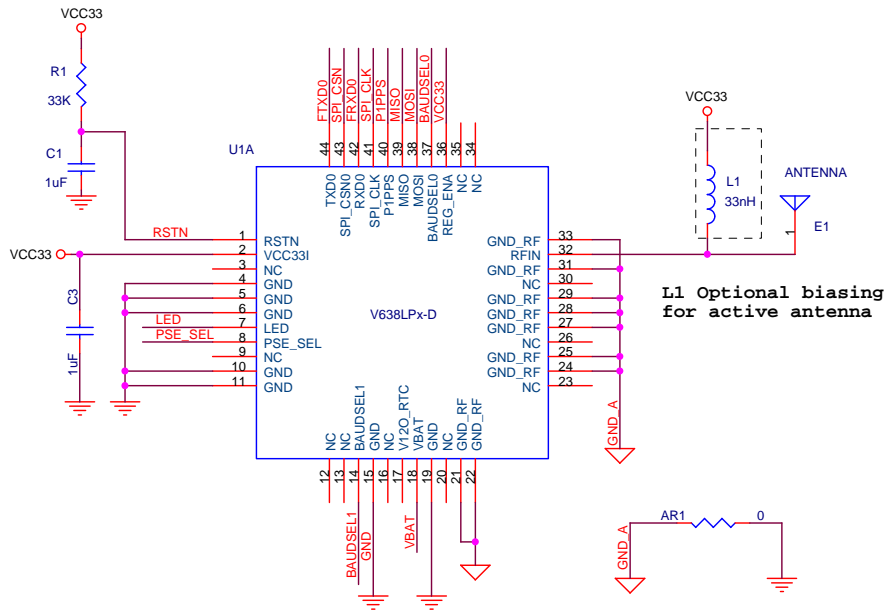

**BAUDSEL[1:0]:**  
 0 0:9600  
 0 1:4800  
 1 0:38400  
 1 1:115200

**PSE\_SEL:**  
 0: Enhanced acquisition  
 1: Low power acquisition

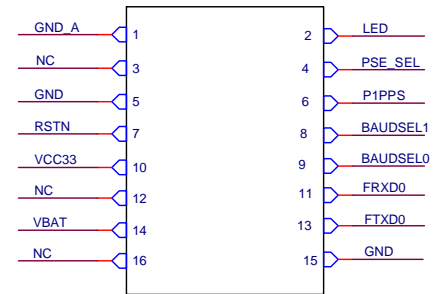
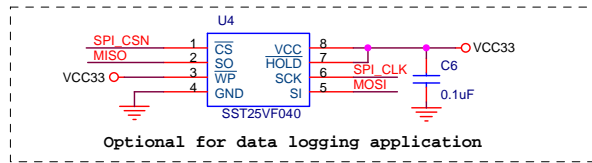
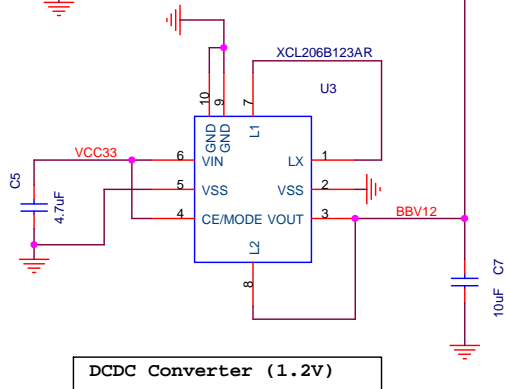
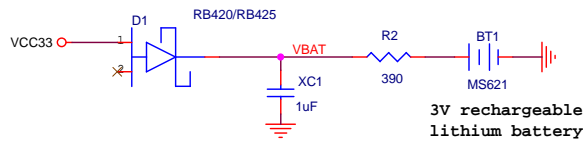

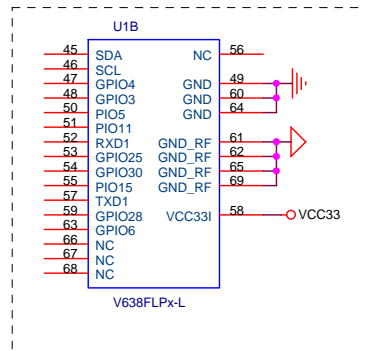
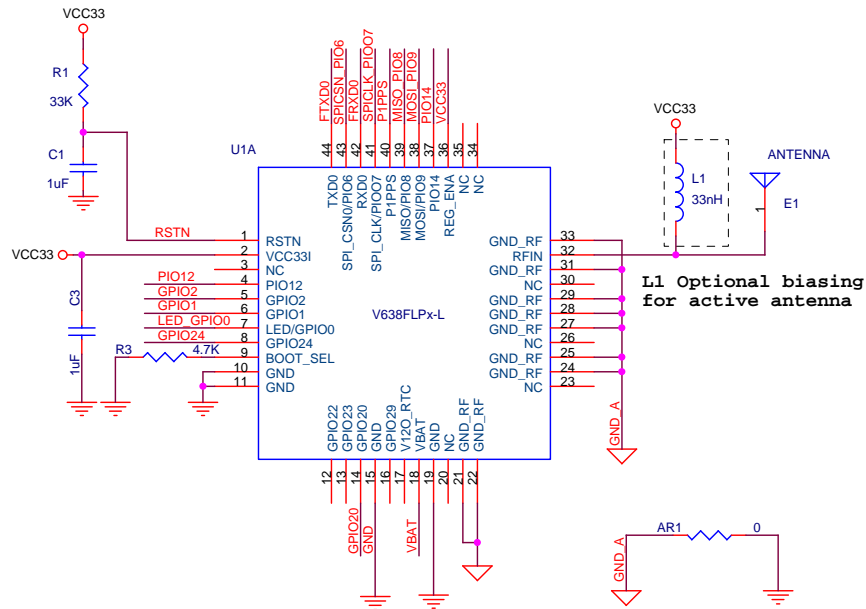

for Venus634FLPx replacement application, these pins can be left unconnected

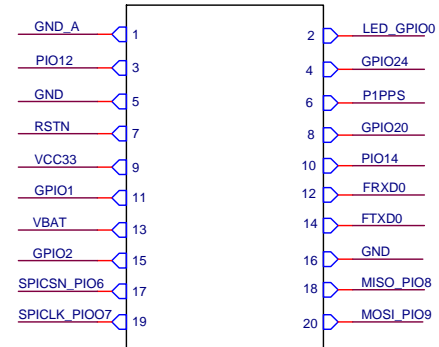
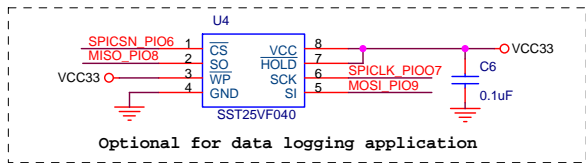
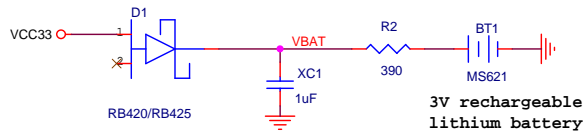

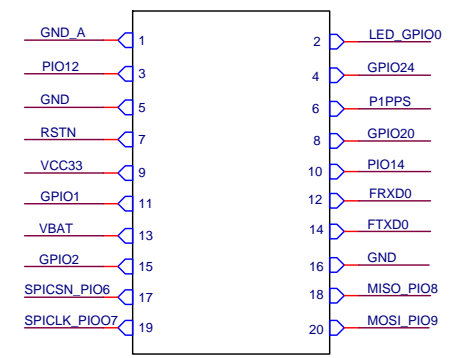
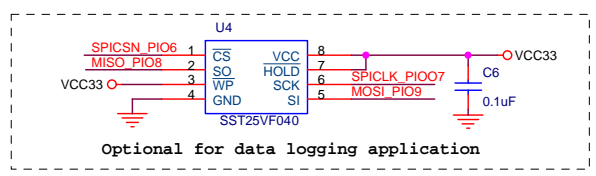
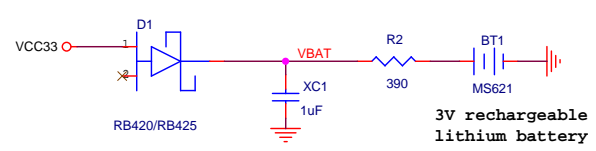
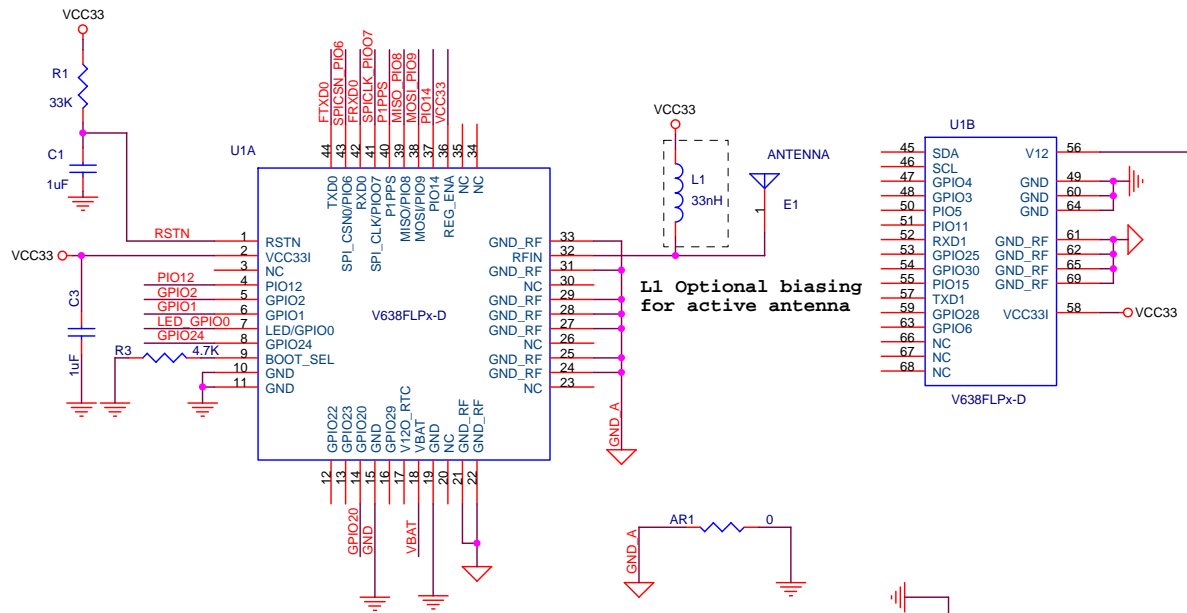

<b>Skytraq Technology, Inc.</b>		
Title Venus 638FLPx-D Application Circuit		
Size B	Document Number V638FLPx-D_AP001	Rev 1.0
Date:	Friday, February 26, 2010	Sheet 1 of 1

## APPLICATION CIRCUIT INTERFACE SIGNALS

GND_A:	RF ground
LED:	Signal to indicate GPS position status, 3.3V LVTTTL. Active low for no-fix, toggle every second after position fix.
PSE_SEL:	Search engine mode selection, sampled only at end of power-on reset cycle 1: Low power acquisition mode 0: Enhanced acquisition mode
GND:	Digital ground
P1PPS:	1 pulse per second time-mark (3.3V LVTTTL)
RSTN:	Active low reset input
VCC33:	3.3V power input
FRXD0:	UART input (3.3V LVTTTL)
FTXD0:	UART output (3.3V LVTTTL)
VBAT:	Battery-backed RTC and SRAM supply input, 1.5V ~ 6V, must not be unconnected.



## APPLICATION INFORMATION

1. For fast-rising power supply, a simple series R/C reset delay to pin-1, RSTN, as indicated in the application circuit is suitable. For system having slow-rising power supply, a reset IC providing 2~5ms reset duration may be necessary.
2. The RF input of Venus638 is already matched to 50-ohm. Passive antenna matched to 50-ohm can be directly applied.
3. For using Venus638 with active antenna, one with gain in range of 10~30dB and noise figure < 2dB can be used. Power to the active antenna needs to be applied externally.
4. Pin-18 VBAT supplies backup power to the real-time clock and backup SRAM for fast startup. For portable applications where there is battery with voltage in range of 1.5V ~ 6.0V as the main source, the VBAT pin can be directly connected to it. If VBAT is connected to main power as pin-2, no supply voltage as Venus638 is powered off, then it'll cold start every time and GPS performance will not be optimal.
5. Like BGA device, the Venus638 is moisture sensitive. It needs to be handled with care to void damage from moisture absorption and SMT re-flow. The device should be baked for 24 hours at 125-degC before mounting for SMT re-flow if it has been removed from the protective seal for more than 48<sup>\*1</sup> hours.
6. The supported SPI Flash memory verified for data logging application are:

Manufacturer	Device ID	Size
EON	EN25F040	4Mbit
EON	EN25F080	8Mbit
MXIC	MX25L400	4Mbit
MXIC	MX25L800	8Mbit
MXIC	MX25L1605	16Mbit
MXIC	MX25L3205	32Mbit
MXIC	MX25L6405	64Mbit
WINBOND	W25X40	4Mbit
WINBOND	W25X80	8Mbit
WINBOND	W25X16	16Mbit
WINBOND	W25X32	32Mbit
WINBOND	W25X64	64Mbit
SST	SST25LF040	4Mbit
SST	SST25LF080	8Mbit
SST	SST25VF016	16Mbit
SST	SST 25VF032	32Mbit

7. Adding a 10Kohm pull-down resistor to pin-9 of ROM type Venus638LPx-L (Venus638LPx-D) application circuitry allows Flash type Venus638FLPx-L (Venus638FLPx-D) to be used in its place later if needed.

\*1: Actual will be longer, moisture sensitivity level still undergoing verification.

## SLEEP MODE

For application requiring sleep mode, it can be implemented using regulator with enable control as below figure shows. To put Venus638 to sleep, the power to Venus638 is cut off by disabling the regulator via host processor GPIO pin. In sleep mode, VBAT consume less than 10uA. Fast start up operation is provided by keeping supply voltage to VBAT constant, retaining the internal data and keep RTC running while Venus638 is put to sleep or when supply 3.3V power is removed.

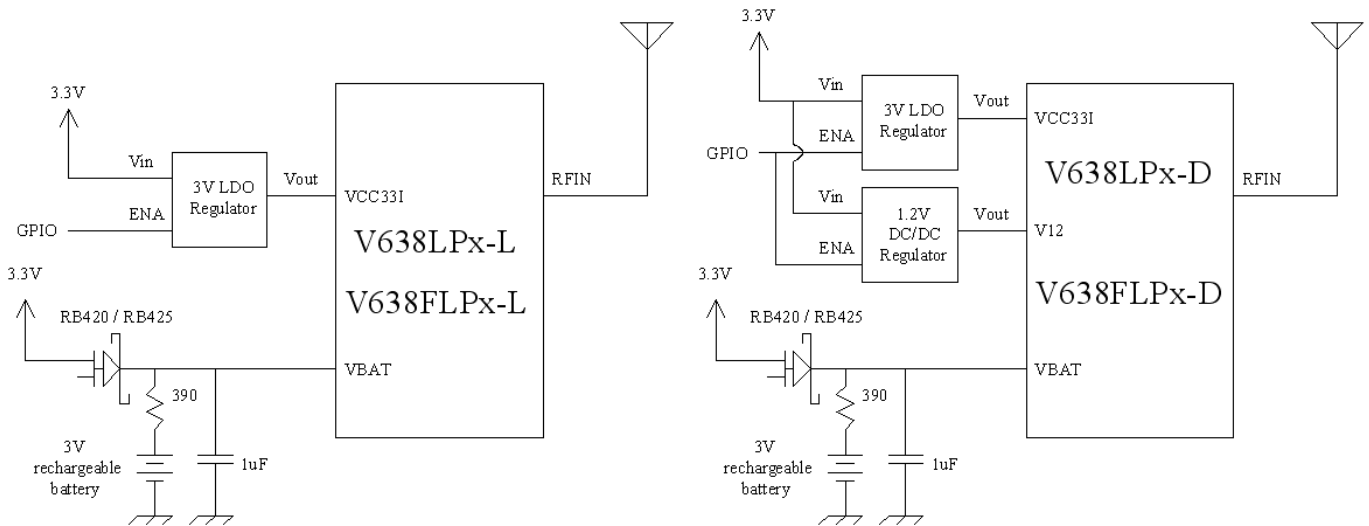

For applications needing sleep mode but cannot have extra cost of adding a rechargeable backup supply battery, it can be implemented as below figure shows. It will provide fast start up when Venus638 is put to sleep and awakened, but will cold start every time when the 3.3V supply voltage is removed and re-applied again.

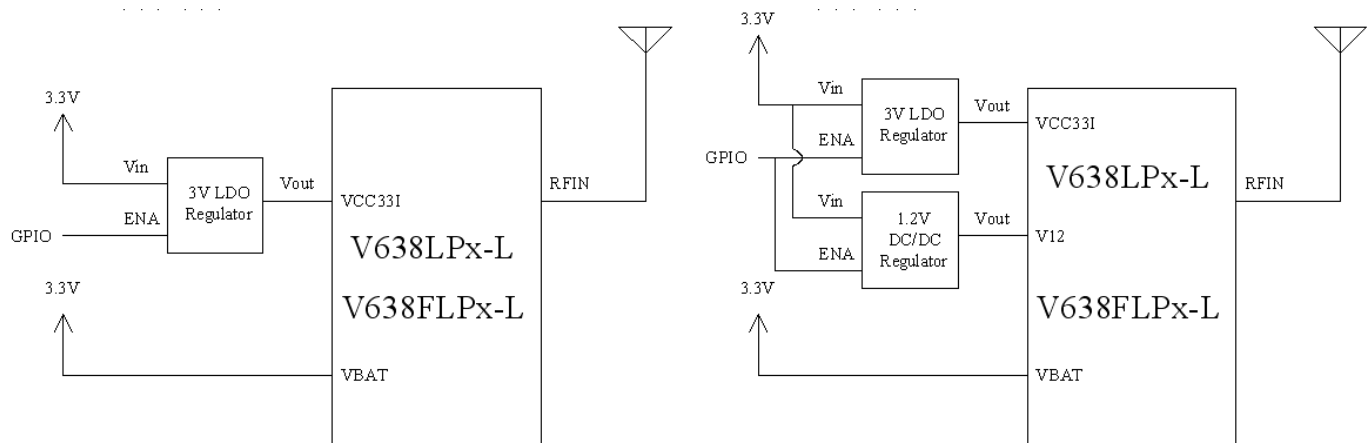

When using sleep mode, add 10K series resistor on pin-42 RXD0 and pin-44 TXD0.

## PACKAGE

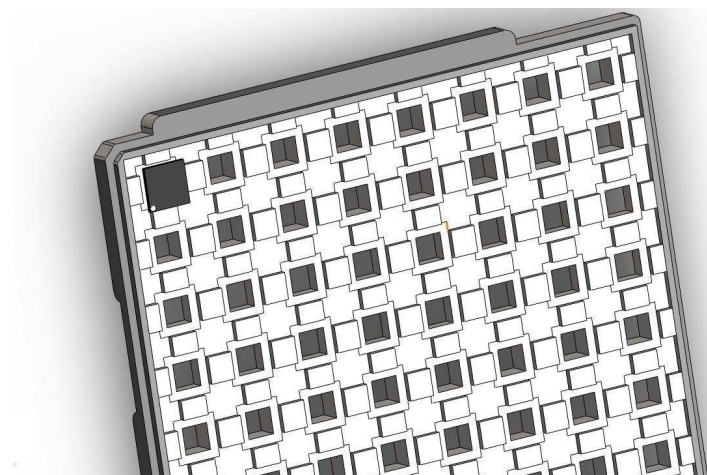
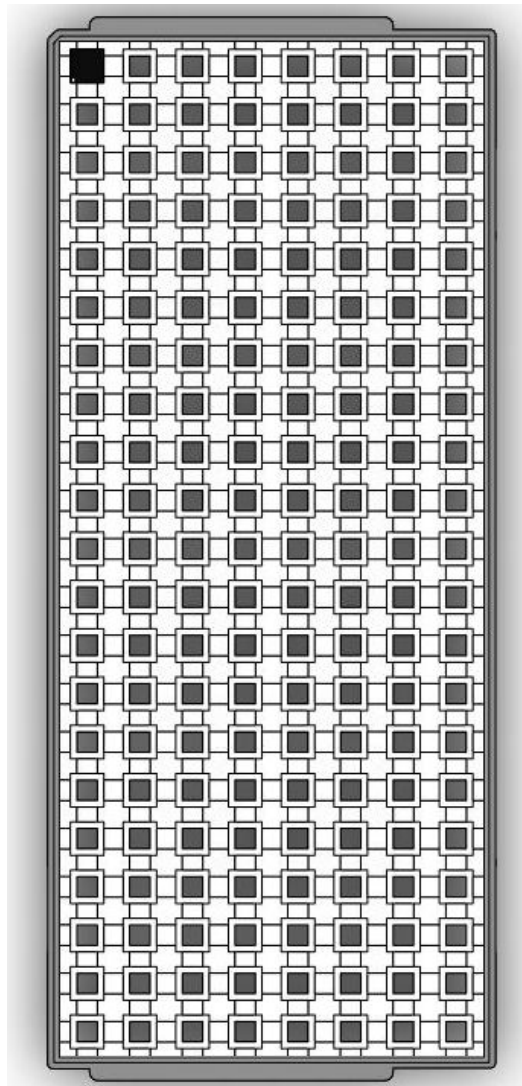

## NMEA MESSAGES

The full descriptions of supported NMEA messages are provided at the following paragraphs.

### **GGA - Global Positioning System Fix Data**

Time, position and fix related data for a GPS receiver.

Structure:

```
$GPGGA,hhmmss.sss,ddmm.mmmm,a,dddmm.mmmm,a,x,xx,x.x,x.x,M,,,,,xxxx*hh<CR><LF>
```

1        2        3        4        5 6 7 8 9        10 11

Example:

```
$GPGGA,111636.932,2447.0949,N,12100.5223,E,1,11,0.8,118.2,M,,,,,0000*02<CR><LF>
```

Field	Name	Example	Description
1	UTC Time	111636.932	UTC of position in hhmmss.sss format, (000000.000 ~ 235959.999)
2	Latitude	2447.0949	Latitude in ddmm.mmmm format Leading zeros transmitted
3	N/S Indicator	N	Latitude hemisphere indicator, 'N' = North, 'S' = South
4	Longitude	12100.5223	Longitude in dddmm.mmmm format Leading zeros transmitted
5	E/W Indicator	E	Longitude hemisphere indicator, 'E' = East, 'W' = West
6	GPS quality indicator	1	GPS quality indicator 0: position fix unavailable 1: valid position fix, SPS mode 2: valid position fix, differential GPS mode 3: GPS PPS Mode, fix valid 4: Real Time Kinematic. System used in RTK mode with fixed integers 5: Float RTK. Satellite system used in RTK mode. Floating integers 6: Estimated (dead reckoning) Mode 7: Manual Input Mode 8: Simulator Mode
7	Satellites Used	11	Number of satellites in use, (00 ~ 12)
8	HDOP	0.8	Horizontal dilution of precision, (00.0 ~ 99.9)
9	Altitude	108.2	mean sea level (geoid), (-9999.9 ~ 17999.9)
10	DGPS Station ID	0000	Differential reference station ID, 0000 ~ 1023 NULL when DGPS not used
11	Checksum	02	

## GLL – Latitude/Longitude

Latitude and longitude of current position, time, and status.

Structure:

```
$GPGLL,ddmm.mmmm,a,dddmm.mmmm,a,hhmmss.sss,A,a*hh<CR><LF>
```

1      2      3      4      5    6 7 8

Example:

```
$GPGLL,2447.0944,N,12100.5213,E,112609.932,A,A*57<CR><LF>
```

Field	Name	Example	Description
1	Latitude	2447.0944	Latitude in ddmm.mmmm format Leading zeros transmitted
2	N/S Indicator	N	Latitude hemisphere indicator 'N' = North 'S' = South
3	Longitude	12100.5213	Longitude in dddmm.mmmm format Leading zeros transmitted
4	E/W Indicator	E	Longitude hemisphere indicator 'E' = East 'W' = West
5	UTC Time	112609.932	UTC time in hhmmss.sss format (000000.000 ~ 235959.999)
6	Status	A	Status, 'A' = Data valid, 'V' = Data not valid
7	Mode Indicator	A	Mode indicator 'N' = Data not valid 'A' = Autonomous mode 'D' = Differential mode 'E' = Estimated (dead reckoning) mode 'M' = Manual input mode 'S' = Simulator mode
8	Checksum	57	

**GSA – GNSS DOP and Active Satellites**

GPS receiver operating mode, satellites used in the navigation solution reported by the GGA or GNS sentence and DOP values.

Structure:

```
$GPGSA,A,x,xx,xx,xx,xx,xx,xx,xx,xx,xx,xx,xx,xx,x.x,x.x,x.x*hh<CR><LF>
  1 2 3 3 3 3 3 3 3 3 3 3 3 4 5 6 7
```

Example:

```
$GPGSA,A,3,05,12,21,22,30,09,18,06,14,01,31,,1.2,0.8,0.9*36<CR><LF>
```

Field	Name	Example	Description
1	Mode	A	Mode 'M' = Manual, forced to operate in 2D or 3D mode 'A' = Automatic, allowed to automatically switch 2D/3D
2	Mode	3	Fix type 1 = Fix not available 2 = 2D 3 = 3D
3	Satellite used 1~12	05,12,21,22,30,09,18,06,14,01,31,,	Satellite ID number, 01 to 32, of satellite used in solution, up to 12 transmitted
4	PDOP	1.2	Position dilution of precision (00.0 to 99.9)
5	HDOP	0.8	Horizontal dilution of precision (00.0 to 99.9)
6	VDOP	0.9	Vertical dilution of precision (00.0 to 99.9)
7	Checksum	36	

**GSV – GNSS Satellites in View**

Number of satellites (SV) in view, satellite ID numbers, elevation, azimuth, and SNR value. Four satellites maximum per transmission.

Structure:

```
$GPGSV,x,x,xx,xx,xx,xxx,xx,...,xx,xx,xxx,xx *hh<CR><LF>
  1 2 3 4 5 6 7 4 5 6 7 8
```

Example:

```
$GPGSV,3,1,12,05,54,069,45,12,44,061,44,21,07,184,46,22,78,289,47*72<CR><LF>
$GPGSV,3,2,12,30,65,118,45,09,12,047,37,18,62,157,47,06,08,144,45*7C<CR><LF>
$GPGSV,3,3,12,14,39,330,42,01,06,299,38,31,30,256,44,32,36,320,47*7B<CR><LF>
```

Field	Name	Example	Description
1	Number of message	3	Total number of GSV messages to be transmitted (1-3)
2	Sequence number	1	Sequence number of current GSV message
3	Satellites in view	12	Total number of satellites in view (00 ~ 12)
4	Satellite ID	05	Satellite ID number, GPS: 01 ~ 32, SBAS: 33 ~ 64 (33 = PRN120)
5	Elevation	54	Satellite elevation in degrees, (00 ~ 90)
6	Azimuth	069	Satellite azimuth angle in degrees, (000 ~ 359 )
7	SNR	45	C/No in dB (00 ~ 99) Null when not tracking
8	Checksum	72	

## RMC – Recommended Minimum Specific GNSS Data

Time, date, position, course and speed data provided by a GNSS navigation receiver.

Structure:

```
$GPRMC,hhmmss.sss,A,dddmm.mmmm,a,dddmm.mmmm,a,x.x,x.x,ddmmy,,,a*hh<CR><LF>
```

1 2 3 4 5 6 7 8 9 10 11

Example:

```
$GPRMC,111636.932,A,2447.0949,N,12100.5223,E,000.0,000.0,030407,,,A*61<CR><LF>
```

Field	Name	Example	Description
1	UTC time	0111636.932	UTC time in hhmmss.sss format (000000.00 ~ 235959.999)
2	Status	A	Status 'V' = Navigation receiver warning 'A' = Data Valid
3	Latitude	2447.0949	Latitude in dddmm.mmmm format Leading zeros transmitted
4	N/S indicator	N	Latitude hemisphere indicator 'N' = North 'S' = South
5	Longitude	12100.5223	Longitude in dddmm.mmmm format Leading zeros transmitted
6	E/W Indicator	E	Longitude hemisphere indicator 'E' = East 'W' = West
7	Speed over ground	000.0	Speed over ground in knots (000.0 ~ 999.9)
8	Course over ground	000.0	Course over ground in degrees (000.0 ~ 359.9)
9	UTC Date	030407	UTC date of position fix, ddmmyy format
10	Mode indicator	A	Mode indicator 'N' = Data not valid 'A' = Autonomous mode 'D' = Differential mode 'E' = Estimated (dead reckoning) mode 'M' = Manual input mode 'S' = Simulator mode
11	checksum	61	



### **VTG – Course Over Ground and Ground Speed**

The Actual course and speed relative to the ground.

Structure:

GPVTG,x.x,T,,M,x.x,N,x.x,K,a\*hh<CR><LF>

1 2 3 4 5

Example:

\$GPVTG, 000.0,T,,M,000.0,N,0000.0,K,A\*3D<CR><LF>

Field	Name	Example	Description
1	Course	000.0	True course over ground in degrees (000.0 ~ 359.9)
2	Speed	000.0	Speed over ground in knots (000.0 ~ 999.9)
3	Speed	0000.0	Speed over ground in kilometers per hour (0000.0 ~ 1800.0)
4	Mode	A	Mode indicator 'N' = not valid 'A' = Autonomous mode 'D' = Differential mode 'E' = Estimated (dead reckoning) mode 'M' = Manual input mode 'S' = Simulator mode
5	Checksum	3D	

## ORDERING INFORMATION

Part Number	Description
Venus638LPx-L	ROM version GPS receiver module (internal 1.2V LDO version)
Venus638LPx-D	ROM version GPS receiver module (external 1.2V version)
Venus638FLPx-L	Flash version GPS receiver module (internal 1.2V LDO version)
Venus638FLPx-D	Flash version GPS receiver module (external 1.2V version)

SkyTraq Technology, Inc.  
4F, No.26, Minsiang Street, Hsinchu, Taiwan, 300  
Phone: +886 3 5678650  
Fax: +886 3 5678680  
Email: info@skytraq.com.tw

© 2008 SkyTraq Technology Inc. All rights reserved.

Not to be reproduced in whole or part for any purpose without written permission of SkyTraq Technology Inc ("SkyTraq"). Information provided by SkyTraq is believed to be accurate and reliable. These materials are provided by SkyTraq as a service to its customers and may be used for informational purposes only. SkyTraq assumes no responsibility for errors or omissions in these materials, nor for its use. SkyTraq reserves the right to change specification at any time without notice.

These materials are provided "as is" without warranty of any kind, either expressed or implied, relating to sale and/or use of SkyTraq products including liability or warranties relating to fitness for a particular purpose, consequential or incidental damages, merchantability, or infringement of any patent, copyright or other intellectual property right. SkyTraq further does not warrant the accuracy or completeness of the information, text, graphics or other items contained within these materials. SkyTraq shall not be liable for any special, indirect, incidental, or consequential damages, including without limitation, lost revenues or lost profits, which may result from the use of these materials.

SkyTraq products are not intended for use in medical, life-support devices, or applications involving potential risk of death, personal injury, or severe property damage in case of failure of the product.

## Change Log

Version 0.1, February 24, 2010

1. Initial release