



产品规格书

PRODUCT SPECIFICATION

客户名称Buyer Name	
客户料号Buyer Part No.	
客户承认签章 Buyers Approval & Signatures	

文件编号Spec No.	S-324317	版本	A/0
品名描述 Product Description	无刷直流振动马达 BLDC Vibration Motor		
型号Part No.	W0934AB007G		
送样日期Date			
设计Designed by	审核Checked by	批准Approved by	
陳满	陈满	陈满	
2019.3.19	2019.3.19	2019.3.19	

Jinlong Machinery & Electronics
www.jinlong-machinery.com
sales@jinlong-machinery.com



NO	ITEM	Page
1	Revision History	3
2	Application	4
3	Standard Operating Condition	4
4	Standard Measurement Condition	4
5	Judgment Environmental Condition	5
6	Test Tolerance	5
7	Electrical Characteristics	5
8	Mechanical Characteristics	6
9	Reliability Test	7~8
10	Caution	9
11	Specification Change	10
12	Drawing	11

Part Number		Company	JINLONG	Approval No.	S-324317
Specification	Φ9 x 3.4T	Name of applied Model	W0934AB007G	Enactment	2019.3.19
				Revision	

1. REVISION HISTORY

REV No.	Date	Description	Inspector	Designed	Approved

Part Number		Company	JINLONG	Approval No.	S-324317
Specification	Φ9 x 3.4T	Name of applied Model	W0934AB007G	Enactment	2019.3.19
				Revision	

2. Scope

This specification is applies to **W0934AB007G** vibration motors to be used for mobile telephone or IT devices.

3. Contents

No.	Item	Specification
3-1	Operating Voltage Range	DC 2.7V ~ 3.3V
3-2	Storage Temperature Range	(-)40 ~ (+)85°C
3-3	Operating Temperature Range	(-)30 ~ (+)70°C However, there is 45% decrease of rated load speed of the section 7-3 at -30°C compared to +25°C.
3-4	Operating Position	All Direction

4. Standard Test Condition

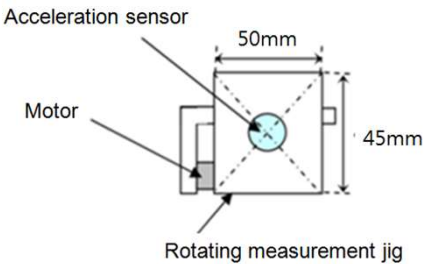
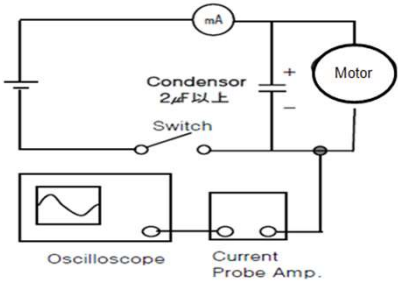
No.	Item	Specification
4-1	Temperature	20 ± 15% °C
4-2	Humidity	65% ± 20% RH
4-3	Measurement Voltage	DC3.0V
4-4	<div style="display: flex; justify-content: space-around; align-items: center;"> <div style="text-align: center;">  <p>Standard Measurement State</p> </div> <div style="text-align: center;">  <p>Inspection Circuit Diagram</p> </div> </div> <p>– Jig : 50 x 46 x 45mm [Material is POM] – Weight: 150g – The vibrator is Clamped firmly (0.5~1Kg pressure) on a test fixture</p>	

Part Number		Company	JINLONG	Approval No.	S-324317
Specification	Φ9 x 3.4T	Name of applied Model	W0934AB007G	Enactment	2019.3.19
				Revision	

5. Judgment Environmental Condition

NO	Item	Condition
5-1	Temperature	20 ± 15% °C
5-2	Humidity	65% ± 20%RH

6. Test Tolerance

Test set-ups and equipment shall be capable of maintaining following condition, unless otherwise specified.

NO	Item	Condition
6-1	Room Temperature & Humidity	20 ± 15% °C / 65 ± 20%RH
6-2	Test Chamber Temperature	Limits ± 3 °C
6-3	Voltage	Limits ± 0.15V

7. Electrical Characteristics

No	Item	Test Condition	Condition
7-1	Rated Voltage		DC 3.0V
7-2	Rotating Direction	CW [Lead Wire Red(+), Black(-) CW [Lead Wire Red to (+), Black to (-)]	CW
7-3	Rated Load Speed	It is based on the standard measurement condition of the section 4.	11,500 ± 2,500 rpm
7-4	Rated Load Current		80 mA max
7-5	Starting Current		175 mA max
7-6	Starting Voltage	Motor 4-1, 4-2, 4-4 On/Off . Motor On/Off test based on the standard measurement condition of the section 4-1, 4-2, and 4-4.	DC 2.5 V max
7-7	Insulation Voltage	Measured between terminal and case with DC 100V Megger.	10 MΩ min

Part Number		Company	JINLONG	Approval No.	S-324317
Specification	Φ9 x 3.4T	Name of applied Model	W0934AB007G	Enactment	2019.3.19
				Revision	

8. Mechanical Characteristics

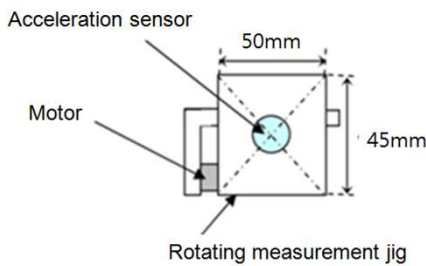
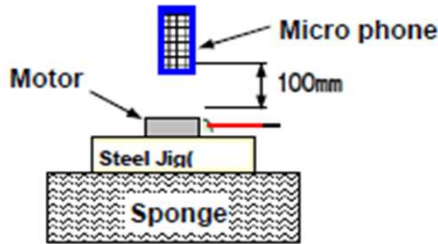
NO	Item	Specification	Condition
8-1	Vibration Force	<ul style="list-style-type: none"> - Vibration Force: 1.4Grms (AVG.) - 50 x 46 x 45mm [Material is POM] - Weight : 150g - The vibrator is Clamped firmly (0.5~1Kg pressure) on a test fixture, 	It is referred to the rated load speed of the section 7-3
8-2	Mechanical Noise	<ul style="list-style-type: none"> - Motor shall be fixed on Jig by adhesive tape - Jig Material 	50dB 50dB MAX 24dB
8-3	Weight		about 1.0g

Part Number		Company	JINLONG	Approval No.	S-324317
Specification	Φ9 x 3.4T	Name of applied Model	W0934AB007G	Enactment	2019.3.19
				Revision	

9. Reliability Test

NO	Item	Test Condition			Specification
9-1	Room Temperature & Humidity Life Test		Room Temp. & Humi. L/T	High Temp. & Humi. L/T	-
9-2	High Temperature & Humidity Life Test	Voltage	DC 3.0V	DC 3.0V	
		Temperature	20±15℃	40℃	
		Humidity	65±20% RH	90% RH	
		Life cycles	1,000,000 cycles	300,000 cycles	
		Duty Cycle	0.5 sec ON / 0.5 sec OFF	0.5 sec ON / 0.5 sec OFF Motor shall be fixed on Jig by adhesive tape. (Refer to the section 4-4)	
9-3	Composite Test	Conduct the continuous running for 10 hours as following Then storage at 60℃ 90% for 500hours			(Rated Load Speed: Initial value±20%, or within rated load speed)
9-4	Low Temperature Storage Performance	Exposed to -40℃ for 500 hours and then room temperature for 4 hours.			(Rated Load Current: Initial value ±30%)
9-5	High Temperature Storage Performance	-Exposed to +85℃, 60%RH for 500 hours and then room temperature for 4 hours.			
9-6	High Temperature and Humidity Storage Performance	- Exposed to +60℃, 90%RH for 500 hours and then room temperature for 4 hours.			

Part Number		Company	JINLONG	Approval No.	S-324317
Specification	Φ9 x 3.4T	Name of applied Model	W0934AB007G	Enactment	2019.3.19
				Revision	

9. Reliability Test

NO	Item	Test Condition	Specification
9-7	Thermal Shock Test	Total 200cycles at -40℃ and +85℃ for 30min each (1cycle=1 H) -Temperature Change Time < 5min -Motor shall be measured after exposure at room temperature for 4 hours.	-(Rated Load Speed: Initial value ±20%, or within rated load speed) (Rated Load Current: Initial value ±30%)
9-8	Drop Test	Dummy set (about 130g) motor shall be dropped onto concrete plate. 3times each side of 6 directions from a height of 150 cm, total 18 times.	
9-9	Vibration Test	Standard-packed motor is subjected to sine wave 10Hz~55Hz. X, Y, Z directions for 2 hours each., total 6 hours.	

Table 1. Evaluation items after reliability test

No.	Items	Specification
1-1	Rated current	Rated Load Current: Initial value ±30%
1-2	Rated speed	Rated Load Speed: Initial value ±30%, or within rated load speed
1-3	Acoustic noise	50dB(A) max.
1-4	Others	No deformation, crack, separation of parts.

※ A dummy jig for free-drop



Mass : 100gr ± 10%

Size : 110 X 65 X 16 mm

Material : POM

Thickness of the cushion tape : 1.0mm

(Compressive ratio : 50%)

The upper case is faced to the cushion tape

Part Number		Company	JINLONG	Approval No.	S-324317
Specification	Φ9 x 3.4T	Name of applied Model	W0934AB007G	Enactment	2019.3.19
				Revision	

10. Caution

NO	Item	Specification
10-1	Operating Range	- When using on the operating condition different from a standard, a problem can be generated to the performance and the life of a product.
10-2	Storage	- Avoid from placing motor for long term of six months under environmental condition of high temperature or extreme humidity, or motor may be deteriorated.
10-3	Motor Motor Handling	<p>To handle the motor, hold the case softly.</p> <p>-Motor: Do not bring a magnetized object or attracted object by the magnet of motor, or such object may deteriorate a performance of motor.</p> <p>Input short to the motor due to mis-operating, Drive IC of the motor inside can be damaged. To avoid this problem, please add capacitor of 2uF or more between the power lines in parallel with the motor.</p> <p>-Driver IC : Supplying voltage more than DC 4.5V can damage the driver IC</p>

Part Number		Company	JINLONG	Approval No.	S-324317
Specification	Φ9 x 3.4T	Name of applied Model	W0934AB007G	Enactment	2019.3.19
				Revision	

11. Specification Change

Even when there is any change to this specification, change application report which has the information of details

- of the change, lot of product, and etc shall be presented to customer before that change being carried out.
- And mutual discussion may be necessary before the change being carried out. Revision history shall be recorded on to the specification sheet when the change record and approval may be required.

Part Number		Company	JINLONG	Approval No.	S-324317
Specification	Φ9 x 3.4T	Name of applied Model	W0934AB007G	Enactment	2019.3.19
				Revision	

REV	NO.	CONTENTS	ENGINEER	APPROVER	DATE(yy/mm/dd)
△	1				

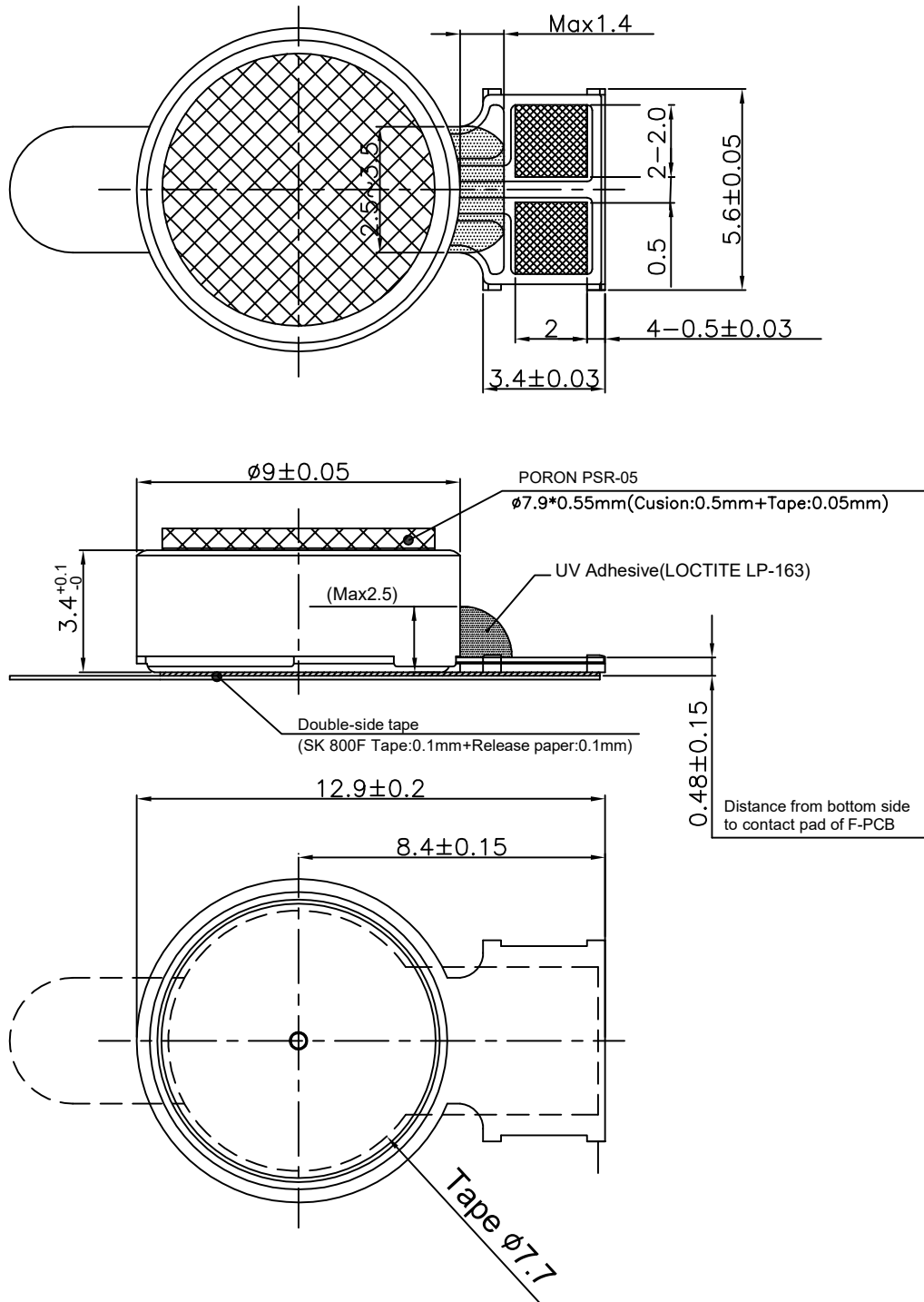

3		LEAD WIRE		1						
2		RUBBER		1						
1		Vibrator		1						
NO.	PART NO.	PART NAME	MATERIAL	QTY	FINISH	REMARK				
UNLESS OTHERWISE SPECIFIED, DIMENSIONS ARE IN MILLIMETERS, AND TOLERANCE ARE AS FOLLOWS:			UNIT mm	SIZE A4	SCALE 5/1	SHEET 1/1				
<table border="1"> <tr> <th colspan="2">GENERAL TOLERANCE(±)</th> </tr> <tr> <td>m/m</td> <td>0.2</td> </tr> </table>			GENERAL TOLERANCE(±)		m/m	0.2			MODEL W0934AB007G	
GENERAL TOLERANCE(±)										
m/m	0.2									
ANGULAR TOLERANCE : ±0.5° Jinlong Machinery & Electronics R & D CENTER			DESIGNED	DATE (YY/MM/DD) 2019.3.19	PART NAME BLDC VIBE MOTOR					
			CHECKED	DATE (YY/MM/DD)	DRAWING NO. S-324317					
			APPROVED	DATE (YY/MM/DD)						